

Specifications

Units: Imperial Metric

Maximum Spread (in)	3.90
Power Source	Hydraulic
Tip Clearance (in)	0
Usable on Flanges Specified to Accept the Following Bolt Sizes	M60 (2 3/8"), M64 (2 1/2"), M70 (2 3/4")

Dimensions

Units: Imperial Metric

Dimension A1, Minimum Axial Tool Space (for installation) (in)	24.4
Dimension A2, Minimum Axial Tool Space (installed) (in)	35.4
Dimension F, Minimum Flange Joint Thickness (in)	7.5
Dimension F, Maximum Flange Joint Thickness (in)	17.7
Dimension P1, Minimum Axial Plug Space (for installation) (in)	11.1
Dimension P2, Minimum Axial Plug Space (installed) (in)	11.1
Dimension R, Minimum Radial Space (in)	2.2
Dimension V, Minimum Valve/Spacer Thickness (in)	0
Case Dimensions (in)	35.0 x 22.4 x 6.5

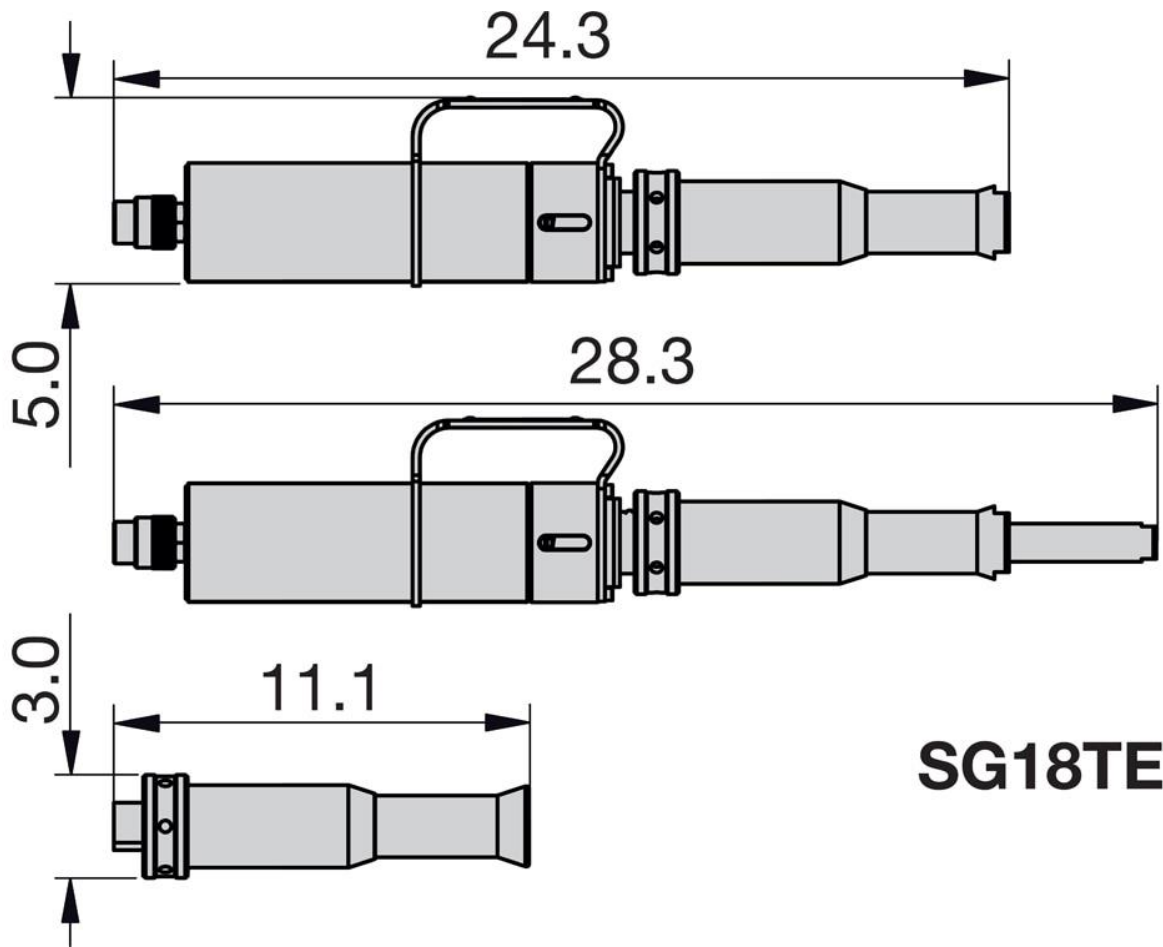

SG18TE

SPACIAL ENVELOPE

