

Specifications

Units:

Imperial

Metric

Maximum Operating Pressure (psi)	10,000
Maximum Spread (in)	4.72
Power Source	Hydraulic
Capacity (imperial tons)	28.1
Tip Clearance (in)	0
Usable on Flanges Specified to Accept the Following Bolt Sizes	M76 (3"), M80 (3 1/4"), M84 (3 3/8"), M90 (3 1/2"), M95 (3 3/4"), M100 (4")
Weight (lbs)	110.2

Dimensions

Units:

Imperial

Metric

Dimension A1, Minimum Axial Tool Space (for installation) (in)	29.5
Dimension A2, Minimum Axial Tool Space (installed) (in)	43.3
Dimension F, Minimum Flange Joint Thickness (in)	8.3
Dimension F, Maximum Flange Joint Thickness (in)	22.4
Dimension P1, Minimum Axial Plug Space (for installation) (in)	15.0
Dimension P2, Minimum Axial Plug Space (installed) (in)	15.0
Dimension R, Minimum Radial Space (in)	2.2
Dimension V, Minimum Valve/Spacer Thickness (in)	0
Case Dimensions (in)	35.0 x 22.4 x 6.5

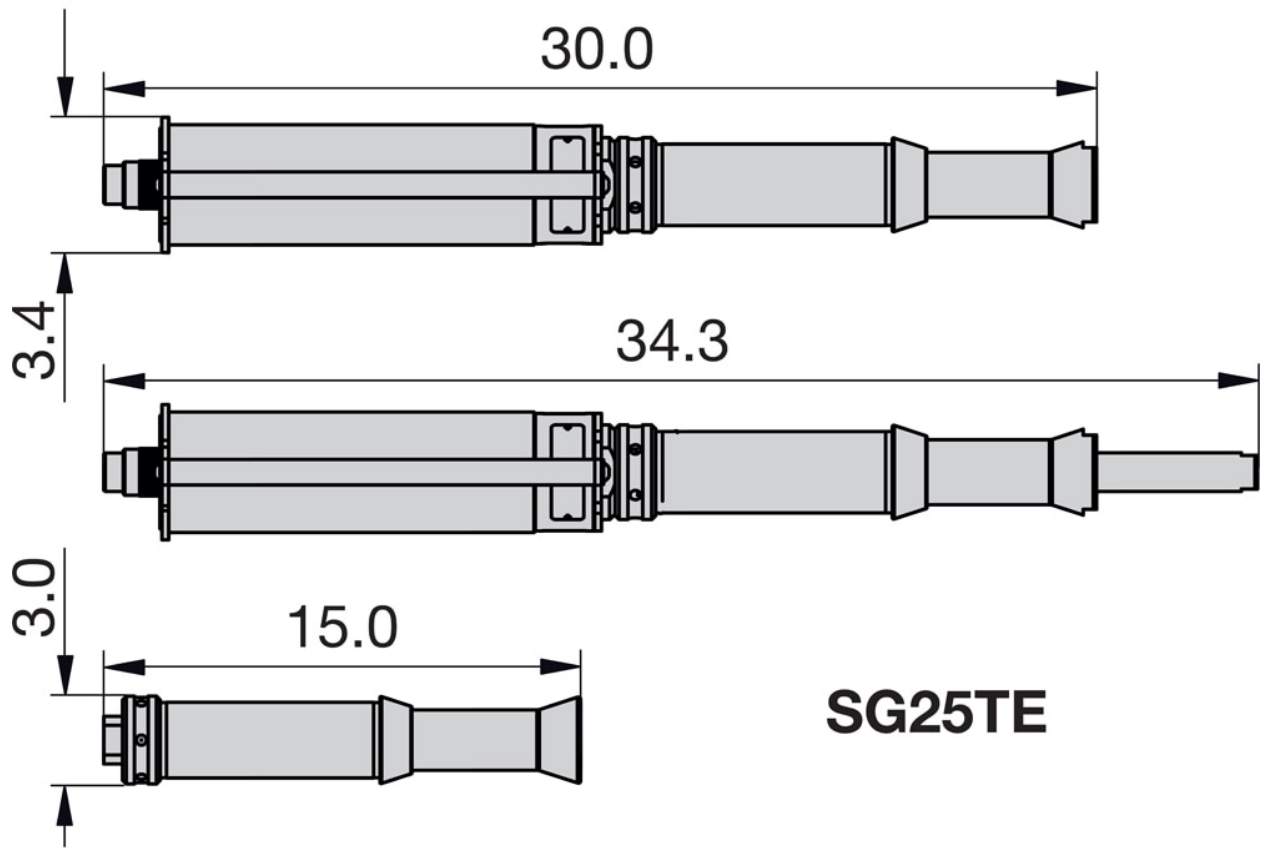

SG25TE

SPACIAL ENVELOPE

