

L-1785
Rev. C
06/98
PC5410

DATE CODES BEGINNING WITH THE LETTER "O".

MODEL NUMBER CODE

- | | | | | | | |
|---|--|---|-------------------|---|--------------------------|---|
| 1 | 2 | 3 | 4 | 5 | 6 | 7 |
| 1. S = swing cylinder
2. T = threaded body
U = upper flange
L = lower flange | 3. R = right swing
L = left swing
S = straight swing | 4. S = single-acting
D = double-acting | 5. 2 = 2 kN force | 6. 1 = imperial body type
2 = metric body type | 7. V = Viton seal option | |

NOTE: You may need special tools to reassemble these swing cylinders. Tool drawings are available on request from Enerpac. To obtain tool drawings, contact the Enerpac Technical Services Department at 1-800-433-2766. Please be prepared to provide the Model Number and the Manufacturing Date Code of each swing cylinder being serviced.

THREADED BODY MOUNTING STYLE

Setting Rotation Direction

- When inserting plunger into base, align desired letter to arrow head stamped on side of cylinder body.
R=right swing rotation
L=left swing rotation
S=straight (no rotation)
- Insert plunger with proper tools. You may have to turn the plunger as you insert it to properly align ball in groove.

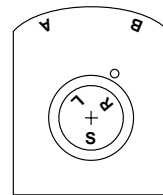

Top View

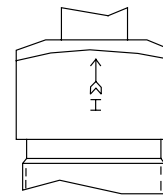

Front View

Single-Acting Models

- Lubricate all seals with Lubriplate prior to assembly.
- Lubricate ball and washer (items 18 & 19) with Lubriplate.
- Torque stop ring (item 2) to 8-15 ft-lbs (11-20 Nm).

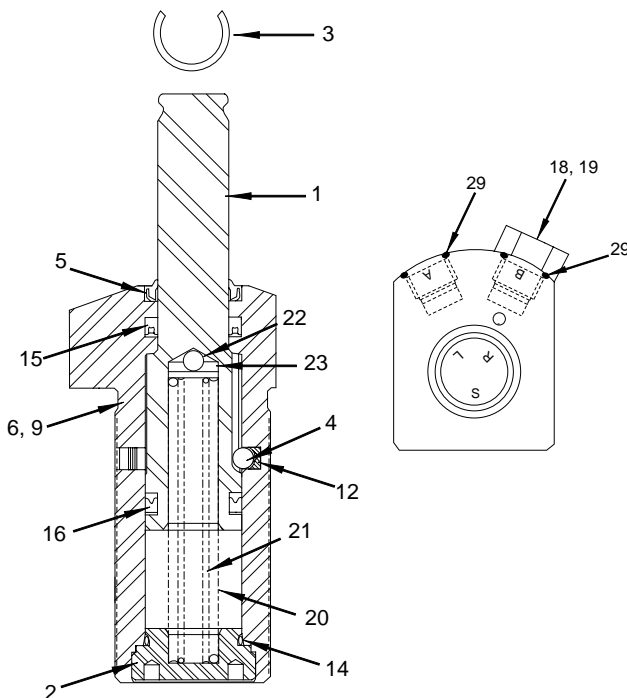

Double-Acting Models

- Lubricate all seals with Lubriplate prior to assembly.
- Torque stop ring (item 2) to 8-15 ft-lbs (11-20 Nm).

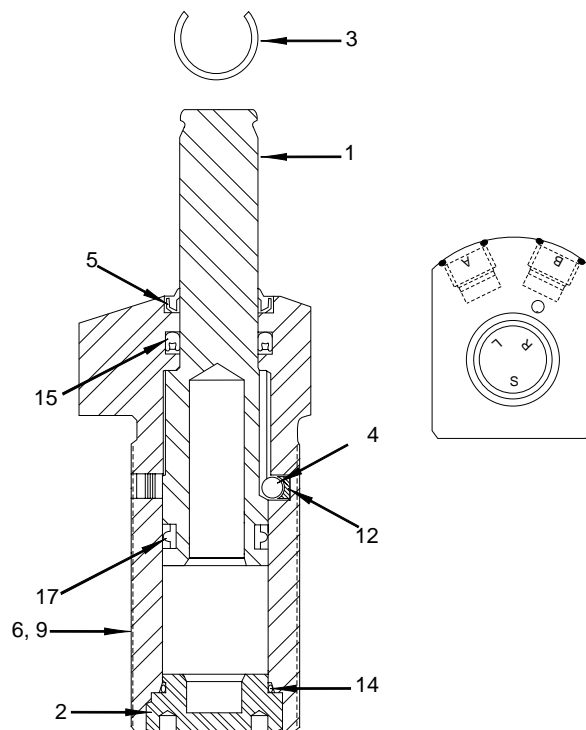

LOWER FLANGE MOUNTING STYLE

Setting Rotation Direction

- When inserting plunger into base, align desired letter to arrow head stamped on side of cylinder body.
 R=right swing rotation
 L=left swing rotation
 S=straight (no rotation)
- Insert plunger with proper tools. You may have to turn the plunger as you insert it to properly align ball in groove.

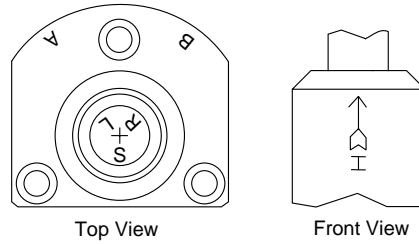

Single-Acting Models

- Lubricate all seals with Lubriplate prior to assembly.
- Lubricate ball and washer (items 18 & 19) with Lubriplate.
- Torque stop ring (item 2) to 8-15 ft-lbs (11-20 Nm).

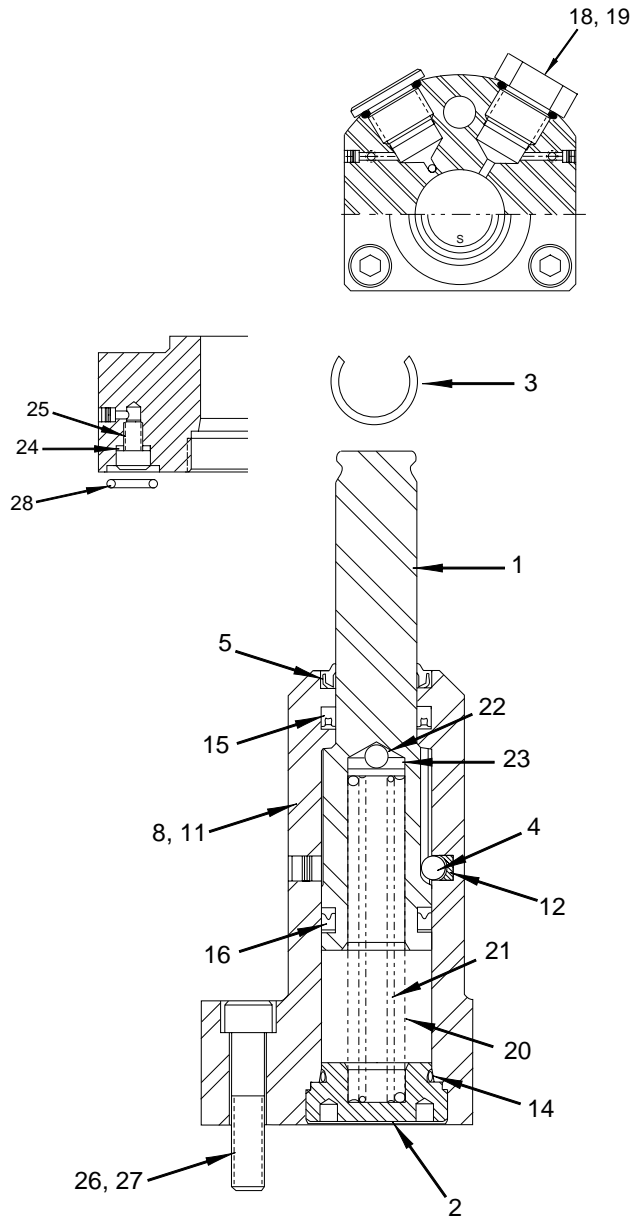

Double-Acting Models

- Lubricate all seals with Lubriplate prior to assembly.
- Torque stop ring (item 2) to 8-15 ft-lbs (11-20 Nm).

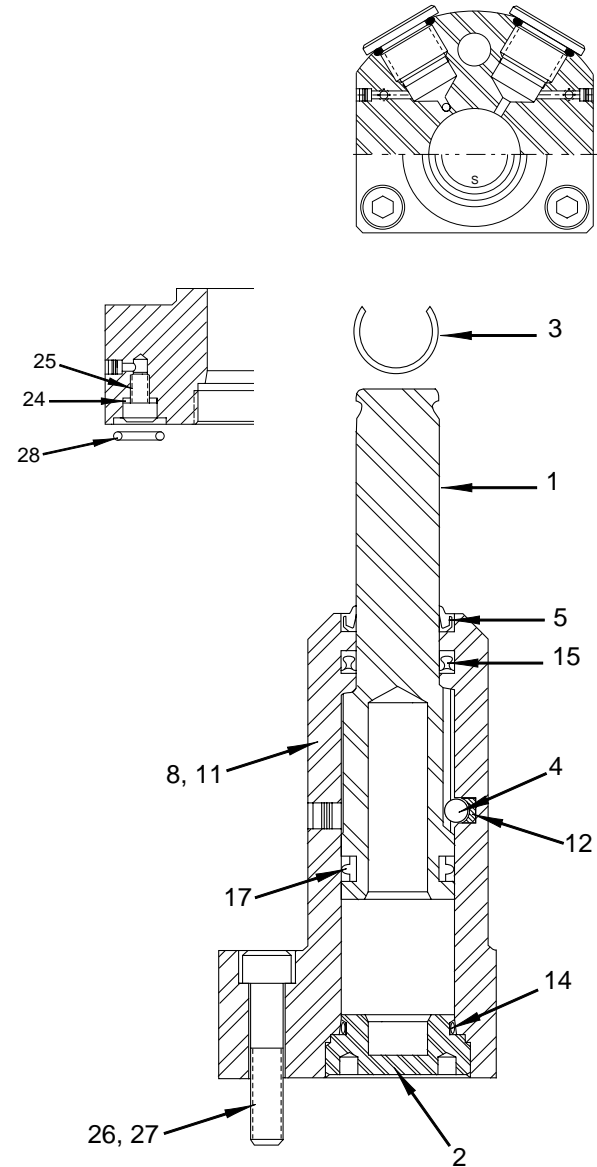

UPPER FLANGE MOUNTING STYLE

Setting Rotation Direction

- When inserting plunger into base, align desired letter to arrow head stamped on side of cylinder body.
 R=right swing rotation
 L=left swing rotation
 S=straight (no rotation)
- Insert plunger with proper tools. You may have to turn the plunger as you insert it to properly align ball in groove.

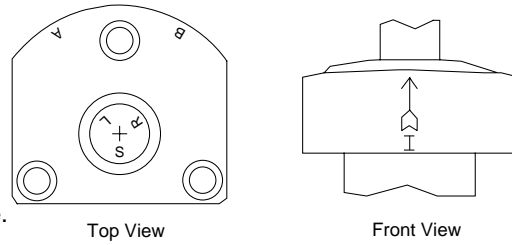

Single-Acting Models

- Lubricate all seals with Lubriplate prior to assembly.
- Lubricate ball and washer (items 18 & 19) with Lubriplate.
- Torque stop ring (item 2) to 8-15 ft-lbs (11-20 Nm).

Double-Acting Models

- Lubricate all seals with Lubriplate prior to assembly.
- Torque stop ring (item 2) to 8-15 ft-lbs (11-20 Nm).

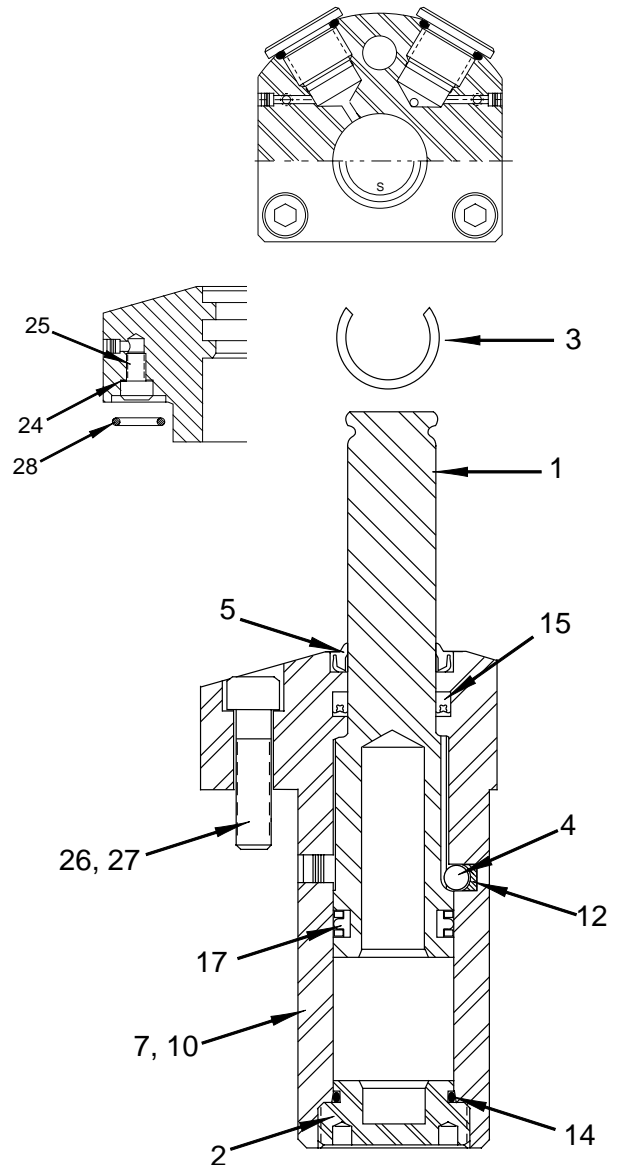
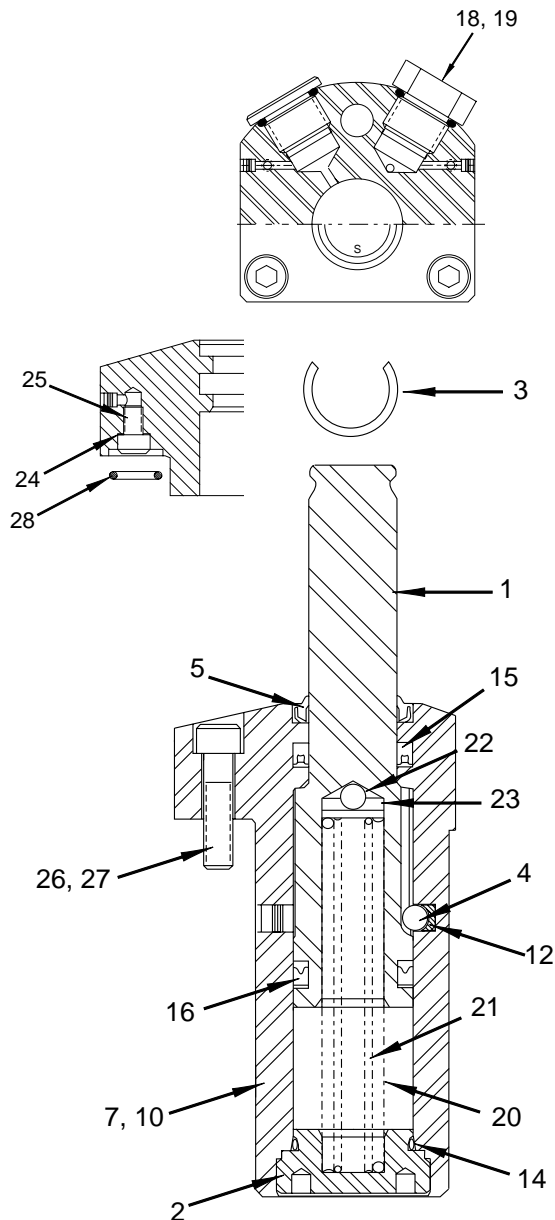

REPAIR PARTS LIST FOR 2 KN SWING CYLINDERS

Item No.	Standard Part Number	Viton Part Number	Quantity	Description
1	PA1233040	PA1233040	1	Plunger
2	PA1251044	PA1251044	1	Stop Ring
3	★ PA1156049	† PA1156049	1	Retaining Ring
4	★ F100016-4	† F100016-4	1	Ball
5	★ PA1132776	† PA1796776	1	Wiper
6	PA1237005SR	PA1237005SR	1	Base-Threaded (imperial)
7	PA1238005SR	PA1238005SR	1	Base-Upper Flange (imperial)
8	PA1239005SR	PA1239005SR	1	Base-Lower Flange (imperial)
9	PA1245005SR	PA1235005SR	1	Base-Threaded (metric)
10	PA1246005SR	PA1246005SR	1	Base-Upper Flange (metric)
11	PA1247005SR	PA1247005SR	1	Base-Lower Flange (metric)
12	★ PA1398054	† PA1398054	1	Ball Cup
14	★ B1013803	† B1013203	1	O-Ring
15	★ PA1148041	† PA1152041	1	U-Cup
16	★ PA1140041	† PA1144041	1	U-Cup (s/a)
17	★ PA1996513	† PA2125515	1	T-Seal (dbl/a), T-Seal, Viton
18	PA1227950SR	PA1227950SR	1	Vent Plug (imperial) (single-acting)
19	PA1267950SR	PA1267950SR	1	Vent Plug (metric) (single-acting)
20	★ PA1406110	† PA1406110	1	Spring (s/a)
21	★ PA1407110	† PA1407110	1	Spring (s/a)
22	★ F100016-4	† F100016-4	1	Ball (s/a)
23	★ PA1200108	† PA1200108	1	Washer (s/a)
24	★ PA1286167	† PA1286167	2	Gasket
25	CCA311028-1A	CCA311028-1A	2	Plug Bolt
26	B1332028	B1332028	3	Bolt (imperial)
27	CCA525028-1A	CCA525028-1A	3	Bolt (metric)
28	★ B1010803	† B1010203	2	O-Ring
29	★ B1007503	† B1005503	2	O-Ring

★ Items included in and available only as part of Repair Kit SS21K (single-acting) or SD21K (double-acting).
 † Items included in and available only as part of Repair Kit SS21KV (single-acting) or SD21KV (double-acting).

Australia

ENERPAC
 Applied Power Australia, Ltd.
 P.O. Box 261 Regents Park
 Sydney, N.S.W. 2143
 Tel: (61) (2) 9743 8988
 Fax: (61) (2) 9743 8648

CIS

Applied Power Moscow
 Leninsky Prospekt 95A
 117313 Moscow, Russia
 Tel: (7)(95) 936 5090
 Fax: (7)(95) 936 2006

**France, Switzerland,
 Turkey, Greece, Africa,
 Middle East**

ENERPAC S.A.
 Parc d'Activitié du Moulin
 de Massy
 1 rue du Saule trapu, BP200
 F-91882 Massy CEDEX
 (Paris) France
 Tel: (33) 1 60 13 68 68
 Fax: (33) 1 69 20 37 50

**Germany, Scandinavia,
 Eastern Europe, Austria,
 Switzerland**

ENERPAC
 Applied Power GmbH
 P.O. Box 30 01 13
 Mündelheimer Weg 51
 40401 Düsseldorf 30
 Germany
 Tel: (49) (211) 47 14 90
 Fax: (49) (211) 4714 928/940

**Holland, Belgium,
 and Luxemburg**

ENERPAC B.V.
 P.O. Box 269, Storkstraat 25
 3900AG Veenendaal
 Holland
 Tel: (31) (318) 535911
 Fax: (31) (318) 525613/526645

Hong Kong

ENERPAC
 Room No. 907, Workingberg
 Commercial Building
 41-47 Marble Road, North Point
 Tel: (852) 561-6295
 Fax: (852) 561-6772

India

ENERPAC
 Hydraulics (India) Pvt Ltd.
 203 Vardhaman Chamber
 Plot #84, Sector 17
 Vashi, New Bombay 400 705
 India
 Tel: 91-22-7631062
 Fax: 91-22-7670309

Italy

ENERPAC
 Applied Power Italiana S.p.A.
 Via Canova, 4
 20094 Corsico (Milano)
 Italy
 Tel: 39 2 45 82 741/2/3
 Fax: 39 2 48 60 12 88

Japan

Applied Power Japan LTD
 10-17 Sasame Kita-cho
 Toda-City
 Saitama 335,
 Japan
 Tel: 81 048 422 2251
 Telex: J26275
 Fax: 81 048 422 0596

Mexico

ENERPAC
 Applied Power Mexico S.A. de C.V.
 Av. Principal La Paz #100
 Fracc. Industrial La Paz
 42084 Pachuca. Hidalgo, Mexico
 Tel: (52) 771 33700
 Fax: (52) 771 83800

Singapore

Applied Power Asia Pte Ltd.
 47 Jalan Pemimpin #01-02
 01-03 Sin Cheong Building
 Singapore 2057
 Thomson Road P.O. Box 114
 Singapore 9157
 Tel: (65) 258 1677
 Fax: (65) 258 2847

South Korea

ENERPAC
 Applied Power Korea Ltd.
 163-12, Dodang-Dong
 Wonmi-gu, Buchun-Shi,
 Kyunggi-Do
 Korea
 Tel: (82) (32) 675 0836
 Fax: (82) (32) 675 3002

Spain, Portugal

ENERPAC
 Applied Power International, S.A.
 Calle de la Imprenta, 7
 Polígono Industrial
 28100 Alcobendas (Madrid)
 Spain
 Tel: (34) 1 661 11 25
 Fax: (34) 1 661 47 89

United Kingdom, Ireland

ENERPAC Ltd. Unit 3
 Colemeadow Road
 North Moons Moat
 Redditch, Worcester B98 9BP
 England
 Tel: 44 01527 598 900
 Fax: 44 01527 585 500

**United States, Canada,
 Latin America and
 Caribbean**

ENERPAC
 13000 West Silver Spring Drive
 Butler, Wisconsin 53007, USA
 Tel: (414) 781-6600
 1-800-433-2766 (End User)
 1-800-558-0530 (Distributor)
 Fax: (414) 781-1049

Canada

Tel: 1-800-426-4129 (End User)
 Tel: 1-800-426-2284 (Distributor)

Latin America and Caribbean

Tel: (414) 781-6600 ext. 263
 Fax: (414) 781-5561



All Enerpac products are guaranteed against defects in workmanship and materials for as long as you own them. Under this guarantee, free repair or replacement will be made to your satisfaction.

For prompt service, contact your Authorized Enerpac Service Center or call toll free:

**In U.S.A. 1-800-558-0530
 In Canada 1-800-426-2284**