

**To Protect Your Warranty, Use Only ENERPAC Hydraulic Oil.**

Enerpac recommends that all kit components be installed to insure optimum performance of the repaired product.

**Key:**

- A. Hydraulic Pressure Gauge (see figure 1)
- B. Manifold / Valve Station (see figure 2)
- C. Hydraulic Oil Fill Plug (see figure 3)
- D. Pump Assembly (see figure 4)
- E. Oil Filter Assembly (see figure 5)
- F. Shuttle Valve Assembly (see figure 6)
- G. Air On-Off Switch Assembly (see figure 7)
- H. Filter / Regulator (see figure 8)
- I. Air On-Off Switch (see figure 9)

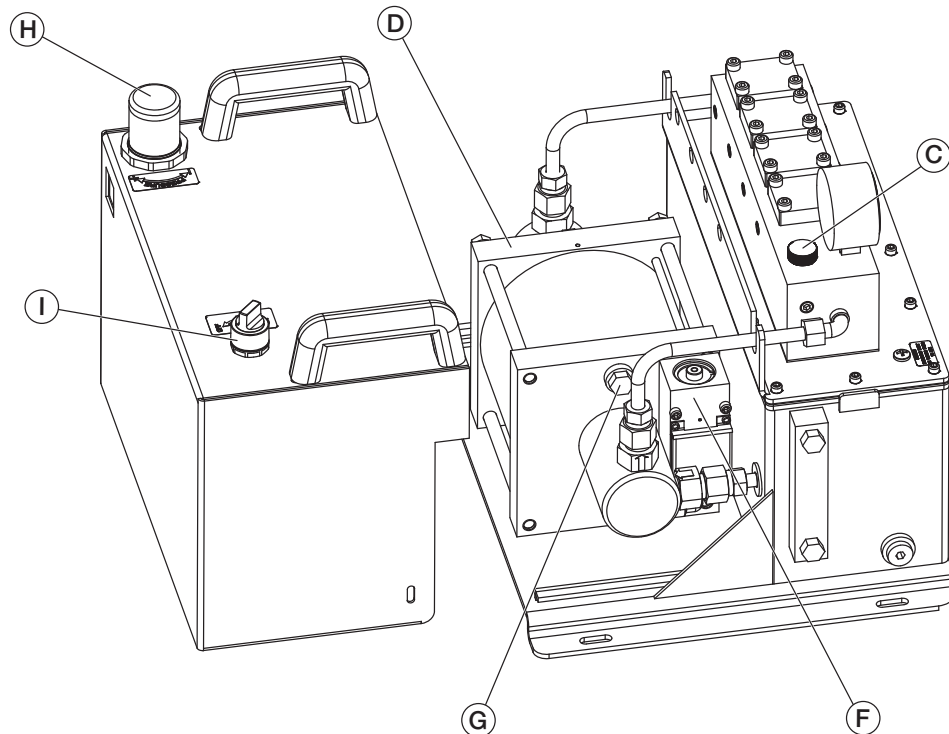
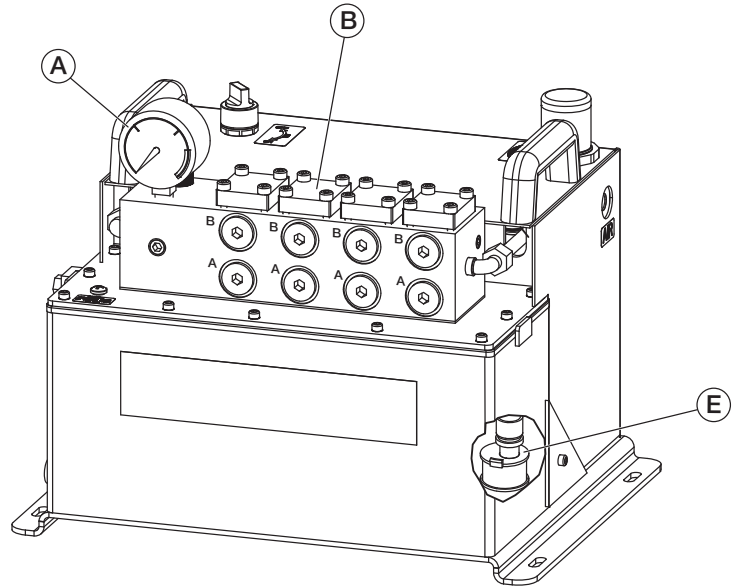

**Figure 1 - Hydraulic Pressure Gauge**

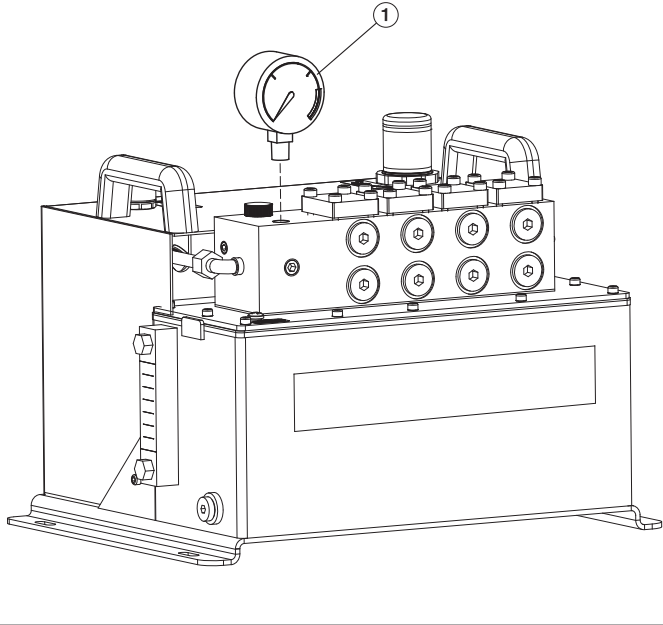

**Parts List for Figure 1**

Item	Part Number	Qty.	Description
1	G2517SL	1	Hydraulic Pressure Gauge

**Notes:**

Apply Teflon tape to threads of gauge.

Torque 1.5 to 3 turns after hand tight, 34 Nm max. [25 ft-lbs].

**Figure 2 - Manifold / Valve Station**

**Notes:**

⚠ Torque to 8-10 Nm [6-8 ft-lbs].

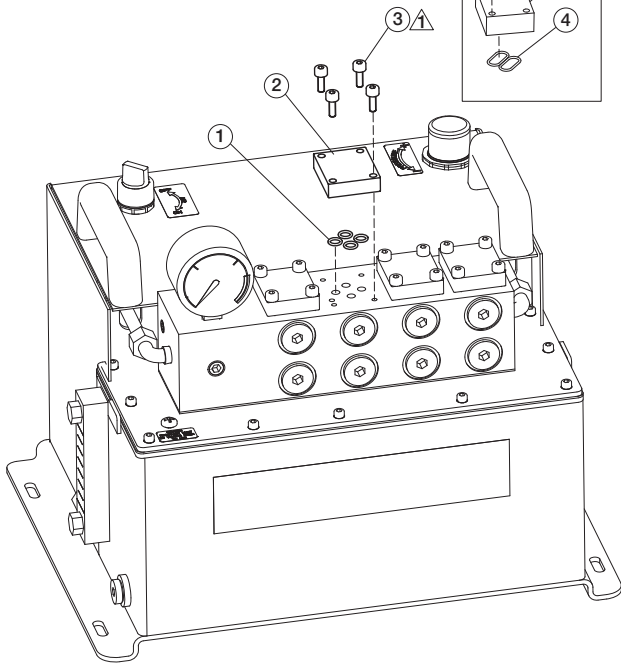
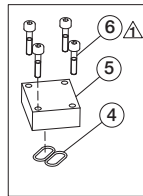

**Parts List for Figure 2**

Item	Part Number	Qty.	Description
1	◆	4	O-Ring (-012)
2	◆	1	Cover Plate, D03
3	◆	4	Socket Hd Cap Screw, #10-24 x 7/8" long
4	♣	2	O-Ring (-016)
5	♣	1	Cross Over plate
6	♣	4	Socket Hd Cap Screw, #10-24 x 1" long

◆ Included in MC1 Cover plate Kit.

♣ Included in MC2 Cross Over Plate Kit.

**Figure 3 - Hydraulic Oil Fill Plug**

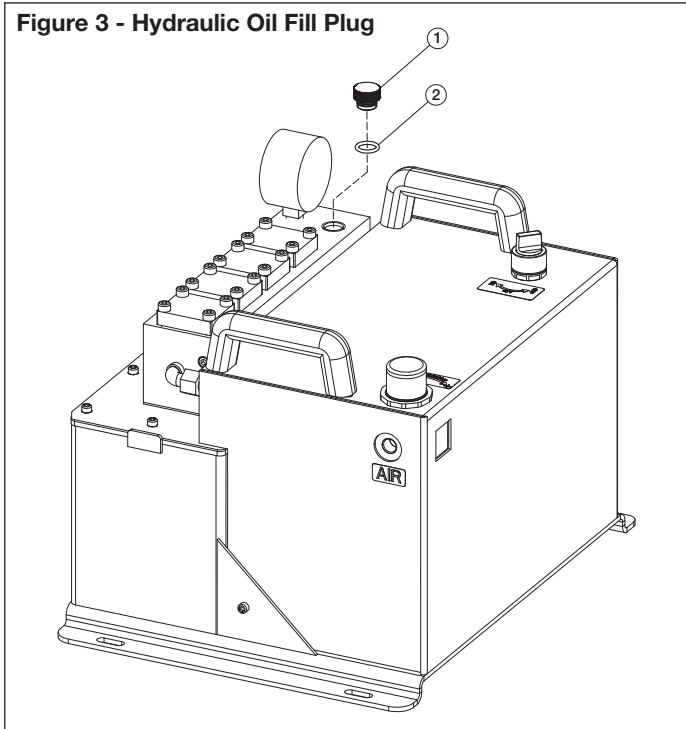

**Parts List for Figure 3**

Item	Part Number	Qty.	Description
1	DW1700900SR	1	Plug
2		1	O-Ring

**Figure 4 - Pump Assembly**

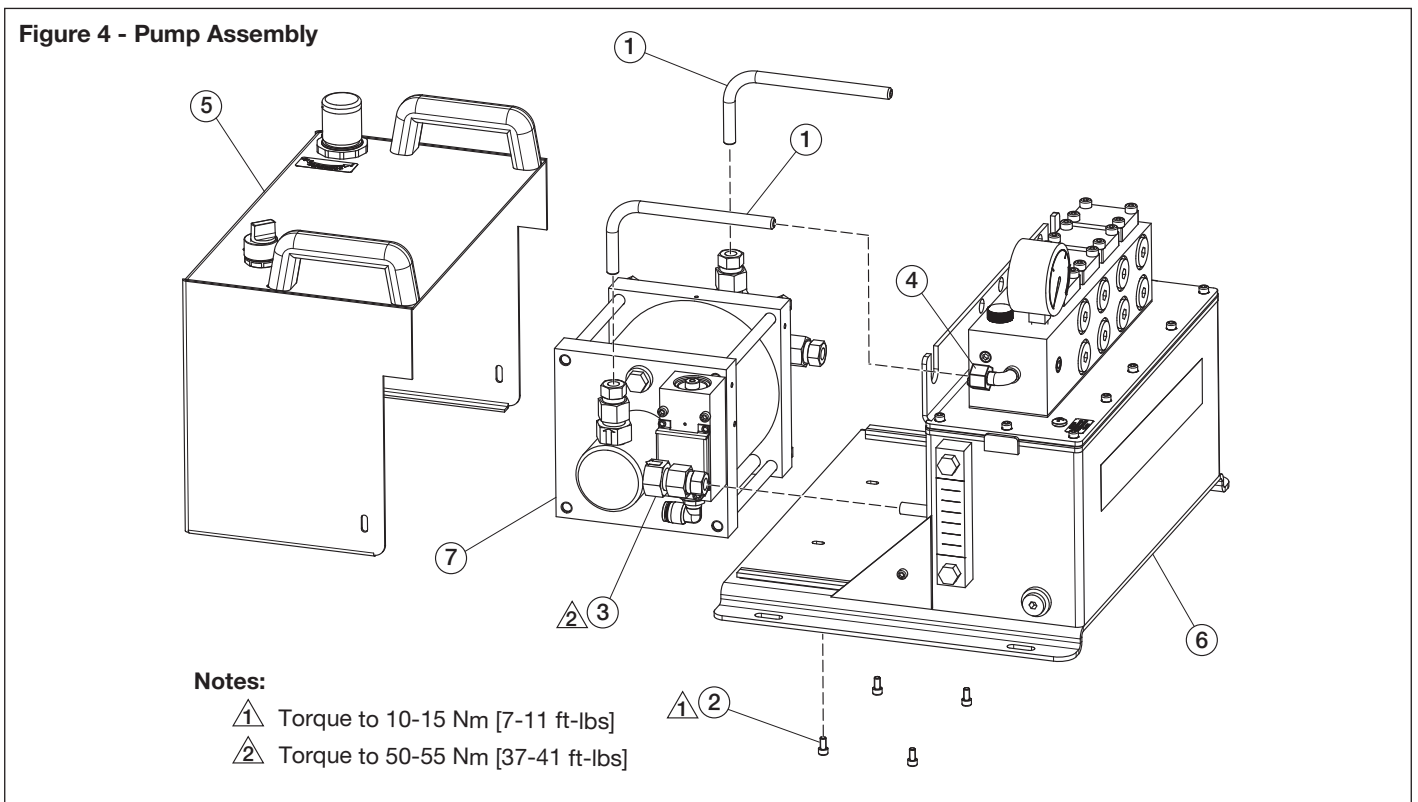

**Notes:**

- ⚠ 1 Torque to 10-15 Nm [7-11 ft-lbs]
- ⚠ 2 Torque to 50-55 Nm [37-41 ft-lbs]

**Parts List for Figure 4**

Item	Part Number	Qty.	Description
1	---	2	Pipe-Elbow
2	---	4	Bolt M5-0.8 x 10 mm LG
3	---	2	Connector
4	---	2	Connector
5	---	1	Cover Assembly
6	---	1	Tank Assembly
7	DX7025900SR	1	Pump Assembly, 70 bar
	DX7026900SR	1	Pump Assembly, 150 bar
	DX7027900SR	1	Pump Assembly, 300 bar

**Figure 5 - Oil Filter Assembly**

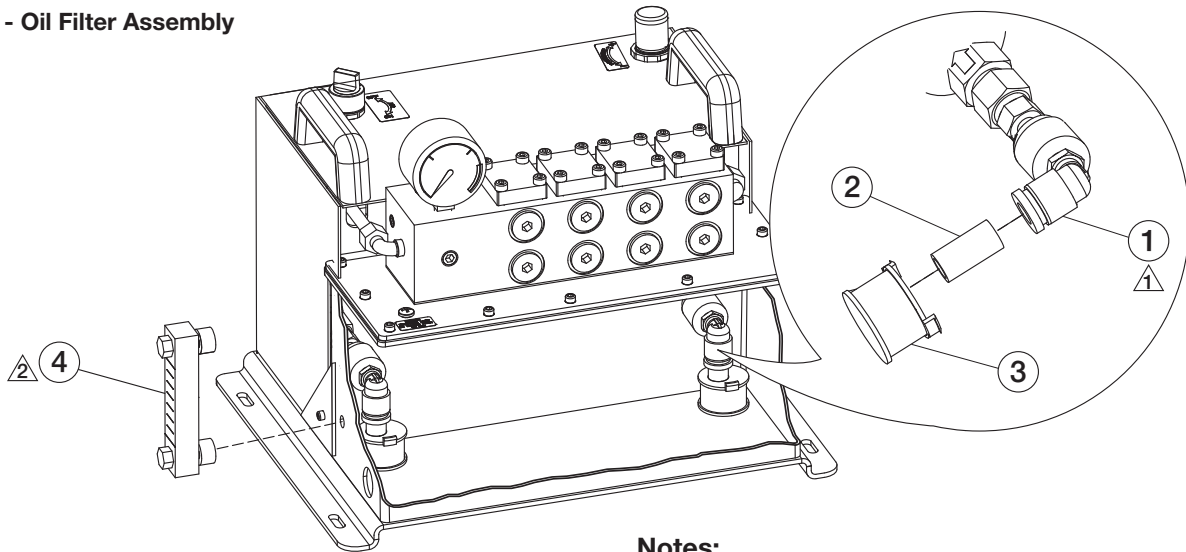

**Notes:**

- ⚠ Torque to 6-8 ft-lbs [8-10 Nm].
- ⚠ Tighten bolts snug tight.

**Parts List for Figure 5**

Item	Part Number	Qty.	Description
1	---	2	Connector
2	---	2	Adapter
3	DC9178118SR	2	Oil Filter (Suction Strainer)
4	DX9153022SR	1	Oil Level Gauge

**Figure 6 - Shuttle Valve Assembly**

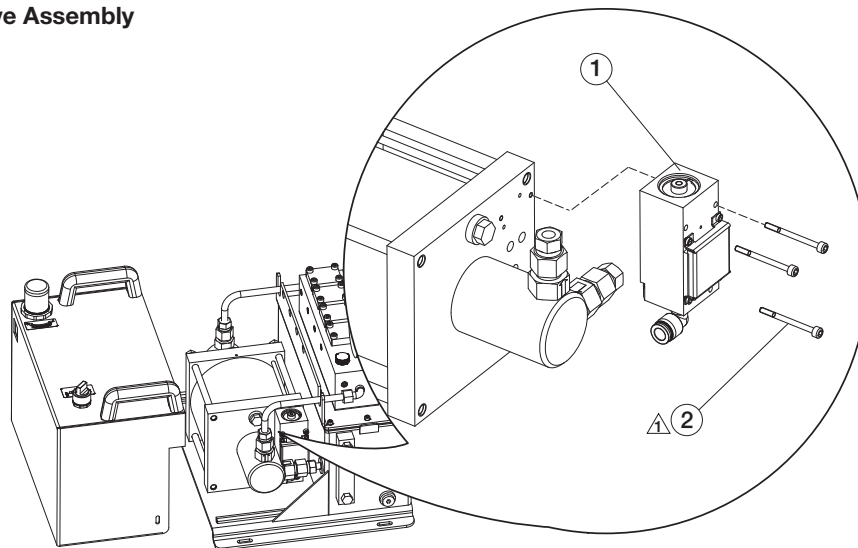

**Notes:**

- ⚠ Torque to 3-5 ft-lbs [5-7 Nm].

**Parts List for Figure 6**

Item	Part Number	Qty.	Description
1	DX7040900SR	1	Air Shuttle Valve Assembly
2	---	3	Bolt, M4 x 0.7 x 50 mm Lg. (included with item 1)

**Figure 7 - Air On-Off Switch Assembly**

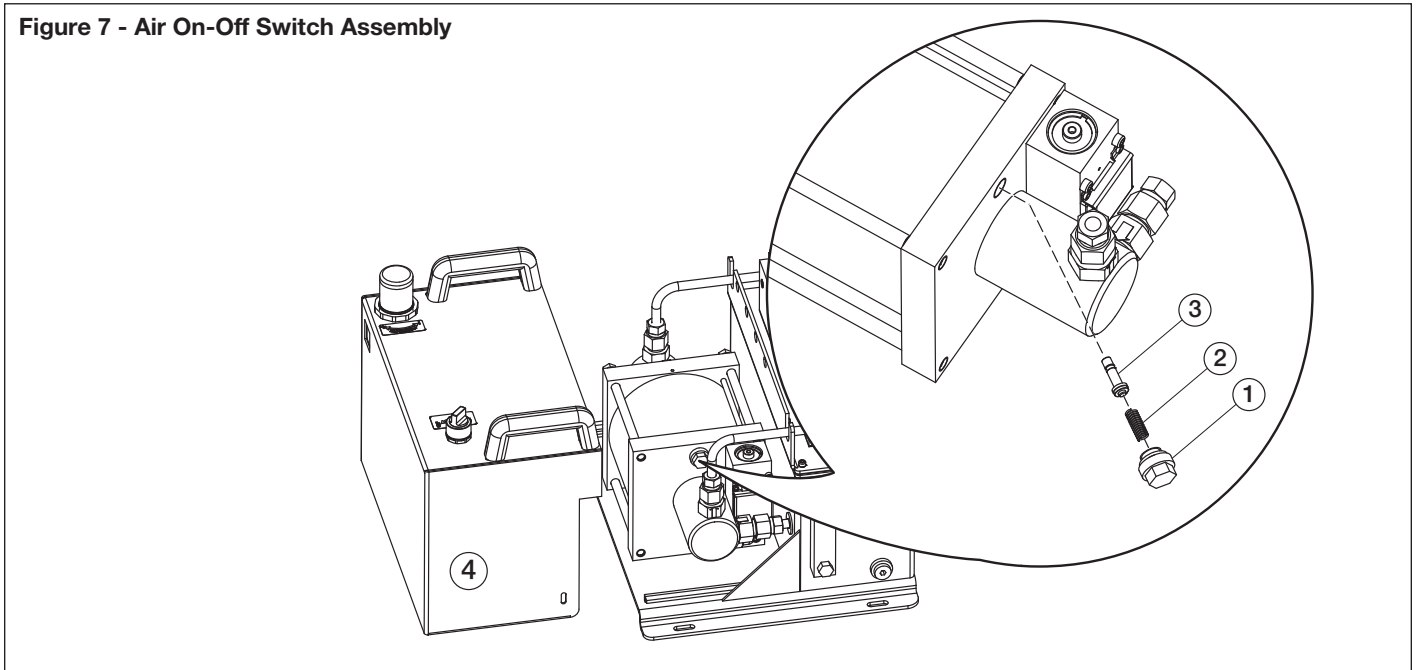

**Parts List for Figure 7**

Item	Part Number	Qty.	Description
1	★	1	Cap Assembly
2	★	1	Coil Spring
3	★	1	Piston Assembly
★ Included in DX7058900SR Air Switch Assembly			

**Figure 8 - Filter / Regulator**

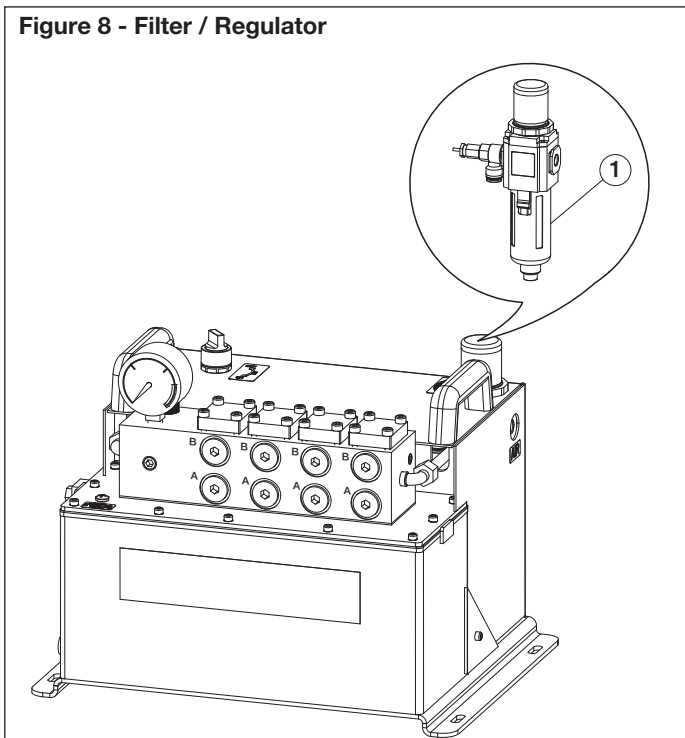

**Parts List for Figure 8**

Item	Part Number	Qty.	Description
1	DX9070118SR	1	Filter/Regulator Assembly
<b>Notes:</b> Pneumatic fittings NOT included with new filter/regulator.			

Figure 9 - Air On-Off Switch

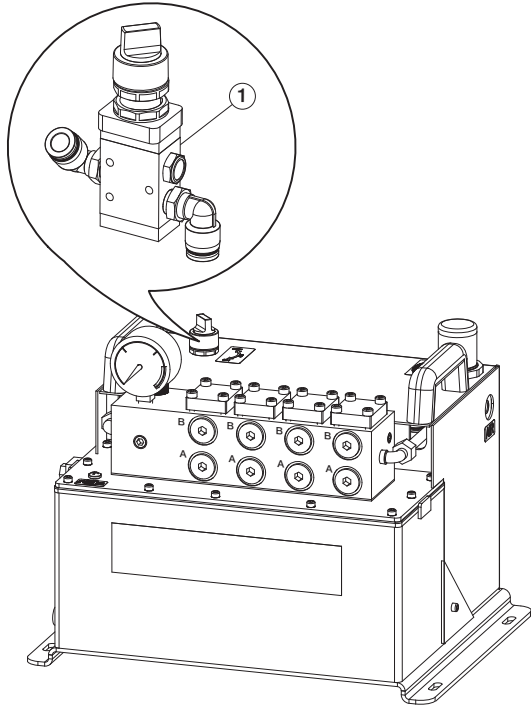

Parts List for Figure 9

Item	Part Number	Qty.	Description
1	DX9044660SR	1	Air On-Off Switch Assembly

**Notes:**

Pneumatic fittings NOT included with new air on-off switch.



