

Specifications

Units:

Imperial

Metric

Maximum Operating Pressure (psi)	10,000
Maximum Spread (in)	11.50
Power Source	Hydraulic
Spreading Force (imperial tons)	0.75
Maximum Spreading Force (ton)	0,75
Maximum Spreading Force (kN)	6
Capacity (imperial tons)	0.75
Tip Clearance (in)	1.26
Cylinder Effective Area (in ²)	2.25
Oil Capacity (in ³)	3.91
Weight (lbs)	25

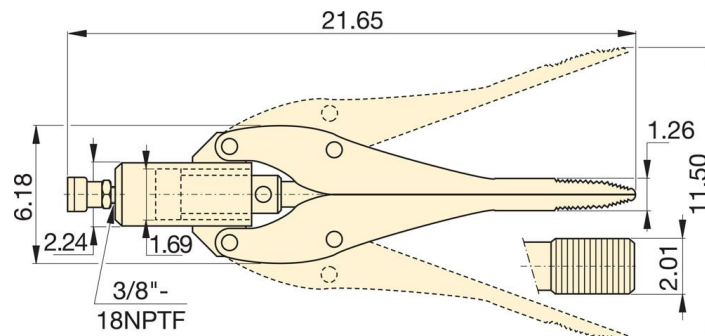

WR-15

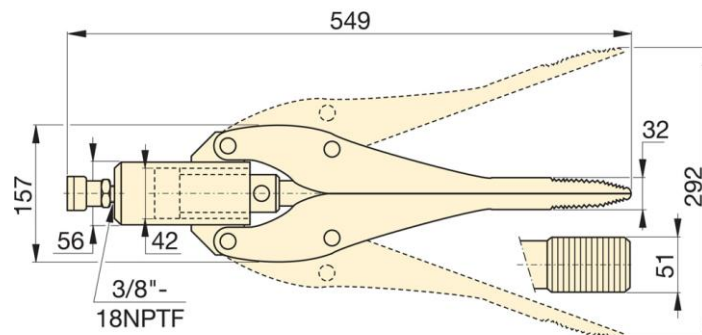

WR-15