



Operation and Maintenance Manual

XC2 Series Cordless Hydraulic Bolting Pumps Models XC2502B and XC2504B

Document Number: L4589

Document Revision: E

Issue Date: January 2024

Language: English EN

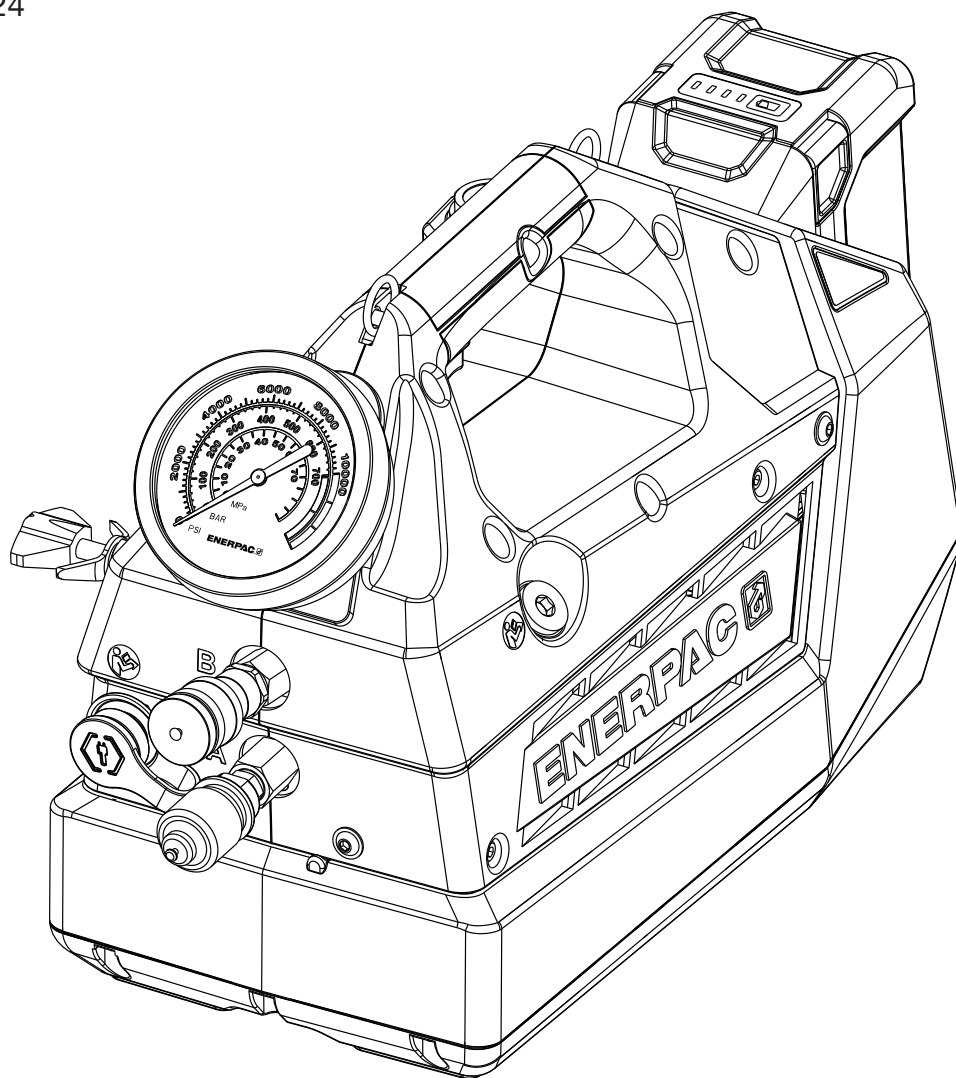
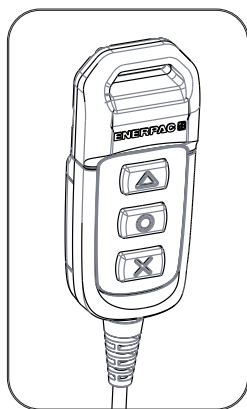

To reduce the risk of injury, user must read and understand this document before use.

ABOUT US

Enerpac is a global market leader in high pressure hydraulic tools, controlled force products, portable machining, on-site services and solutions for precise positioning of heavy loads. As a leading innovator with over a 100-year legacy, Enerpac has helped move and maintain some of the largest structures on earth. When safety and precision matters, elite professionals in industries such as aerospace, infrastructure, manufacturing, mining, oil & gas and power generation rely on Enerpac for quality tools, services and solutions. For additional information, visit www.enerpac.com.

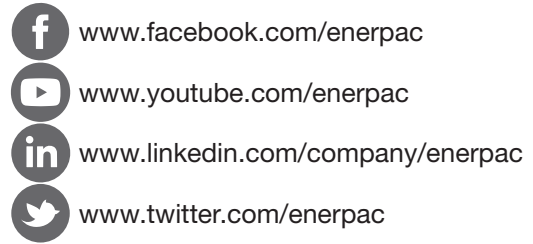

WARRANTY

Refer to the Enerpac Global Warranty document for terms and conditions of the product warranty. Such warranty information can be found at www.enerpac.com.

NAMEPLATE

Refer to the pump nameplate for the product model number, serial number and other applicable information.

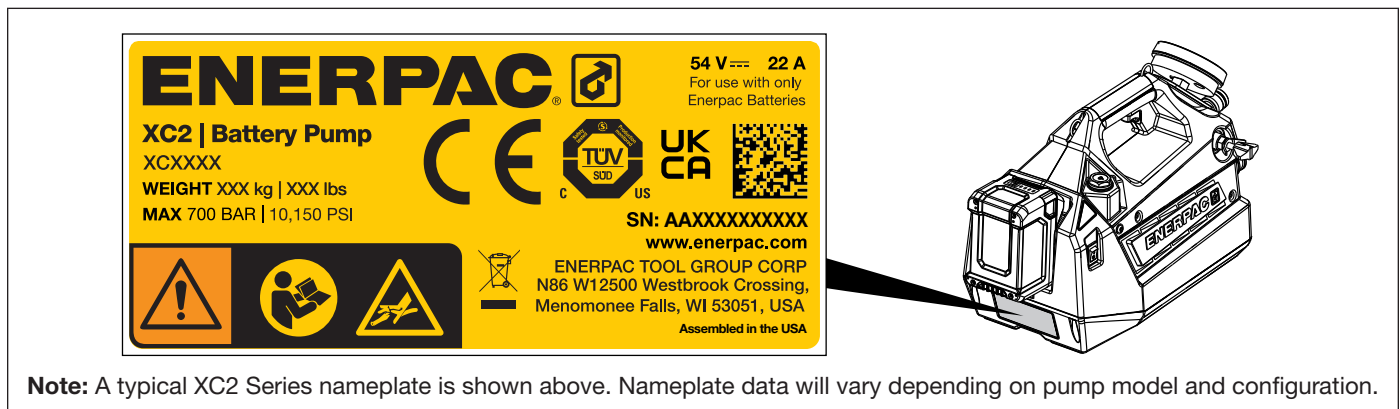

Note: A typical XC2 Series nameplate is shown above. Nameplate data will vary depending on pump model and configuration.

AVAILABLE LANGUAGES

An electronic copy of this document is available online in multiple languages:

- [EN] English - For other languages, visit www.enerpac.com.
- [CS] Čeština - Další jazyky naleznete na adrese www.enerpac.com.
- [DE] Deutsch - Weitere Sprachen finden Sie unter www.enerpac.com.
- [ES] Español - Para otros idiomas visite www.enerpac.com.
- [FI] Suomi - Muita kieliä on osoitteessa www.enerpac.com.
- [FR] Français - Pour toutes les autres langues, rendez-vous sur www.enerpac.com.
- [IT] Italiano - Per altre lingue visitate il sito www.enerpac.com.
- [JA] 日本語 - その他の言語はwww.enerpac.comでご覧いただけます。
- [KO] 한국어 - 이 지침 시트의 다른 언어 버전은 www.enerpac.com.
- [NL] Nederlands - Ga voor de overige talen naar www.enerpac.com.
- [NO] Norsk - For alle andre språk henviser vi til www.enerpac.com.
- [PL] Polski - Inne wersje językowe można znaleźć na stronie www.enerpac.com.
- [PT] Português - Para outros idiomas consulte www.enerpac.com.
- [RO] Română - Per altre lingue visitate il sito www.enerpac.com.
- [SV] Svenska - För andra språk, besök www.enerpac.com.
- [ZH] 中文 - 如需其他语言, 请前往 www.enerpac.com.

CONTENTS

PAGE

- 1.0 SAFETY..... 4
- 2.0 COMPLIANCE 6
- 3.0 PRODUCT DATA..... 7
- 4.0 FEATURES AND COMPONENTS 9
- 5.0 DESCRIPTION 10
- 6.0 BATTERY 11
- 7.0 OPERATION..... 12
- 8.0 MAINTENANCE..... 16
- 9.0 CLEANING 18
- 10.0 STORAGE 18
- 11.0 SAFE DISPOSAL PROCEDURE 19
- 12.0 FIRMWARE UPDATES 19
- 13.0 TROUBLESHOOTING 19
- 14.0 REPAIR PARTS SECTION..... 23

1.0 SAFETY

Read all instructions carefully. Follow all recommended safety precautions to avoid personal injury as well as damage to the product and / or damage to other property. Enerpac cannot be responsible for any damage or injury from unsafe use, lack of maintenance, or incorrect operation. Do not remove warning labels, tags, or decals. In the event that any questions or concerns arise, contact Enerpac or a local Enerpac distributor for clarification.

Save these instructions for future use.

Appropriate training in the safe use of high pressure, high force hydraulic tools is required prior to the operation of the pump. If training is needed, contact your local Enerpac distributor or authorized service center for information about a Enerpac hydraulic safety training course.

This manual follows a system of safety alert symbols, signals, words, and safety messages to warn the user of specific hazards. Failure to comply with these warnings could result in death or serious personal injury, as well as damage to the equipment or other property.



The Safety Alert Symbol appears throughout this manual. It is used to alert you to potential physical injury hazards. Pay close attention to Safety Alert Symbols and obey all safety messages that follow this symbol to avoid the possibility of death or serious injury.

Safety Alert Symbols are used in conjunction with certain Signal Words that call attention to safety messages or property damage messages and designate a degree or level of hazard seriousness. The Signal Words used in this manual are WARNING, CAUTION and NOTICE.

WARNING Indicates a hazardous situation that, if not avoided, could result in death or serious personal injury.

CAUTION Indicates a hazardous situation that, if not avoided, could result in minor or moderate personal injury.

NOTICE Indicates information considered important, but not hazard related (e.g. messages related to property damage). Please note that the Safety Alert Symbol will not be used with the signal word.

1.1 Hydraulic Safety Precautions



Failure to observe and comply with the following precautions could result in death or serious personal injury. Property damage could also occur.

1.1.1 General Hydraulic Safety Precautions

- Do not remove, modify or disable the pump's user adjustable pressure relief valve.
- Never set the pressure relief valve to a higher pressure than the maximum rated working pressure of the pump.

- Never remove, modify, disable or readjust the pump's internal safety relief valve.
- Do not handle pressurized hydraulic hoses. Escaping oil under pressure can penetrate the skin. If oil is injected under the skin, see a doctor immediately.
- Do not pressurize uncoupled hydraulic couplers.
- Do not exceed the pump's maximum pressure rating of 10,150 psi [700 bar]. Overloading may cause equipment failure and possible personal injury.
- The system operating pressure must not exceed the pressure rating of the lowest rated component in the system. All hoses, fittings and couplers used with the pump must be rated at 10,150 psi [700 bar] minimum.
- Install pressure gauge(s) in the system to monitor operating pressure. It is your window to see what is happening in the system.
- Wear personal protective equipment (P.P.E.) when operating hydraulic equipment.
- Always wear eye protection. Safety equipment such as dust mask, non-skid safety shoes, hard hat, or hearing protection used for appropriate conditions will reduce personal injuries.
- Immediately replace worn or damaged parts with genuine Enerpac parts. Enerpac parts are designed to fit properly and to withstand high loads. Non-Enerpac parts may break or cause the pump to malfunction. Personal injury and property damage may also occur.

CAUTION

Failure to observe and comply with the following precautions could result in minor or moderate personal injury. Property damage could also occur.

- Do not use or repair damaged hydraulic hoses. Avoid sharp bends and kinks when routing hydraulic hoses. Using a bent or kinked hose will cause severe back-pressure. Sharp bends and kinks will internally damage the hose, leading to premature hose failure.
- Do not drop heavy objects on hydraulic hoses. A sharp impact may cause internal damage to hose wire strands. Applying pressure to a damaged hose may cause it to rupture.
- Do not lift hydraulic equipment by the hoses or swivel couplers. Use the carrying handle or strap.
- Keep hydraulic equipment away from flames and heat. Excessive heat will soften packings and seals, resulting in fluid leaks. Heat also weakens hose materials and packings.
- Protect all hydraulic equipment from weld spatter.

NOTICE Hydraulic equipment must only be serviced by a qualified hydraulic technician. For repair service, contact an Enerpac authorized service center in your area.

1.1.2 Bolting Safety Precautions

WARNING

Failure to observe and comply with the following precautions could result in death or serious personal injury. Property damage could also occur.

- Never attempt to connect or disconnect hoses while the pump is on and/or the system is pressurized.
- Always be sure that the pump is stopped and all pressure is fully relieved (0 psi/bar) before disconnecting or connecting hydraulic hoses. The sudden and uncontrolled release of pressurized oil could occur if hoses are disconnected while under pressure.
- Be certain that all hose couplers are fully connected at both the pump and wrench before applying any hydraulic pressure. If the couplers are not fully connected, oil flow will be blocked, and the drive unit could be subjected to excessive hydraulic pressures. Catastrophic failure of wrench or pump could result.
- Follow and understand all safety information contained in the torque wrench operation manual and in any other documentation provided by the torque wrench manufacturer. Follow and understand all operation, care and maintenance instructions applicable to the torque wrench being used.
- Be aware that a nut or bolt that breaks off during operation of the pump and wrench may become a high velocity projectile.

1.2 Battery Operated Pump Safety Precautions

WARNING

Failure to observe and comply with the following precautions could result in death or serious personal injury. Property damage could also occur.

- Do not use a battery operated pump in an explosive atmosphere, such as in the presence of flammable liquids, gases, or dust. Sparks and electrical arcing could ignite combustible vapors or airborne dust.
- Do not expose the pump to rain, water spray or wet conditions. Water entering the pump will increase the risk of electric shock and may damage the motor and other components. The pump can be used outdoors, but should be brought inside in the event of rain or other moisture.
- To avoid accidental pump startup, ensure that the pump power switch is in the OFF (O) position before moving or transporting the pump. Never carry the pump with your hand or fingers on the trigger switch.

- Ensure that the pump power switch is in the OFF (O) position before performing inspections, maintenance procedures, repairs or cleaning the pump. As an alternative, remove the battery from the pump.
- Battery power will remain connected to some electrical components inside the pump even when the pump power switch is in the OFF (O) position. For this reason, always remove the battery from the pump before opening the pump housing for any reason. All servicing must be performed only by qualified personnel with appropriate training and expertise, following standard shop safety precautions.
- Use insulated tools and wear electrician's gloves if it is necessary to troubleshoot the pump or observe operation with the pump housing removed (qualified personnel only).
- Do not use the pump if the trigger switch or pendant controls (if equipped) do not turn the motor on and off. Any power tool that cannot be controlled with the trigger switch or pendant controls is dangerous and must be repaired before being used.
- Use the Enerpac XC2 Series pump only with the specified Enerpac 54 volt Li-Ion battery. Use of any other battery may create a risk of injury and fire.
- When battery is not in use, keep it away from other metal objects like paper clips, coins, keys, nails, screws, or other small metal objects that can make a connection from one terminal to another. Shorting the battery terminals together may cause burns or a fire.
- The battery cells may develop a small leak under extreme usage or temperature conditions. Avoid contact with battery liquid. Liquid ejected from the battery may cause irritation or burns. Refer to Section 1.3 for battery first aid instructions.
- If battery case is broken or damaged and/or if leakage occurs, do not reinstall the battery on the pump. Replace with a new battery.
- Recharge the battery only with the specified Enerpac battery charger. A charger that is suitable for one type of battery may create a risk of fire when used with another battery.
- Separate manuals are provided with the battery and battery charger and are also available online at www.enerpac.com. Read and understand all information contained in these manuals. Observe and comply with all communicated safety precautions when using the battery or charger.
- Remove the battery from the pump before storing the pump.
- The battery and battery charger have no serviceable parts. Do not attempt to disassemble or repair these items.

1.3 Battery First Aid Instructions





- If battery liquid comes in contact with skin, wash immediately with soap and water, then neutralize with lemon juice or vinegar.
- If battery liquid gets in your eyes, flush with clean water for a minimum of 10 minutes, then seek immediate medical attention.
- If battery liquid is swallowed, seek immediate medical attention.

1.4 Symbols

Various pictorial symbols are affixed to the pump or molded directly into the pump housing or components. Additional pictorial symbols are located on the battery and battery charger nameplates.

In some instances, these symbols may advise the user of potentially hazardous situations. Other symbols may be informational only. Understand the meaning of each symbol before using the pump.

Selected symbols are shown in the following chart:

Symbol	Definition
	Risk of electric shock. High voltage.
	Device shall not be exposed to high heat, fire/flame, or any heat source.
	Read instruction manual. Save instructions for future use.
	Do not expose device to rain, water or moisture.
	Do not dispose of device in trash.

1.5 Labels

Make sure all labels and decals are legible and securely affixed to the pump. If worn or missing, obtain replacements from Enerpac.

1.6 State of California Proposition 65 Warning (pump)

WARNING The pump uses hydraulic oil as the fluid medium. Hydraulic oils contain ethylbenzene, which may cause cancer and reproductive harm. Hydraulic oils need to be handled carefully, so that contact is avoided.

A warning decal is affixed to the pump, informing the operator of these risks. For additional information, go to www.P65Warnings.ca.gov.

1.7 State of California Proposition 65 Warning (battery)

WARNING The battery used with the pump can expose you to chemicals including cobalt lithium manganese nickel oxide and carbon black, which are known to the State of California to cause cancer and reproductive harm. For additional information go to www.P65Warnings.ca.gov.

2.0 COMPLIANCE

2.1 Compliance Statements

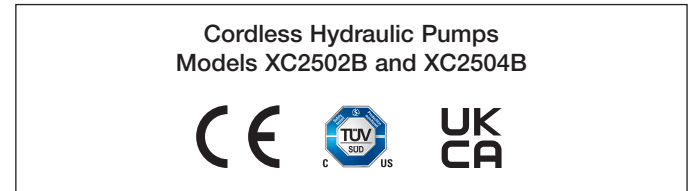

Enerpac declares that the model XC2502B and XC2504B cordless hydraulic pumps have been tested and conform to applicable standards and are approved to carry the CE, TÜV and UKCA certification marks.

NOTICE For all pumps, a copy of the product’s EU Declaration of Conformity is enclosed with each shipment. A copy of the UK Self-Declaration of Conformity is also enclosed.

2.2 Electromagnetic Compatibility (EMC)

The model XC2504B and XC2504B cordless hydraulic pumps have been tested and certified to conform to CE-EMC, FCC, and Japanese EMC emission and immunity standards.

NOTICE The pump may stop running and become unresponsive if electromagnetic interference (EMI) between 80 MHz and 400 MHz is present. The recommended action is to remove the source of the interference. If this is not possible, repositioning the pump may restore functionality.

2.3 Battery Safety Certifications

Refer to the separate battery manual for additional certifications pertaining to the Li-Ion battery used with the pump.

2.4 IP Rating

The model XC2504B and XC2504B cordless hydraulic pumps carry an IP20 ingress protection rating:

- The pump is resistant to dust or objects that are over 12.5 mm [0.49 inch] in size.
- The pump has no protection against liquid entry, such as rain or water-spray.
- The pump can be used outdoors, but should be brought inside in the event of rain or other moisture.

3.0 PRODUCT DATA

3.1 Specifications

Pump Models	Control Valve	For Use With:	Hydraulic Connections*	Operating Temp Range**		Motor Rating		Motor Speed	Sound Pressure***
				°F	°C	hp	kW	RPM	dBA
XC2502B XC2504B	Electric Solenoid Operated, 4-Way, 2-Position	Compatible Hydraulic Torque Wrenches	1/4" NPTF	+14 to +122	-10 to +50	0.94	0.70	14,000-18,000	83

* Hydraulic port thread size. Enerpac Spin-On hydraulic couplers are included with pump.

** At 85% relative humidity.

*** Typical. Sound level will vary depending on pump speed and load.

3.2 Pressure and Flow

Pump Models	Maximum Hydraulic Operating Pressure*		Flow Rate (also see Section 3.3)						Relief Valve Adjustment Range	
	psi	bar	At No Load		At 2000 psi [138 bar]		At 10,150 psi [700 bar]		psi	bar
			in ³ /min	l/min	in ³ /min	l/min	in ³ /min	l/min		
XC2502B XC2504B	10,150	700	160	2.6	50	0.82	20	0.33	1,000 - 10,150	69 - 700

*Maximum system pressure is limited to approximately 10,400 -10,800 psi [717 - 744 bar] by an internal safety relief valve.

3.3 Performance Graphs

MODELS XC2502B & XC2504B (IMPERIAL)

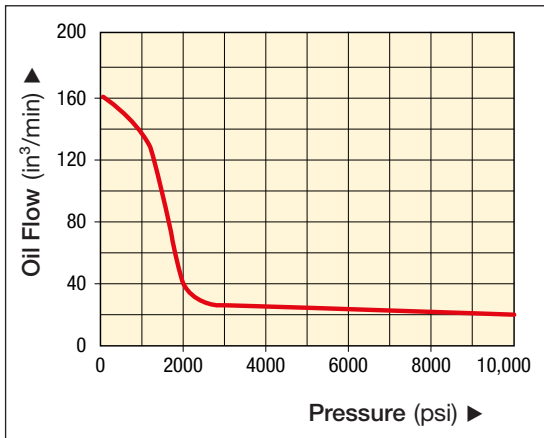

MODELS XC2502B & XC2504B (METRIC)

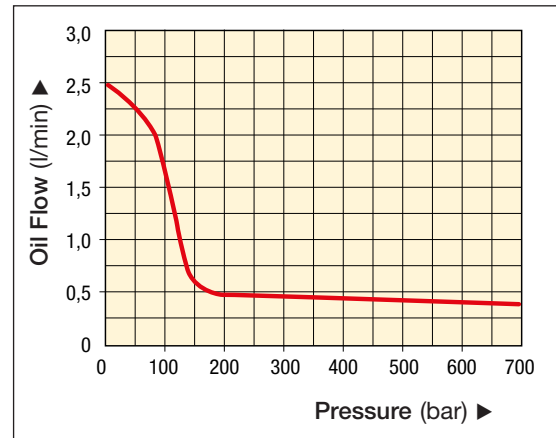

Note: Graphs show typical pump pressure/flow curves.

3.4 Reservoir Capacities and Pump Weights

Pump Model Number	Pump Weight*		Reservoir Usable Oil Capacity		Hydraulic Oil
	lb	kg	in ³	l	
XC2502B	33.7	15.3	120	2.0	Enerpac HF
XC2504B	37.2	16.9	240	4.0	

*Approximate weight of pump with oil in reservoir, and with battery installed. Weight of battery is approximately 3.5 lb [1.6 kg].

3.5 Battery and Battery Charger

Pump Model Number	Item	Region/Country	Enerpac Model No.
XC2502B and XC2504B	Battery, 54V, Enerpac Lithium-Ion, 4.0 Ah, 216 Wh	(all)	EBH544
	Charger (includes AC power cord for selected region or country)	North America 115V	EC1F541B
		Europe 230V	EC1F542E
		Australia 230V	EC1F542A
	Charger AC power cord for Japan (order separately if needed)	Japan 100V	ECC541N
Charger AC power cord for UK (order separately if needed)	United Kingdom 240V	ECC542U	

Note: Battery and charger may be included with pump or may need to be purchased separately (varies depending on how pump was ordered). Charger power input is 100-240 VAC, 50-60 cycles, auto voltage sensing. Charger AC power cord (detachable) will vary depending on region/country and voltage. Refer to Figure 27 of this manual and also to the separate battery and charger manuals for additional information.

3.6 Selected Pump Accessories (optional equipment)

Pump Model Numbers	Item	Enerpac Model No.
XC2502B and XC2504B	Pendant Extension Cord, 10 ft [3 m]	CC010
	Shoulder Strap, XC2 Series Pumps	SSTRP55

Note: Refer to Enerpac website or catalog for a complete description of available pump accessories.

3.7 External Dimensions

Item	Dimension		Models XC2502B & XC2504B
	inch	mm	
A	9.5	242	
B	8.8	224	
C	20.5	521	
D	17.8	453	
E	12.1	308	

Note: Dimensions are the same for both pump models. Dimensions shown are for reference only and may vary slightly from pump to pump.

4.0 FEATURES AND COMPONENTS

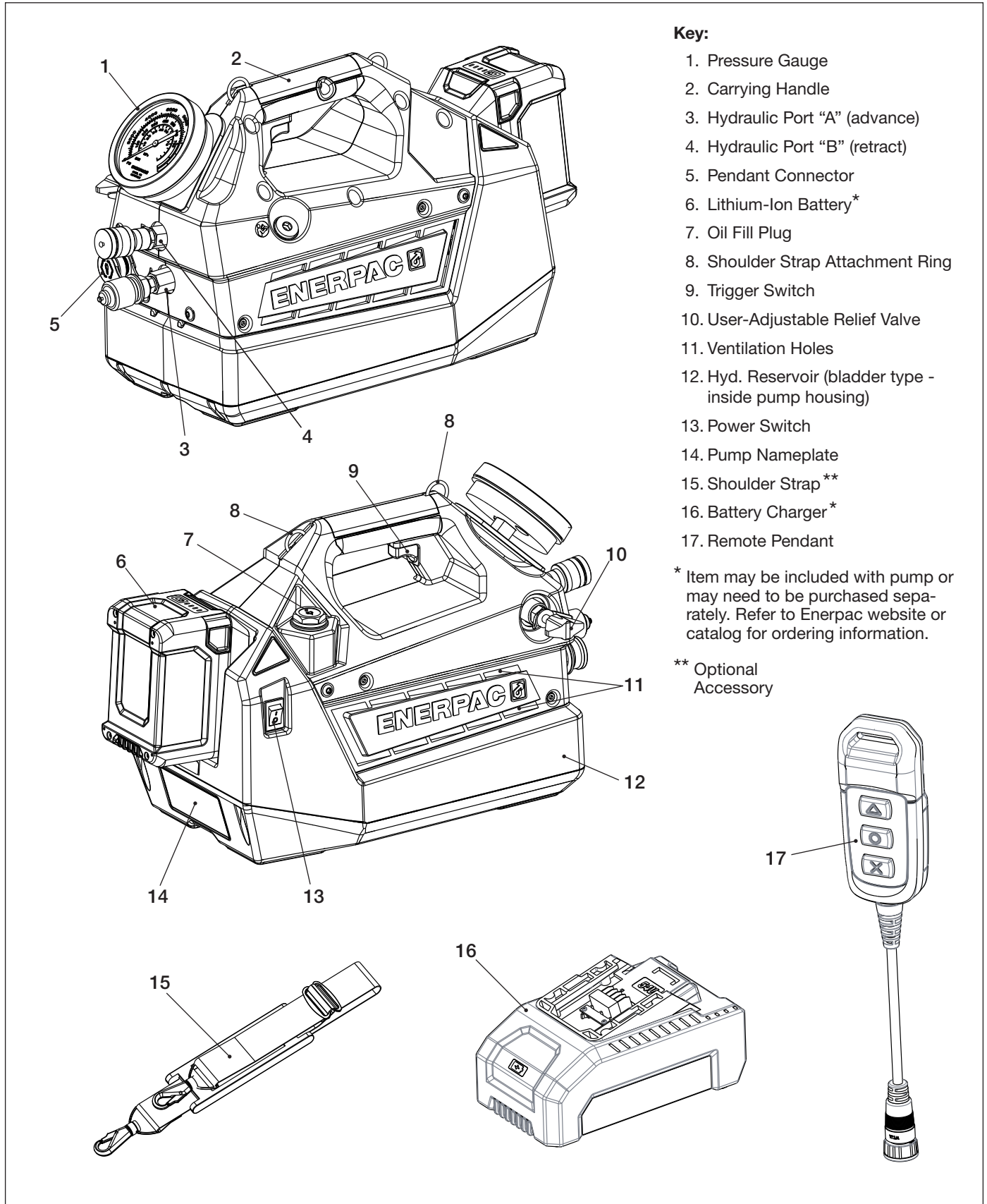

Figure 1: Features & Components, Models XC2502B and XC2504B

5.0 DESCRIPTION

The Enerpac XC2 Series cordless torque wrench pumps combine the performance of a powered pump with the portability of a hand operated pump.

Designed for use with hydraulic torque wrenches, models XC2502B and XC2504B feature a high-performance, brushless DC electric motor, two-stage hydraulic pump element and an electric solenoid operated control valve.

An integral bladder type oil reservoir allows pump operation in any position and helps prevent contamination. Model XC2502B features a two liter [120 in³] oil reservoir. Model XC2504B contains a four liter [240 in³] oil reservoir, for use with larger capacity torque wrenches.

A remote pendant with a 20 foot [6 m] cord allows the user to operate the pump at a safe distance away from the fastener being torqued. A pump-mounted trigger switch is also provided for situations where use of a pendant is not practical.

Power is supplied by a rechargeable 54 V, 4 Ah Lithium-Ion battery. The Lithium-Ion battery is capable of providing extended run times, even under demanding conditions.

An integrated carrying handle and removable shoulder strap (optional accessory) allow for easy portability.

INSTALLATION & SETUP

5.1 Receiving Instructions

Visually inspect all components for shipping damage. Shipping damage is not covered by warranty. If shipping damage is found, notify carrier at once. The carrier is responsible for all repair and replacement costs resulting from damage in shipment.

The pump can be ordered either with or without batteries and a compatible AC-powered battery charger. These items will be included in the shipment if ordered.

5.2 Hydraulic Connections

WARNING All hydraulic hoses and fittings used with the pump must be rated for 10,150 psi [700] bar working pressure. Failure to observe and comply could result in death or serious personal injury. Property damage could also occur.

Make hydraulic connections as described in the following steps. The pump is equipped with Enerpac Spin-On coupler halves pre-installed in the pump “A” and “B” ports. Couplers must be polarized as shown in Figure 2 to ensure correct wrench operation.

1. To prevent the pump from starting while hydraulic connections are being made, be sure that the pump power switch is turned off (○). Or, remove the battery from the pump (if installed).
2. Check the pump hydraulic pressure gauge. If any pressure is indicated, loosen the relief valve locknut and turn the pressure adjustment knob counter-clockwise until pressure is relieved and gauge indicates zero (0) psi/bar. Refer to Figure 9.
3. Remove dust caps from couplers at ports “A” and “B” of the pump.
4. Connect the hose from the advance side of the torque wrench to port “A” of the pump.
5. Connect the hose from the retract side of the torque wrench to port “B” of the pump.

WARNING Be certain that all hose couplers are fully engaged at both the pump and wrench ends before applying any hydraulic pressure. If the couplers are not fully engaged, oil flow will be blocked, and the torque wrench drive unit could be subjected to excessive hydraulic pressures. Oil leakage and/or catastrophic failure of wrench or pump may occur. Skin penetration by hydraulic oil and other serious personal injuries could result.

NOTICE

- The Spin-on couplers used on Enerpac THQ Series torque wrench hoses (optional accessory - sold separately) are compatible with the Spin-on couplers pre-installed on the pump. Use of THQ Series hoses is strongly recommended.
- At each connection, rotate the threaded collar of the female coupler half by hand, until it is fully threaded onto the male coupler half. Hand tighten only. Do not use tools.
- When a torque wrench is first connected to the pump, air will be trapped in the hydraulic circuit. Refer to Section 7.10 for air removal procedure.

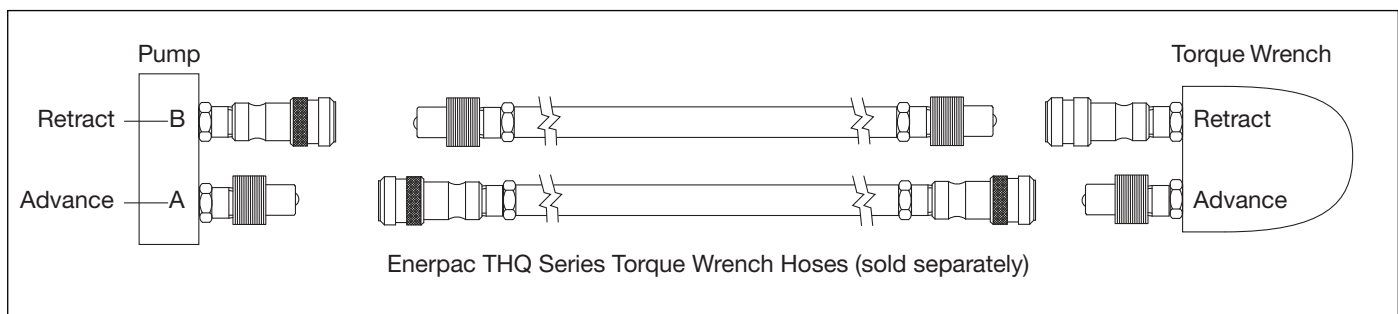

Figure 2: Hydraulic Hose Connections

NOTICE If using threaded hydraulic fittings instead of quick-disconnect couplers, be sure that all connections are securely tightened and leak free. Use 1.5 wraps of PTFE sealing tape (or suitable thread sealant) on all threads, leaving the first complete thread free of tape to be sure no foreign matter enters the hydraulic circuit.

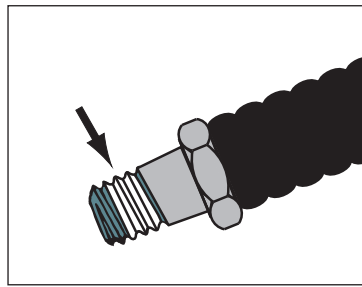

Figure 3: Sealing Tape

5.3 Connecting the Remote Pendant

1. Remove the dust cap from the connector at the front of the pump and connect the pendant cable. See Figure 4.
2. Hand tighten the threaded collar to secure the pendant cable to the connector.

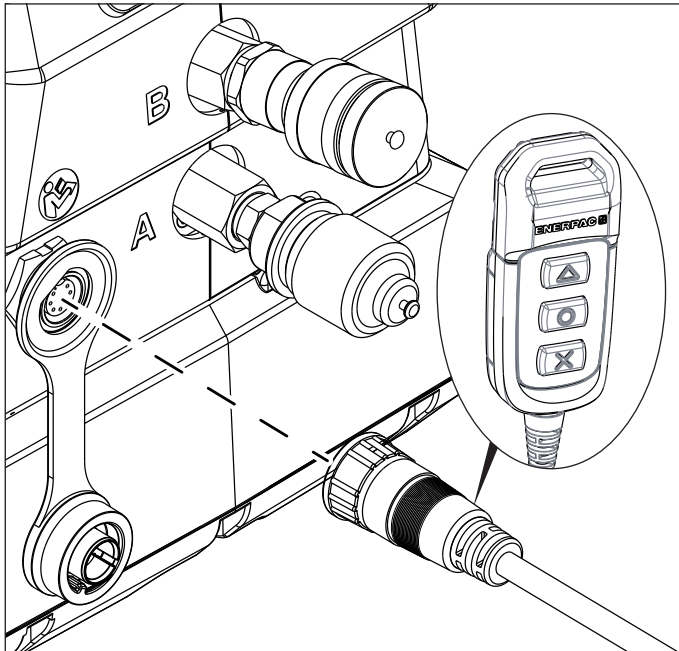

Figure 4: Remote Pendant Connection

6.0 BATTERY

NOTICE Press battery charge indicator button to determine charge level before using or charging battery for the first time.

NOTICE New batteries should be fully charged before use. Battery and charger must be purchased separately if not included in the shipment with the pump. Refer to Section 3.5 of this manual for battery and charger model numbers.

NOTICE Refer to the separate battery and charger manuals for complete battery use and care information and charging instructions.

6.1 Charge Level Indicator

A small panel containing a charge indicator button and four charge indicator lights is located on the battery housing. Press the button to display the battery charge level. The lights will remain on for 3 seconds and then turn off automatically. See Figure 5.

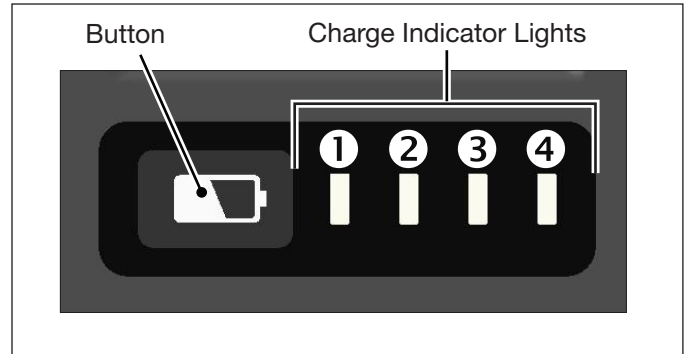







Figure 5: Battery Charge Level Indicator

Refer to the following table to determine the level of charge:

	When battery charge indicator button is pressed:	Percent Charge: (approximate)
Lights 1-4 on		Above 75%
Lights 1-3 on		51 - 75%
Lights 1-2 on		26 - 50%
Light 1 on		10 - 25%
Light 1 flashing red	 Remaining Charge < 5%	

One or more of the indicator lights should glow white when the battery charge indicator button is pressed. If the #1 indicator light flashes red when the button is pressed, the battery charge is very low. If none of the lights illuminate when the button is pressed, the battery is fully discharged.

NOTICE Run time between battery charges is mostly dependent on the pressure required for the application. The higher the required pressure setting, the shorter the runtime will be. To increase runtime, whenever possible use a torque wrench capable of providing the desired torque at a setting of below 8,000 psi [552 bar].

6.2 Low Voltage Shutoff

The pump will stop running (or will be prevented from starting) if battery voltage drops below a pre-determined low limit.

The pump may slow down or operate sluggishly before shutoff occurs, providing a signal that the battery is approaching full discharge.

NOTICE It is recommended that the battery be removed from the pump and placed in the charger before it becomes fully discharged. Full discharge cycles may cause permanent damage to the battery cells.

NOTICE If the battery becomes fully discharged while the pump is in use, it should be placed in the charger within 12 hours and kept in the charger until fully charged. This will help prevent battery damage and premature battery failure.

6.3 Overcurrent and Overtemperature Protection

The battery will shut-off automatically in the event that battery current draw becomes excessive or if the battery's internal temperature rises above acceptable limits.

Both faults are self-resetting. Normal battery operation will resume when the excessive current draw condition is eliminated or after the battery has cooled down.

In order to reset these faults, it may sometimes be necessary to cycle the pump power switch off and on, or to remove and reinstall the battery.

6.4 Cold Weather Operation

If the battery's internal temperature drops below approximately -13°F [-25°C], battery shutdown will occur and the pump will be prevented from starting.

If the pump will not start and the ambient temperature is very cold, remove the battery from the pump and take it to a room temperature location. Allow time for the battery to warm-up and be sure it is fully charged. Then, re-install the battery and try starting the pump again.

6.5 Battery Installation and Removal

- **To install battery on pump:** Slide the battery down onto the battery interface at the rear of the pump. Make sure it latches securely into place. See Figure 6.
- **To remove battery from pump:** Press and hold the release buttons located on each side of the battery. Then, slide the battery upward and remove it from the pump. See Figure 7.

NOTICE To ensure compatibility and proper operation, use only the specified Enerpac 54V Lithium-Ion battery with the pump. Refer to Section 3.5 for battery specifications and model number.

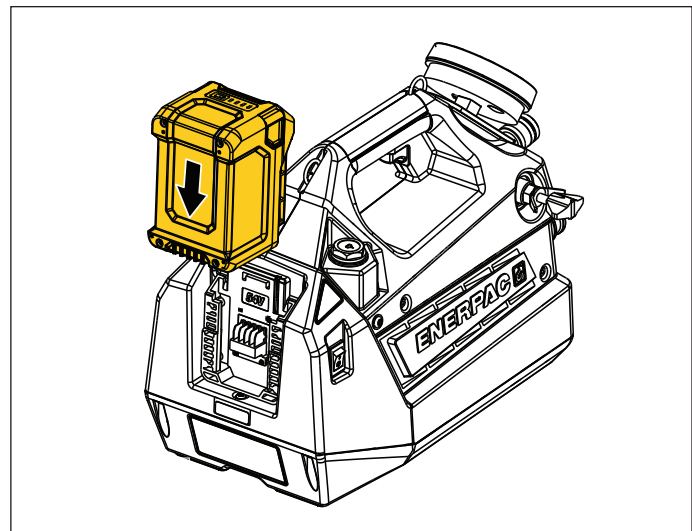

Figure 6: Battery - Install

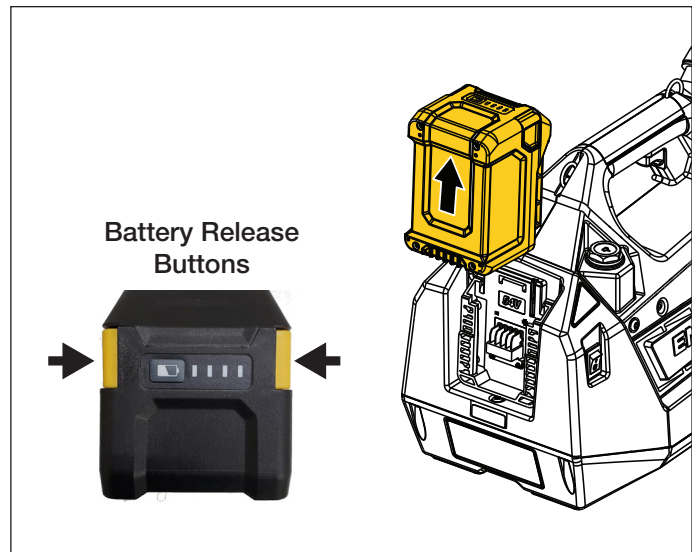

Figure 7: Battery - Remove

7.0 OPERATION

7.1 Power Switch

The pump is equipped with a two-position rocker style power switch. It is located on the right-hand side of the pump housing near the battery. Refer to Figure 8.

Depressing the top half of the power switch (I) connects battery power to the pump motor control circuit. Depressing the bottom half of the power switch (O) disconnects battery power to the motor control circuit.

The power switch must be in the ON (I) position to allow the pump motor to start, whether it is being controlled by the pump's built-in trigger or the optional remote pendant. The trigger switch and pendant buttons are non-functional when the power switch is in the OFF (O) position.

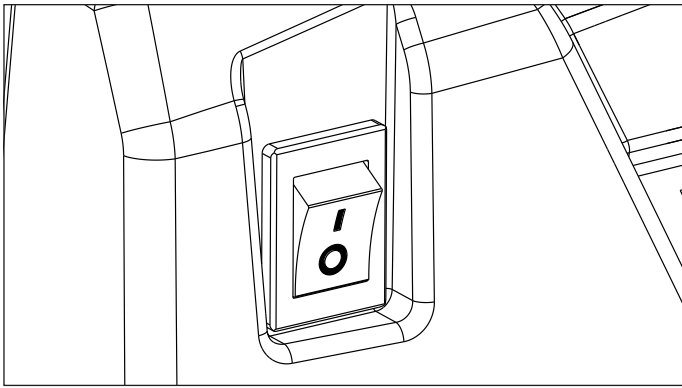

Figure 8: Power Switch

The power switch can remain in the ON (I) position when the pump is temporarily idle, but in regular use.

However, always turn the power switch OFF (O) in any of the following conditions:

- If an emergency occurs and the pump must be stopped immediately.
- Before moving or transporting the pump.
- During sustained periods of non-use (overnight, etc.) while the battery remains installed on the pump.
- When performing routine inspection and maintenance procedures while the battery is installed.

NOTICE The pump motor control circuits will consume a small amount of battery power when the pump is idle and the power switch is in the ON (I) position. To prolong the battery charge, it is recommended that the power switch be turned off overnight and during other long periods of inactivity.

7.2 Before Start-up

1. Connect the advance and retract hydraulic hoses. Check all hydraulic fittings and connections to be sure they are tight and leak free. Refer to instructions in Section 5.2.
2. Check the hydraulic oil level. Add oil if necessary. Refer to sections 8.1, 8.2 and 8.3 for procedures.
3. Connect the remote pendant to the pendant connector located on the front of the pump. Refer to instructions in Section 5.3.
4. If ordered with the pump: Attach the shoulder strap (optional accessory) to the ring at each end of the pump carrying handle.
5. Install a fully charged battery on the pump. Refer to Section 6.5 for additional information.

NOTICE Press battery charge indicator button to determine charge level before using or charging battery for the first time.

NOTICE New batteries should be fully charged before use. Refer to Section 6.1. Also refer to the separate manuals for the battery and battery charger for additional information.

6. Before operating the pump under load, perform the air removal procedure to purge any trapped air from the system. Refer to Section 7.10.
7. Set relief valve pressure to the setting that corresponds to the desired target torque for your application. Refer to instructions in Section 7.3.

7.3 Relief Valve Pressure (torque) Adjustment

The pump contains a user-adjustable hydraulic pressure relief valve which allows the pump to be set to a specific target pressure corresponding to the desired target torque required for your application. See Figure 9.

WARNING Always check relieve valve pressure setting BEFORE placing torque wrench on nut or bolt head. It is possible that the current relief valve pressure setting is set above the pressure needed to provide the required torque for your application. Exceeding the required torque may result in serious personal injury and could cause equipment damage.

Set the relief valve pressure as described in the following steps. Refer to Section 7.5 for remote pendant operation details.

1. Be sure that the torque wrench is removed from the fastener. Hoses and torque wrench can remain connected.
2. Refer to torque wrench manufacturer's instructions for the amount of hydraulic pressure required to produce the desired target torque. Note that maximum pressure varies for different wrenches and accessories.
3. Loosen locknut and back-out relief valve knob several turns to prevent unintended pressure build-up.
4. Turn on the pump power switch (I).

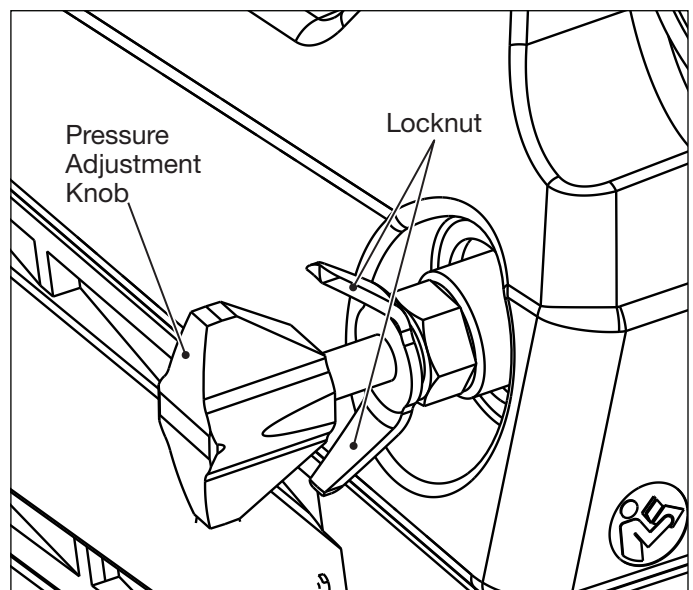



Figure 9: Relief Valve Pressure (torque) Adjustment

5. Press and hold the pendant ON-ADVANCE button  to start the motor and build pressure.
6. With the motor running, check the pump pressure gauge reading to determine the current relief valve pressure setting.

NOTICE If the setting requires readjustment, follow the instructions in step 7. If the setting is correct for your application, skip step 7 and go to step 8. Maximum system pressure is limited to approximately 10,400-10,800 psi [717 - 744 bar] by an internal safety relief valve.

7. While continuing to press and hold the pendant ON-ADVANCE button, turn the adjustment knob inward (clockwise) to increase pressure or outward (counter-clockwise) to decrease pressure. Adjust as required until the desired pressure setting is shown on the pressure gauge.

NOTICE The ON-ADVANCE button  must be released and pressed again to verify the pressure setting when the setting is being decreased.

WARNING Be certain that the pressure setting does not exceed the maximum rated pressure of the torque wrench to be used, or of any other components in the system (hoses, fittings, etc.). Failure to observe this precaution may result in failure of wrench and related components. Death or serious personal injury could occur.

8. Hand tighten the locknut on the relief valve to maintain the pressure setting.
9. Restart the pump and recheck the pressure setting. Do this several times to verify that the setting is correct.

7.4 Operating Precautions

NOTICE

- Be sure the nut or bolt to be fastened is clean and free of loose dust or dirt.
- Be sure that fastener threads are properly engaged with each other, and that cross-threading has not occurred.
- Be sure that threads and the bearing surface are liberally coated with the correct bolt lubricant or anti-seize compound.
- Make all torque calculations based on the bolt lubricant's (or anti-seize compound's) stated coefficient of friction. Failure to do so may result in the required bolt load not being achieved.

WARNING Failure to observe and comply with the following precautions could result in death or serious personal injury. Property damage could also occur.

- Check that all hydraulic coupler halves are fully engaged before operating pump. Partial coupler engagement will prevent proper wrench operation and could result in a safety hazard (refer to warning statement in Section 5.2).

- Avoid making sudden start-stop movements (“shock loading”) during bolting procedures. Failure to observe this precaution may cause a catastrophic failure of the wrench to occur, and wrench components under high tension could become dangerous projectiles.
- If the torque wrench stalls at any time, release the pendant ON-ADVANCE button  to stop the advance process.
- Continuously monitor the torque wrench and fastener while torquing is in progress. Stop torquing procedures immediately if any problems occur.
- Refer to the manufacturer’s manuals provided with the torque wrench for wrench operation instructions, maintenance procedures and safety precautions.





7.5 Remote Pendant Operation



The pump motor and solenoid operated control valve are operated by a corded remote pendant which is included with the pump.



When possible, a single user should operate the torque wrench and pump. This can prevent accidental activation of the pump while another person is positioning the wrench.

Before using the pendant, be sure the pump power switch is in the ON (I) position and that battery is charged.

Pendant operation is as follows. See Figure 10:

- Press and hold the ON-ADVANCE button  to start the motor and advance the torque wrench. The pressure gauge will display the pressure in the advance circuit.
- Release the ON-ADVANCE button  to retract the torque wrench. The pressure gauge will display the pressure in the retract circuit and the motor will continue running.
- Press and hold the ON-ADVANCE button  at any time while the motor is running to repeat torque wrench advance.
- Press either MOTOR OFF button  or  to stop the motor and relieve hydraulic pressure.
- If the motor runs for 20 seconds without any pendant buttons being pressed, automatic motor stop will occur and hydraulic pressure will be relieved.

NOTICE The MOTOR OFF buttons  and  function in an identical manner. Either button can be used to stop the motor and relieve pressure. To avoid triggering a pump fault condition, press only one MOTOR OFF button at a time, not both.

NOTICE When either MOTOR OFF button  or  is pressed, the shutdown/pressure relief sequence will continue for about 5 seconds. The pump will not respond to any pendant button commands until this sequence is completed.

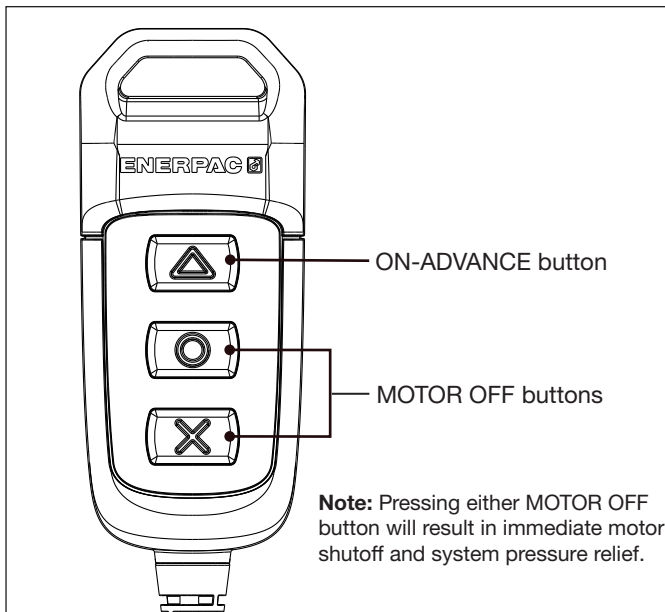







Figure 10: Remote Pendant

7.6 Torquing Procedure (Typical)

1. Set relief valve pressure to the setting that corresponds to the desired target torque for your application. Refer to instructions in Section 7.3.
2. Place torque wrench on nut or bolt.

⚠ WARNING In the following step, the pump motor will start and the valve will shift automatically, advancing the torque wrench. Verify that torque wrench is positioned to avoid injury or equipment damage before starting motor.

3. Press and hold the ON-ADVANCE button to start the motor and advance the wrench.
4. Release the ON-ADVANCE button  to retract the wrench.
5. Press and hold the ON-ADVANCE button  again to advance the wrench.
6. Repeat steps 3 through 5 as needed until the desired target torque is reached. Use the pump pressure gauge as a guide.

NOTICE When the ON-ADVANCE button  is released, the motor will shut-off after 20 seconds and pressure will automatically be relieved. To stop the motor sooner, press and release the MOTOR OFF button  or .

7.7 Trigger Switch Operation

The trigger switch is provided as an alternate way to operate the pump. It can be used to temporarily operate the pump in the event that the remote pendant is missing or damaged. It can also be used when working in confined spaces, where using the pendant may be difficult or inconvenient.

Operate the trigger switch as follows. See Figure 11:

1. Be sure that the pump power switch is in the ON (I) position.

⚠ WARNING In the following step, the pump motor will start and the valve will shift automatically, advancing the torque wrench. Verify that torque wrench is positioned to avoid injury or equipment damage before starting motor.

2. To start the motor and advance the torque wrench, firmly grasp the carrying handle and pull the trigger switch fully upward.
3. To retract the torque wrench, fully release the trigger switch. The motor will continue running. However, if the trigger switch is not pulled again within 20 seconds, the motor will stop and hydraulic pressure will automatically be relieved (automatic time delay shutoff).

Unlike the remote pendant, the trigger switch does not allow the pump motor to be stopped immediately. If an immediate stop is necessary, turn off the pump power switch (O).

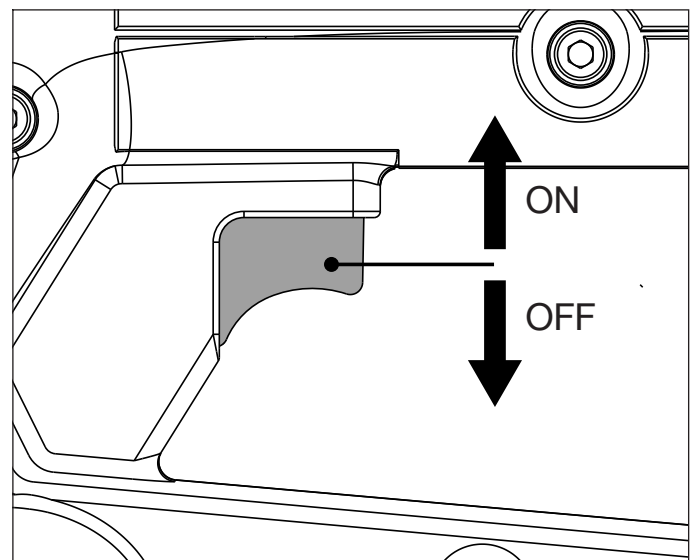



Figure 11: Trigger Switch

7.8 Fault Conditions

If a fault condition is initiated while the pump motor is running, the motor will stop immediately. In addition, when a fault condition is active, the motor will not restart when the pendant ON-ADVANCE button  is pressed or when the pump trigger switch is pulled upward.

Any of the following occurrences will initiate a fault condition:

- Pressing any two pendant buttons at the same time.
- Pressing any pendant button at the same time while the pump trigger switch is being operated.
- If battery voltage falls below a pre-determined limit.
- Excessive pump internal temperatures.
- Damaged pump components and/or abnormal conditions sensed by the pump electronic control system.

7.9 If Motor Fails To Start (Fault Reset)

If the battery is charged, and the pump motor fails to start when the pendant ON-ADVANCE button  is pressed:

1. Turn off the pump power switch (O).
2. Wait for 3 to 5 seconds. Then, turn on the pump power switch to reset the fault.
3. If the fault has been successfully reset and the battery is adequately charged, normal pump operation should resume.

NOTICE If the motor still fails to start, take the pump to an Enerpac authorized service center for inspection and diagnosis.

7.10 Air Removal



When hydraulic connections are made to a new pump, air will be trapped inside the hoses and other components. This trapped air can cause erratic torque wrench operation.

To ensure smooth, safe operation, remove the pump oil fill plug and run the torque wrench through several complete advance and pressure release cycles. Do this under no load and with the pump positioned higher than the wrench.

When the torque wrench advances and retracts smoothly without hesitation, it is an indication that air has been successfully vented from the system. Re-install the oil fill plug after procedure is completed.

7.11 Disconnecting Hydraulic Hoses

Relieve hydraulic pressure and disconnect the hydraulic hoses from the pump as described in the following steps:

1. Be sure that the torque wrench is removed from nut or bolt.
2. With the power switch in the ON (I) position, press the pendant MOTOR OFF button  or  to relieve any residual hydraulic pressure in the system.

NOTICE If battery is fully discharged, or if pressure relief function is not working, relieve trapped pressure manually by turning pump relief valve knob counter-clockwise until pressure is relieved. Refer to Figure 9.

3. Check the pump pressure gauge. Verify that the gauge indicates zero (0) psi/bar. Verify that hoses are not stiff and that there are no other indications of possible trapped hydraulic pressure.
4. Turn off the pump power switch (O).
5. Disconnect hoses from hydraulic couplers at ports "A" and "B" of pump.
6. To prevent dirt entry and contamination, install dust caps on the hydraulic couplers.

7.12 Transporting the Pump



Before moving or transporting the pump, be sure that the pump power switch is OFF (O) or that the battery is removed. This will help prevent accidental pump startup.

Always move or transport the pump using either the built-in carrying handle or the shoulder strap (optional accessory).

NOTICE Never attempt to transport or reposition the pump by lifting or dragging it by the hoses. Damage to the pump and/or hoses may result.

8.0 MAINTENANCE

8.1 Check Oil Level

1. With the pump power switch in the ON (I) position, press the pendant MOTOR OFF button  or  to relieve any residual hydraulic pressure in the system.
2. Turn off the pump power switch (O).
3. Be sure the pump is on a level surface.
4. Remove the oil fill plug from the fill opening. Use a 27 mm wrench. See Figure 12.
5. Check the oil level. Reservoir is FULL when oil level is near the top of the oil fill tube.
6. If oil level is low, add oil as described in Section 8.3. Refer to Section 8.2 for oil requirements.

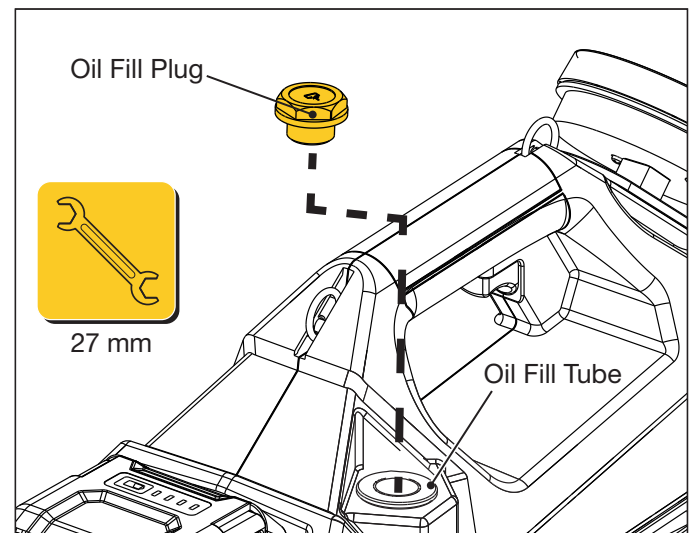

Figure 12: Oil Fill Location

NOTICE An O-ring fits inside a groove on the underside of the oil fill plug. Check for this O-ring and reinstall it if it has dropped out of the groove. If the O-ring is missing or damaged, replace the oil fill plug. A new O-ring will be included with the replacement oil fill plug.

7. Reinstall the oil fill plug after checking oil level. Tighten the plug until it is hand-tight. Do not overtighten.

8.2 Hydraulic Oil Requirements

Use only Enerpac HF hydraulic oil when adding additional oil or when performing an oil change. Enerpac HF hydraulic oil is available from Enerpac distributors and Enerpac authorized service centers.

NOTICE Use only Enerpac HF hydraulic oil. Use of other oils may result in damage to pump components. Such damage is not covered under the Enerpac product warranty.



8.3 Adding Oil

CAUTION Be certain that the torque wrench is fully retracted before adding any oil to the hydraulic reservoir. If oil is added while the torque wrench is fully or partially advanced, the reservoir could become overfilled and burst when the torque wrench is retracted. Oil leakage and possible personal injury could occur.

NOTICE

- Always turn off the pump power switch (O) before removing the oil fill plug and adding oil. This will prevent accidental pump start-up.
- Use only Enerpac HF hydraulic oil. Refer to Section 8.2. Use only new oil poured from a clean container.
- To avoid spillage and to allow proper venting, always use a funnel of the proper size when adding oil. Spillage and under filling will occur if a funnel is not used.

Add oil as described in the following steps:

1. With the power switch turned on (I), press the MOTOR OFF button  or  to relieve any residual hydraulic pressure.
2. Place the pump on a level work surface. Be sure the pump power switch is in the OFF (O) position.
3. Remove the oil fill plug from the fill opening. Use a 27 mm wrench. See Figure 12.
4. Place a funnel (maximum 3/4" [19 mm] stem outer diameter & at least 1-3/16" [30 mm] long) through the fill opening and insert it into the oil fill tube. See Figure 13.

NOTICE Pour oil slowly to avoid spillage. If oil begins to overflow from the fill opening, stop pouring immediately.

5. SLOWLY add Enerpac HF oil while watching the oil level in the funnel stem. To avoid spillage, stop pouring immediately when oil reaches the top of the fill opening or begins flowing around the outside of the funnel stem.
6. Remove funnel from the fill opening. Wipe off and/or remove any spilled oil.

NOTICE Dispose of spilled oil in accordance with all applicable laws and regulations.

NOTICE An O-ring fits inside a groove on the underside of the oil fill plug. Check for this O-ring and reinstall it if it has dropped out of the groove. If the O-ring is missing or damaged, replace the oil fill plug. A new O-ring will be included with the replacement oil fill plug.

7. Reinstall the oil fill plug. Tighten the plug until it is hand-tight. Do not over-tighten.

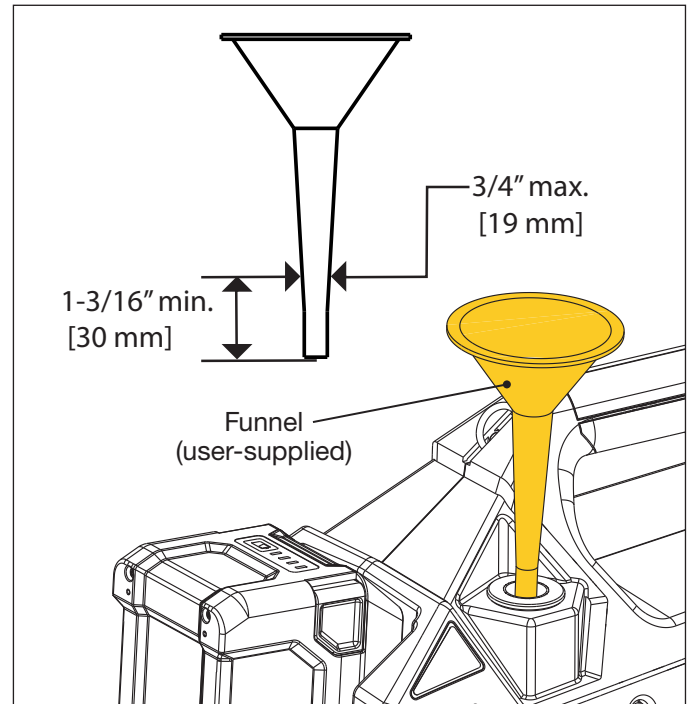

Figure 13: Adding Oil Using Funnel

8.4 Oil Change

Check oil for contamination by comparing the color of the oil in the reservoir fill tube to new unused Enerpac HF oil. Unused Enerpac HF oil is a crisp blue color.

As a general rule, completely drain and refill the pump's bladder type reservoir every 250 hours of operation, or more frequently if used in dirty environments. Refer to the following procedure:

1. Relieve any residual hydraulic pressure and disconnect hydraulic hoses from the pump "A" and "B" ports. Refer to instructions in Section 7.11 of this manual.
2. Place the pump on a level work surface. Be sure the pump power switch is in the OFF (O) position.
3. Attach an open-ended hose to the pump "A" port. Place the open end of the hose in a suitable pan or container that is large enough to collect all the used oil. See Figure 14.

NOTICE Model XC2502B has a two liter [120 in³] reservoir capacity. Model XC2504B has a four liter [240 in³] reservoir capacity. Be sure that pan or container is large enough to hold all the used oil.

4. Install a dust cap on the "B" port hydraulic coupler. If not using couplers, seal the "B" port with a 1/4" NPTF metal plug.
5. If removed, reinstall the oil fill plug in the pump oil fill port. This plug must remain installed in steps 6-8.
6. Turn on the pump power switch (I).

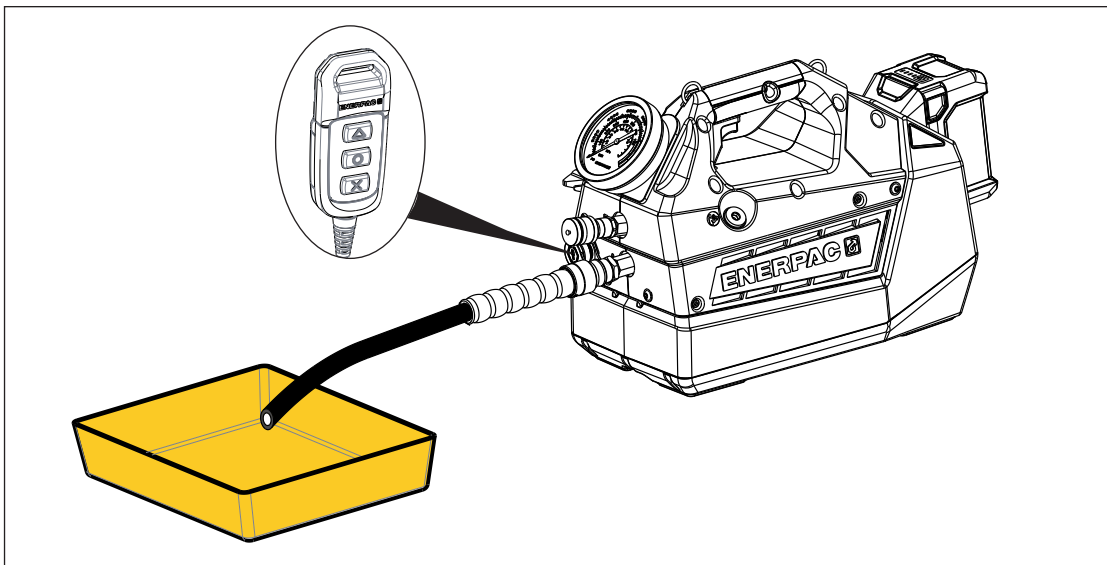





Figure 14: Draining the Hydraulic Reservoir

7. Press and hold the ON-ADVANCE button  to start the motor and begin draining the reservoir. Continue running the motor until oil stops flowing from the open-ended hose. Then, press the MOTOR OFF button  or  to stop the motor.

NOTICE Dispose of used oil in accordance with all applicable laws and regulations.

8. Turn off the pump power switch (●).
9. Remove the oil fill plug and fill the reservoir with new Enerpac oil. Refer to Section 8.2 for hydraulic oil requirements and Section 8.3 for detailed oil fill instructions.

NOTICE The actual amount of oil required to fill a completely empty reservoir may be slightly more than the pump's rated usable oil capacity (Refer to Section 3.4 of this manual).

10. Disconnect the open-ended hose from the pump "A" port. Reconnect the torque wrench advance hose.
11. Remove the dust cap from the "B" port hydraulic coupler. If a coupler is not being used, remove the metal plug from the pump "B" port. Reconnect the torque wrench retract hose.
12. Run the pump and cycle the torque wrench (while not mounted on nut or bolt) several times to bleed any trapped air from the system. Refer to Section 7.10 for additional information.
13. Recheck oil level after cycling the torque wrench. Verify that oil level has not dropped. Add additional oil if level is low.

9.0 CLEANING

- Before beginning any cleaning procedures, always turn off the pump power switch (●) or remove the battery. Be sure that hydraulic pressure is completely relieved (0 psi/bar).
- Motor cooling vents are located on both sides of the pump housing, around each ENERPAC logo. To help ensure unrestricted airflow, remove any dust or dirt from these vents. Use a suitable soft brush.

WARNING To avoid a shock hazard, do not insert any objects inside the vents. Do not spray water or cleaners inside the vents.

- Wipe the pump exterior with a dry, soft cloth. Avoid using strong detergents or cleaners.
- Refer to the battery manual for battery cleaning instructions.

10.0 STORAGE

Store the pump as described in the following procedure:

1. Be sure that hydraulic pressure is completely relieved (0 psi/bar).
2. Turn off the pump power switch (●).
3. Remove the battery from the pump.
4. Store the pump and battery in a clean, dry and secured location, away from unauthorized users. Avoid storing in extreme heat or cold.

NOTICE After removing battery from storage, press charge indicator button to determine battery charge level. Do this before using or charging battery.

NOTICE Refer to the separate manuals for the battery and battery charger for additional storage information pertaining to those items.

11.0 SAFE DISPOSAL PROCEDURE

When the pump has reached the end of its useful life, dispose of it as described in the following steps:

1. Drain all hydraulic oil from the pump hydraulic reservoir as described in Section 8.4 of this manual. Dispose of used oil in accordance with all applicable laws and regulations.
2. Remove battery from pump. Dispose of battery in accordance with instructions contained in the Enerpac battery manual.
3. Take the pump to an approved industrial recycling facility for disposal

12.0 FIRMWARE UPDATES

When issued, product firmware updates will be made available via the Enerpac Connect App. Specific firmware updating instructions for your product model will be provided in the app.



The Enerpac Connect App is available for download on the Apple App Store and on Google Play.



Google Play and the Google Play logo are trademarks of Google LLC. App Store is a trademark of Apple Inc., registered in the U.S. and other countries and regions.

13.0 TROUBLESHOOTING

Only qualified technicians should service the pump or system components. For repair service, contact your Enerpac authorized service center.

The troubleshooting guide (see next page) is intended to be used only as an aid in determining if a problem exists. A system failure may or may not be the result of a pump malfunction. To determine the cause of the problem, the complete system must be included in any diagnostic procedure.

⚠ WARNING Failure to observe and comply with the following precautions could result in death or serious personal injury. Property damage could also occur.

- Never tighten or loosen hydraulic fittings while the pump hydraulic system or connected components are pressurized. Escaping oil under pressure can penetrate the skin, causing serious personal injury.
- Keep hands, fingers and other body parts clear of pinch points and moving parts when observing operation during troubleshooting.
- To prevent accidental start-up of pump during servicing, always remove battery from pump before performing any repair procedures.

Troubleshooting Guide		
Problem	Possible Cause	Action
1. Pump will not start.	a. Battery not installed.	Install battery.
	b. Pump power switch is in the OFF (O) position.	Turn on the pump power switch (I).
	c. Battery discharged.	Press the battery charge indicator button to determine battery charge level. Place battery in charger if charge level is low. Replace battery if it is damaged and cannot be charged.
	d. Electrical contacts dirty or corroded.	Clean the pump electrical contacts. ⚠ WARNING To avoid sparks or possible electric shock, DO NOT clean contacts on battery.
	e. Battery overtemperature or undertemperature condition.	Battery will shut-down and prevent pump from starting if its internal temperature becomes too high or too low. If this condition is suspected, remove the battery from the pump and take it to a room temperature location. Allow time for the battery to return to normal operating temperatures before reinstalling it on the pump.
	f. Fault Condition. <ul style="list-style-type: none"> • Button Fault • Trigger Fault • Other Fault Condition 	Cycle pump power switch off and on to reset fault condition. Or, remove and reinstall battery.
	g. Pendant controls or cable damaged.	Try operating the pump using the trigger switch or a different compatible pendant. If pump starts and operates normally, repair or replace the pendant.
	h. Motor and/or electronic control board damaged.	Contact Enerpac authorized service center.
	i. Pump jammed due to obstruction. Possible internal damage to pump.	Contact Enerpac authorized service center.

(continued on next page)

Troubleshooting Guide (continued)

Problem	Possible Cause	Action
2. Low fluid output.	a. Pump needs priming.	To prime the pump, be sure that the pump reservoir is filled with oil. Then, run the pump in retract mode while gently rocking the pump from side-to-side.
	b. Bypass valve malfunction.	Contact Enerpac authorized service center.
	c. Oil intake screen clogged with debris.	Contact Enerpac authorized service center.
	d. Control valve internal leakage, wear and/or damage.	Contact Enerpac authorized service center.
	e. Pump element internal leakage, wear and/or damage.	Contact Enerpac authorized service center.
3. Wrench will not advance or retract.	a. Hydraulic coupler(s) not fully engaged.	Check hydraulic couplers for full engagement. A partially engaged hydraulic coupler may reduce or block hydraulic flow.
	b. Low oil level.	Add oil until reservoir is completely full.
	c. Pump needs priming.	To prime the pump, be sure that the pump reservoir is filled with oil. Then, run the pump in retract mode while gently rocking the pump from side-to-side.
	d. Solenoid coil will not energize to shift valve.	Replace solenoid coil. Contact Enerpac authorized service center.
	e. Oil intake screen clogged with debris.	Contact Enerpac authorized service center.
4. Wrench advances and retracts erratically.	a. Air in the system.	Advance and retract the wrench until operation is smooth. Refer to procedure in Section 7.10.
	b. External hydraulic leak.	Tighten connections. Replace damaged components.
	c. Control valve internal leakage, wear and/or damage.	Contact Enerpac authorized service center.
	d. Pump element internal leakage, wear and/or damage.	Contact Enerpac authorized service center.

(continued on next page)

Troubleshooting Guide (continued)

Problem	Possible Cause	Action
5. Pump slows down and stops.	Battery discharged.	Charge battery. Replace battery if it is damaged and cannot be charged.
6. Pump stops during prolonged or heavy operation.	Excessive current draw or overtemperature condition.	Immediately release the trigger switch or pendant ON-ADVANCE button  . Allow time for pump to cool before restarting.
7. Pump stops during normal operation (even when battery is sufficiently charged).	a. Electromagnetic interference (EMI).	<p>Electromagnetic interference (EMI) from other devices may cause pump to stop running and become unresponsive. When an EMI related shutdown occurs, the pump electronics will automatically reset and must finish cycling before the pump can be restarted.</p> <p>If pump stops after being restarted, check for and remove source of electromagnetic interference. If this is not possible, try repositioning or relocating the pump. Refer to Section 2.2 of this manual for additional information.</p>
	b. Mechanical or electrical component failure.	Contact Enerpac authorized service center.
8. Pump does not build pressure.	User-adjustable relief valve set too low.	Adjust relief valve pressure. Refer to procedure in Section 7.3.
9. Noisy pump operation.	a. Pump element piston sticking.	Contact Enerpac authorized service center.
	b. Motor or gear damaged.	Contact Enerpac authorized service center.

14.0 REPAIR PARTS SECTION

CONTENTS	PAGE
FIGURE 15: MAIN ASSEMBLY	24
FIGURE 16: SHROUD HALVES & PENDANT.....	26
FIGURE 17: RIGHT-HAND SHROUD COMPONENTS	28
FIGURE 18: PUMP BASE ASSEMBLY	30
FIGURE 19: POWER UNIT & RESERVOIR ASSEMBLY	32
FIGURE 20: POWER UNIT & RESERVOIR ASSEMBLY (REPEATED VIEW)	34
FIGURE 21: CONTROL VALVE ASSEMBLY, VIEW 1 OF 2	36
FIGURE 22: CONTROL VALVE ASSEMBLY, VIEW 2 OF 2	38
FIGURE 23: ECCENTRIC SHAFT & HOUSING SUBASSEMBLY	40
FIGURE 24: ECCENTRIC SHAFT ASSEMBLY	42
FIGURE 25: PUMP ELEMENT	42
FIGURE 26: PUMP ELEMENT COMPONENTS	44
FIGURE 27: BATTERY AND BATTERY CHARGER	46
FIGURE 28: SELECTED ACCESSORIES	46
FIGURE 29: HYDRAULIC SCHEMATIC	48
FIGURE 30: ELECTRICAL SCHEMATIC	49

Parts List for Figure 15

Item	Description	Qty	Part Number	
			Model XC2502B	Model XC2504B
3	◆ Screw, SHCS Hex, M5	2	CBZ517028-1A	CBZ517028-1A
4	❖ Pin, 6 mm x 45 mm Lg	2	DD3417059	DD3417059
6	□ Cable Tie, Screw Mount	1	DD7326217	DD7326217
7	Gauge, Hydraulic Pressure	1	DD7397223SR	DD7397223SR
10	◆ Grommet	1	DD7973808	DD7973808
11	† Tube, 0.38 OD x 2.56 Lg	1	DD8428268	DD8428268
12	▲▼† Fitting, Elbow 45 Tube to Barb	1	DD8498097	DD8498097
13	Pump Base Assembly	1	(See Figure 18)	(See Figure 18)
14	Power Unit & Reservoir Assembly	1	(See Figure 19)	(See Figure 19)
17	Decal, Prod Specification Nameplate	1	DD8793026SR	DD8794026SR
18	○ Decal, 54V Right	1	DD8925026	DD8925026
19	○ Decal, 54V Left	1	DD8924026	DD8924026
20	○ Decal, California Prop 65	1	DD9065026	DD9065026
21	▲▼† Clamp, Pinch	1	DD9124299	DD9124299
22	○ Nut, Clip On M6	4	DD9397021	DD9397021
23	◆ Screw, Flange Button Head M6	2	DD9398048	DD9398048
24A	Motor Driver, 24-63 VDC	1	DD8815380SR	DD8815380SR
24B	□ Bracket, Motor Clamp	1	DD8248111	DD8248111
24C	□ Standoff, 6 mm Hex	3	DD9404054	DD9404054
24D	□ SHCS, Hex, M4	6	CBE413028-1A	CBE413028-1A
24E	Ferrite Core	1	DM1535380SR	DM1535380SR
25	Insert, Foam	2	DD9045225	- - -
▲ Items included in 2L Bladder Kit, XC2B2LK.				
▼ Items included in 4L Bladder Kit, XC2B4LK.				
○ Items included in Lower Shroud Kit, XC2LSK.				
◆ Items included in Upper Shroud Kit, XC2USK.				
❖ Items included in Eccentric Housing Service Kit, XC2ECK.				
□ Items included in Motor Driver Mounting Kit, XC2MDMK.				
† Items included in Oil Fill Tube Kit, XC2TK.				

Figure 16: Shroud Halves & Pendant

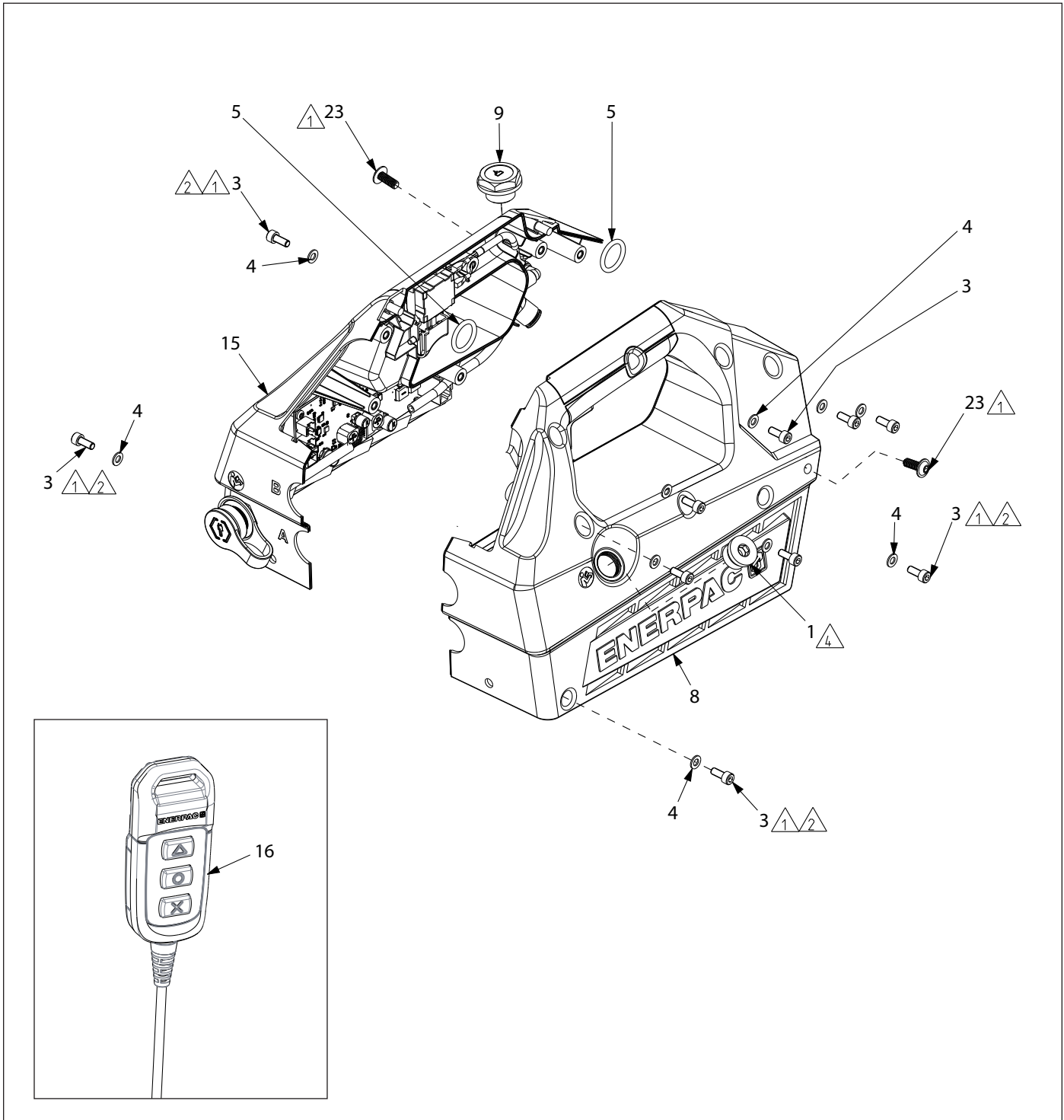

Notes:

- ⚠ Torque to 18-26 in-lbs [2 - 3 Nm].
- ⚠ Secure with Loctite 243 thread locking compound.
Refer to manufacturer's technical data sheet for application instructions.
- ⚠ Torque to 25-30 in-lbs [2.8 - 3.4 Nm].
- ⚠ Item 16 is supplied with all XC2500 Series pumps as standard equipment.

Parts List for Figure 16

Item	Description	Qty	Part Number	
			Model XC2502B	Model XC2504B
1	◆ Plug, Soc Hd St Thread 0.750-16	1	B1006006	B1006006
3	◆ Screw, SHCS Hex, M5	10	CBZ517028-1A	CBZ517028-1A
4	◆ Washer, Flat	10	CAE1050108-1A	CAE1050108-1A
5	Ring, Round	2	DD4769667	DD4769667
8	◆ Shroud, Left-Hand	1	DD7920424	DD7920424
9	☆ Plug, Oil Fill	1	DD7927006	DD7927006
15	Right-Hand Shroud Components	1	(See Figure 17)	(See Figure 17)
16	Corded Remote pendant, 20 ft [6 m]	1	CC132	CC132
23	◆ Screw, Flange Button Head M6	2	DD9398048	DD9398048
◆ Items included in Upper Shroud Kit, XC2USK.				
☆ Items included in Oil Fill Service Kit, XC2VFK.				

Figure 17: Right-Hand Shroud Components

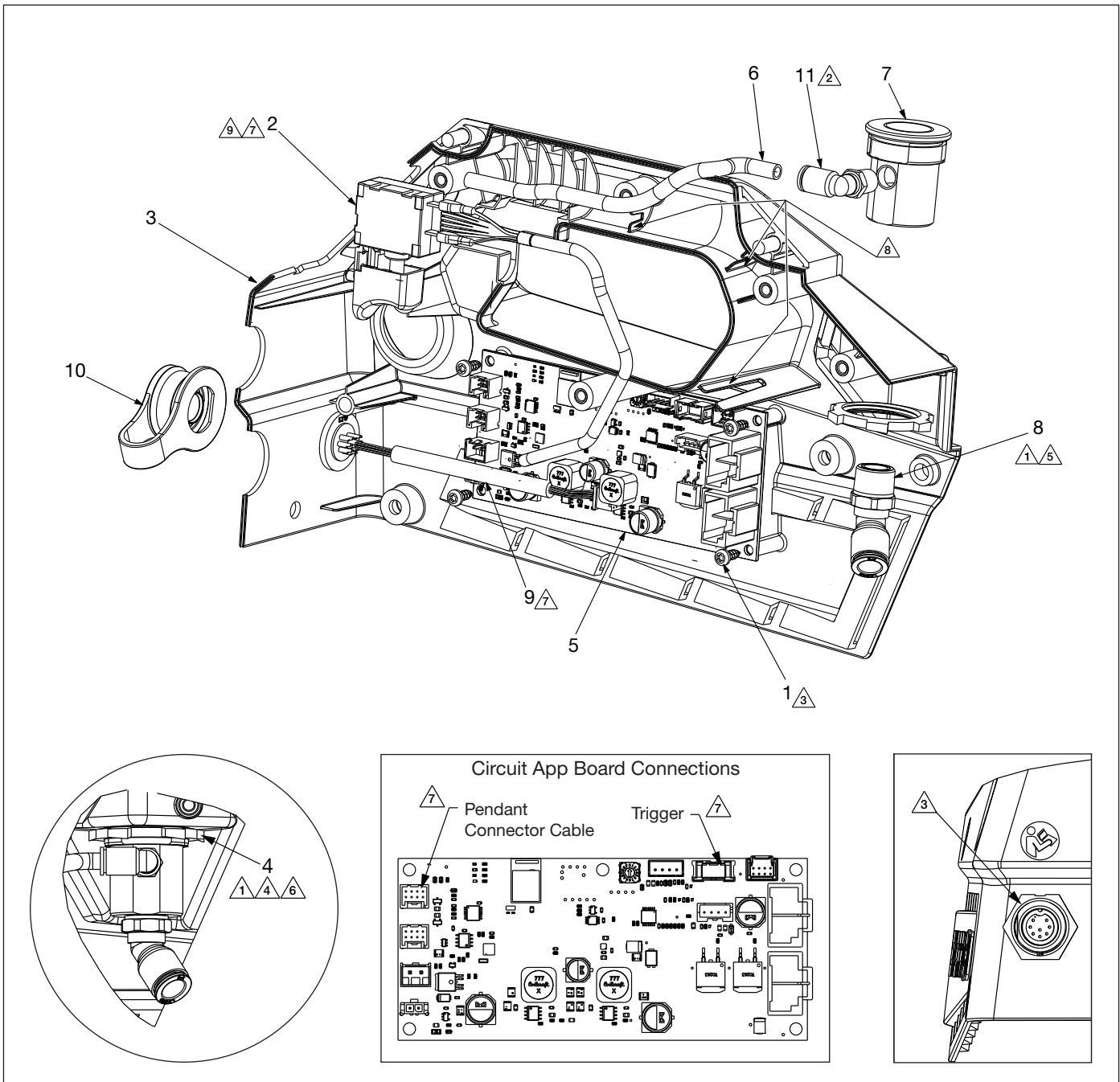

Notes:

- Ⓐ Torque to 120-144 in-lb [13.6 - 16.3 Nm].
- Ⓑ Torque to 60-80 in-lb [6.8 - 9.0 Nm].
- Ⓒ Torque to 8-10 in-lb [0.9 - 1.1 Nm].
- Ⓓ Secure with Loctite 271 thread locking compound.
Refer to manufacturer's technical data sheet for application instructions.
- Ⓔ Apply PTFE tape.
- Ⓕ Orient with tabs bent down away from shell.
- Ⓖ Connect to trigger and pendant connectors on circuit app board.
- Ⓗ Secure trigger cable into slots on the shroud.
- Ⓘ Trigger lock selector switch needs to be moved from the center locked position.

Parts List for Figure 17

Item		Description	Qty	Part Number
1	✱	Screw, M4 x 10 Thrd FRM	5	DD3883028
2	☆	Trigger, Variable Speed	1	DD7874372
3	◆	Shroud, Right-Hand	1	DD7921424
4	☆	Retainer, XC2 Oil Fill	1	DD7926160
5	✱	Circuit App Board	1	DD7929827
6	†	Tube, Oil Vent	1	DD7962268
7	☆	Threaded Insert, Oil Fill	1	DD7966225
8	† ☆	Fitting, Elbow 45, Tube	1	DD8426097
9		Cord, Pendant Connector	1	DD8667960SR
10		Dust Cap, C1 Pendant Connector	1	DD8729020SR
11	† ☆	Fitting-M 90	1	F100097-52
◆ Items included in Upper Shroud Kit, XC2USK.				
† Items included in Oil Fill Tube Kit, XC2TK.				
☆ Items included in Trigger Kit, XC2TRK.				
☆ Items included in Oil Fill Service Kit, XC2VFK.				
✱ Items included in PCB Service Kit, XC2ACK.				

Figure 18: Pump Base Assembly

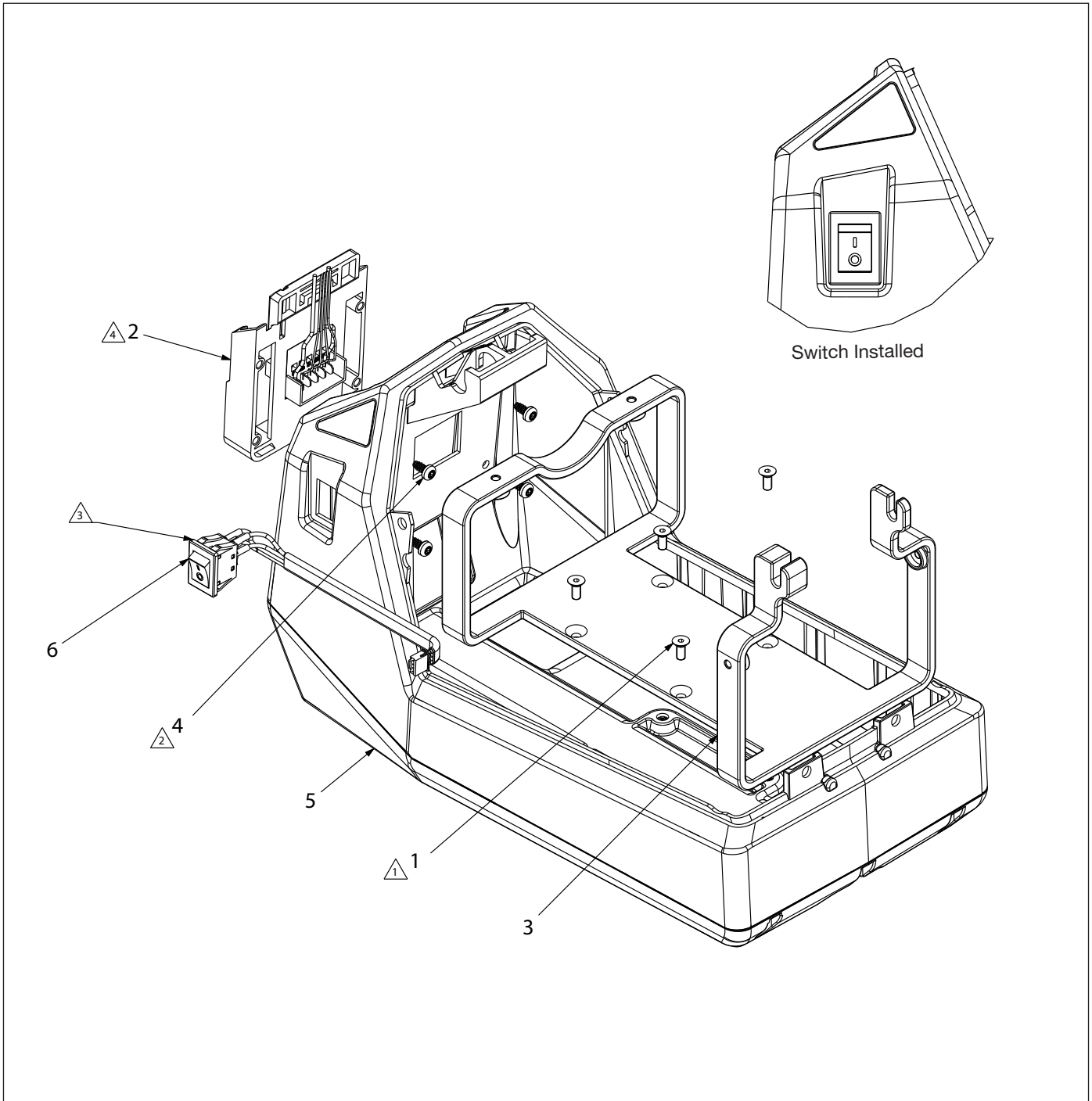

Notes:

- ⚠ 1 Torque to 18-26 in-lb [2.0 - 3.0 Nm].
- ⚠ 2 Torque to 10-12 in-lb [1.13 - 1.36 Nm].
- ⚠ 3 Pull wires for switch through hole in housing.
- ⚠ 4 Pull wires through hole in housing.

Parts List for Figure 18

Item		Description	Qty	Part Number
1	○	Screw, Flat Hd M5	4	CBA517028-1B
2	■	Plate, Battery Interface w/Cable	1	DD7953101
3		Bracket, Motor, XC2	1	DD8251111
4	■ ○	Screw, M5 x 10, Thread Forming, Torx	4	DD8781028
5	○	Base, XC2 Pump	1	DD8836005
6		Switch, Rocker DPST 30 VDC 10A	1	DD8866372SR
■ Items included in 54V Battery Guide Kit, XC2BGK.				
○ Items included in Lower Shroud Kit, XC2LSK.				

Figure 19: Power Unit & Reservoir Assembly

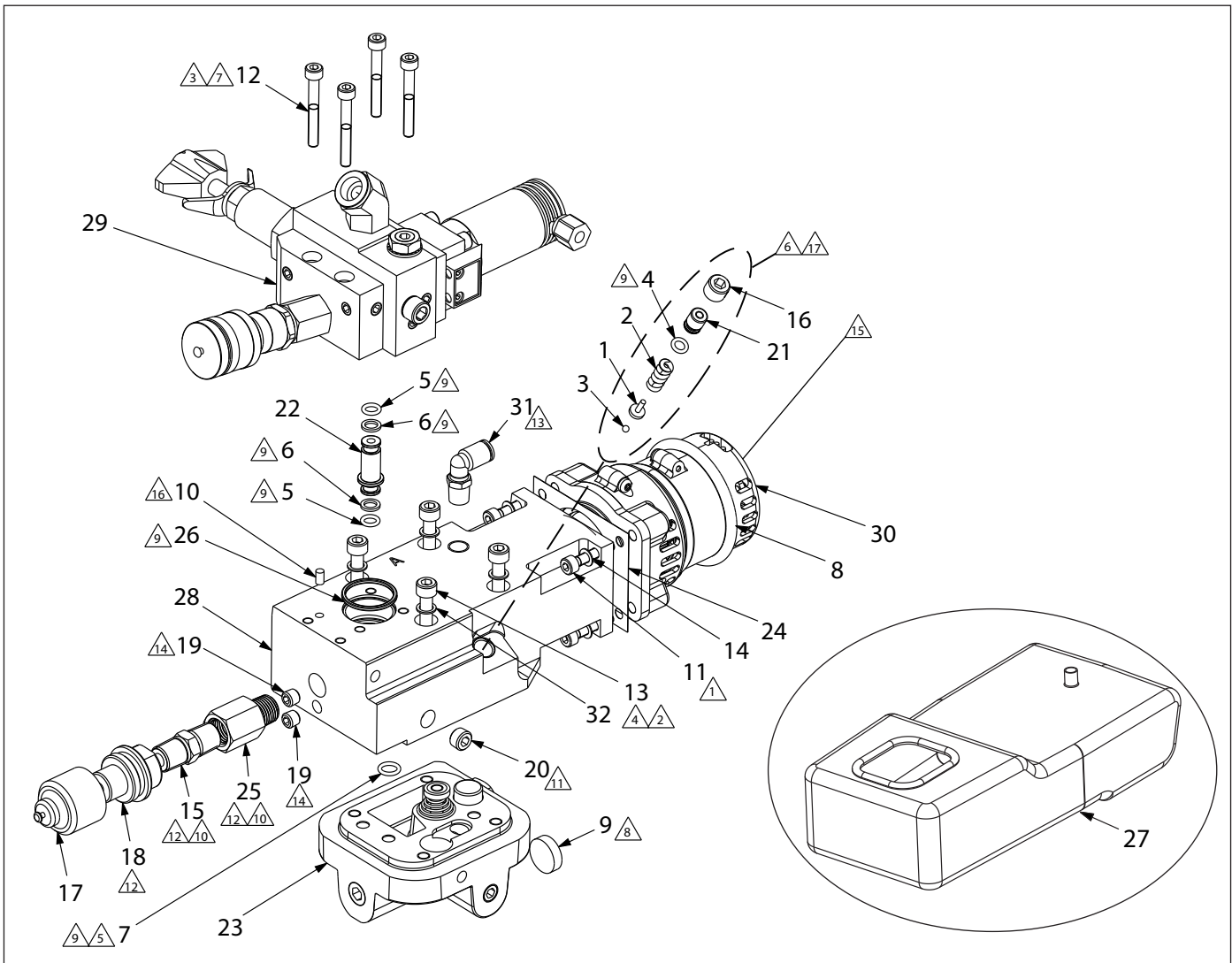

Notes:

- ① Torque to 45-60 in-lbs [5.1 - 6.8 Nm].
- ② Torque to 12-15 ft-lbs [16.3 - 20.3 Nm].
- ③ Torque to 55-65 in-lbs [6.2 - 7.3 Nm].
- ④ Secure with Loctite 2760 thread locking compound. Refer to manufacturer's technical data sheet for application instructions.
- ⑤ Install on eccentric housing (item 28).
- ⑥ Install these parts after pump element (item 23) is installed.
- ⑦ Secure with Loctite 243 thread locking compound. Refer to manufacturer's technical data sheet for application instructions.
- ⑧ Attach magnet (item 9) to pump element (item 23) prior to assembling bladder (item 27).
- ⑨ Lubricate seals before assembly.
- ⑩ Apply PTFE tape.
- ⑪ Torque to 16-19 ft-lbs [22 - 26 Nm].
- ⑫ Torque to 32-39 ft-lbs [43 - 53 Nm].
- ⑬ Torque to 60-80 in-lbs [6.8 - 9.0 Nm].
- ⑭ Torque to 120-144 in-lbs [13.6 - 16.3 Nm].
- ⑮ Orient motor so that wires exit in position shown.
- ⑯ Press fit.
- ⑰ Set relief valve to 10,150 psi [700 bar].

Parts List for Figure 19 and Figure 20

Item	Description	Qty	Part Number	
			Model XC2502B	Model XC2504B
1	□ Ball Cap	1	A8038570	A8038570
2	□ Spring, Compression	1	A8126110	A8126110
3	□ Ball, 0.125, Stl	1	B1003016	B1003016
4	★ ■ O-Ring, Round, 0.219, 0.344, 0.063	1	B1004503	B1004503
5	** O-Ring, Round, 0.250, 0.375, 0.063	2	B1005503	B1005503
6	**★ Back-up, Split, 0.250, 0.375, 0.045	2	B1010564	B1010564
7	★ ❖ ▲ ▼ O-Ring, Round, 0.313, 0.438, 0.063	1	B1011803	B1011803
8	⊗ O-Ring, Round, 2.000, 2.375, 0.188	1	B1032503	B1032503
9	Magnet	1	C187018	C187018
10	* Dowel Pin, 4 mm Dia x 8 mm Lg	1	CAA411061-2B	CAA411061-2B
11	❖ ⊗ Screw, SHCS, M5 x 25	4	CCA523028-1A	CCA523028-1A
12	** Screw, SHCS, M5 x 40	4	CCA529028-1A	CCA529028-1A
13	❖ ▲ ▼ Screw, SHCS, M6 x 55	4	CCA635028-1A	CCA635028-1A
14	❖ ⊗ Washer, Lock M5	4	CCE1050108-6A	CCE1050108-6A
15	Nipple-Pipe, 1/4 x 1/4 NPTF Stl	1	CJ647096	CJ647096
16	□ Set Screw, Cup Point Nylock	1	DC10131048	DC10131048
17	Dust Cap	1	DC6187234	DC6187234
18	Coupler	1	TH630	TH630
19	❖ PTF - SAE Flush Plug 0.062	2	DC6792245	DC6792245
20	❖ PTF - SAE Flush Plug 0.125	1	DC6793245	DC6793245
21	□ Plug	1	DC7234009	DC7234009
22	* Transfer Tube	1	DD2996268	DD2996268
23	Pump Element	1	(See Figure 25)	(See Figure 25)
24	⊗ Gasket	1	DD6917037	DD6917037
25	Adapter, 1/4 NPTF Female x Male Straight	1	DD7386038	DD7386038
26	** Quad-Ring, XCTW, Valve Body	1	DD7437203	DD7437203
27	▲ Bladder, 2L	1	DD8266025	- - -
	▼ Bladder, 4L	1	- - -	DD8184025
28	Eccentric Shaft & Housing Subassy	1	(See Figure 23)	(See Figure 23)
29	Control Valve Assembly, 4-Way, 2-Position, Solenoid Operated	1	(See Figure 21)	(See Figure 21)
30	⊗ Motor, Sub Assembly	1	DD8826900	DD8826900
31	Fitting- M 90	1	F100097-52	F100097-52
32	★ ▲ ▼ ❖ Gasket	4	S3037	S3037

Note: Refer to table on page 35 for parts kits.

Figure 20: Power Unit & Reservoir Assembly (repeated view)

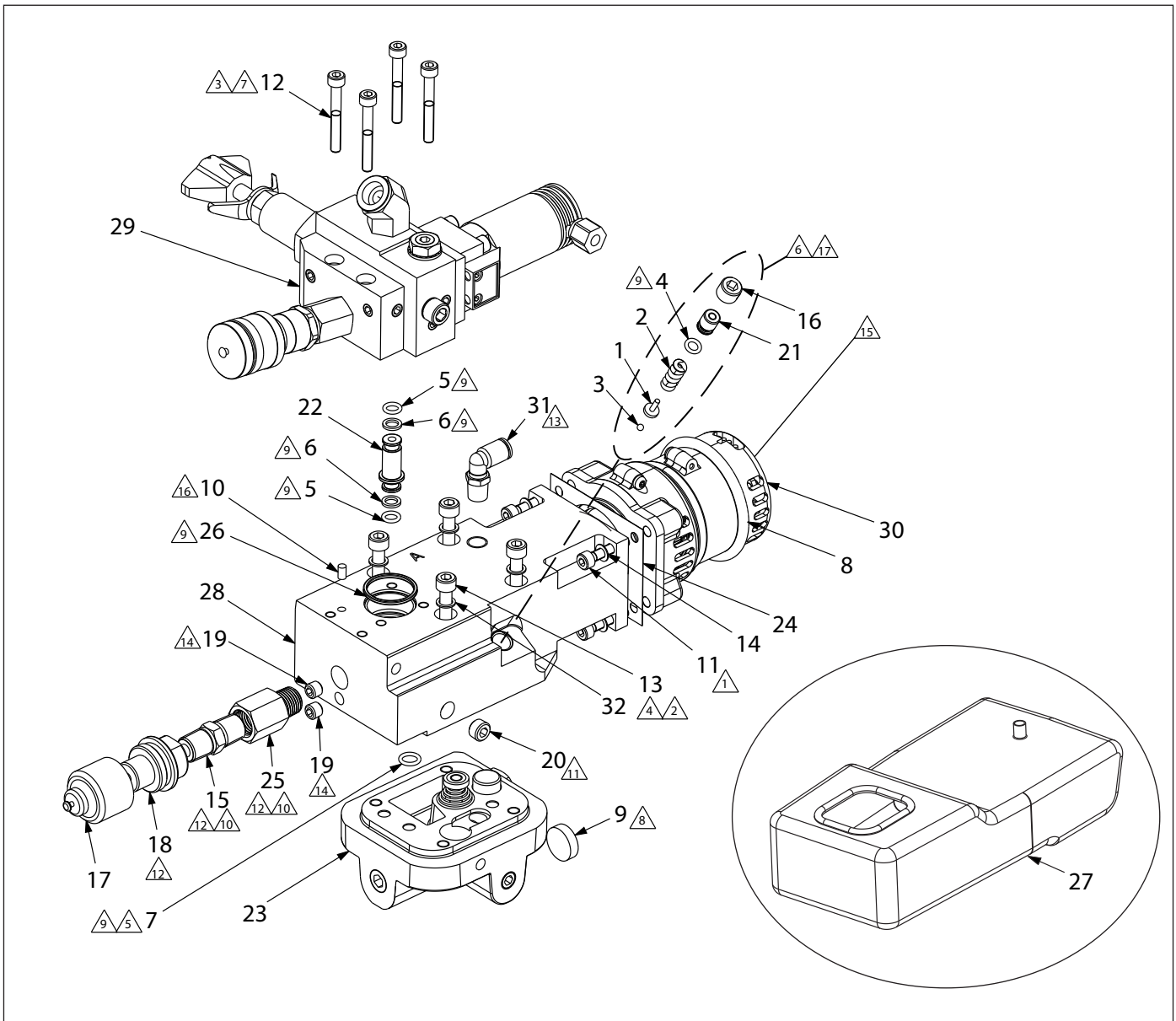

Notes:

- ⚠ Torque to 45-60 in-lbs [5.1 - 6.8 Nm].
- ⚠ Torque to 12-15 ft-lbs [16.3 - 20.3 Nm].
- ⚠ Torque to 55-65 in-lbs [6.2 - 7.3 Nm].
- ⚠ Secure with Loctite 2760 thread locking compound. Refer to manufacturer's technical data sheet for application instructions.
- ⚠ Install on eccentric housing (item 28).
- ⚠ Install these parts after pump element (item 23) is installed.
- ⚠ Secure with Loctite 243 thread locking compound. Refer to manufacturer's technical data sheet for application instructions.
- ⚠ Attach magnet (item 9) to pump element (item 23) prior to assembling bladder (item 27).
- ⚠ Lubricate seals before assembly.
- ⚠ Apply PTFE tape.
- ⚠ Torque to 16-19 ft-lbs [22 - 26 Nm].
- ⚠ Torque to 32-39 ft-lbs [43 - 53 Nm].
- ⚠ Torque to 60-80 in-lbs [6.8 - 9.0 Nm].
- ⚠ Torque to 120-144 in-lbs [13.6 - 16.3 Nm].
- ⚠ Orient motor so that wires exit in position shown.
- ⚠ Press fit.
- ⚠ Set relief valve to 10,150 psi [700 bar].

Parts Kits for Figure 19 and Figure 20

Kit Symbol	Description
▲	Items included in XC2 2L Bladder Kit, XC2B2LK.
▼	Items included in XC2 4L Bladder Kit, XC2B4LK.
★	Items included in XCTW Pump Seal Kit, XC3SK.
▣	Items included in Service Kit, XA1UARVK.
■	Items included in 54V Battery Guide Kit, XC2BGK.
❖	Items included in Eccentric Housing Service Kit, XC2ECK.
♻️	Items included in 54V Brushless Motor Service Kit, XC2EMK.
✱	Items included in XC2 TW Valve Seal Kit, XC3TVSK.
✱	Items included in TW Valve Kit, XC2TWVK.
Note: Refer to table on page 33 for parts list and descriptions of kit parts.	

Figure 21: Control Valve Assembly, View 1 of 2

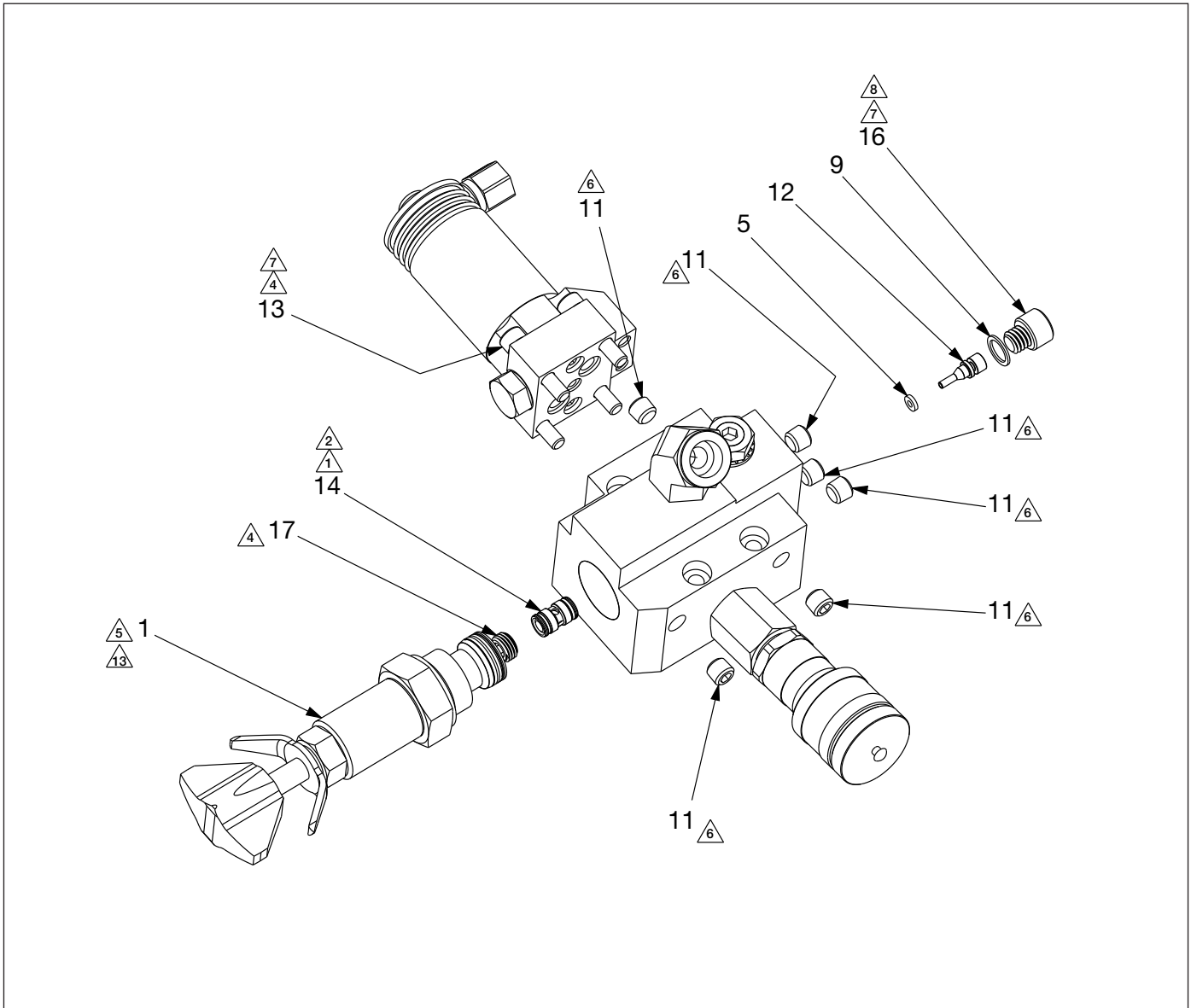

Notes:

- ① Lubricate with oil prior to assembly.
- ② Press fit, 825-875 psi [56.8 - 60.3 bar] on a 10 ton press.
- ④ Torque to 55-65 in-lbs [6.21 - 7.34 Nm].
- ⑤ Torque to 49-59 ft-lbs [66.5 - 79.9 Nm].
- ⑥ Torque to 120-144 in-lbs [13.56 - 16.27 Nm].
- ⑦ Secure with Loctite 243 thread locking compound.
- Refer to manufacturer's technical data sheet for application instructions.
- ⑧ Torque to 90-100 in-lbs [10.17 - 11.30 Nm].
- ⑬ Refer to Section 7.3 of this manual for relief valve setting instructions.

Parts List for Figure 21

Item		Description	Qty	Part Number
1		Cartridge Relief Valve	1	45423SR
5	*	Back up Ring, Split, 0.094, 0.219, 0.045	1	B1005564
9	*	Copper Gasket	1	C846037
11		PTF-SAE Flush Plug 0.062	6	DC6792245
12	*	Piston, B-Side Pilot	1	DD4790051
13		Solenoid Valve, 3-Way, 2-Position, Electric	1	DD5655660SR
14		Shuttle Valve Cartridge Assembly	1	DD6005900
16	*	5/16-18 x 1/4 SHCS	1	DD6576028
17		Hollow Set Screw, 1/8"-24 UNF x 0.1875	1	DD6957027
* Items included in XC2 TW Valve Seal Kit, XC3TVSK.				

Figure 22: Control Valve Assembly, View 2 of 2

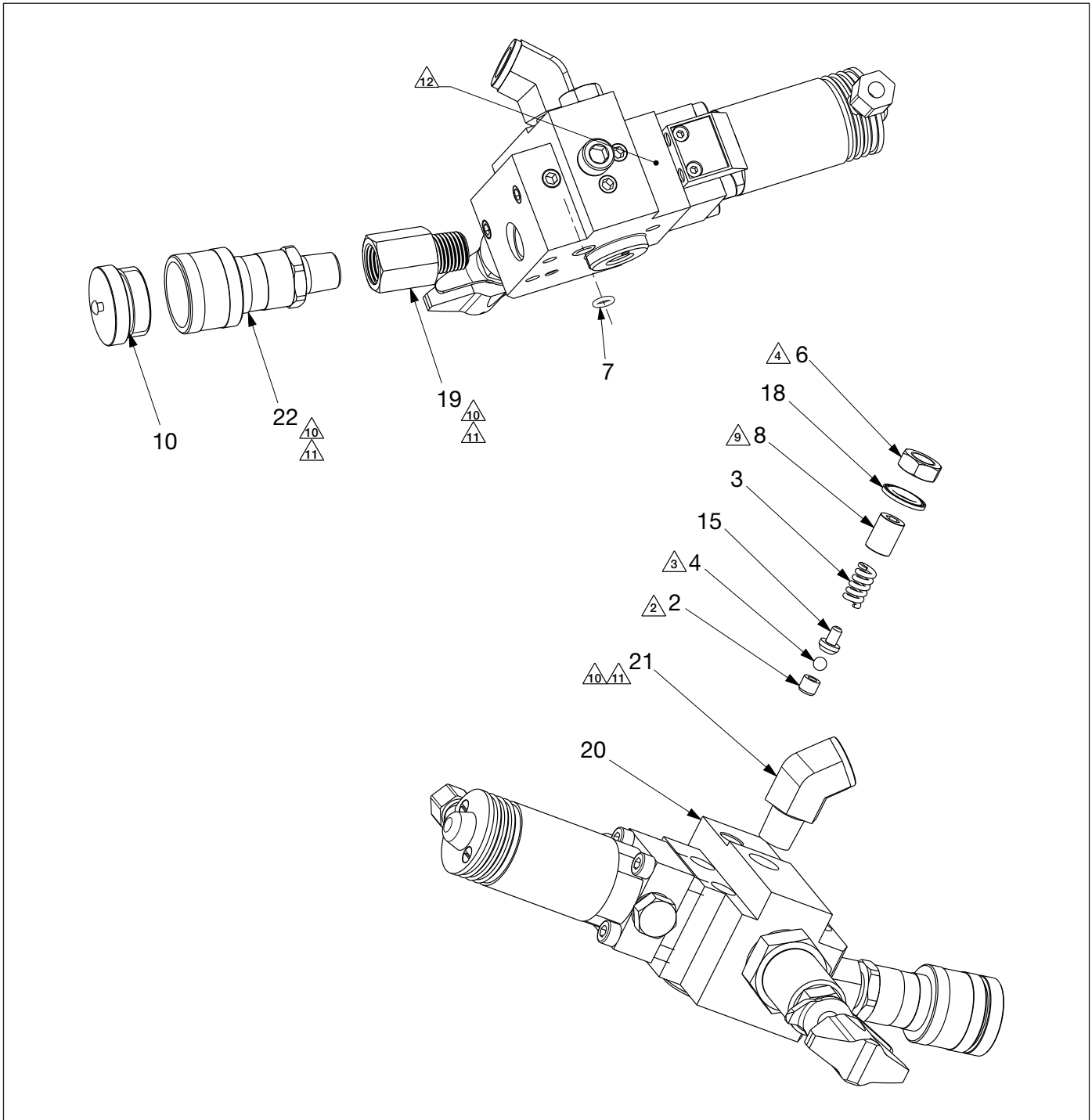

Notes:

- ② Press fit, 825-875 psi [56.8 - 60.3 bar] on a 10 ton press.
- ③ Coin, 275-325 psi [6.2 - 7.3 bar] on a 10 ton press.
- ④ Torque to 55-65 in-lbs [6.21 - 7.34 Nm].
- ⑨ B-Side relief valve set to 2,600 +/- 100 psi [180 +/- 7 bar].
- ⑩ Torque to 32-39 ft-lbs [43.4 - 52.8 Nm].
- ⑪ Apply PTFE tape.
- ⑫ Product information located here.

Parts List for Figure 22

Item		Description	Qty	Part Number
2		Seat	1	A8015290
3	*●	Spring	1	A8038110
4	*●	Ball, 0.188 Stl	1	B1005016
6	*●	Hex Jam Nut	1	B1006124
7	**	O-Ring, Round, 0.219, 0.344, 0.063	1	B1009803
8	*●	Set Screw, Flat Point	1	BF3808027F
10		Dust Cap, Metal, Female	1	DC6629020
15	*●	Ball Guide	1	DD6573013
18	*●	Sealing Washer	1	DD7232314
19		Adaptor, Straight 1/4 NPTF x Fem x Male	1	DD7386038
20		Manifold, XC2 TW 4W 2P Valve	1	DD9061840
21		45° Fitting Elbow, Male-Female, 1/4 NPTF	1	F100095
22		Coupler, Female	1	TR630
* Items included in XC2 TW Valve Seal Kit, XC3TVSK.				
● Items included in B-Side Relief Kit, XC3BRK.				
* Item included in TW Valve Kit, XC2TWVK.				

Figure 23: Eccentric Shaft & Housing Subassembly

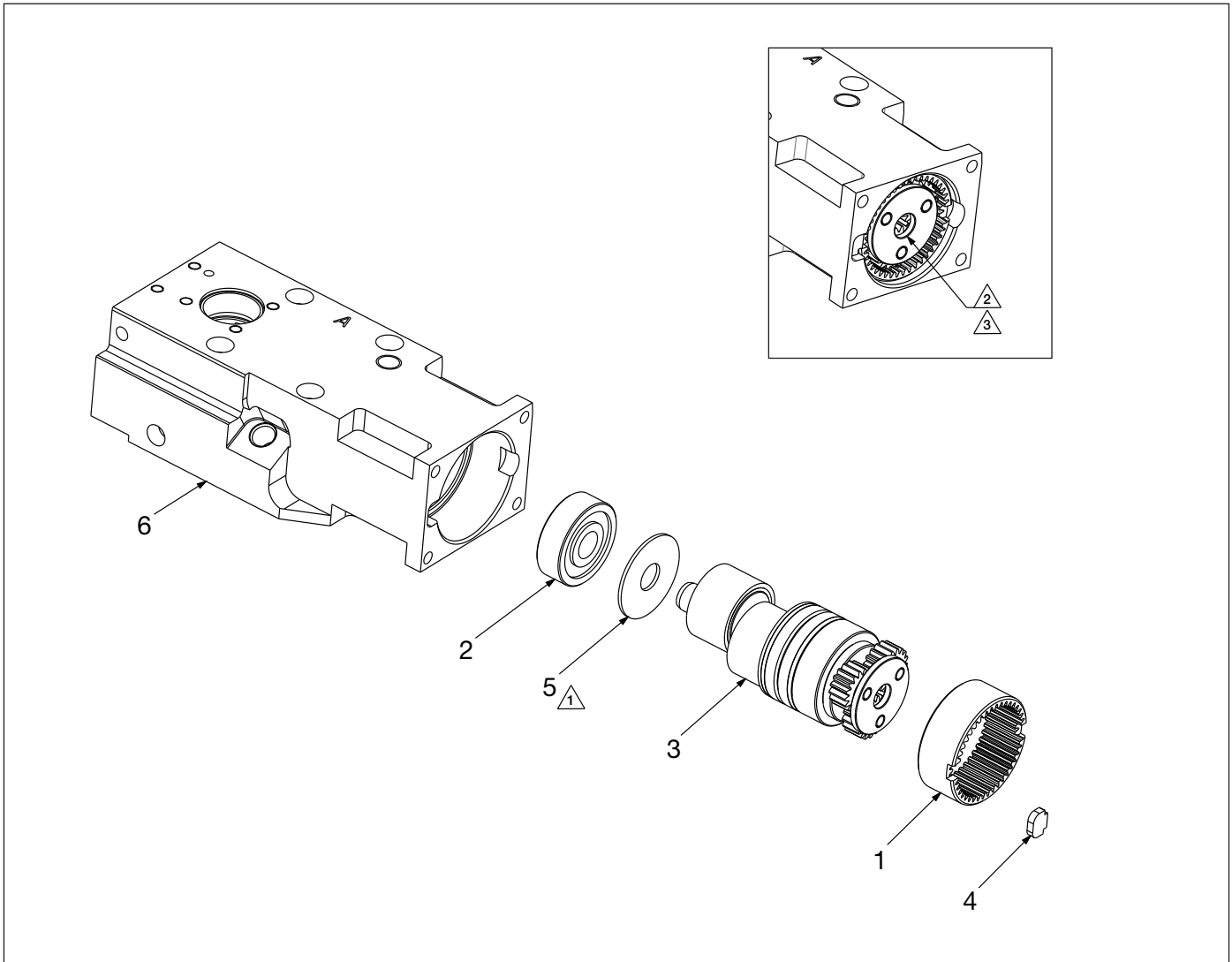

Notes:

- ⚠ Position grey coated side of bushing (item 5) toward eccentric (item 3).
- ⚠ Spin test after assembly (1 full eccentric rotation).
- ⚠ Use a pick to align the gears with the ring gear.

Parts List for Figure 23

Item		Description	Qty	Part Number
1	❖	Ring Gear	1	DC7089228
2	❖	Bearing	1	DC7096155
3	❖	Assembly, Eccentric Shaft	1	(See Figure 24)
4	❖ ⚙	Key, Ring Gear	1	DC7452251
5	❖	Bushing	1	DC7464108
6	❖	Eccentric Housing	1	DD8425001
❖ Items included in Eccentric Housing Service Kit, XC2ECK.				
⚙ Items included in 54V Brushless Motor Service Kit, XC2EMK.				

Figure 24: Eccentric Shaft Assembly

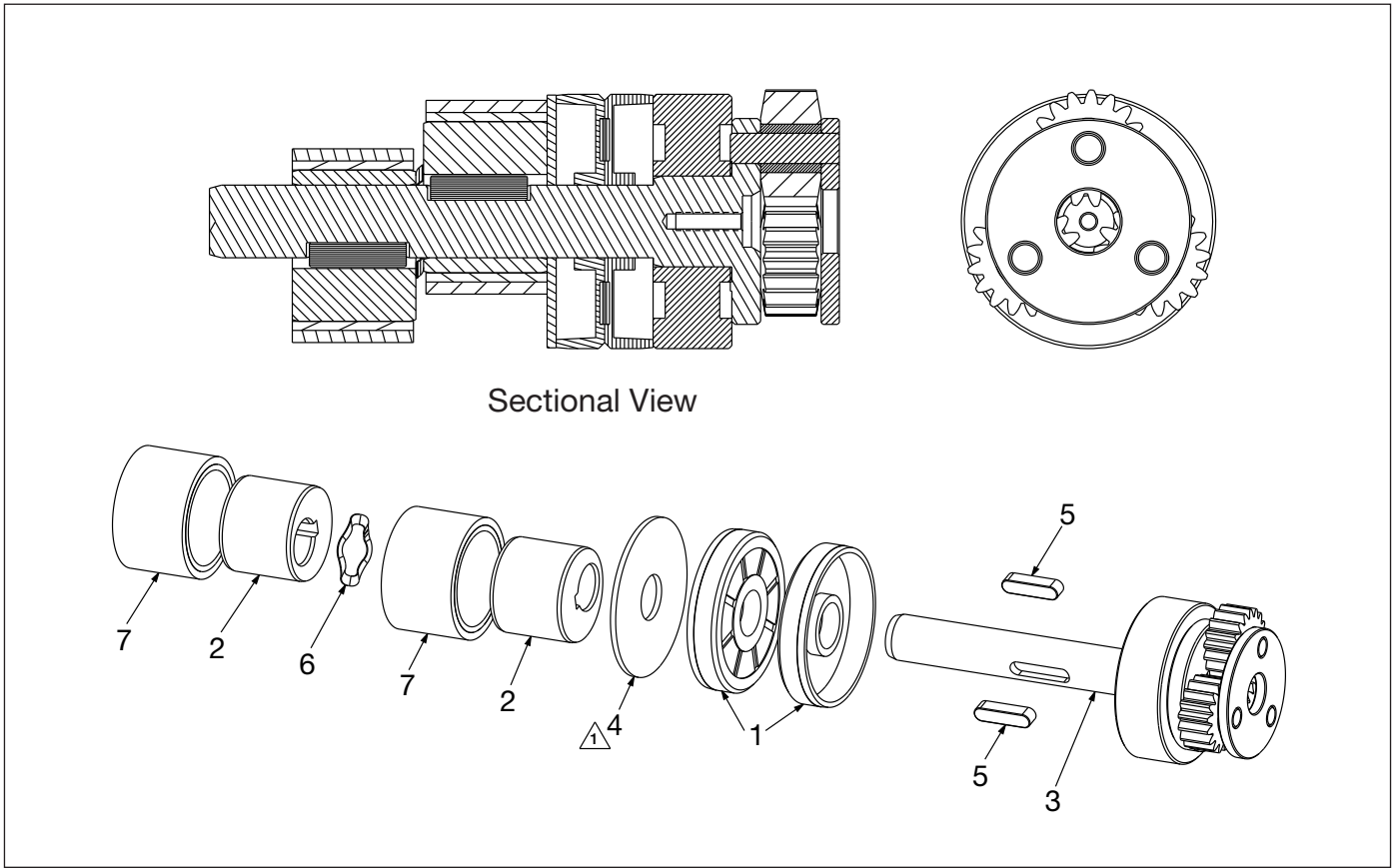

Note:

△ Position grey coated side of thrust washer (item 4) toward lip seal (item 1).

Figure 25: Pump Element

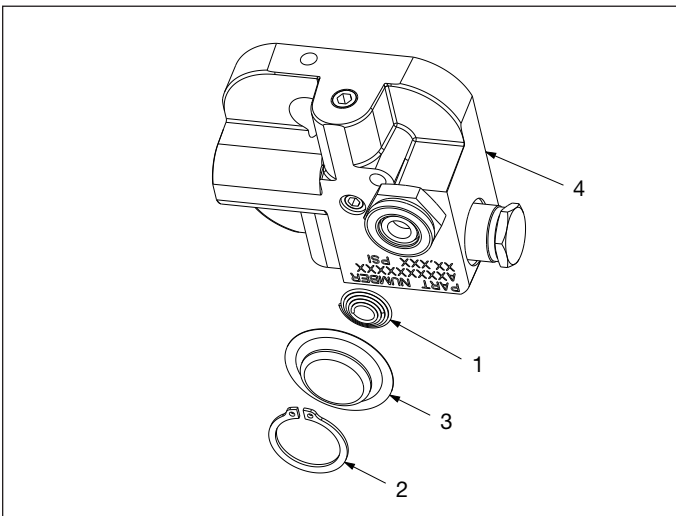

Parts List for Figure 24

Item		Description	Qty	Part Number
1	❖	Lip Seal	2	DC7090476
2	❖	Eccentric, 4mm	2	DC7117537
3	❖	Subassembly, Eccentric Shaft	1	DC7870950
4	❖	Washer, Thrust	1	DC7186108
5	❖	Key	2	DC7191251
6	❖	Spring, Wave	1	DC7750410
7	❖	Subassembly, Cam	2	DC7755950
❖ Items included in Eccentric Housing Service Kit, XC2ECK.				

Parts List for Figure 25

Item		Description	Qty	Part Number
1	◆	Spring, Conical	1	BSS5509D
2	◆	Retaining Ring, External, 25 mm Stl	1	CCA1025044-1A
3	◆	Screen	1	DC7152018
4	◆	Pump Element Components	1	(See Figure 26)
◆ Items included in XVARI Pump Element Kit, XA1PEK.				

Figure 26: Pump Element Components

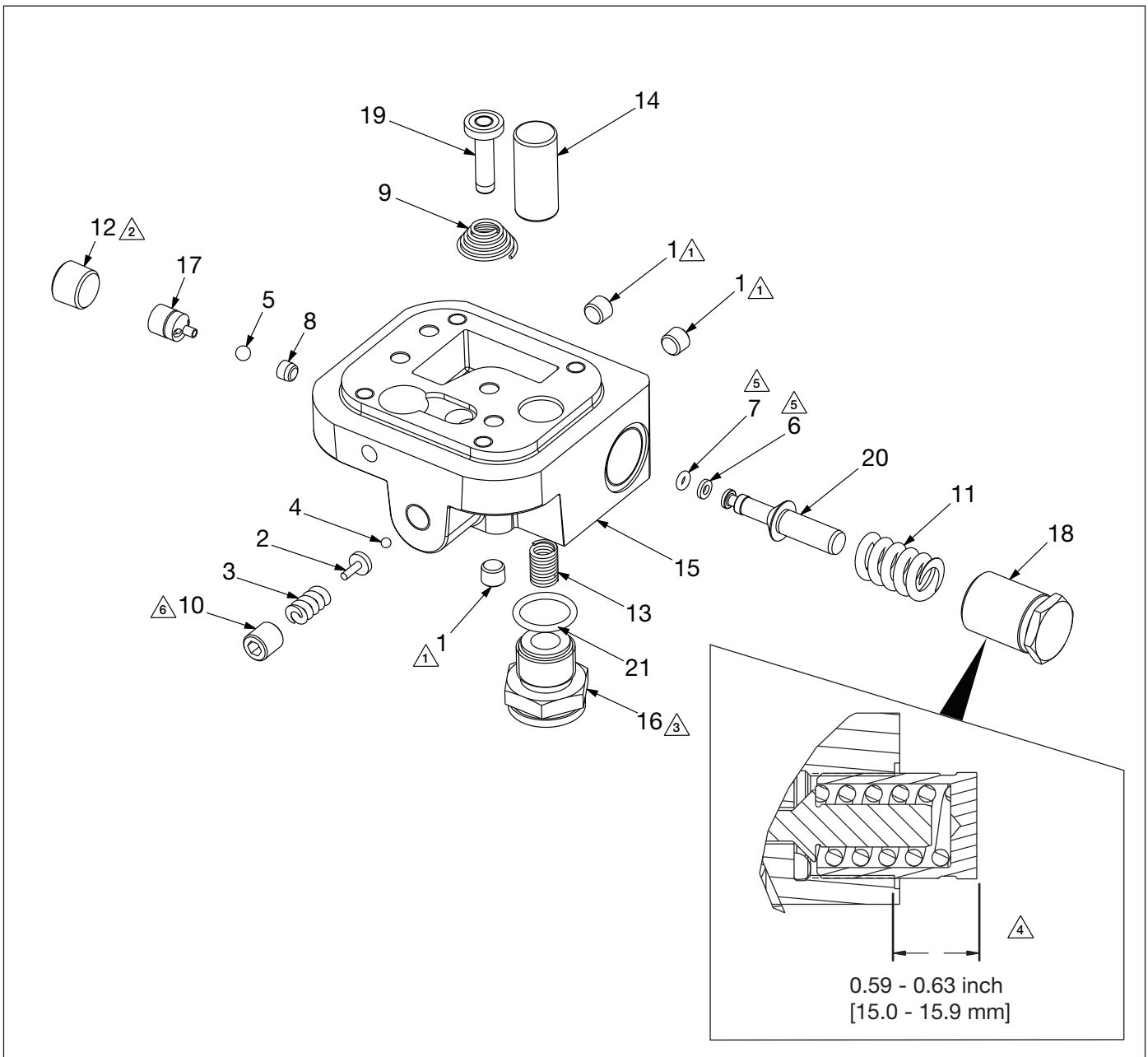

Notes:

- △1 Torque to 9.6-11.8 ft-lb [13 - 16 Nm].
- △2 Torque to 44.3-52.3 ft-lb [60 - 71 Nm].
- △3 Torque to 18.5-22.1 ft-lb [25 - 30 Nm].
- △4 Adjust length of bypass end cap (item 18) to between 0.59-0.63 inch [15.0 - 15.9 mm] from spot face.
- △5 Lubricate seals before assembly.
- △6 Relief valve to be set at 10,400-10,800 psi [717 - 714 bar].

Parts List for Figure 26

Item		Description	Qty	Part Number
1	◆	Plug, Flush, Hex 27.0 Stl Teflon	3	A1006245
2	◆	Ball Cap	1	A8038570
3	◆	Spring, Compression	1	A8126110
4	◆	Ball, 0.125 Stl	1	B1003016
5	◆	Ball 0.188 Stl	1	B1005016
6	★★◆	Back Up Ring, Split	1	B1006564
7	★★◆	O-Ring, Round, 0.125, 0.250, 0.063	1	B1006803
8	◆	Seat, Piston, Lower	1	BSS5358D
9	◆	Spring, Conical	1	BSS5509D
10	◆	Set Screw, Hollow Socket	1	DC1185048
11	◆	Spring, Bypass	1	DC394110
12	◆	PTF - SAE Flush Plug, 0.250	1	DC6794245
13	◆	Spring, Large Piston SAP	1	DC7026110
14	◆	Piston, 14 mm Dia, Lg	1	DC7027051
15	◆	Pump Body	1	DC7201190
16	◆	Plug Assembly, Inlet Check Valve	1	DC7453950
17	◆	Subassembly, Outlet Check Valve	1	DC7904900
18	◆	End Cap, Bypass	1	DC9208020
19	◆	Piston Assembly, MPE	1	DC9244920
20	◆	Piston, Bypass	1	DC9292051
21	★★◆	O-Ring (included with item 16)	1	B1908503
◆ Items included in XVARI Pump Element Kit, XA1PEK.				
★ Items included in Pump Seal Kit, XC3SK.				

Figure 27: Battery and Battery Charger

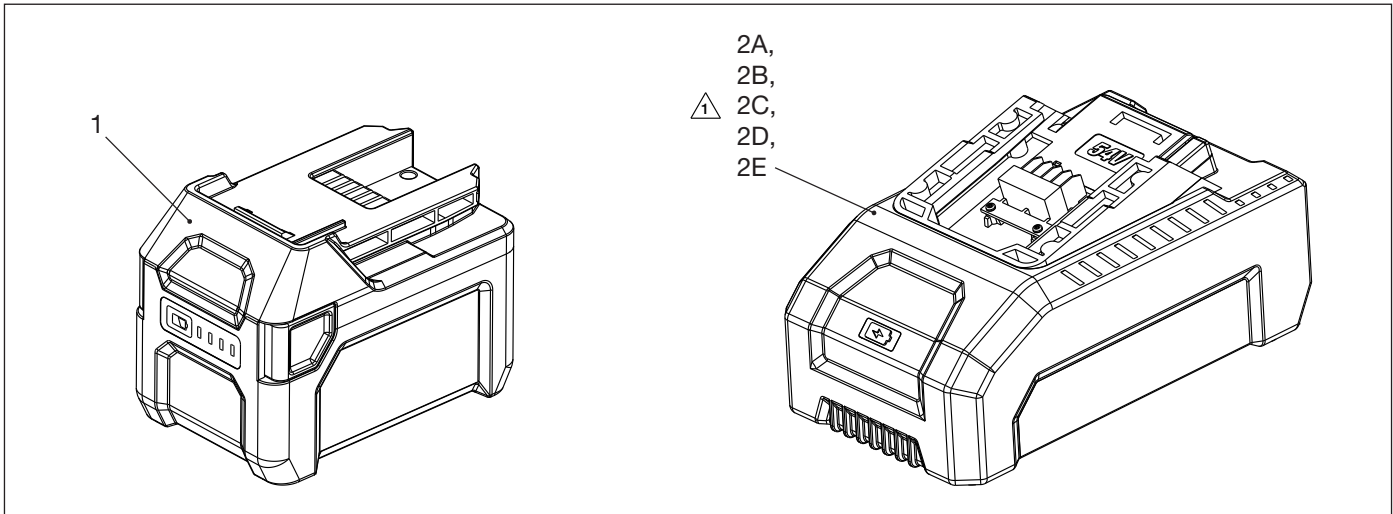

Notes: ⚠

- Charger must be purchased separately if not included in the shipment with the battery or tool. Unit is auto-voltage sensing, 100-240 VAC, 50/60 Hz.
- North America, Europe and Australia: Charger and power cord includes one Energpac EC1F54 battery charger and the AC power cord for use in the selected region. Charger not sold without power cord.
- Japan and United Kingdom: Order charger and power cord EC1F542A, EC1F541B or EC1F542E plus the power cord applicable for your region/country. Replace the power cord included with the charger with the power cord that was ordered separately (ECC541N or ECC542U).

Figure 28: Selected Accessories

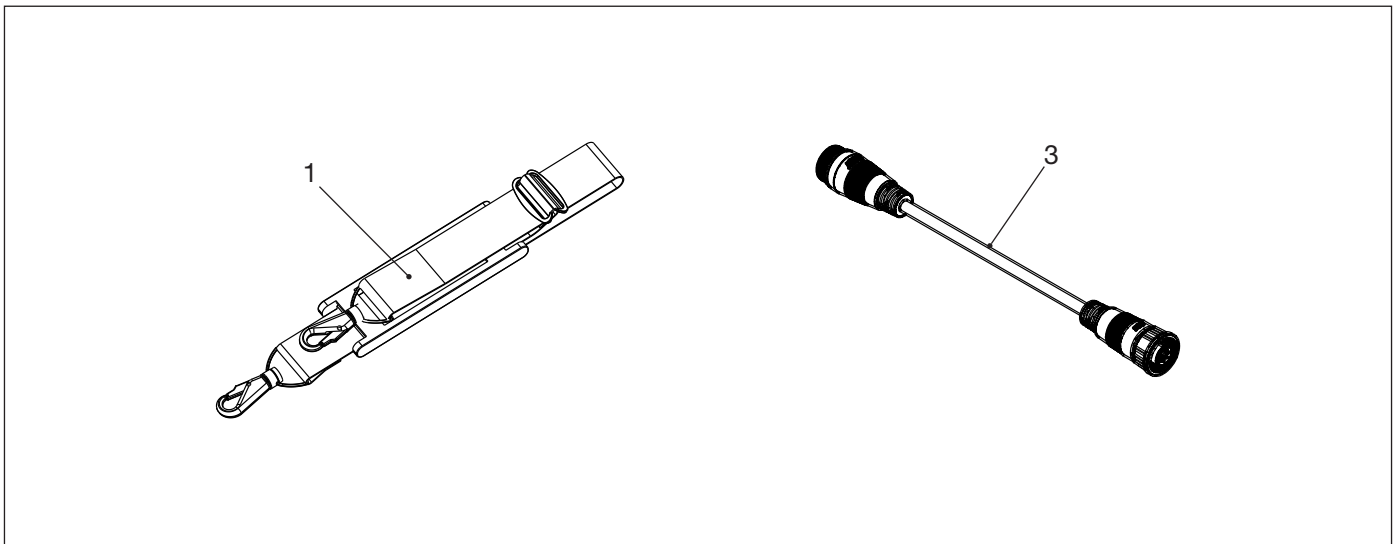

Parts List for Figure 27

Item	Description	Qty	Part Number
1	Battery, 54V, Lithium-Ion, 4.0 Ah, 216 Wh	1	EBH544
2A	Battery Charger & Power Cord, Australia - 230V	1	EC1F542A
2B	Battery Charger & Power Cord, North America - 115V	1	EC1F541B
2C	Battery Charger & Power Cord, European Union - 230V	1	EC1F542E
2D	Power Cord, Japan - 100V	1	ECC541N
2E	Power Cord, United Kingdom - 240V	1	ECC542U

Parts List for Figure 28

Item	Description	Qty	Part Number
1	Shoulder Strap, XC2 Series Pumps	1	SSTRP55
2	Pendant Extension Cord, 10 ft [3 m]	1	CC010

Figure 29: Hydraulic Schematic

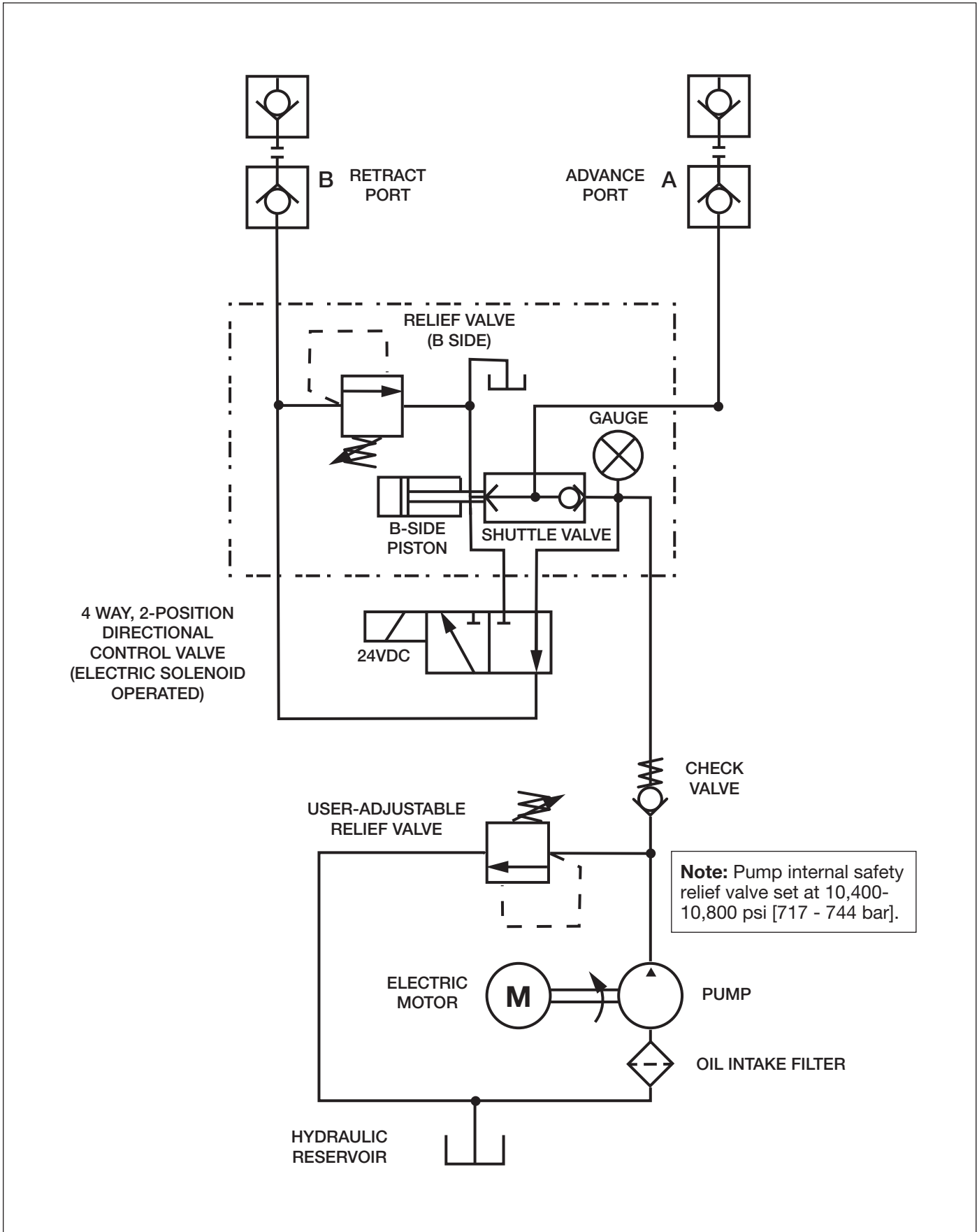
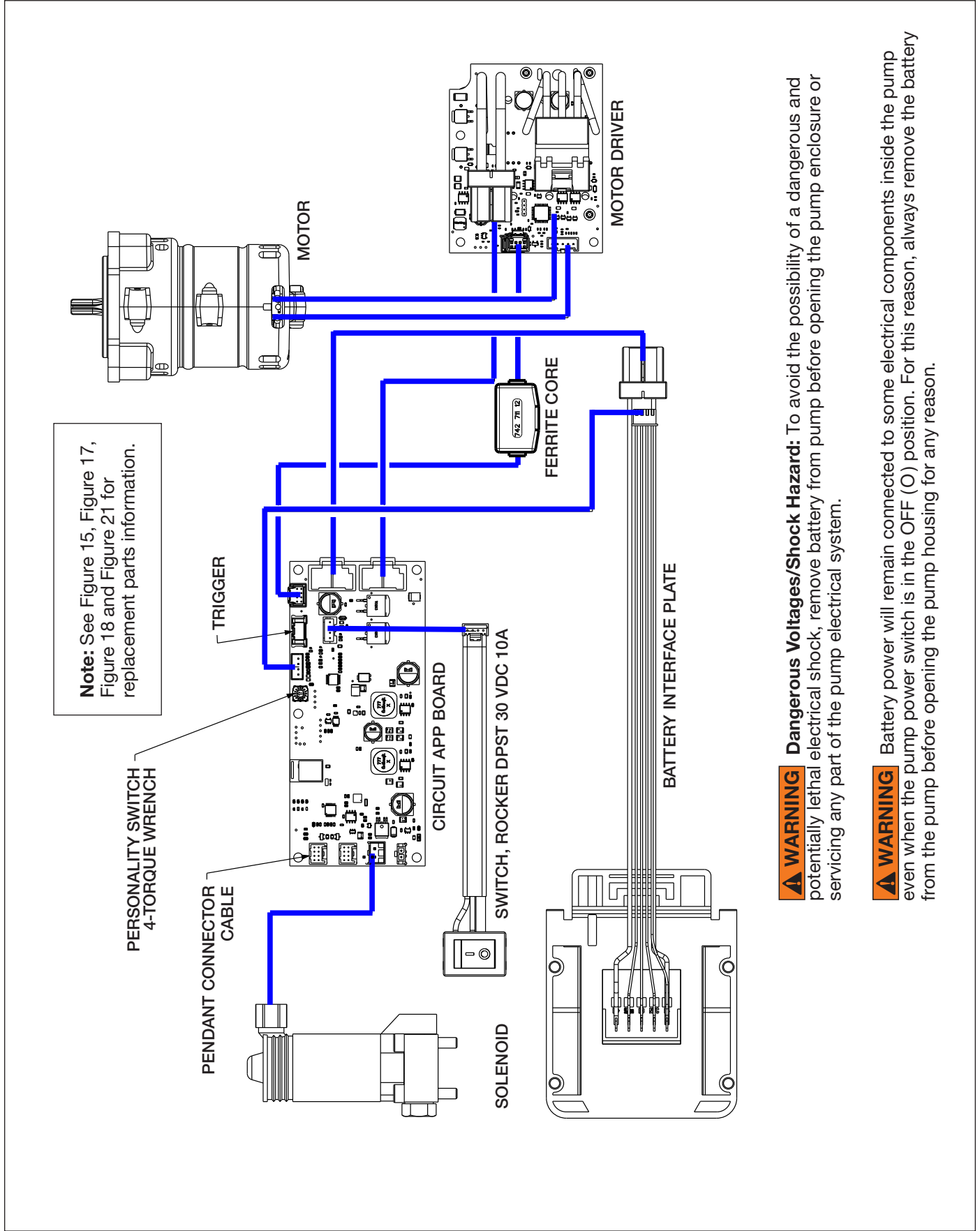

Figure 30: Electrical Schematic





ENERPAC TOOL GROUP CORP
N86 W12500 Westbrook Crossing
Menomonee Falls, WI 53051, USA