

### Z-Class Electric Pumps LCD Control Panel Operation - Firmware 7.x

L2940 Rev. A 07/09

#### 1.0 SAFETY ISSUES



Read all instructions, warnings and cautions carefully. Follow all safety precautions to avoid personal injury or property damage during system operation. Enerpac cannot be responsible for damage or injury resulting from unsafe product use, lack of maintenance or incorrect product and/or system operation. Contact Enerpac when in doubt as to the safety precautions and operations. If you have never been trained on high-pressure hydraulic safety, consult your distribution or service center for a free Enerpac Hydraulic safety course.

Failure to comply with the following cautions and warnings could cause equipment damage and personal injury.

A **CAUTION** is used to indicate correct operating or maintenance procedures and practices to prevent damage to, or destruction of equipment or other property.

A **WARNING** indicates a potential danger that requires correct procedures or practices to avoid personal injury.

A **DANGER** is only used when your action or lack of action may cause serious injury or even death.



**WARNING:** Wear proper personal protective gear when operating hydraulic equipment.



**WARNING: Stay clear of loads supported by hydraulics.** A cylinder, when used as a load lifting device, should never be used as a load holding device. After the load has been raised or lowered, it must always be blocked mechanically.



**WARNING: USE ONLY RIGID PIECES TO HOLD LOADS.** Carefully select steel or wood blocks that are capable of supporting the load. Never use a hydraulic cylinder as a shim or spacer in any lifting or pressing application.



**DANGER:** To avoid personal injury keep hands and feet away from cylinder and workpiece during operation.



**WARNING:** The system operating pressure must not exceed the pressure rating of the lowest rated component in the system. Install pressure gauges in the system to monitor operating pressure. It is your window to what is happening in the system.



**CAUTION:** Avoid damaging hydraulic hose. Avoid sharp bends and kinks when routing hydraulic hoses. Using a bent or kinked hose will cause severe back-pressure. Sharp bends and kinks will internally damage the hose leading to premature hose failure.



**Do not drop heavy objects on hose.** A sharp impact may cause internal damage to hose wire strands. Applying pressure to a damaged hose may cause it to rupture.



**IMPORTANT:** Do not lift hydraulic equipment by the hoses or swivel couplers. Use the carrying handle or other means of safe transport.

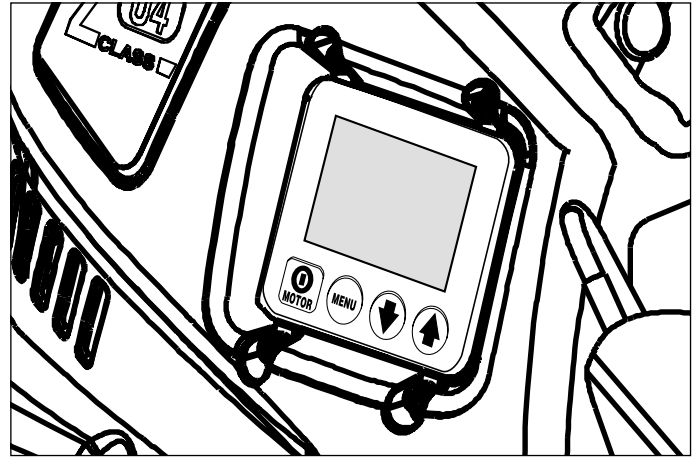

**CAUTION: Keep hydraulic equipment away from flames and heat.** Excessive heat will soften packings and seals, resulting in fluid leaks. Heat also weakens hose materials and packings. For optimum performance do not expose equipment to temperatures of 65°C [150°F] or higher. Protect hoses and cylinders from weld spatter.



**DANGER: Do not handle pressurized hoses.** Escaping oil under pressure can penetrate the skin, causing serious injury. If oil is injected under the skin, see a doctor immediately.



**WARNING:** Only use hydraulic cylinders in a coupled system. Never use a cylinder with unconnected couplers. If the cylinder becomes extremely overloaded, components can fail catastrophically causing severe personal injury.



**WARNING: BE SURE SETUP IS STABLE BEFORE LIFTING LOAD.** Cylinders should be placed on a flat surface that can support the load. Where applicable, use a cylinder base for added stability. Do not weld or otherwise modify the cylinder to attach a base or other support.



**Avoid situations where loads are not directly centered on the cylinder plunger.** Off-center loads produce considerable strain on cylinders and plungers. In addition, the load may slip or fall, causing potentially dangerous results.



**IMPORTANT:** Hydraulic equipment must only be serviced by a qualified hydraulic technician. For repair service, contact the Authorized ENERPAC Service Center in your area. To protect your warranty, use only ENERPAC oil.



**WARNING:** Immediately replace worn or damaged parts with genuine ENERPAC parts. Standard grade parts will break causing personal injury and property damage. ENERPAC parts are designed to fit properly and withstand high loads.



**WARNING:** Do not use electric pumps in an explosive atmosphere. Adhere to all local and national electrical codes. A qualified electrician must do installation and modification.



**WARNING:** Keep hands clear of moving parts and pressurized hoses.



**WARNING:** These pumps have internal factory adjusted relief valves, which must not be repaired or adjusted except by an Authorized Enerpac Service Center.



**WARNING:** To prevent damage to pump electric motor, check specifications. Use of incorrect power source will damage the motor.

## 2.0 STARTUP

### IMPORTANT:

- Pumps with optional pressure transducer: Review Automode information in sections 4.0 and 5.0 before starting pump.
- Pumps with optional pressure switch: Review section 6.7.G before starting pump.

1. Check the oil level of pump and add oil if necessary. Refer to pump instruction sheet.
2. Make sure the shipping plug has been removed and the breather cap is installed. Refer to pump instruction sheet.
3. Place manual control valve (all models NOT equipped with electric valve) in the Neutral position.
4. Connect unit to power. Wait about 2 seconds - until "READY" is displayed - before pressing any button on shroud or pendant. Refer to section 6.2 for additional boot sequence information

**Note:** During the boot sequence, the microprocessor will identify operation of any button as a potential malfunction and will prevent the motor from starting. Reset by disconnecting power for 10 seconds.

5. Adjust relief valve as described in section 5.0.
6. For Motor On/Off and valve operation: refer to sections 3.1 through 3.4 for instructions applicable to your specific valve and pendant configuration. For models equipped with a foot switch, refer to section 3.5.

## 3.0 VALVE, PENDANT AND FOOT SWITCH OPERATION

### 3.1 Manual Valve Operation

**VM32** (See Fig. 1)

1. Advance
2. Retract

Shroud On/Off=  
Toggle Motor On or Off

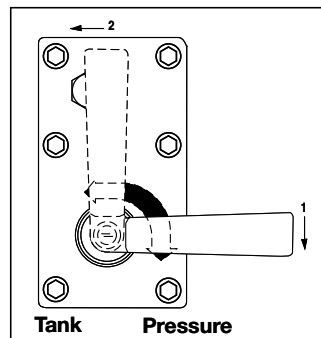

**Figure 1**

### 3.2 VM33, VM33L, VM43, and VM43L

(See Fig. 2)

1. Advance
2. Retract
3. Neutral

Shroud On/Off =  
Toggle Motor On or Off

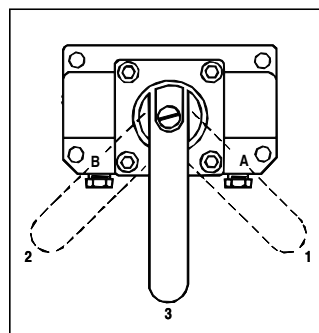

**Figure 2**

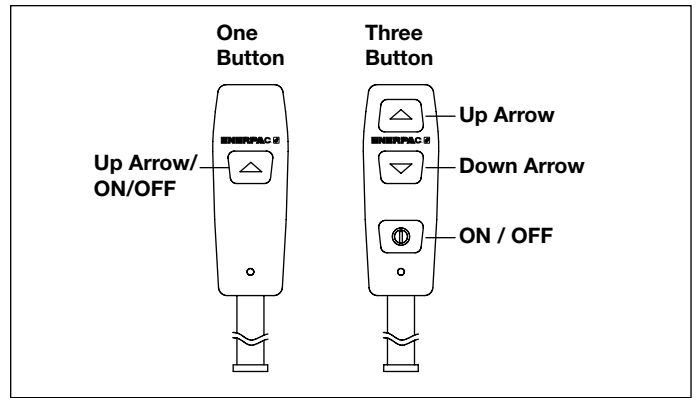

**Figure 3, Pendant Button Variations**

### 3.3 VE33, VE43 and VEW43P Electric Valves with 3-Button Pendant Operation

Also known as a Remote Pump - oil flow and motor are both controlled by the pendant (see Fig. 3).

1. Up Arrow = Momentary Advance
2. Down Arrow = Momentary Retract
3. On/Off = Toggle Motor On or Off

Shroud On/Off = Toggle motor On or Off

### 3.4 VE32D Electric Valve with 1-Button Pendant Operation

Also known as a Dump Pump - Oil flow and motor are both controlled by the pendant. The pump will run and the cylinder will advance when the pendant button is pressed. Releasing the button will stop the pump and the cylinder will retract automatically (see Fig. 3).

1. Up Arrow = Momentary Advance  
Shroud On/Off = Toggle Motor Off Only

### 3.5 Valves with foot switch (See Fig. 4)

#### A. All valves except VE32D

1. Momentary advance or motor on
2. Momentary retract (if applicable)

Shroud On/Off = Toggle Motor On or Off

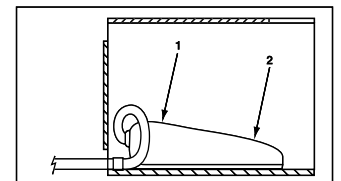

**Figure 4**

#### B. VE32D valves

1. Not used
2. Momentary advance

Shroud On/Off = Toggle Motor Off

**4.0 AUTOMATIC PUMP OPERATION  
(Pumps equipped with pressure transducer option)**

Pumps equipped with the pressure transducer option have the ability to react automatically at a user-defined upper and lower pressure value. This feature is called “Automode”.

Automode can be turned on or off as desired, at the LCD control panel.

Automode controlled operation of the motor and electric valve (if equipped) will vary, depending on pump type . The pump type appears briefly on the LCD when power is connected to the pump.

Refer to Table 1 for a list of the pump types covered in this manual. Refer to Table 4, *Pump Model Matrix*, (located near the end of this document) for a description of the specific operational characteristics for each pump type.

**Table 1 - Pump Types**

Number	Pump/Valve Description
1 . . . . .	Manual w/LCD (manual valve)
2 . . . . .	Advance/Hold /Retract (electric valve)
3 . . . . .	Dump (electric valve)
6 . . . . .	Remote 3 or 4-Way (electric valve)
8 . . . . .	Jog (manual valve)
10 . . . . .	.3 or 4-Way Manual Momentary Local Mode Default (electric valve)

**4.1 Overview of Automode Operation**

Refer to paragraphs A through D of this section for an overview of Automode operation and features.

**4.1 A. If Automode is ON, and LO PRESS setting is greater than zero (Pump types 1, 2, 6, 8 and 10)**

**I. Before the HI PRESS value is reached:**

- The pendant buttons and shroud On/Off button will function as described in sections 3.1 – 3.4.
- The text “AUTO” will be shown on the LCD, reminding the operator that Automode is active, and that the pump will take control when system pressure rises to the HI PRESS value.

**II. After the HI PRESS value is reached:**

- **Pump types 1 and 8:** The pump motor will stop.
- **Pump type 2:** The pump motor will stop and the electric valve will shift.
- **Pump types 6 and 10:** The pump motor will keep running and the electric valve will shift.
- The LCD text will change from “AUTO” to “AUTO ON” and the LCD backlight will begin flashing on and off. This indicates that Automode is now controlling pump operation automatically as required to maintain the set pressure range.



**WARNING:** All personnel must be aware that motor can start and/or valve can shift at any time when backlight is flashing and “AUTO ON” is displayed on the LCD.



**WARNING:** Always set Automode to OFF and disconnect electrical power to pump before disconnecting hoses or performing any adjustments, maintenance or repairs.

**III. When system pressure drops to the LO PRESS value:**

- **Pump types 1 and 8:** The pump motor will restart.
- **Pump types 6 and 10:** The electric valve will shift.
- **Pump type 2:** The pump motor will restart and the electric valve will shift.

**4.1 B. If Automode is ON, and LO PRESS setting is set to zero (0) or OFF (Pump types 1, 2, 3, 6, 8 and 10)**

**Note:** On pump type 3 only, the LO PRESS function is not used, and is automatically set to zero (0) by the microcontroller.

**I. Before the HI PRESS value is reached:**

- The pendant buttons and shroud On/Off button will function as described in sections 3.1 – 3.4.
- The text “AUTO” will be shown on the LCD, reminding the operator that Automode is active, and that the pump will take control when system pressure rises to the HI PRESS value.

**II. After the HI PRESS value is reached:**

- **Pump types 1, 2, 3 and 8:** The pump motor will stop and the electric valve will shift.
- **Pump types 6 and 10:** The pump motor will keep running and the electric valve will shift.
- The LCD will continue to display “AUTO” and the LCD backlight will remain turned on (will not flash on and off).

**4.1 C. If Automode is OFF (Pump types 1, 2, 3, 6, 8 and 10)**

- The LCD will display “READY” in the text area.
- The LCD will indicate system pressure as a simple pressure gauge, no additional actions will be performed regardless of previously set HI PRESS and LO PRESS values.

**4.1 D. Additional Information**

- Pressing and releasing any button on the pendant (if equipped) or shroud will stop the automatic cycle. Pressing the pendant Down-Arrow (if applicable) will also retract the cylinder. Pressing the motor On/Off button will also de-energize the motor if it is running.
- To restart the automatic cycle, press and release the pendant Up-Arrow button (if applicable) or the motor On/Off button (See section 3.1– 3.4).
- Refer to sections 6.1 through 6.5 later in this document for and detailed LCD operating instructions and descriptions of the Automode LCD screens.

## 5.0 RELIEF VALVE ADJUSTMENT

Z-Class pumps are equipped with one user adjustable relief valve (see Figure 5.)

**IMPORTANT:** To ensure proper pump operation:

- On pumps equipped with the optional pressure transducer, the relief valve must be set at least 200 psi [13.7 bar] above the HI PRESS value.
- On pumps equipped with the optional pressure switch (see section 7.0), the relief valve must be set at least 200 psi [13.7 bar] above the pressure switch setting.

To adjust the relief valve pressure setting:

1. Install a gauge on the pump.
2. If the pump is equipped with the optional pressure transducer, verify AUTOMODE is off (See section 6.5C for additional details).
3. Start the pump to allow the oil to warm.
4. Loosen the set screw locking nut.
5. Shift the control valve and build pressure in the system. Using an Allen wrench, turn the set screw counter-clockwise to decrease pressure and clockwise to increase pressure.

**Note:** To obtain an accurate setting, decrease the pressure to a point below the final setting and then slowly increase the pressure until it reaches the final setting.

6. Tighten the locking nut when the desired pressure is set.
7. Shift the control valve to the neutral position, allowing the system pressure to return to 0 psi.
8. Recheck the final pressure setting by shifting the control valve and pressurizing the system.

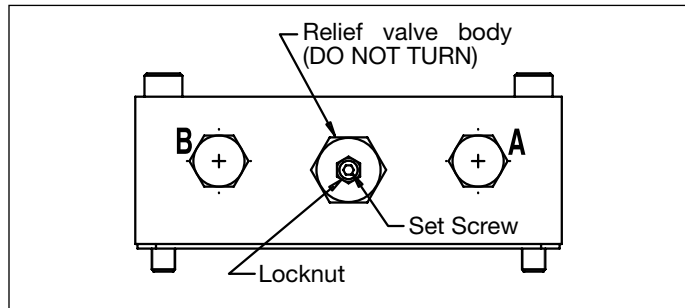

Figure 5, Relief Valve

## 6.0 LCD ELECTRONIC CONTROLS

### 6.1 LCD Control Panel Overview

The LCD control panel serves as an interface between the operator and the pump. By using the LCD control panel's four-button switches, and the additional button switches located on the pendant, all functions and settings described in sections 6.3 through 6.6 of this document can be activated.

In the event of an abnormal condition, the LCD also displays fault codes and warning alerts as described in sections 6.7 and 6.8.



**CAUTION:** Make sure that the plastic overlay that protects the LCD screen and the button switches is not broken or otherwise damaged. Never punch the button switches with a sharp or pointed instrument, use fingertips only. Clean the overlay regularly with a damp cloth. Never use aggressive or abrasive detergents.

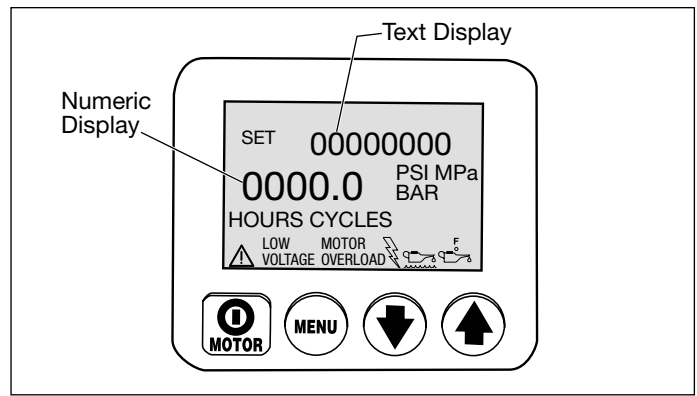

Figure 6, LCD Control Panel

### 6.2 Boot Sequence

When the pump is connected to electrical power, the LCD screen will show: "FIRMWARE 7.x" for 1 second, then "Model XX" for 0.5 seconds. Following these messages, "Motor UN", "Motor 1P" or "Motor 3P" will appear for 0.5 seconds. This information may be useful if the pump ever requires servicing or repairs. Additional information may appear, depending on pump model and installed accessories.

The boot sequence is successfully completed when the text display on the LCD screen shows "READY" (sequence takes approximately 3 seconds). On pumps equipped with the pressure transducer option, the current system pressure (typically "0" if motor is not running) will also appear on the numeric display.

### 6.3 LCD Operation Buttons

The LCD control panel is equipped with four button switches:

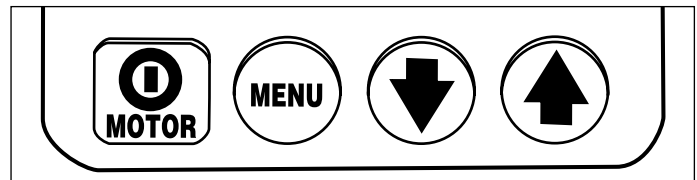

On/Off / Menu / Down Arrow / Up Arrow

- Pressing the **MOTOR** on/off button shuts-off the motor during normal operation. The motor OFF function is available on this button even if the pump is being operated by the pendant. However, the MOTOR on/off button will not turn the motor ON except if the LCD is in Local mode (See section 6.5 K).
- Pressing the **MENU** button enables the operator to step from normal operational mode into a series of menus. Repeated pressing allows the operator to step through all available menus. Pressing the Menu button also saves any changes made. To return to the normal operational mode, press and hold the Menu button for three seconds or do not push any button for 60 seconds.
- The **Down Arrow** and **Up Arrow** buttons serve two purposes. For most LCD menus, the Down Arrow and Up Arrow buttons are used to step through the menu options. Also, when the pump is placed in Local mode, pressing the Up Arrow button switches the valve solenoid on and off (the pendant is non-operational in Local mode).

## 6.4 LCD Menu Overview

The LCD contains the following available menus:

- **Normal Operation** – Default start-up screen. Appears immediately after power is connected and microcontroller has booted.

**Note:** The *Units*, *Automode*, *Hi Press* and *Lo Press* menus are available only on pumps equipped with a pressure transducer (optional equipment)

- **Units** – Sets the pressure units to PSI / BAR / MPa. PSI is the default setting.
- **Automode** – Switches the Automode function ON or OFF.
- **Hi Press** – (Available only when Automode is ON) Sets the high pressure limit at which pump de-energizes motor / electric valve.
- **Lo Press** – (Available only when Automode is ON - Not used on pump type 3) Sets the low pressure limit at which pump energizes motor / electric valve.
- **Main** – Displays pump status after the desired pump operational parameters have been input by the user and saved in the microcontroller memory.
- **Motor** – Displays the motor hour meter and on/off cycle counter (non-resettable).
- **Low Volt** – Displays the low voltage hour meter (non-resettable).
- **Advance** – Displays the solenoid hour meter and on/off cycle counter for the advance solenoid (non-resettable).
- **Retract** – Displays the solenoid hour meter and on/off cycle counter for the retract solenoid (non-resettable).
- **Local** – Switches the pump Local mode ON or OFF.
- **Language** – Sets the language of the display to English, Spanish, French, Italian, German or Portuguese, with English being the default setting.
- **Diagnose** – Displays input signals from the pendant and other electrical accessories.

## 6.5 LCD Menus

See the following paragraphs for descriptions of the LCD menus. Also refer to Table 2, Quick Reference Chart (QRC), located at the end of this document.

### 6.5A Normal Operation Menu

(See Screen 1) LCD screen “READY” indicates that the microcontroller has booted successfully.

For pumps equipped with a pressure transducer, the pressure reading will be displayed as “0” when pump is first connected to power and motor is off. Enter into the remaining menus by pressing the Menu button. Refer to QRC step #1.

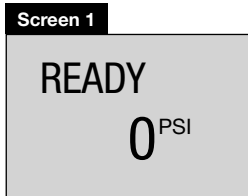

### 6.5B “Units” Menu

(See Screen 2) This screen allows the operator to set the unit of pressure measurement by pressing the Up or Down Arrow buttons. PSI, BAR and Mpa are the available choices, with PSI being the default. Save setting and step forward by pressing the Menu button. Refer to QRC step #2.

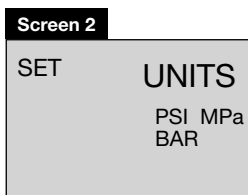

### 6.5C “Automode” Menu

(See Screen 3) This screen allows the operator to activate or de-activate automatic operation of the pump motor and electric valve (if equipped).

Toggle Automode ON or OFF by pressing either the Up or Down Arrow button. Save setting and step forward by pressing the Menu button. Refer to QRC step #3A.

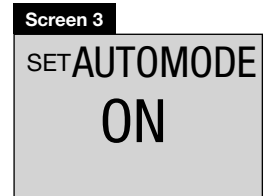

#### Notes:

- The UNITS and AUTOMODE menus are available only on pumps equipped with the pressure transducer option. These menus will not appear on pumps not equipped with a pressure transducer.
- When Automode is on, the pump will de-energize the motor / electric valve when the hydraulic pressure reaches operator defined levels. This parameter is set using the Automode “HI PRESS” menu.
- The pump can be set to re-energize the motor / electric valve when the hydraulic pressure falls to an operator defined level. This parameter is set using the Automode “LO PRESS” menu. **Note:** the LO PRESS menu is not functional for pump type 3.
- The specific operation of the motor and electric valve while Automode is activated is determined by the pump type (factory set). For additional information, refer to Table 4, Pump Model Matrix, located at the end of this document. Also refer to sections 4.0 and 4.1 for an overview of Automode operation.
- If Automode is OFF: The HI PRESS and LO PRESS menus will not be available, and any previously set HI or LO PRESS values will have no effect on pump operation.

### 6.5D “HI PRESS” Menu

(Available only when Automode is ON)

(See Screen 4) This screen allows the operator to set the high-pressure limit at which the pump de-energizes the motor / electric valve. Make changes in increments of 50 psi [3.5 bar] by pressing either Down or Up Arrow button once. Press and hold either button to scroll quickly through the available settings. Maximum pressure value is 10,500 psi [724 bar]. Save setting and step forward to the Main menu (See section 6.5F) by pressing the Menu button for 3 seconds. Refer to QRC step #3B.



**Note:** If the menu button is pressed for less than 3 seconds, the selected HI PRESS value will be saved and the LO PRESS menu (See section 6.5E) will appear.



**CAUTION:** Due to motor coast down, valve shift time and system oil capacitance, always set the user-adjustable relief valve 200 psi above the HI PRESS value to prevent pressure spikes. Refer to pump instruction sheet for relief valve setting instructions.

### 6.5E “LO PRESS” Menu (Available only when Automode is ON - All except pump type 3)

(See Screen 5) This screen allows the operator to set the low-pressure limit at which the pump energizes the motor / electric valve. Make changes in increments of 50 psi [3.5 bar] by pressing either Down or Up Arrow button once. Press and hold either button to scroll quickly through the available settings. Default pressure value is OFF (or “0” on some pump models). Save setting and step forward to the Main menu (See section 6.5F) by pressing the Menu button for 3 seconds. Refer to QRC step #3C.



**Note:** If the menu button is pressed for less than 3 seconds, the selected LO PRESS setting will be saved. However, the Motor menu (See section 6.5G) will appear instead of the Main menu.



**CAUTION:** The LO PRESS value should be set at least 400 PSI below the HI PRESS value to prevent excessive pump cycling. Use appropriate valving in the hydraulic circuit to ensure that the pump does not cycle on and off more than three times per minute. For circuits equipped with sequence valves, the LO PRESS setting should be at least as high as the first stage sequence valve pressure.

### 6.5F Main Menu

(See Screen 6A) When Automode is first turned on, the screen will display “AUTO”.

(See Screen 6B) During pump operation, and after Automode has taken control of the pump, the text will change from “AUTO” to “AUTO ON”.

**All except pump type 3:** If a LO PRESS value has been entered, the pump backlight will begin to flash on and off. This flashing will continue until system pressure drops to the LO PRESS value.

**Note:** Details of Automode operation will vary, depending on pump type and model. Refer to sections 4.0 and 4.1 for additional information. Also refer to the pump model matrix in Table 4 near the end of this document.

(See Screen 6C) If Automode is OFF, the screen will display “READY” instead of “AUTO”, and the system pressure will appear on the numeric display.

**Note:** For pumps NOT equipped with a pressure transducer, the screen will display “READY” and no pressure will be indicated. The “AUTO” and “AUTO ON” screens will not be available.

### 6.5G “Motor” Menu

(See Screen 7) This screen allows the operator to read the number of hours or on/off cycles the motor has been operated. Toggle between hours and cycles by pushing either the Down or Up Arrow button. Step forward by pressing the Menu button. Refer to QRC step #5.

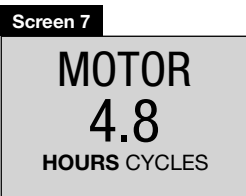

General note for all hour and cycle displays:

#### HOURS DISPLAYED

- up to 9999.9 the display will show decimal hours.
- between 10,000 - 99,999 whole hours will be displayed (decimal “.” is not displayed).
- over 99,999 hours the meter starts over at 0.0 reading decimal hours.

#### CYCLES DISPLAYED

- over 99,999 cycles the meter starts over at 0.

### 6.5H “Low Volt” Menu

(See Screen 8) This screen allows the operator to read the number of hours the pump has been operated in a low-voltage condition. Step forward by pressing the Menu button. Refer to QRC step #6.

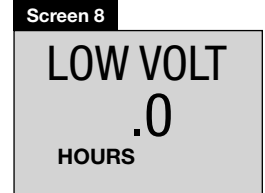

### 6.5I “Advance” Menu

(See Screen 9) This screen allows the operator to read the total number of hours that the advance valve solenoid has been operated. It also displays the total number of advance solenoid cycles. Toggle between hours and cycles by pushing either the Down or Up Arrow buttons. Step forward by pressing the Menu button. Refer to QRC step #7.

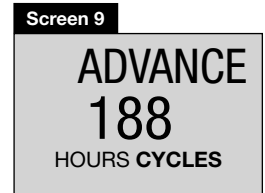

### 6.5J “Retract” Menu

(See Screen 10) This screen allows the operator to read the total number of hours that the retract solenoid has been operated. It also displays the total number of retract solenoid cycles. Toggle between hours and cycles by pushing either the Down or Up Arrow buttons. Step forward by pressing the Menu button. Refer to QRC step #8.



### 6.5K “Local” Menu

(See Screen 11) This screen allows the operator to toggle the Local mode ON or OFF (default is OFF). Local mode allows operation of the pump if the pendant or pendant cord is damaged. With Local mode ON, the shroud buttons replace the pendant buttons as the method of operating the pump, and the pendant buttons become deactivated. Toggle Local mode ON or OFF by pressing the Down or Up Arrow button. When Local mode is ON, the text “LOCAL” replaces “READY” on the “Normal Operation” menu. Save setting and step forward by pressing the Menu button. Refer to QRC step #9.

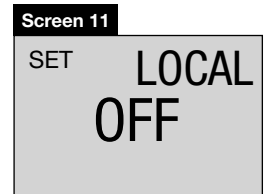

## 6.5L “Language” Menu

(See Screen 12) This screen allows the operator to change the LCD display language. When a language is shown on the LCD, press the Down or Up Arrow buttons to select a different language. Save setting and step forward by pressing the Menu button. Refer to QRC step #10.

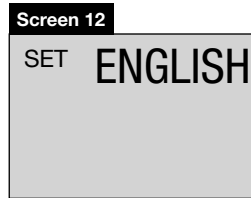

## 6.5M “Diagnose” Menu

(See Screen 13) This screen allows the operator to troubleshoot various pendant problems. If the number “1” does not appear when a pendant button is pushed, problems with the pendant button switches and/or pendant cord may be present (See Screens 14, 15 and 16). Use Local mode to operate pump until problem can be corrected. Refer to QRC step #11.

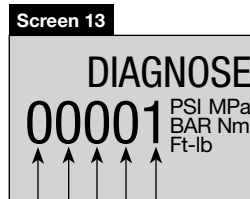

Pendant **on/off** button  
 Pendant **advance** button  
 Pendant **retract** button  
 (not used)  
 (not used)

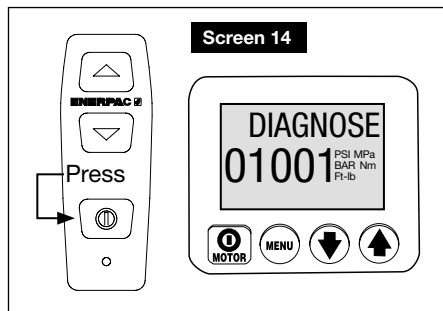

Diagnose screen with pendant **on/off** button pushed.

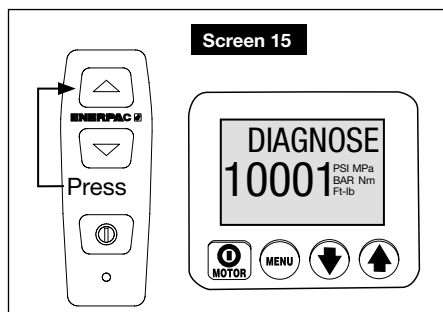

Diagnose screen with pendant **advance** button pushed.

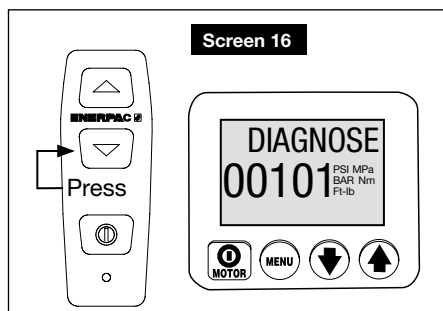

Diagnose screen with pendant **retract** button pushed.

## 6.6 LCD Hidden Menus

### 6.6A “Calibration” Menu

(See Screen 17) This screen allows the operator to adjust the pressure value shown on the LCD to match a master gauge.

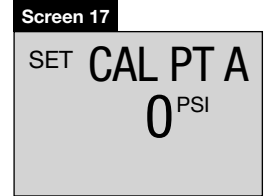

To access this menu, go to the “UNITS” menu.

Then, press and hold the shroud Motor on/off button in for 7 seconds. ENTRY CODE will appear. Then, press and hold both the Down Arrow and Up Arrow button for 7 seconds. See Table 3, “Z-Class Pressure Transducer Calibration” for adjustment steps.

### 6.7 LCD Fault Conditions

Any fault condition will shut down the pump and prevent it from starting.

#### 6.7A Clearing a Fault Condition from the LCD

After the fault causing problem has been corrected, clear the fault message from the LCD by disconnecting electrical power from the pump. Wait until all characters clear the LCD (~ 10 seconds), then reconnect power.

#### 6.7B Power Failure

Display: “POWER OFF”

(See Screen 18) The Power Off fault is displayed when the main power supply drops to 65% or less of nominal voltage. The pump will automatically shut-off the valve solenoid and the motor, and display “Power Off” on the LCD. **Note:** Power Off is also displayed for several seconds after the unit is disconnected from electrical power.

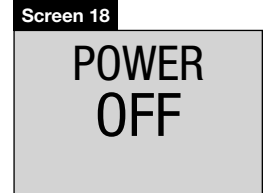

#### 6.7C Button Fault

Display: “BUTTON FAULT”

(See Screen 19) The Button Fault message is displayed when the microcontroller detects that any button is pressed during the boot sequence or if the shroud Motor on/off button is pressed for more than 3 seconds.

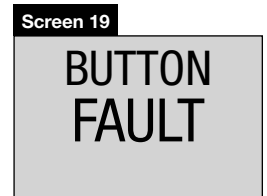

#### 6.7D Motor Overload

Display: “MTR OVLD” and “Motor Overload”

(See Screen 20) The Motor Overload fault is displayed when the electric current draw exceeds the pre-set limit of the pump’s internal circuit breaker. The circuit breaker will automatically reset in about 2 to 3 minutes after the condition has been corrected. However, before the pump can be restarted, the operator must clear the fault by disconnecting and reconnecting electrical power as described in section 5.7A.

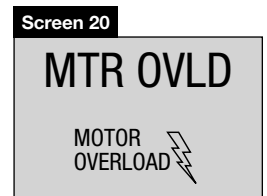

**6.7E Oil Level**  
(requires optional float / temperature switch)

**Display: "OIL LEVEL"** 

(See Screen 21) The Oil Level fault is displayed when the oil level inside the reservoir drops below 1.3" (34 mm) from bottom.

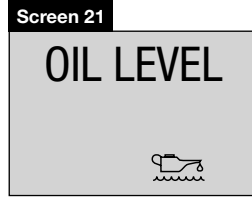

**6.7F Oil Temperature**  
(requires optional float/temperature switch)

**Display: "OIL TEMP"** 

(See Screen 22) The Oil Temperature fault is displayed when the temperature of the oil inside the reservoir exceeds 175 °F [80 °C].

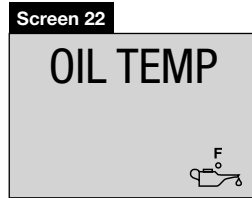

**6.7G Oil Pressure**  
(requires optional pressure switch)

**Display: "P SWITCH OPEN"**

(Screen 23) The "P SWITCH OPEN" fault is displayed when the high pressure limit is reached and the pressure switch opens.

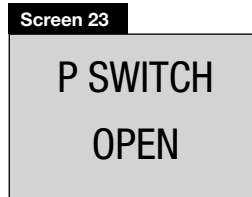

**Pressure Switch Notes:**

- The pressure switch does not provide real time pressure data to the LCD. For this reason, no pressure indication will be shown on the "READY" screen unless a pressure transducer is also installed.
  - Factory installed pressure switches are typically installed in the valve manifold "GA" port. However, if desired, the pressure switch can be installed in the valve manifold "GB" or "GP" ports.
- "GA" measures "A" port pressure.  
 "GB" measures "B" port pressure (if applicable).  
 "GP" measures pump pressure before the control valve.

**6.8 LCD Warning Conditions**

LCD Warnings notify the operator of abnormal operating conditions, but allow the pump to continue operating. Warnings will automatically clear once the abnormal condition has been resolved.

**6.8A Low Voltage Warning**

**Display: "LOW VOLT" and  "Low Voltage"**



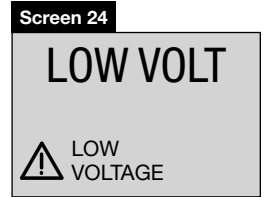

(See Screen 23) A "Low Voltage" condition is defined as an operating condition when the main power supply is at or below 80% of nominal voltage. While running the pump under this condition, the "Low Voltage" signal will flash on the LCD and the Low Voltage hours will be counted and stored by the microcontroller. Normal pump operation is still permitted.



**IMPORTANT:** Pump operation during a Low Voltage condition is not recommended. Motor RPM and hydraulic flow will be reduced. The pump's internal circuit breaker may trip due to high current draw, resulting in a Motor Overload fault (see section 6.7D).







Table 2, QRC: Quick Reference Chart • Pump Firmware Version 7.x • Pump Types 1, 2, 3, 6, 8 and 10

Step	   	Text Display	Expected reading / symbol / status digital display	Units	Comments
1		READY	0	PSI, BAR, or MPa	Firmware version 7.x, pump type (1, 2, 3, 6, 8 or 10) and motor type (UN, IP or 3P) will briefly appear on LCD. "READY" appears after power on and boot sequence has completed.
2A	X	SET UNITS		PSI	Save previous setting and step forward to select units, PSI, BAR or MPa. Default is PSI.  Save and step to #3 by pressing Menu button.
		"		BAR	
		"		MPa	
2B	X	SET UNITS	Hold for 7 Seconds		Save previous setting and step forward to select units, PSI, BAR or MPa. Default is PSI.
		"	Hold for 7 Seconds		
3A		CAL PT A	0	PSI, BAR, or MPa	Start calibration process. See Table 2, calibration reference chart for further instructions.  Toggle between "ON" and "OFF" using the Arrow buttons.
		AUTOMODE	OFF		
			ON		
3B	X				Save and step to #3B by pressing Menu button. <b>Note:</b> To step to #5 Motor screen, turn Automode OFF and press Menu button.  If Automode is ON. Set maximum pressure (upper Automode limit), default value is 10,500 psi [724 bar]. <b>Note:</b> Pressure not adjustable when Automode is OFF.
		SET HI PRESS	XXXXX (PSI, BAR or MPa)	PSI, BAR or MPa	
		"	Up 50 psi [4 bar] per 0.5 sec. for first 3 sec. Then up 50 psi [4 bar] every 0.05 sec.	"	
3C					Only if pressure transducer is detected, hold down button for 4 sec. minimum. Only if pressure transducer is detected, hold down button for 4 sec. minimum. Save and step to #3C by pressing Menu button.  If Automode is ON. Set minimum pressure (lower Automode limit), default value is OFF. <b>Note:</b> Pressure not adjustable when Automode is OFF.
		SET LO PRESS	XXXXX (PSI, BAR or MPa)	PSI, BAR or MPa	
		"	Up 50 psi [4 bar] per 0.5 sec. for first 3 sec. Then up 50 psi [4 bar] every 0.05 sec.	"	
					Only if pressure transducer is detected, hold down button for 4 sec. minimum. Only if pressure transducer is detected, hold down button for 4 sec. minimum. Save and step to #5 by pressing Menu button.
		"	Down 50 psi [4 bar] per 0.5 sec. for first 3 sec. Then down 50 psi [4 bar] every 0.05 sec.	"	
	X				

(Continued on next page)

Table 2, QRC: Quick Reference Chart • Pump Firmware Version 7.x • Pump Types 1, 2, 3, 6, 8 and 10

Step	    	Text Display	Expected reading / symbol / status digital display	Units	Comments
4		AUTO or READY	0 PSI 0 BAR 0 MPa	PSI, BAR or MPa	Text Display: "AUTO" if Automode ON "READY" if Automode OFF  Numeric display will show "0" when system pressure is zero.
5	X	MOTOR	Number of hours 0.0.	HOURS	Select hour meter function (motor).
	X	"	Number of cycles.	CYCLES	Select cycle counter function (motor).
6	X	LOW VOLT	Number of hours at low voltage, displayed as 0.0.	HOURS	Select hour meter function (low voltage condition).
7	X	ADVANCE	Number of hours, displayed as 0.0.	HOURS	Select hour meter function (solenoid advance).
	X	"	Number of cycles.	CYCLES	Select cycle counter function (solenoid advance).
8	X	RETRACT	Number of hours, displayed as 0.0.	HOURS	Select hour meter function (solenoid retract).
	X	"	Number of cycles.	CYCLES	Select cycle counter function (solenoid retract).
9	X	LOCAL	OFF		Select "LOCAL" mode. Toggle between "ON" and "OFF".
	X	"	ON		
	X	"	OFF		
10	X	ENGLISH			Select language, default is English.
	X	ESPAÑOL			
	X	FRANCAIS			
	X	ITALIANO			
	X	DEUTSCH			
	X	PORTUGUES			
	X	ENGLISH			
11	X	DIAGNOSE	00001	PSI, BAR, or MPa,	Save and step to #11 with Menu button.  Pressure or torque units will appear, indicating that pressure transducer is connected. When pendant buttons are pushed, the digital display is expected to show processor inputs that are "turned on".
			10001		With pendant On/Off button pushed.
			01001		With pendant ADVANCE button pushed.
			00101		With pendant RETRACT button pushed.
12	X	---			Hold for 3 seconds to return to step 4.

**Table 3 , Z-Class Pressure Transducer Calibration, Firmware 7.x • Pump Types 1, 2, 3, 6, 8 and 10**

No.	Operator action	LCD Reading	Comments
1	Connect a master gauge to port A (Advance port)		
2	Connect electrical power to pump.	FIRMWARE 7.x, then "READY"	Boot sequence.
3	At main screen, press the Menu button once to display "UNITS" screen.	UNITS	psi is the current unit of pressure measurement.
4	Press and hold the ON/OFF button for seven seconds.	ENTRY	Step into the hidden calibration mode.
5	Press and hold the Arrow-up and Arrow-down buttons together for seven seconds.	CAL PT A	Start of calibration process. The advance-solenoid will be powered up to access the pressure transducer through valve-port A.
6	Open the pump's user-adjustable relief valve and verify both pump LCD and master gauge read zero.	CAL PT A	Calibrate the zero-offset, point "A".
7	Press the Menu button to accept the pressure value into temporary memory.	SAVE A	
8	Press one Arrow button to change from "no" to "yes".	SAVE A	Confirm the pressure data should be stored to memory.
9	Press the Menu button once.	CAL PT B	Calibrating gain is done with two points, starting with point "B".
10	Press and release the shroud's ON/OFF motor-button to switch the pump motor on. Reading the master gauge, apply a pressure of 5000 psi by closing the pump's user-adjustable relief valve.	CAL PT B	First obtain the pressure value on the master gauge (ie 5000 psi). Then use the arrow buttons to match the LCD value to the master gauge.
11	Press the Menu button to accept the pressure value into temporary memory.	SAVE B	
12	Press one Arrow button to change from "no" to "yes".	SAVE B	Confirm the pressure data should be stored to memory.
13	Press the Menu button once.	CAL PT C	Calibrating gain is done with two points, finishing with point "C".
14	Reading the master gauge, apply a pressure of 8000 psi.	CAL PT C	First obtain the pressure value on the master gauge (ie 8000 psi). Then use the arrow buttons to match the LCD value to the master gauge.
15	Press the Menu button to accept the pressure value into temporary memory.	SAVE C	
16	Press one Arrow button to change from "no" to "yes".	SAVE C	Confirm the pressure data should be stored to memory.
17	Press the Menu button once.	USE DELT	Re-confirm calibration data. Leave "off" to proceed with new calibration data. Only set to "on" to change calibration data back to factory default settings. Press Arrow button to change.
18	Press the Menu button once.	CAL PT A	Save calibration data to permanent memory.
19	Press and hold the Menu button for three seconds to step out of the calibration mode.	READY	Calibration complete, motor stops and electric valve releases pressure.

**Table 4, Z-Class Pump Model Matrix • Firmware 7.x • Pump Types 1, 2, 3, 6, 8 and 10**

Pump Type	Pump type	Pump type code	valve	pendant	foot switch	Item	What happens when _____ button is pushed in normal operation mode ("READY" is displayed on LCD)				Operation with Automode ON Pumps Equipped with Pressure Transducer Option Only				Additional comments			
							Pendant Button	LCD Panel Button	Action when HI_PRESS value is reached	Max value for HI_PRESS	Action when LO_PRESS value is reached	Max value for LO_PRESS						
1	manual w/LCD	ZxxxxLx ZxxxxHx	any manual	none	NA	Motor & Fan (if attached)	Motor On/Off	Arrow down	Arrow up	Motor On/Off								
2	Adv / Hold / Ret	Zxx2xxSx	VE32	3-button	Option	Motor & Fan (if attached) Solenoid B	na - disabled	na - disabled pendant	na - no pendant	na - no pendant	toggle on/off	off	10,500 psi	on	50 psi less than HI_PRESS current value. 0 means LO_PRESS is turned off.			
3	Dump	Zxx1xxDx	VE32-D	1-button	Option	Motor & Fan (if attached) Solenoid A	na - disabled	na - disabled	na - disabled	momentary on (advance)	off	off	10,500 psi	na	50 psi less than HI_PRESS current value. 0 means LO_PRESS is turned off.			
6	remote 3/4-way	Zxx3xxSx Zxx4xxSx ZxxxxWx	VE33 / VE43	3-button	Option	Motor & Fan (if attached) Solenoid A	toggle on/off	no change	no change	no change	toggle on/off	when HI_PRESS is reached only the valve shuts off, motor continues running	10,500 psi	na	na	Pump type 6 is the default factory setting. 0 means LO_PRESS is turned off. Default manufacturer setting is AUTO MODE off & LO_PRESS is 0		
8	Jog	ZxxxxKx	any manual	1 or 2-button	Option	Motor & Fan (if attached)	toggle on/off	momentary on (retract)	momentary on (advance)	toggle on/off	off	off	10,500 psi	on	50 psi less than HI_PRESS current value. 0 means LO_PRESS is turned off.			

(Continued on next page)

(Continued from previous page)

Table 4, Z-Class Pump Model Matrix • Firmware 7.x • Pump Types 1, 2, 3, 6, 8 and 10

Pump Type.	Pump type	Pump type code	valve	pendant	foot switch	Item	What happens when _____ button is pushed in normal operation mode ("READY" is displayed on LCD)			Operation with Automode ON				Additional comments
							Pendant Button	LCD Panel Button	Max value for HI_PRESS	Action when HI_PRESS (SET_PRESS) value is reached	Max value for LO_PRESS	Action when LO_PRESS value is reached	Max value for LO_PRESS	
10	Manual Momentary Pump	ZxxxxxWx	VE33 / VE43	3-button	Option	Motor & Fan (if attached)	Motor On/Off	Motor On/Off	toggle on/off (see note 1)	10,500 psi	na	na	na	Similar to pump No. 6 except that LOCAL MODE is the default at start-up. Pendant buttons are disabled. (See Note 2)
			none	none		Solenoid A	Motor On/Off	Motor On/Off	momentary on (advance) Note: Motor may be on or off		off	off	50 psi less than HI_PRESS current value. 0 means LO_PRESS is turned off	
						Solenoid B	Motor On/Off	Motor On/Off	momentary on (retract) Note: Motor may be on or off		off	off	na	

**Notes - Pump Type 10:**

1. If Automode is OFF, motor is momentary on (no toggle).
2. If Automode is OFF, solenoids can be operated manually when motor is off or on.

## Enerpac Worldwide Locations

### Africa

ENERPAC Middle East FZE  
Office 423, JAFZA 15  
P.O. Box 18004  
Jebel Ali, Dubai  
United Arab Emirates  
Tel: +971 (0)4 8872686  
Fax: +971 (0)4 8872687

### Australia, New Zealand

Actuant Australia Ltd.  
Block V Unit 3  
Regents Park Estate  
391 Park Road  
Regents Park NSW 2143  
(P.O. Box 261) Australia  
Tel: +61 297 438 988  
Fax: +61 297 438 648

### Brazil

Power Packer do Brasil Ltda.  
Rua dos Inocentes, 587  
04764-050 - Sao Paulo (SP)  
Tel: +55 11 5687 2211  
Fax: +55 11 5686 5583  
**Toll Free in Brazil:**  
Tel: 0800 891 5770  
vendasbrasil@enerpac.com

### Canada

Actuant Canada Corporation  
6615 Ordan Drive, Unit 14-15  
Mississauga, Ontario L5T 1X2  
Tel: +1 905 564 5749  
Fax: +1 905 564 0305  
**Toll Free:**  
Tel: +1 800 268 4987  
Fax: +1 800 461 2456  
**Technical Inquiries:**  
techservices@enerpac.com

### China

Actuant Industries Co. Ltd.  
No. 6 Nanjing Road  
Taicang Economic Dep Zone  
Jiangsu, China  
Tel: +86 0512 5328 7529  
+86 0512 5328 7500 7529  
Fax: +86 0512 5335 9690

### Actuant China Ltd. (Beijing)

709B Diyang Building  
Xin No. 2  
Dong San Huan North Rd.  
Beijing City  
100028 China  
Tel: +86 10 845 36166  
Fax: +86 10 845 36220

### Central and Eastern Europe, Greece

ENERPAC GmbH  
P.O. Box 300113  
D-40401 Düsseldorf  
Willstätterstrasse13  
D-40549 Düsseldorf  
Germany  
Tel: +49 211 471 490  
Fax: +49 211 471 49 28

### France, Switzerland francophone

ACTUANT - ENERPAC  
France S.A., ZA de Courtaboeuf  
32, avenue de la Baltique  
91140 Villebon / Yvette  
France  
Tel: +33 1 60 13 68 68  
Fax: +33 1 69 20 37 50

### Germany, Austria and Switzerland and Baltic States

ENERPAC GmbH  
P.O. Box 300113  
D-40401 Düsseldorf  
Willstätterstrasse13  
D-40549 Düsseldorf  
Germany  
Tel: +49 211 471 490  
Fax: +49 211 471 49 28

### India

ENERPAC Hydraulics  
(India) Pvt. Ltd.  
No. 1A,  
Peenya Industrial Area,  
IInd Phase  
Bangalore, 560 058 India  
Tel: +91 80 40 792 777  
Fax: +91 80 40 792 792

### Italy

ENERPAC S.p.A.  
Via Canova 4  
20094 Corsico (Milano)  
Tel: +39 02 4861 111  
Fax: +39 02 4860 1288

### Japan

Applied Power Japan LTD KK  
Besshochou 85-7  
Kita-ku,  
Saitama-shi 331-0821  
Japan  
Tel: +81 48 662 4911  
Fax: +81 48 662 4955

### Middle East, Turkey and Caspian Sea

ENERPAC Middle East FZE  
Office 423, JAFZA 15  
P.O. Box 18004  
Jebel Ali, Dubai  
United Arab Emirates  
Tel: +971 (0)4 8872686  
Fax: +971 (0)4 8872687

### Russia and CIS (excl. Caspian Sea Countries)

Actuant LLC  
Admiral Makarov Street 8  
125212 Moscow, Russia  
Tel: +7-495-9809091  
Fax: +7-495-9809092

### Sweden, Denmark, Norway, Finland and Iceland

ENERPAC Scandinavia AB  
Fabriksgatan 7  
412 50 Gothenburg  
Sweden  
Tel: +46 31 7990281  
Fax: +46 31 7990010

### Singapore

Actuant Asia Pte. Ltd.  
37C, Benoi Road Pioneer Lot,  
Singapore 627796  
Tel: +65 68 63 0611  
Fax: +65 64 84 5669  
**Toll Free:** +1800 363 7722  
**Technical Inquiries:**  
techsupport@enerpac.com.sg

### South Korea

Actuant Korea Ltd.  
3Ba 717,  
Shihwa Industrial Complex  
Jungwang-Dong, Shihung-Shi, Kyunggi-Do  
Republic of Korea 429-450  
Tel: +82 31 434 4506  
Fax: +82 31 434 4507

### Spain and Portugal

ENERPAC SPAIN, S.L.  
Avda. Los Frailes, 40 - Nave C & D  
Pol. Ind. Los Frailes  
28814 DAGANZO DE ARRIBA (Madrid)  
Spain  
Tel: +34 91 661 11 25  
Fax: +34 91 661 47 89

◆ **internet:** [www.enerpac.com](http://www.enerpac.com)

### The Netherlands, Belgium, Luxembourg

ENERPAC B.V.  
Galvanistraat 115, 6716 AE Ede  
P.O. Box 8097, 6710 AB Ede  
The Netherlands  
Tel: +31 318 535 800  
Fax: +31 318 525 613  
+31 318 535 848

**Technical Inquiries Europe:**  
techsupport.europe@enerpac.com

### United Kingdom, Ireland

Enerpac Ltd  
Bentley Road South  
Darlaston, West Midlands  
WS10 8LQ, United Kingdom  
Tel: +44 (0)121 50 50 787  
Fax: +44 (0)121 50 50 799

### USA, Latin America and Caribbean

ENERPAC  
P.O. Box 3241  
6100 N. Baker Road  
Milwaukee, WI 53209 USA  
Tel: +1 262 781 6600  
Fax: +1 262 783 9562

### User inquiries:

+1 800 433 2766

### Inquiries/orders:

+1 800 558 0530

### Technical Inquiries:

techservices@enerpac.com

ENERPAC  
704 W. Simonds  
Dallas, TX 75159 USA  
Tel: +1 972 287 2390  
Fax: +1 972 287 4469