

**Enerpac's Bolting Solutions cater to the complete bolting work-flow, ensuring joint integrity in a variety of applications throughout the industry:**

### Joint Assembly

From simple pipe alignment to complex joint positioning of large structural assemblies, our comprehensive line of joint assembly products range from hydraulic and mechanical alignment tools to synchronized PLC-controlled multi-point positioning systems.

### Controlled Tightening

Enerpac offers a variety of controlled tightening options to best meet the requirements of your application. From mechanical torque multipliers to hydraulic, pneumatic and electric square drive wrenches and from low profile torque wrenches to interconnectable bolt tensioning tools; we offer the products you need for accurate and simultaneous tightening of multiple bolts.

### Joint Separation

Enerpac also provides hydraulic nut splitters and a variety of mechanical and hydraulic spreading tools for joint separation during inspection, maintenance and decommissioning operations.

High quality bolting solutions from the brand you can trust.

See how Enerpac can make your bolting work-flow more accurate, safer and efficient.



### Bolting Integrity Software

Visit [www.enerpac.com](http://www.enerpac.com) to access our free on-line bolting software application and obtain information on tool selection, bolt load calculations and tool pressure settings. A combined application data sheet and joint completion report is also available.























### Torque Tightening and Tensioning

See our 'Yellow Pages' for information on Bolting Theory. See our Bolting Safety Instructions on [www.enerpac.com](http://www.enerpac.com)

Page: **265**



# Bolting Tools & Pumps Section Overview

Applications	Capacity	Tool type and functions	Series	Page	
Controlled Tightening and Loosening	1015 - 10.845 Nm 750 - 8000 Ft.lbs	<b>Manual Torque Multipliers</b>	E		184 ▶
	1952 - 35.455 Nm 1440 - 26.150 Ft.lbs	<b>Square Drive Hydraulic Torque Wrenches</b> Rigid steel design & maximum versatility	S		186 ▶
	19 - 155 mm ¾ - 6⅞ inch	<b>Heavy-Duty Impact Sockets</b> Square drive	BSH		190 ▶
	2766 - 47.454 Nm 2040 - 35.000 Ft.lbs	<b>Hexagon Hydraulic Torque Wrenches</b> <b>Ultra-Slim Stepped Width Cassettes</b>	W W-SL		192 ▶ 202 ▶
	5762 Nm 4250 Ft.lbs	<b>Roller Cassette Torque Wrench</b> Versatile high performance limited access tools	WCR		204 ▶
	1356 - 8135 Nm 1000 - 6000 Ft.lbs	<b>Pneumatic Torque Wrenches</b> <b>Electric Torque Wrenches</b>	PTW ETW		206 ▶ 208 ▶
		<b>Selection Matrix</b> Torque Wrenches - Pumps - Hoses			212 ▶
	Flow: 0,34 l/min Power: 0,37 kW	<b>Portable Electric Torque Wrench Pumps</b> Compact Economy	PME PMU		213 ▶
	Flow: 0,50 l/min Power: 0,75 kW	<b>Electric Torque Wrench Pumps</b> Lightweight	TQ		214 ▶
	Flow: 0,90 l/min Power: 1,25 kW	<b>Portable Electric Torque Wrench Pumps</b> Z-Class innovation	ZU4T		216 ▶
	Flow: 0,82-1,64 l/min Power: 1,1 - 2,2 kW	<b>Electric Torque Wrench Pumps</b> Z-Class innovation	ZE4T ZE5T		220 ▶
	Flow: 0,90 l/min Air: 2840 l/min	<b>Air Driven Torque Wrench Pumps</b> Z-Class innovation	ZA4T		222 ▶
	2845 kN 639,5 klf	<b>Hydraulic Bolt Tensioners</b>	GT		226 ▶
	Flow: 0,13 l/min Power: 1,25 kW	<b>Electric Tensioning Pumps &amp; Accessories</b> Z-Class Tensioning pumps upto 1500 bar	ZUTP		228 ▶
	Flow: 0,61 cm <sup>3</sup> /stroke	<b>High Pressure Hand Pump and Accessories</b> Hand Pump, Hoses and Couplers upto 1500 bar	HPT HT, B		229 ▶
	Flow: 0,07 l/min Air: 590 l/min	<b>Ultra-High Pressure Air Pump</b> Upto 1500 bar	ATP		230 ▶
Joint Assembly and Joint Separation	10 - 75 mm hexagon 70 - 130 mm hexagon	<b>Hydraulic Nut Cutters</b> Single and Dual-Blade Models	NC NS		231 ▶ 232 ▶
	5 - 14 ton (45 - 125 kN)	<b>Pin-type Hydraulic Flange Spreaders</b> <b>Step-type Industrial Spreaders</b>	FS FSH, FSM		234 ▶ 235 ▶
	1 - 9 ton (10 - 90 kN)	<b>Flange Alignment Tools</b> Mechanical and Hydraulic	ATM		236 ▶
	Ø 1 - 12 inch flanges	<b>QuickFace – Mechanical Pipe Flange Face Tool</b> Refacing of flat pipe flange surfaces	FF		238 ▶

▼ Shown from left to right: E291, E393, E494



- High-efficiency planetary gear sets achieve high output torque from low input torque
- Operator protected by anti-backlash device
- Torque multiplier accuracy  $\pm 5\%$
- Reversible, tighten or loosen bolts
- Reaction bar or reaction plate style
- Angle-of-turn protractor standard on E300-Series models
- Reaction plate models offer increased versatility with reaction point locations
- E300 and E400-Series have replaceable shear drives, providing overload protection of internal power train
- One replacement shear drive is included with each E300 and E400-Series models.

## Accurate, Efficient Torque Multiplication

When accurate make-up or break-out of stubborn fasteners requires high torque



### Typical Torque Multiplier Applications

- Locomotives
- Power plants
- Pulp and paper mills
- Refineries
- Chemical plants
- Mining and construction
- Off-road equipment
- Shipyards
- Cranes.



◀ Enerpac Reaction Bar Torque Multiplier E393 used to manually torque bolts up to 4300 Nm.

### ▼ SELECTION CHART

Torque Multiplier Type	Nominal Output Torque		Model Number
	(Nm)	(Ft.lbs)	
Reaction Bar Multiplier	1015	750	E290PLUS
	1355	1000	E291
	1625	1200	E391
	2980	2200	E392
	4340	3200	E393
Reaction Plate Multiplier	2980	2200	E492
	4340	3200	E493
	6780	5000	E494
	10845	8000	E495



## Manual Torque Multipliers

Enerpac manual torque multipliers provide efficient torque multiplication in wide clearance applications and when external power sources are not available.

Manual torque multipliers are used in most industrial, construction, and equipment maintenance applications. Hydraulic torque wrenches are better suited for tight tolerance, flange and repetitive bolting applications.

### Use Reaction Bar Models:

- Where space is limited,
- Where multiple reaction points are available,
- when portability is desirable.

### Use Reaction Plate Models:

- Above 4300 Nm output torque,
- On flanges and applications where neighbouring bolt or nut is available to react against
- When extreme reaction forces are generated.

## E Series



Nominal Output Torque:

**1015 - 10.845 Nm**

Torque Ratio:

**3:1 - 52:1**

Output Ratio Accuracy:

**± 5 %**



### CAUTION!

Never use impact air tools for power driving torque multipliers. Torque multiplier drive train damage will occur.

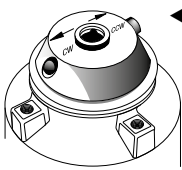

### Selector Pawl

Models with anti-backlash protection have directional selector pawls. Set the pawl for clockwise or counter-clockwise rotation.

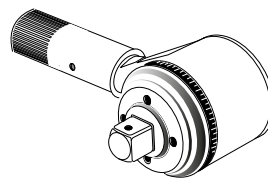

### Angle-of-Turn Protractor

E391, E392 and E393 models include an angle-of-turn protractor (scale) to tighten fasteners using a "torque turn" method. Allows accurate measuring a specific number of degrees of rotation.

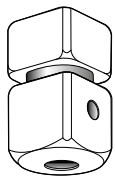

### Shearable Square Drive

Provides overload protection on E300- and E400-series multiplier's power train by shearing when the rated capacity of the tool is exceeded. Internal shear pin prevents tool from falling off bolt.

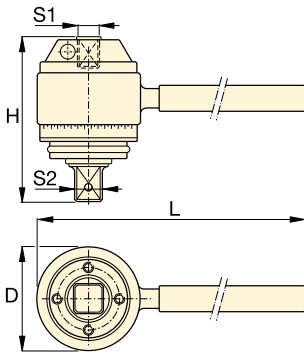

Reaction Bar Type <sup>1)</sup>

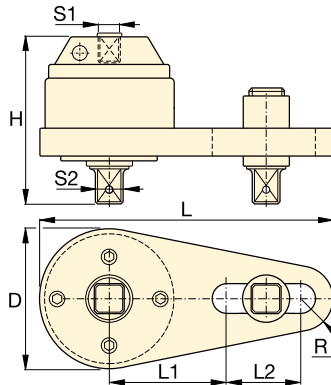

Reaction Plate Type <sup>1)</sup>



### Torque Wrenches

Enerpac offers a complete range of hydraulic, pneumatic and electric torque wrenches.

Page: 183



### BSH-Series Sockets

Heavy-Duty Impact Sockets for power driven torqueing equipment.

Page: 190

Input Torque <sup>2)</sup>	Torque Ratio	Input Female Square Drive	Output Male Square Drive		Over-load protection	Anti-Backlash	Dimensions (mm)						Model Number	
			S2 (inch)	Replaceable Shear Drive Model Nr.			D	H	L	L1	L2	R		
338 (Nm) / 250 (Ft.lbs)	3 : 1	1/2 (inch)	3/4 (inch)	-	No	No	71	84	218	-	-	-	1,8 (kg)	E290PLUS
451 (Nm) / 333 (Ft.lbs)	3 : 1	1/2 (inch)	3/4 (inch)	-	No	No	71	84	442	-	-	-	2,5 (kg)	E291
271 (Nm) / 200 (Ft.lbs)	6 : 1	1/2 (inch)	3/4 (inch)	E391SDK	Yes	No	100	102	498	-	-	-	6,3 (kg)	E391
219 (Nm) / 162 (Ft.lbs)	13,6 : 1	1/2 (inch)	1 (inch)	E392SDK	Yes	Yes	103	146	498	-	-	-	6,9 (kg)	E392
234 (Nm) / 173 (Ft.lbs)	18,5 : 1	1/2 (inch)	1 (inch)	E393SDK	Yes	Yes	103	165	498	-	-	-	8,3 (kg)	E393
219 (Nm) / 162 (Ft.lbs)	13,6 : 1	1/2 (inch)	1 (inch)	E392SDK	Yes	Yes	124	140	356	140	124	32	7,8 (kg)	E492
234 (Nm) / 173 (Ft.lbs)	18,5 : 1	1/2 (inch)	1 (inch)	E393SDK	Yes	Yes	124	163	356	140	124	32	10,6 (kg)	E493
256 (Nm) / 189 (Ft.lbs)	26,5 : 1	1/2 (inch)	1 1/2 (inch)	E494SDK	Yes	Yes	143	222	378	178	89	42	15,4 (kg)	E494
208 (Nm) / 154 (Ft.lbs)	52 : 1	1/2 (inch)	1 1/2 (inch)	E495SDK	Yes	Yes	148	273	386	178	89	48	22,8 (kg)	E495

<sup>1)</sup> E200 and E400-series do not have an Angle-of-Turn Protractor (scale).

<sup>2)</sup> User must verify manual torque wrench accuracy prior to use to ensure accurate final output torque.

▼ Shown: S3000PX



## Setting New Standards in Safety, Simplicity and Performance



### Two Handle Styles

Robust angled positioning handle comes standard with every S-Series (X-Edition) tool. Straight positioning handles are available as accessories.

Compatible S-Series (X-Edition) wrenches	Model Nr. Angled positioning handles (standard)	Model Nr. Straight positioning handles (optional)
S1500PX, S3000PX	<b>SWH6A</b>	<b>SWH6S</b>
S6000PX, S11000PX	<b>SWH10A</b>	<b>SWH10S</b>
S25000PX	<b>SWH10EA</b> <sup>2)</sup>	

<sup>2)</sup> SWH10EA is an eyebolt handle.

### Safety and Performance

- Compact, high-strength uni-body construction provides a small operating radius without sacrificing endurance
- 35° rotation angle and rapid return stroke for fast operation
- Tough manifold design with added safety feature for enhanced operator safety

### Simplicity

- 360° click-on reaction arm with quick release lever provides easier handling, even with gloves on
- Includes robust handle which mounts on both sides of tool for extra maneuverability
- Push button square drive release for quickly reversing the square drive for tightening or loosening

### Versatility

- Enhanced tilt and swivel TSP300 manifold for horizontal and vertical maneuverability, with greater durability <sup>1)</sup>

### Accuracy

- Constant torque output provides accuracy of  $\pm 3\%$  across full stroke
- Optional Angle-of-Turn Indicator provides measurement of rotation.



### TSP300 Tilt & swivel manifold

Standard TSP300 tilt and swivel manifold with robust interlocking design provides 360° X-axis rotation and 160° Y-axis rotation.

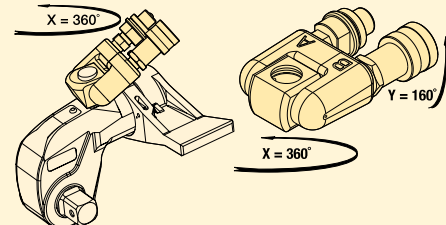

### ATEX declared. Calibration certificate included

All X-edition tools are CE - ATEX declared and are shipped complete with a calibration certificate.



<sup>1)</sup> TSP300 is designed for X-Edition tools only, and is not compatible with previous edition tools. For replacement components for existing tools, refer to repair sheet on [www.enerpac.com](http://www.enerpac.com)

# X-Edition, Square Drive Torque Wrenches

Standard are: ① ② ④ ⑥ ⑧  
Other items are optional.

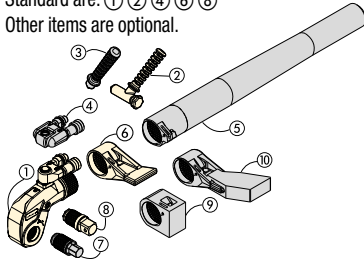

- ① Drive Unit
- ② Angeled Positioning Handle
- ③ Straight Positioning Handle
- ④ Pro Series Swivel
- ⑤ Reaction Tube Extension
- ⑥ Standard Reaction Arm
- ⑦ Allen Drive
- ⑧ Square Drive
- ⑨ Short Reaction Arm
- ⑩ Extended Reaction Arm

**Select the Right Torque**  
Choose your Enerpac Torque Wrench using the untightening rule of thumb:  
Loosening torque equals about 250% of tightening torque.

## S Series X-Edition



Nominal Torque Output:  
**35.455 Nm**

Square Drive Range:  
**3/4 - 2 1/2 inch**

Nose Radius:  
**25 - 64 mm**

Maximum Operating Pressure:  
**690 bar**

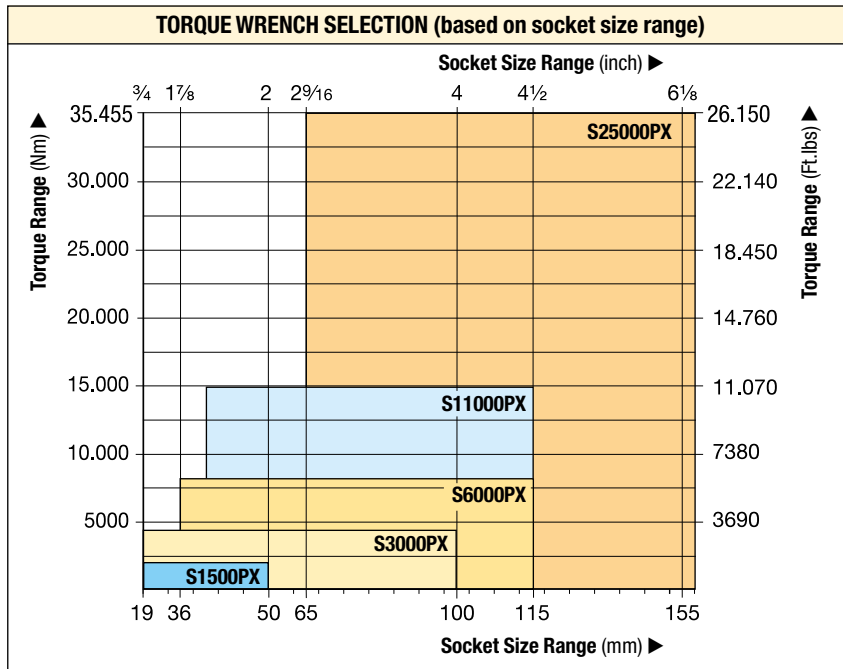

**Use only Heavy Duty Impact Sockets**  
For power driven torquing equipment, according to ISO2725 and ISO1174; DIN 3129 and DIN 3121 or ASME-B107.2/1995.

*Page:* **190**

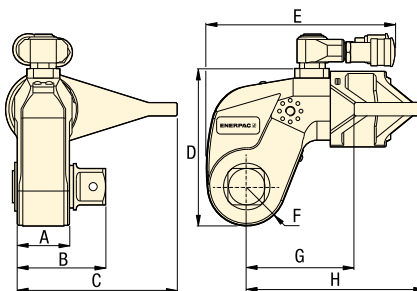

**Accessory Options**  
A full list of optional accessories is available for maximum versatility.

*Page:* **189**

▼ The rigid steel design of the S-Series torque wrenches provides durability, reliability and safety.



Nominal Torque at 690 bar		Minimum Torque at 69 bar		Square Drive Size (inch)		Angle-of-Turn Model Nr. (optional)	Torque Wrench Model Number *	Dimensions (mm)								Weight (kg)
(Nm)	(Ft.lbs)	(Nm)	(Ft.lbs)	Model Nr. (included with wrench)	Model Nr. (optional)			A	B	C	D	E	F	G	H	
1952	1440	195	144	3/4	SD15-012	AOT15	<b>S1500PX</b>	39	65	108	97	136	25	70	129	3,2
4373	3225	438	323	1	SD30-100	AOT30	<b>S3000PX</b>	48	78	135	128	173	33	90	161	5,6
8338	6150	834	615	1 1/2	SD60-108	AOT60	<b>S6000PX</b>	55	92	169	157	192	40	110	188	9,2
15.151	11.175	1516	1118	1 1/2	SD110-108	AOT110	<b>S11000PX</b>	72	114	197	190	228	50	133	229	15,8
35.455	26.150	3545	2615	2 1/2	SD250-208	AOT250	<b>S25000PX</b>	89	143	246	244	287	64	182	295	32,2

\* To order a S-Series (X-edition) torque wrench without a TSP300 tilt and swivel manifold, remove "P" prior to the "X" in the tool model number, example: **S1500X**.

Maximum Torque at 690 bar:

**35.455 Nm**

Hexagon Size Allen Drive:

**½ - 2¼ inch**

Hexagon Size Allen Drive:

**14 - 85 mm**

For  
**S**  
Series

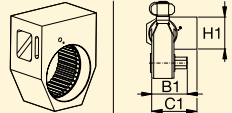

Torque Wrench 	Optional Allen Drives, Imperial				Optional Allen Drives, Metric				Short Reaction Arm for Allen Drives 		
	Hexagon Size <sup>1)</sup> (inch)	Maximum Torque (Nm)	Model Number	Dim. B1 (mm)	Hexagon Size <sup>1)</sup> (mm)	Maximum Torque (Nm)	Model Number	Dim. B1 (mm)	Model Number	Dimensions (mm) C1   H1	
<b>S1500PX</b> (1952 Nm)	½	481	<b>SDA15-008</b>	66	<b>14</b>	644	<b>SDA15-14</b>	66	<b>SRA15X</b>	67,5	74
	5/8	936	<b>SDA15-010</b>	67	<b>17</b>	1152	<b>SDA15-17</b>	68			
	¾	1620	<b>SDA15-012</b>	71	<b>19</b>	1607	<b>SDA15-19</b>	70			
	7/8	1952	<b>SDA15-014</b>	74	<b>22</b>	1952	<b>SDA15-22</b>	73			
	<b>1</b>	1952	<b>SDA15-100</b>	77	<b>24</b>	1952	<b>SDA15-24</b>	74			
<b>S3000PX</b> (4373 Nm)	5/8	936	<b>SDA30-010</b>	77	<b>17</b>	1152	<b>SDA30-17</b>	77	<b>SRA30X</b>	80,0	74
	¾	1620	<b>SDA30-012</b>	80	<b>19</b>	1607	<b>SDA30-19</b>	79			
	7/8	2569	<b>SDA30-014</b>	83	<b>22</b>	2488	<b>SDA30-22</b>	82			
	<b>1</b>	3830	<b>SDA30-100</b>	86	<b>24</b>	3234	<b>SDA30-24</b>	84			
	<b>1 1/8</b>	4373	<b>SDA30-102</b>	88	<b>27</b>	4373	<b>SDA30-27</b>	85			
	<b>1 1/4</b>	4373	<b>SDA30-104</b>	89	<b>30</b>	4373	<b>SDA30-30</b>	87			
	-	-	-	-	<b>32</b>	4373	<b>SDA30-32</b>	88			
<b>S6000PX</b> (8338 Nm)	5/8	936	<b>SDA60-010</b>	85	<b>17</b>	1152	<b>SDA60-17</b>	86	<b>SRA60X</b>	91,5	89
	¾	1620	<b>SDA60-012</b>	89	<b>19</b>	1607	<b>SDA60-19</b>	88			
	7/8	2569	<b>SDA60-014</b>	92	<b>22</b>	2488	<b>SDA60-22</b>	91			
	<b>1</b>	3830	<b>SDA60-100</b>	95	<b>24</b>	3234	<b>SDA60-24</b>	93			
	<b>1 1/8</b>	5457	<b>SDA60-102</b>	97	<b>27</b>	4603	<b>SDA60-27</b>	94			
	<b>1 1/4</b>	7484	<b>SDA60-104</b>	98	<b>30</b>	6311	<b>SDA60-30</b>	96			
	-	-	-	-	<b>32</b>	7660	<b>SDA60-32</b>	97			
<b>S11000PX</b> (15.151 Nm)	<b>1 1/4</b>	7484	<b>SDA110-104</b>	115	<b>30</b>	6311	<b>SDA110-30</b>	112	<b>SRA110X</b>	127,5	106
	<b>1 3/8</b>	9958	<b>SDA110-106</b>	117	<b>32</b>	7660	<b>SDA110-32</b>	114			
	<b>1 1/2</b>	12.928	<b>SDA110-108</b>	118	<b>36</b>	10.901	<b>SDA110-36</b>	117			
	<b>1 5/8</b>	15.151	<b>SDA110-110</b>	122	<b>41</b>	15.151	<b>SDA110-41</b>	121			
	<b>1 3/4</b>	15.151	<b>SDA110-112</b>	125	<b>46</b>	15.151	<b>SDA110-46</b>	127			
<b>S25000PX</b> (35.455 Nm)	<b>1 1/2</b>	12.928	<b>SDA250-108</b>	141	<b>36</b>	10.901	<b>SDA250-36</b>	140	<b>SRA250X</b>	158,5	135
	<b>1 5/8</b>	16.433	<b>SDA250-110</b>	145	<b>41</b>	16.107	<b>SDA250-41</b>	144			
	<b>1 3/4</b>	20.520	<b>SDA250-112</b>	148	<b>46</b>	22.744	<b>SDA250-46</b>	148			
	<b>1 7/8</b>	25.245	<b>SDA250-114</b>	149	<b>50</b>	29.211	<b>SDA250-50</b>	151			
	<b>2</b>	30.635	<b>SDA250-200</b>	151	<b>55</b>	35.455	<b>SDA250-55</b>	154			
	<b>2 1/4</b>	35.455	<b>SDA250-204</b>	154	<b>60</b>	35.455	<b>SDA250-60</b>	158			
	-	-	-	-	<b>65</b>	35.455	<b>SDA250-65</b>	161			
	-	-	-	-	<b>70</b>	35.455	<b>SDA250-70</b>	164			
	-	-	-	-	<b>75</b>	35.455	<b>SDA250-75</b>	168			
	-	-	-	-	<b>85</b>	35.455	<b>SDA250-85</b>	175			

<sup>1)</sup> See page 277 for table of hexagon sizes of bolts, nuts and related thread diameters.

# Accessories for S-Series, X-Edition Wrenches

Standard are: ① ② ④ ⑥ ⑧  
Other items are optional.

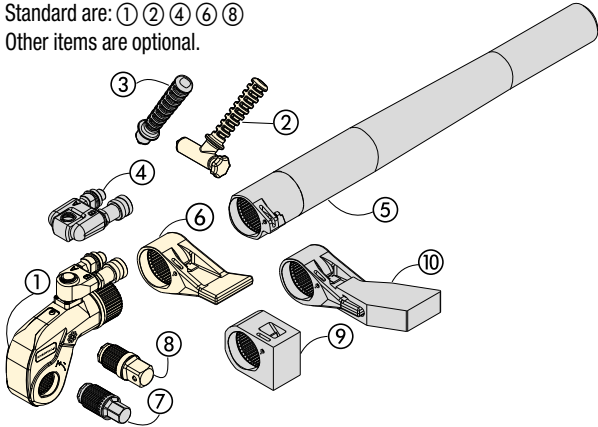

- ① Drive Unit
- ② Angeled Positioning Handle
- ③ Straight Positioning Handle
- ④ Pro Series Swivel
- ⑤ Reaction Tube Extension
- ⑥ Standard Reaction Arm
- ⑦ Allen Drive
- ⑧ Square Drive
- ⑨ Short Reaction Arm
- ⑩ Extended Reaction Arm

**RTEX**  
**SRSX**  
for  
**S**  
Series



## RTEX-Series, Reaction Tube Extensions

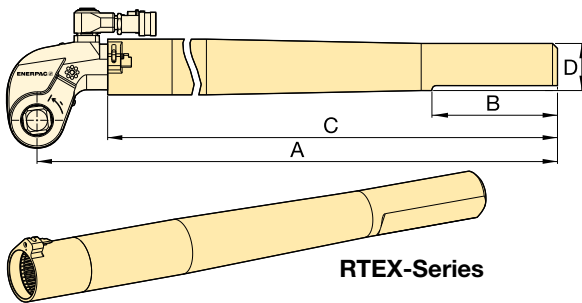

- Full torque rated
- Increases tool fit in restricted access areas

For Torque Wrench Model Number	Model Number	Dimensions (mm)				Weight (kg) *
		A	B	C	D	
S1500PX	RTE15X	706	152	636	58	4,6
S3000PX	RTE30X	733	152	647	57	5,5
S6000PX	RTE60X	747	152	659	65	7,7
S11000PX	RTE110X	769	152	675	76	11,2
S25000PX	RTE250X	813	152	685	100	17,3

\* Weights indicated are for the accessories only and do not include the wrench.

## SRSX-Series, Extended Reaction Arms

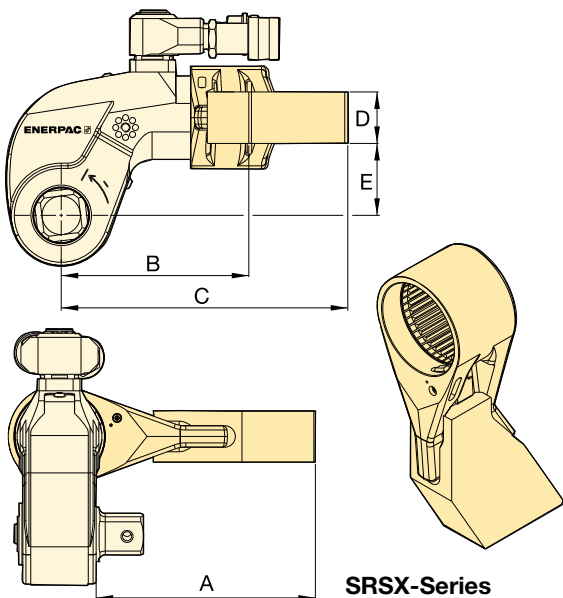

- Lightweight interchangeable design

For Wrench Model	Max. Torque (Nm)	Model Number	Dimensions (mm)					Weight (kg) *
			A	B	C	D	E	
S1500PX	1801	SRS151X	94	86	127	24	34	0,8
	1641	SRS152X	119	97	138	24	34	1,0
	1533	SRS153X	145	109	148	24	34	1,2
S3000PX	3918	SRS301X	111	106	168	34	48	1,6
	3712	SRS302X	137	117	182	34	48	2,0
	3574	SRS303X	162	132	198	34	48	2,5
S6000PX	7842	SRS601X	138	128	192	39	62	2,3
	7454	SRS602X	163	144	207	39	62	2,7
	7175	SRS603X	189	159	222	39	62	3,4
S11000PX	14.650	SRS1101X	149	157	232	46	76	4,4
	13.957	SRS1102X	175	172	247	46	76	5,1
	13.391	SRS1103X	200	187	261	46	76	5,8
S25000PX	33.538	SRS2501X	183	209	295	50	100	7,6
	32.049	SRS2502X	208	222	310	50	100	8,4
	30.750	SRS2503X	233	236	326	50	100	10,0

\* Weights indicated are for the accessories only and do not include the wrench.



# BSH-Series, Heavy-Duty Sockets

- Heavy-duty impact sockets
- Supplied with "Pin and Ring"

## METRIC SOCKETS

¾" Square Drive		1" Square Drive		1½" Square Drive		2½" Square Drive	
Model Number	A/F (mm)	Model Number	A/F (mm)	Model Number	A/F (mm)	Model Number	A/F (mm)
BSH7519	19	BSH1019	19	BSH1536	36	BSH2565	65
BSH7524	24	BSH1024	24	BSH15163	41	BSH2570	70
BSH7527	27	BSH1027	27	BSH1546	46	BSH2575	75
BSH7530	30	BSH1030	30	BSH1550	50	BSH2580	80
BSH7532	32	BSH1032	32	BSH1555	55	BSH2585	85
BSH7536	36	BSH1036	36	BSH1560	60	BSH2590	90
BSH75163	41	BSH10163	41	BSH1565	65	BSH2595	95
BSH7546	46	BSH1046	46	BSH1570	70	BSH25100	100
BSH7550	50	BSH1050	50	BSH1575	75	BSH25105	105
-	-	BSH1055	55	BSH1580	80	BSH25110	110
-	-	BSH1060	60	BSH1585	85	BSH25115	115
-	-	BSH1065	65	BSH1590	90	BSH25120	120
-	-	BSH1070	70	BSH1595	95	BSH25125	125
-	-	BSH1075	75	BSH15100	100	BSH25135	135
-	-	BSH1080	80	BSH15105	105	BSH25140	140
-	-	BSH1085	85	BSH15110	110	BSH25145	145
-	-	BSH1090	90	BSH15115	115	BSH25150	150
-	-	BSH1095	95	-	-	BSH25155	155
-	-	BSH10100	100	-	-	-	-

## BSH Series



Hexagon Size:

**19 - 155 mm | ¾" - 6 1/8"**



### Select the Right Torque

Choose your Enerpac Torque Wrench using the untightening rule of thumb: Loosening torque equals about 250% of tightening torque.

Page: 278

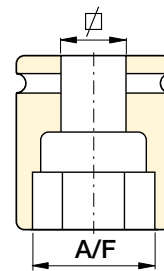

### Hexagon Bolt and Nut Sizes

See the table of hexagon sizes of bolts, nuts and related thread diameters.

Page: 277

## IMPERIAL SOCKETS

¾" Square Drive		1" Square Drive				1½" Square Drive				2½" Square Drive			
Model Number	A/F (inch)	Model Number	A/F (inch)	Model Number	A/F (inch)	Model Number	A/F (inch)	Model Number	A/F (inch)	Model Number	A/F (inch)	Model Number	A/F (inch)
BSH7519	¾"	BSH1019	¾"	BSH10231	2 5/16"	BSH15144	1 7/16"	BSH15281	2 13/16"	BSH25244	2 7/16"	BSH25419	4 3/16"
BSH75088	7/8"	BSH10088	7/8"	BSH10238	2 3/8"	BSH1538	1 1/2"	BSH15288	2 7/8"	BSH25250	2 1/2"	BSH25425	4 1/4"
BSH75094	15/16"	BSH10094	15/16"	BSH10244	2 7/16"	BSH15156	1 9/16"	BSH1575	2 15/16"	BSH2565	2 13/16"	BSH25110	4 5/16"
BSH7527	1 1/16"	BSH1027	1 1/16"	BSH10250	2 1/2"	BSH15163	1 5/8"	BSH15300	3"	BSH25263	2 5/8"	BSH25438	4 3/8"
BSH7530	1 3/16"	BSH1030	1 3/16"	BSH1065	2 9/16"	BSH1543	1 11/16"	BSH15306	3 1/16"	BSH25269	2 11/16"	BSH25450	4 1/2"
BSH75125	1 ¼"	BSH10125	1 ¼"	BSH10263	2 5/8"	BSH15175	1 ¾"	BSH15313	3 1/8"	BSH2570	2 ¾"	BSH25463	4 5/8"
BSH75131	1 5/16"	BSH10131	1 5/16"	BSH10269	2 11/16"	BSH1546	1 13/16"	BSH15319	3 3/16"	BSH25281	2 11/16"	BSH25475	4 ¾"
BSH7535	1 3/8"	BSH1035	1 3/8"	BSH1070	2 ¾"	BSH15188	1 7/8"	BSH15325	3 ¼"	BSH25288	2 7/8"	BSH25488	4 7/8"
BSH75144	1 7/16"	BSH10144	1 7/16"	BSH10281	2 13/16"	BSH15194	1 15/16"	BSH15338	3 3/8"	BSH2575	2 15/16"	BSH25500	5"
BSH7538	1 1/2"	BSH1038	1 1/2"	BSH10288	2 7/8"	BSH15200	2"	BSH15350	3 1/2"	BSH25300	3"	BSH25513	5 1/8"
BSH75156	1 9/16"	BSH10156	1 9/16"	BSH1075	2 15/16"	BSH15206	2 1/16"	BSH15363	3 5/8"	BSH25306	3 1/16"	BSH25519	5 3/16"
BSH75163	1 5/8"	BSH10163	1 5/8"	BSH10300	3"	BSH15213	2 1/8"	BSH1595	3 ¾"	BSH25313	3 1/8"	BSH25525	5 1/4"
BSH7543	1 11/16"	BSH1043	1 11/16"	BSH10306	3 1/16"	BSH15219	2 3/16"	BSH15388	3 7/8"	BSH25319	3 3/16"	BSH25538	5 3/8"
BSH75175	1 ¾"	BSH10175	1 ¾"	BSH10313	3 1/8"	BSH15225	2 ¼"	BSH15100	3 15/16"	BSH25325	3 ¼"	BSH25140	5 1/2"
BSH7546	1 13/16"	BSH1046	1 13/16"	BSH10319	3 3/16"	BSH15231	2 5/16"	BSH15400	4"	BSH25338	3 3/8"	BSH25575	5 ¾"
BSH75188	1 7/8"	BSH10188	1 7/8"	BSH10325	3 ¼"	BSH15238	2 3/8"	BSH15105	4 1/8"	BSH25350	3 1/2"	BSH25150	5 7/8"
BSH75194	1 15/16"	BSH10194	1 15/16"	BSH10338	3 3/8"	BSH15244	2 7/16"	BSH15419	4 3/16"	BSH25363	3 5/8"	BSH25600	6"
BSH75200	2"	BSH10200	2"	BSH10350	3 1/2"	BSH15250	2 1/2"	BSH15425	4 ¼"	BSH2595	3 ¾"	BSH25613	6 1/8"
-	-	BSH10206	2 1/16"	BSH10363	3 5/8"	BSH1565	2 9/16"	BSH15110	4 5/16"	BSH25388	3 7/8"	-	-
-	-	BSH10213	2 1/8"	BSH1095	3 ¾"	BSH15263	2 5/8"	BSH15438	4 3/8"	BSH25100	3 15/16"	-	-
-	-	BSH10219	2 3/16"	BSH10388	3 7/8"	BSH15269	2 11/16"	BSH15450	4 1/2"	BSH25400	4"	-	-
-	-	BSH10225	2 ¼"	-	-	BSH1570	2 ¾"	BSH15463	4 5/8"	BSH25105	4 1/8"	-	-

Enerpac professional series steel torque wrenches provide reliable controlled tightening solutions across the industry.

### ***S3000X Square Drive Torque Wrench on wind tower erection and maintenance***

*S3000X used to connect wind tower segments during assembly and maintenance. A robust but compact solution is required for tightening of bolts on wind tower sections. Large numbers of fasteners require precise application of torque to ensure joint integrity is achieved and maintained. The Enerpac S-Series wrench was selected as it offers simple and reliable operation while providing accurate and repeatable results.*



### ***W4000X Low Profile Torque Wrench on an API Pipe Flange***

*Throughout the Oil and Gas, Petrochemical and Processing Industries, pipeline joints, valves, pumps and machinery present challenges for controlled bolting. The restricted access on this flange was easily overcome with an Enerpac W-Series Torque Wrench. These wrenches offer reliability and control, ensuring even and consistent torque is applied to all bolts.*

### ***S3000X on an oil and gas flange***

*During maintenance quick turnaround times are essential; S-Series wrenches are chosen as they provide a large angle of nut rotation per stroke, offering speed and accuracy in a compact ergonomic tool.*



▼ Shown: W4000PX drive unit and W4206X hexagon cassette



## Safety and Performance

- Superior strength to size ratio provides easy access to difficult to reach applications without sacrificing endurance
- 30° rotation angle and rapid return stroke provide fast operation
- Tough manifold design with added safety feature for enhanced operator safety

## Simplicity

- Fast release drive unit enables rapid exchange of cassettes, no tools required
- Quick and easy disassembly for maintenance without special tools
- Include robust handle which mounts on both sides and the tops of cassettes to allow for extra maneuverability

## Versatility

- Enhanced tilt and swivel TSP300 manifold for horizontal and vertical maneuverability, with greater durability <sup>1)</sup>
- X-Edition drive units, cassettes and most accessories are compatible with standard edition tools <sup>1)</sup>
- Drive unit compatible with UltraSlim and WCR-Series cassettes

## Accuracy

- Constant torque output provides accuracy of  $\pm 3\%$  across full stroke.

## Setting New Standards in Safety, Simplicity and Performance



### Two Handle Styles

Robust angled positioning handle comes standard with every W-Series (X-Edition) cassette. Straight positioning handles designed for extreme limited

access applications are available as accessories.

Compatible with W-Series (X-Edition) Cassettes	Model Nr. Angled positioning handles (standard)	Model Nr. Straight positioning handles (optional)
W2000PX, W4000PX	SWH6A	SWH6S
W8000PX, W15000PX	SWH10A	SWH10S
W22000PX, W35000PX	SWH10EA <sup>2)</sup>	

<sup>2)</sup> SWH10EA is an eyebolt handle.



### TSP300 Tilt & swivel manifold

Standard TSP300 tilt and swivel manifold with robust interlocking design provides 360° X-axis rotation and 160° Y-axis rotation.

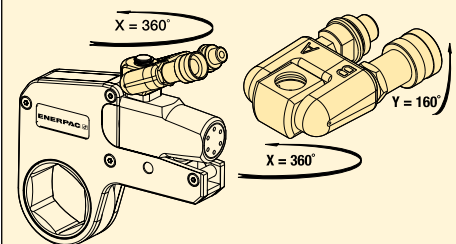

### ATEX declared. Calibration certificate included.

All X-edition tools are CE - ATEX declared and are shipped complete with a calibration certificate.



<sup>1)</sup> TSP300 is designed for X-Edition tools only, and is not compatible with previous edition tools. For replacement components for existing tools, refer to repair sheet on [www.enerpac.com](http://www.enerpac.com)

# Double-Acting Hydraulic Hexagon Torque Wrenches, X-Edition

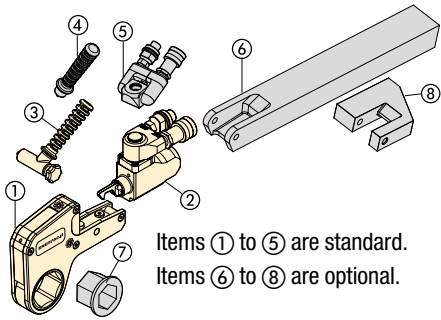

- ① Hexagon Cassette (pages 194-201)
- ② Drive Unit
- ③ Angled Positioning Handle (page 192)
- ④ Straight Positioning Handle
- ⑤ Pro Series Swivel
- ⑥ Extended Reaction Arm (page 205)
- ⑦ Reducer Insert (pages 194-201)
- ⑧ Reaction Paddle (page 205)

Items ① to ⑤ are standard.  
Items ⑥ to ⑧ are optional.

## W Series X-Edition



Nominal Torque at 690 bar:

**47.454 Nm**

Hexagon Range:

**30 - 155 mm / 1 1/16 - 6 1/8"**

Nose Radius:

**31 - 115 mm**

Maximum Operating Pressure:

**690 bar**

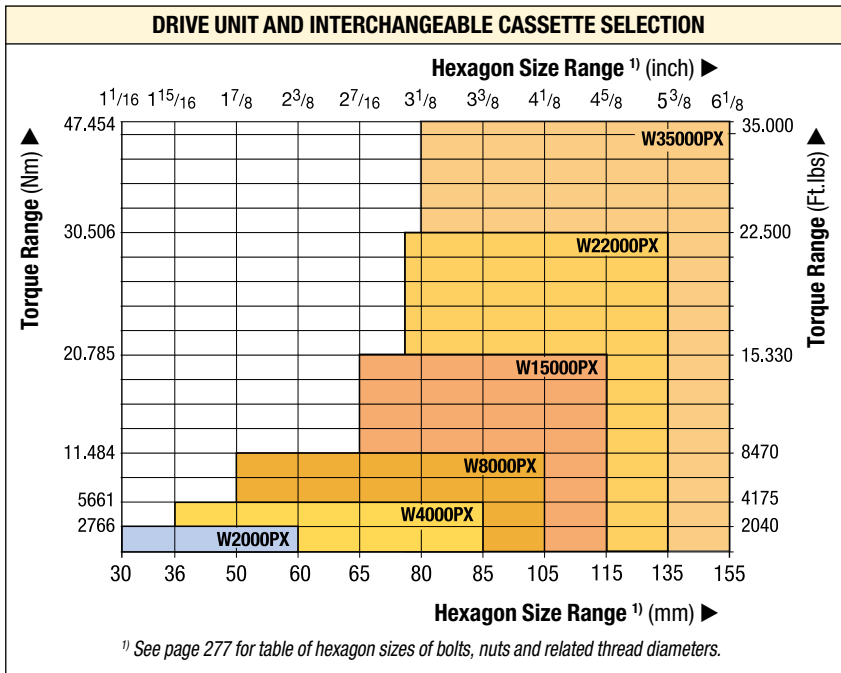

### Torque Wrench Pump Selection Matrix

For optimum speed and performance see the torque wrench and pump matrix.

Page: **212**

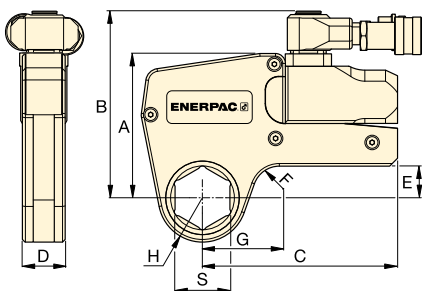

These rigid steel wrenches with low profile interchangeable hexagon cassettes guarantee durability and maximum versatility in bolting applications. ▶



### ▼ SELECTION CHART

Hexagon Range *		Nominal Torque at 690 bar		Drive Unit Model Number with TSP300 **	Minimum Torque		Dimensions (mm) (see pages 194-201 for dimensions G, H and S)						Weight (drive unit without hexagon cassette) (kg)
(mm)	(inch)	(Nm)	(Ft.lbs)		(Nm)	(Ft.lbs)	A	B	C	D	E	F	
30 - 60	1 1/16 - 2 3/8	2766	2040	<b>W2000PX</b>	276	204	109	141	148	32	24	20	1,4
36 - 85	1 5/16 - 3 3/8	5661	4175	<b>W4000PX</b>	566	417	136	167	178	41	33	20	2,0
50 - 105	1 7/8 - 4 1/8	11.484	8470	<b>W8000PX</b>	1148	847	172	205	208	53	42	25	3,0
65 - 115	2 7/16 - 4 5/8	20.785	15.330	<b>W15000PX</b>	2078	1533	207	240	253	63	50	20	5,0
75 - 135	2 15/16 - 5 3/8	30.506	22.500	<b>W22000PX</b>	3050	2250	227	266	297	77	48	35	7,7
80 - 155	3 1/8 - 6 1/8	47.454	35.000	<b>W35000PX</b>	4745	3500	268	301	345	91	69-73	50	11,4

\* Hexagon cassette with in-line reaction foot.

\*\* To order a W-series wrench without the TSP300 swivel, remove the "P" from the tool model number. Example: **W2000X**.

# W2000X, Inch-Cassettes & Reducer Inserts

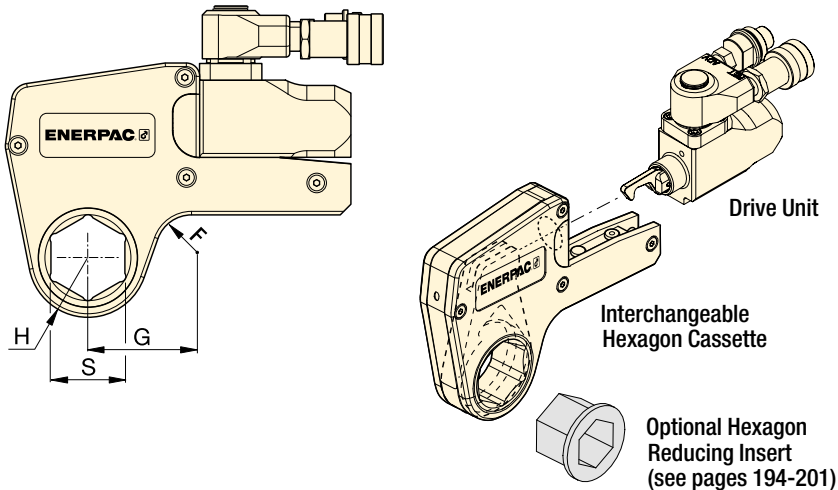

## W Series X-Edition



Nominal Torque at 690 bar:

**2766 Nm**

Hexagon Range:

**1<sup>1</sup>/<sub>16</sub> - 2<sup>3</sup>/<sub>8</sub> inch**

Maximum Operating Pressure:

**690 bar**



### Metric Sizes

For metric sizes of hexagon cassettes and reducer inserts see:

Page: **200**



### Hexagon Bolt and Nut Sizes

See the table for hexagon sizes of bolts, nuts and related thread diameters.

Page: **277**

## ▼ SELECTION CHART

Drive Unit Model Number	Hexagon Size <sup>1)</sup>	Nose Radius	Dim.	Model Number	Weight (kg)	Hexagon Reducer		Hexagon Reducer		Hexagon Reducer	
						Hexagon Reducer (inch)	Model Number	Hexagon Reducer (inch)	Model Number	Hexagon Reducer (inch)	Model Number
<b>W2000PX</b>	1 <sup>1</sup> / <sub>16</sub>	31,0	53,7	<b>W2101X</b>	2,1	-	-	-	-	-	-
	1 <sup>1</sup> / <sub>8</sub>	31,0	53,7	<b>W2102X</b>	2,1	-	-	-	-	-	-
	1 <sup>3</sup> / <sub>16</sub>	31,0	53,7	<b>W2103X</b>	2,1	-	-	-	-	-	-
	1 <sup>1</sup> / <sub>4</sub>	31,0	53,7	<b>W2104X</b>	2,1	-	-	-	-	-	-
	1 <sup>5</sup> / <sub>16</sub>	31,0	53,7	<b>W2105X</b>	2,1	-	-	-	-	-	-
	1 <sup>3</sup> / <sub>8</sub>	31,0	53,7	<b>W2106X</b>	2,1	-	-	-	-	-	-
	1 <sup>7</sup> / <sub>16</sub>	31,0	53,7	<b>W2107X</b>	2,1	1 <sup>7</sup> / <sub>16</sub> - 1 <sup>1</sup> / <sub>8</sub>	<b>W2107R102</b>	-	-	-	-
	1 <sup>1</sup> / <sub>2</sub>	33,5	58,2	<b>W2108X</b>	2,2	-	-	-	-	-	-
	1 <sup>9</sup> / <sub>16</sub>	33,5	58,2	<b>W2109X</b>	2,2	-	-	-	-	-	-
	1 <sup>5</sup> / <sub>8</sub>	33,5	58,2	<b>W2110X</b>	2,2	1 <sup>5</sup> / <sub>8</sub> - 1 <sup>1</sup> / <sub>4</sub>	<b>W2110R104</b>	1 <sup>5</sup> / <sub>8</sub> - 1 <sup>3</sup> / <sub>16</sub>	<b>W2110R103</b>	-	-
	1 <sup>11</sup> / <sub>16</sub>	36,5	60,5	<b>W2111X</b>	2,2	-	-	-	-	-	-
	1 <sup>3</sup> / <sub>4</sub>	36,5	60,5	<b>W2112X</b>	2,2	-	-	-	-	-	-
	1 <sup>13</sup> / <sub>16</sub>	36,5	60,5	<b>W2113X</b>	2,2	1 <sup>13</sup> / <sub>16</sub> - 1 <sup>7</sup> / <sub>16</sub>	<b>W2113R107</b>	1 <sup>13</sup> / <sub>16</sub> - 1 <sup>1</sup> / <sub>4</sub>	<b>W2113R104</b>	-	-
	1 <sup>7</sup> / <sub>8</sub>	39,0	63,1	<b>W2114X</b>	2,2	-	-	-	-	-	-
	1 <sup>5</sup> / <sub>8</sub>	39,0	63,1	<b>W2115X</b>	2,2	-	-	-	-	-	-
	2	39,0	63,1	<b>W2200X</b>	2,2	2 - 1 <sup>5</sup> / <sub>8</sub>	<b>W2200R110</b>	2 - 1 <sup>7</sup> / <sub>16</sub>	<b>W2200R107</b>	-	-
	2 <sup>1</sup> / <sub>16</sub>	41,8	68,6	<b>W2201X</b>	2,3	-	-	-	-	-	-
	2 <sup>1</sup> / <sub>8</sub>	41,8	68,6	<b>W2202X</b>	2,3	-	-	-	-	-	-
	2 <sup>3</sup> / <sub>16</sub>	41,8	68,6	<b>W2203X</b>	2,3	2 <sup>3</sup> / <sub>16</sub> - 1 <sup>13</sup> / <sub>16</sub>	<b>W2203R113</b>	2 <sup>3</sup> / <sub>16</sub> - 1 <sup>5</sup> / <sub>8</sub>	<b>W2203R110</b>	2 <sup>3</sup> / <sub>16</sub> - 1 <sup>7</sup> / <sub>16</sub>	<b>W2203R107</b>
	2 <sup>1</sup> / <sub>4</sub>	44,5	64,8	<b>W2204X</b>	2,2	-	-	-	-	-	-
2 <sup>5</sup> / <sub>16</sub>	44,5	64,8	<b>W2205X</b>	2,2	-	-	-	-	-	-	
2 <sup>3</sup> / <sub>8</sub>	44,5	64,8	<b>W2206X</b>	2,2	2 <sup>3</sup> / <sub>8</sub> - 2	<b>W2206R200</b>	2 <sup>3</sup> / <sub>8</sub> - 1 <sup>7</sup> / <sub>8</sub>	<b>W2206R114</b>	2 <sup>3</sup> / <sub>8</sub> - 1 <sup>13</sup> / <sub>16</sub>	<b>W2206R113</b>	
-	-	-	-	-	-	2 <sup>3</sup> / <sub>8</sub> - 1 <sup>1</sup> / <sub>2</sub>	<b>W2206R108</b>	2 <sup>3</sup> / <sub>8</sub> - 1 <sup>7</sup> / <sub>16</sub>	<b>W2206R107</b>	2 <sup>3</sup> / <sub>8</sub> - 1 <sup>5</sup> / <sub>16</sub>	<b>W2206R110</b>

<sup>1)</sup> See page 277 for table of hexagon sizes of bolts, nuts and related thread diameters.

# W4000X-Series, Inch-Cassettes & Reducer Inserts

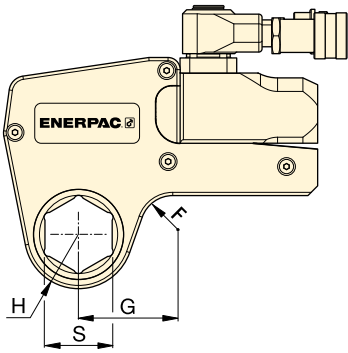

Nominal Torque at 690 bar:

**5661 Nm**

Hexagon Range:

**1<sup>5</sup>/<sub>16</sub> - 3<sup>3</sup>/<sub>8</sub> inch**

Maximum Operating Pressure:

**690 bar**

**W**  
Series  
X-Edition



Drive Unit Model Number	Hexagon Size <sup>1)</sup>	Nose Radius	Dim.	Model Number	Weight	Hexagon Reducer		Hexagon Reducer		Hexagon Reducer	
						Hexagon Reducer (inch)	Model Number	Hexagon Reducer (inch)	Model Number	Hexagon Reducer (inch)	Model Number
W4000PX	S (inch)	H (mm)	G (mm)		(kg)						
	1 <sup>5</sup> / <sub>16</sub>	37,0	61,0	W4105X	3,7	-	-	-	-	-	-
	1 <sup>3</sup> / <sub>8</sub>	37,0	61,0	W4106X	3,7	-	-	-	-	-	-
	1 <sup>7</sup> / <sub>16</sub>	37,0	61,0	W4107X	3,7	-	-	-	-	-	-
	1 <sup>1</sup> / <sub>2</sub>	37,0	61,0	W4108X	3,7	-	-	-	-	-	-
	1 <sup>9</sup> / <sub>16</sub>	37,0	61,0	W4109X	3,7	-	-	-	-	-	-
	1 <sup>5</sup> / <sub>8</sub>	37,0	61,0	W4110X	3,7	-	-	-	-	-	-
	1 <sup>11</sup> / <sub>16</sub>	39,5	64,0	W4111X	3,8	-	-	-	-	-	-
	1 <sup>3</sup> / <sub>4</sub>	39,5	64,0	W4112X	3,8	-	-	-	-	-	-
	1 <sup>13</sup> / <sub>16</sub>	39,5	64,0	W4113X	3,8	-	-	-	-	-	-
	1 <sup>7</sup> / <sub>8</sub>	41,5	66,7	W4114X	3,9	-	-	-	-	-	-
	1 <sup>15</sup> / <sub>16</sub>	41,5	66,7	W4115X	3,9	-	-	-	-	-	-
	2	41,5	66,7	W4200X	3,9	2 - 1 <sup>7</sup> / <sub>16</sub>	W4200R107	-	-	-	-
	2 <sup>1</sup> / <sub>16</sub>	44,0	73,4	W4201X	4,0	-	-	-	-	-	-
	2 <sup>1</sup> / <sub>8</sub>	44,0	73,4	W4202X	4,0	-	-	-	-	-	-
	2 <sup>3</sup> / <sub>16</sub>	44,0	73,4	W4203X	4,0	2 <sup>3</sup> / <sub>16</sub> - 1 <sup>5</sup> / <sub>8</sub>	W4203R110	2 <sup>3</sup> / <sub>16</sub> - 1 <sup>7</sup> / <sub>16</sub>	W4203R107	2 <sup>3</sup> / <sub>16</sub> - 1 <sup>1</sup> / <sub>4</sub>	W4203R104
	2 <sup>1</sup> / <sub>4</sub>	46,5	70,6	W4204X	4,1	-	-	-	-	-	-
	2 <sup>5</sup> / <sub>16</sub>	46,5	70,6	W4205X	4,1	-	-	-	-	-	-
	2 <sup>3</sup> / <sub>8</sub>	46,5	70,6	W4206X	4,1	2 <sup>3</sup> / <sub>8</sub> - 2	W4206R200	2 <sup>3</sup> / <sub>8</sub> - 1 <sup>13</sup> / <sub>16</sub>	W4206R113	2 <sup>3</sup> / <sub>8</sub> - 1 <sup>7</sup> / <sub>16</sub>	W4206R107
	-	-	-	-	-	2 <sup>3</sup> / <sub>8</sub> - 1 <sup>3</sup> / <sub>8</sub>	W4206R106	-	-	-	-
	2 <sup>7</sup> / <sub>16</sub>	49,5	76,2	W4207X	4,1	2 <sup>7</sup> / <sub>16</sub> - 2	W4207R200	-	-	-	-
	2 <sup>1</sup> / <sub>2</sub>	49,5	76,2	W4208X	4,1	2 <sup>1</sup> / <sub>2</sub> - 2	W4208R200	2 <sup>1</sup> / <sub>2</sub> - 1 <sup>7</sup> / <sub>16</sub>	W4208R113	2 <sup>1</sup> / <sub>2</sub> - 2 <sup>1</sup> / <sub>16</sub>	W4208R201
	2 <sup>9</sup> / <sub>16</sub>	49,5	76,2	W4209X	4,1	2 <sup>9</sup> / <sub>16</sub> - 2 <sup>3</sup> / <sub>16</sub>	W4209R203	2 <sup>9</sup> / <sub>16</sub> - 2 <sup>1</sup> / <sub>8</sub>	W4209R202	2 <sup>9</sup> / <sub>16</sub> - 2 <sup>1</sup> / <sub>16</sub>	W4209R201
	-	-	-	-	-	2 <sup>9</sup> / <sub>16</sub> - 2	W4209R200	2 <sup>9</sup> / <sub>16</sub> - 1 <sup>13</sup> / <sub>16</sub>	W4209R113	-	-
	2 <sup>5</sup> / <sub>8</sub>	52,5	78,3	W4210X	4,2	-	-	-	-	-	-
	2 <sup>11</sup> / <sub>16</sub>	52,5	78,3	W4211X	4,2	-	-	-	-	-	-
	2 <sup>3</sup> / <sub>4</sub>	52,5	78,3	W4212X	4,2	2 <sup>3</sup> / <sub>4</sub> - 2 <sup>3</sup> / <sub>8</sub>	W4212R206	2 <sup>3</sup> / <sub>4</sub> - 2 <sup>3</sup> / <sub>16</sub>	W4212R203	2 <sup>3</sup> / <sub>4</sub> - 2 <sup>1</sup> / <sub>8</sub>	W4212R202
	2 <sup>13</sup> / <sub>16</sub>	55,3	81,6	W4213X	4,3	-	-	-	-	-	-
	2 <sup>7</sup> / <sub>8</sub>	55,3	81,6	W4214X	4,3	-	-	-	-	-	-
	2 <sup>15</sup> / <sub>16</sub>	55,3	81,6	W4215X	4,3	2 <sup>15</sup> / <sub>16</sub> - 2 <sup>9</sup> / <sub>16</sub>	W4215R209	2 <sup>15</sup> / <sub>16</sub> - 2 <sup>3</sup> / <sub>8</sub>	W4215R206	2 <sup>15</sup> / <sub>16</sub> - 2 <sup>3</sup> / <sub>16</sub>	W4215R203
	-	-	-	-	-	2 <sup>15</sup> / <sub>16</sub> - 2	W4215R200	-	-	-	-
	3	58,5	83,5	W4300X	4,4	3 - 2 <sup>9</sup> / <sub>16</sub>	W4300R203	-	-	-	-
	3 <sup>1</sup> / <sub>16</sub>	58,5	83,5	W4301X	4,4	-	-	-	-	-	-
	3 <sup>1</sup> / <sub>8</sub>	58,5	83,5	W4302X	4,4	3 <sup>1</sup> / <sub>8</sub> - 2 <sup>3</sup> / <sub>4</sub>	W4302R212	3 <sup>1</sup> / <sub>8</sub> - 2 <sup>9</sup> / <sub>16</sub>	W4302R209	3 <sup>1</sup> / <sub>8</sub> - 2 <sup>3</sup> / <sub>8</sub>	W4302R206
	-	-	-	-	-	3 <sup>1</sup> / <sub>8</sub> - 2 <sup>5</sup> / <sub>16</sub>	W4302R205	3 <sup>1</sup> / <sub>8</sub> - 2 <sup>1</sup> / <sub>4</sub>	W4302R204	3 <sup>1</sup> / <sub>8</sub> - 2 <sup>3</sup> / <sub>16</sub>	W4302R203
	-	-	-	-	-	3 <sup>1</sup> / <sub>8</sub> - 2 <sup>3</sup> / <sub>16</sub>	W4302R203	3 <sup>1</sup> / <sub>8</sub> - 2 <sup>1</sup> / <sub>8</sub>	W4302R202	3 <sup>1</sup> / <sub>8</sub> - 2	W4302R200
3 <sup>3</sup> / <sub>16</sub>	62,0	85,5	W4303X	4,5	-	-	-	-	-	-	
3 <sup>1</sup> / <sub>4</sub>	62,0	85,5	W4304X	4,5	-	-	-	-	-	-	
3 <sup>5</sup> / <sub>16</sub>	62,0	85,5	W4305X	4,5	-	-	-	-	-	-	
3 <sup>3</sup> / <sub>8</sub>	62,0	85,5	W4306X	4,5	-	-	-	-	-	-	

<sup>1)</sup> See page 277 for table of hexagon sizes of bolts, nuts and related thread diameters.

# W8000X-Series, Inch-Cassettes & Reducers

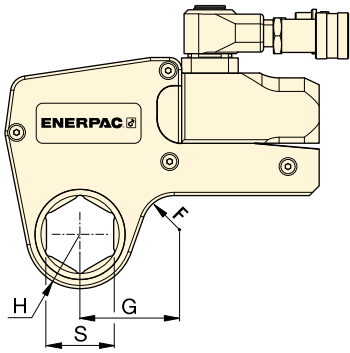

Nominal Torque at 690 bar:

**11.484 Nm**

Hexagon Range:

**1<sup>7</sup>/<sub>8</sub> - 4<sup>1</sup>/<sub>8</sub> inch**

Maximum Operating Pressure:

**690 bar**

**W**  
Series  
X-Edition



▼ SELECTION CHART

Drive Unit Model Number	Hexagon Size <sup>1)</sup>	Nose Radius	Dim.	Model Number	Weight (kg)	Hexagon Reducer		Hexagon Reducer		Hexagon Reducer	
						Hexagon Reducer (inch)	Model Number	Hexagon Reducer (inch)	Model Number	Hexagon Reducer (inch)	Model Number
W8000PX	S (inch)	H (mm)	G (mm)		(kg)	Hexagon Reducer (inch)	Model Number	Hexagon Reducer (inch)	Model Number	Hexagon Reducer (inch)	Model Number
	1 <sup>7</sup> / <sub>8</sub>	45,0	78,2	W8114X	8,1	–	–	–	–	–	–
	1 <sup>15</sup> / <sub>16</sub>	45,0	78,2	W8115X	8,1	–	–	–	–	–	–
	2	45,0	78,2	W8200X	8,1	–	–	–	–	–	–
	2 <sup>1</sup> / <sub>16</sub>	48,0	80,0	W8201X	8,1	–	–	–	–	–	–
	2 <sup>1</sup> / <sub>8</sub>	48,0	80,0	W8202X	8,1	–	–	–	–	–	–
	2 <sup>3</sup> / <sub>16</sub>	48,0	80,0	W8203X	8,1	–	–	–	–	–	–
	2 <sup>1</sup> / <sub>4</sub>	51,0	82,5	W8204X	8,1	–	–	–	–	–	–
	2 <sup>5</sup> / <sub>16</sub>	51,0	82,5	W8205X	8,1	–	–	–	–	–	–
	2 <sup>3</sup> / <sub>8</sub>	51,0	82,5	W8206X	8,1	–	–	–	–	–	–
	2 <sup>7</sup> / <sub>16</sub>	52,5	85,9	W8207X	8,1	–	–	–	–	–	–
	2 <sup>1</sup> / <sub>2</sub>	52,5	85,9	W8208X	8,1	–	–	–	–	–	–
	2 <sup>9</sup> / <sub>16</sub>	52,5	85,9	W8209X	8,1	2 <sup>9</sup> / <sub>16</sub> - 2	W8209R200	–	–	–	–
	2 <sup>5</sup> / <sub>8</sub>	56,0	84,8	W8210X	8,1	–	–	–	–	–	–
	2 <sup>11</sup> / <sub>16</sub>	56,0	84,8	W8211X	7,9	–	–	–	–	–	–
	2 <sup>3</sup> / <sub>4</sub>	56,0	84,8	W8212X	7,9	2 <sup>3</sup> / <sub>4</sub> - 2 <sup>3</sup> / <sub>16</sub>	W8212R203	–	–	–	–
	2 <sup>13</sup> / <sub>16</sub>	58,0	85,0	W8213X	7,9	–	–	–	–	–	–
	2 <sup>7</sup> / <sub>8</sub>	58,0	85,0	W8214X	7,9	–	–	–	–	–	–
	2 <sup>15</sup> / <sub>16</sub>	58,0	85,0	W8215X	7,9	2 <sup>15</sup> / <sub>16</sub> - 2 <sup>3</sup> / <sub>8</sub>	W8215R206	2 <sup>15</sup> / <sub>16</sub> - 2 <sup>3</sup> / <sub>16</sub>	W8215R203	–	–
	3	60,5	89,5	W8300X	8,0	–	–	–	–	–	–
	3 <sup>1</sup> / <sub>16</sub>	60,5	89,5	W8301X	8,0	–	–	–	–	–	–
	3 <sup>1</sup> / <sub>8</sub>	60,5	89,5	W8302X	8,0	3 <sup>1</sup> / <sub>8</sub> - 2 <sup>9</sup> / <sub>16</sub>	W8302R209	3 <sup>1</sup> / <sub>8</sub> - 2 <sup>3</sup> / <sub>8</sub>	W8302R206	3 <sup>1</sup> / <sub>8</sub> - 2 <sup>9</sup> / <sub>16</sub>	W8302R203
	–	–	–	–	–	3 <sup>1</sup> / <sub>8</sub> - 2	W8302R200	–	–	–	–
	3 <sup>3</sup> / <sub>16</sub>	66,0	92,2	W8303X	8,2	–	–	–	–	–	–
	3 <sup>1</sup> / <sub>4</sub>	66,0	92,2	W8304X	8,2	–	–	–	–	–	–
	3 <sup>5</sup> / <sub>16</sub>	66,0	92,2	W8305X	8,2	–	–	–	–	–	–
	3 <sup>3</sup> / <sub>8</sub>	66,0	92,2	W8306X	8,2	–	–	–	–	–	–
	3 <sup>7</sup> / <sub>16</sub>	66,0	92,2	W8307IX	8,2	–	–	–	–	–	–
	3 <sup>1</sup> / <sub>2</sub>	66,0	92,2	W8308X	8,2	3 <sup>1</sup> / <sub>2</sub> - 3	W8308R300	3 <sup>1</sup> / <sub>2</sub> - 2 <sup>15</sup> / <sub>16</sub>	W8308R215	3 <sup>1</sup> / <sub>2</sub> - 2 <sup>3</sup> / <sub>4</sub>	W8308R212
	3 <sup>9</sup> / <sub>16</sub>	74,0	102,9	W8309X	8,8	–	–	–	–	–	–
	3 <sup>5</sup> / <sub>8</sub>	74,0	102,9	W8310X	8,8	–	–	–	–	–	–
	3 <sup>11</sup> / <sub>16</sub>	74,0	102,9	W8311X	8,8	–	–	–	–	–	–
3 <sup>3</sup> / <sub>4</sub>	74,0	102,9	W8312X	8,8	3 <sup>3</sup> / <sub>4</sub> - 3 <sup>1</sup> / <sub>8</sub>	W8312R302	3 <sup>3</sup> / <sub>4</sub> - 2 <sup>15</sup> / <sub>16</sub>	W8312R215	3 <sup>3</sup> / <sub>4</sub> - 2 <sup>3</sup> / <sub>4</sub>	W8312R212	
3 <sup>13</sup> / <sub>16</sub>	74,0	102,9	W8313X	8,8	–	–	–	–	–	–	
3 <sup>7</sup> / <sub>8</sub>	74,0	102,9	W8314X	8,8	3 <sup>7</sup> / <sub>8</sub> - 3 <sup>1</sup> / <sub>8</sub>	W8314R302	3 <sup>7</sup> / <sub>8</sub> - 2 <sup>15</sup> / <sub>16</sub>	W8314R215	–	–	
3 <sup>15</sup> / <sub>16</sub>	79,5	110,0	W8315X	9,3	–	–	–	–	–	–	
4	79,5	110,0	W8400X	9,3	–	–	–	–	–	–	
4 <sup>1</sup> / <sub>16</sub>	79,5	110,0	W8401IX	9,3	–	–	–	–	–	–	
4 <sup>1</sup> / <sub>8</sub>	79,5	110,0	W8402X	9,3	–	–	–	–	–	–	

<sup>1)</sup> See page 277 for table of hexagon sizes of bolts, nuts and related thread diameters.

# W15000X-Series, Inch-Cassettes & Reducer Inserts

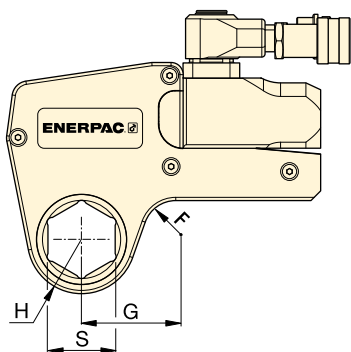

Nominal Torque at 690 bar:

**20.785 Nm**

Hexagon Range:

**2<sup>1</sup>/<sub>8</sub> - 4<sup>5</sup>/<sub>8</sub> inch**

Maximum Operating Pressure:

**690 bar**

**W**  
Series  
X-Edition



▼ SELECTION CHART

Drive Unit Model Number	Hexagon Size <sup>1)</sup>	Nose Radius	Dim.	Model Number	Weight	Hexagon Reducer		Hexagon Reducer		Hexagon Reducer	
						Hexagon Reducer (inch)	Model Number	Hexagon Reducer (inch)	Model Number	Hexagon Reducer (inch)	Model Number
W15000PX	S (inch)	H (mm)	G (mm)		(kg)						
	2 <sup>7</sup> / <sub>16</sub>	59,0	88,6	W15207X	13,6	-	-	-	-	-	-
	2 <sup>1</sup> / <sub>2</sub>	59,0	88,6	W15208X	13,6	-	-	-	-	-	-
	2 <sup>9</sup> / <sub>16</sub>	59,0	88,6	W15209X	13,6	-	-	-	-	-	-
	2 <sup>5</sup> / <sub>8</sub>	59,0	88,6	W15210X	13,6	-	-	-	-	-	-
	2 <sup>11</sup> / <sub>16</sub>	59,0	88,6	W15211X	13,6	-	-	-	-	-	-
	2 <sup>3</sup> / <sub>4</sub>	59,0	88,6	W15212X	13,6	-	-	-	-	-	-
	2 <sup>13</sup> / <sub>16</sub>	62,0	90,5	W15213X	13,7	-	-	-	-	-	-
	2 <sup>7</sup> / <sub>8</sub>	62,0	90,5	W15214X	13,7	-	-	-	-	-	-
	2 <sup>15</sup> / <sub>16</sub>	62,0	90,5	W15215X	13,7	-	-	-	-	-	-
	3	64,5	92,9	W15300X	13,8	3 - 2 <sup>1</sup> / <sub>8</sub>	W15300R202	-	-	-	-
	3 <sup>1</sup> / <sub>16</sub>	64,5	92,9	W15301X	13,8	-	-	-	-	-	-
	3 <sup>1</sup> / <sub>8</sub>	64,5	92,9	W15302X	13,8	3 <sup>1</sup> / <sub>8</sub> - 2 <sup>9</sup> / <sub>16</sub>	W15302R209	-	-	-	-
	3 <sup>3</sup> / <sub>16</sub>	69,5	96,6	W15303X	14,1	-	-	-	-	-	-
	3 <sup>1</sup> / <sub>4</sub>	69,5	96,6	W15304X	14,1	-	-	-	-	-	-
	3 <sup>5</sup> / <sub>16</sub>	69,5	96,6	W15305X	14,1	-	-	-	-	-	-
	3 <sup>3</sup> / <sub>8</sub>	69,5	96,6	W15306X	14,1	-	-	-	-	-	-
	3 <sup>7</sup> / <sub>16</sub>	69,5	96,6	W15307IX	14,1	-	-	-	-	-	-
	3 <sup>1</sup> / <sub>2</sub>	69,5	96,6	W15308X	14,1	3 <sup>1</sup> / <sub>2</sub> - 2 <sup>15</sup> / <sub>16</sub>	W15308R215	3 <sup>1</sup> / <sub>2</sub> - 2 <sup>3</sup> / <sub>4</sub>	W15308R212	-	-
	3 <sup>9</sup> / <sub>16</sub>	75,0	101,8	W15309X	14,6	-	-	-	-	-	-
	3 <sup>5</sup> / <sub>8</sub>	75,0	101,8	W15310X	14,6	-	-	-	-	-	-
	3 <sup>11</sup> / <sub>16</sub>	75,0	101,8	W15311X	14,6	-	-	-	-	-	-
	3 <sup>3</sup> / <sub>4</sub>	75,0	101,8	W15312X	14,6	3 <sup>3</sup> / <sub>4</sub> - 3 <sup>1</sup> / <sub>8</sub>	W15312R302	3 <sup>3</sup> / <sub>4</sub> - 2 <sup>15</sup> / <sub>16</sub>	W15312R215	-	-
	3 <sup>13</sup> / <sub>16</sub>	75,0	101,8	W15313X	14,5	-	-	-	-	-	-
	3 <sup>7</sup> / <sub>8</sub>	75,0	101,8	W15314X	14,5	3 <sup>7</sup> / <sub>8</sub> - 3 <sup>1</sup> / <sub>8</sub>	W15314R302	3 <sup>7</sup> / <sub>8</sub> - 2 <sup>15</sup> / <sub>16</sub>	W15314R215	-	-
	3 <sup>15</sup> / <sub>16</sub>	80,5	103,1	W15315X	14,8	-	-	-	-	-	-
	4	80,5	103,1	W15400X	14,8	-	-	-	-	-	-
	4 <sup>1</sup> / <sub>16</sub>	80,5	103,1	W15401IX	14,8	-	-	-	-	-	-
	4 <sup>1</sup> / <sub>8</sub>	80,5	103,1	W15402X	14,8	4 <sup>1</sup> / <sub>8</sub> - 3 <sup>1</sup> / <sub>2</sub>	W15402R308	4 <sup>1</sup> / <sub>8</sub> - 3 <sup>5</sup> / <sub>16</sub>	W15402R305	4 <sup>1</sup> / <sub>8</sub> - 3 <sup>1</sup> / <sub>4</sub>	W15402R304
	4 <sup>3</sup> / <sub>16</sub>	80,5	103,1	W15403IX	14,8	-	-	-	-	-	-
	4 <sup>1</sup> / <sub>4</sub>	80,5	103,1	W15404X	14,8	4 <sup>1</sup> / <sub>4</sub> - 3 <sup>1</sup> / <sub>2</sub>	W15404R308	4 <sup>1</sup> / <sub>4</sub> - 3 <sup>1</sup> / <sub>8</sub>	W15404R302	-	-
	4 <sup>5</sup> / <sub>16</sub>	87,5	114,8	W15405X	15,1	-	-	-	-	-	-
4 <sup>3</sup> / <sub>8</sub>	87,5	114,8	W15406X	15,1	-	-	-	-	-	-	
4 <sup>7</sup> / <sub>16</sub>	87,5	114,8	W15407X	15,1	-	-	-	-	-	-	
4 <sup>1</sup> / <sub>2</sub>	87,5	114,8	W15408IX	15,1	-	-	-	-	-	-	
4 <sup>9</sup> / <sub>16</sub>	87,5	114,8	W15409IX	15,1	-	-	-	-	-	-	
4 <sup>5</sup> / <sub>8</sub>	87,5	114,8	W15410IX	15,1	4 <sup>5</sup> / <sub>8</sub> - 3 <sup>15</sup> / <sub>16</sub>	W15410R315	4 <sup>5</sup> / <sub>8</sub> - 3 <sup>7</sup> / <sub>8</sub>	W15410R314	4 <sup>5</sup> / <sub>8</sub> - 3 <sup>3</sup> / <sub>4</sub>	W15410R312	
-	-	-	-	-	-	4 <sup>5</sup> / <sub>8</sub> - 3 <sup>1</sup> / <sub>2</sub>	W15410R308	-	-	-	
-	-	-	-	-	-	-	-	-	-	-	

<sup>1)</sup> See page 277 for table of hexagon sizes of bolts, nuts and related thread diameters.



# W22000X, Inch-Cassettes & Reducers

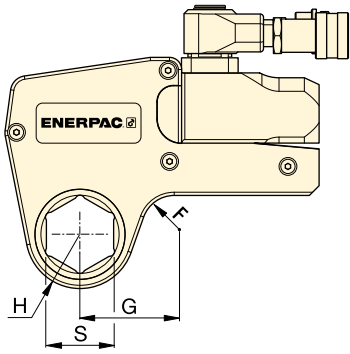

Nominal Torque at 690 bar:

**30.506 Nm**

Hexagon Range:

**2<sup>15</sup>/<sub>16</sub> - 5<sup>3</sup>/<sub>8</sub> inch**





Maximum Operating Pressure:

**690 bar**

**W**  
Series  
X-Edition



▼ SELECTION CHART

Drive Unit Model Number	Hexagon Size <sup>1)</sup> S (inch)	Nose Radius H (mm)	G (mm)	Model Nr. Cassette 	Weight (kg)						
						Hexagon Reducer (inch)	Model Number Reducer	Hexagon Reducer (inch)	Model Number Reducer	Hexagon Reducer (inch)	Model Number Reducer
W22000PX	2 <sup>15</sup> / <sub>16</sub>	67,0	102,1	W22215X	22,1	-	-	-	-	-	-
	3	67,0	102,1	W22300X	22,0	-	-	-	-	-	-
	3 <sup>1</sup> / <sub>16</sub>	67,0	102,1	W22301X	21,9	-	-	-	-	-	-
	3 <sup>1</sup> / <sub>8</sub>	67,0	102,1	W22302X	21,6	3 <sup>1</sup> / <sub>8</sub> - 2 <sup>3</sup> / <sub>8</sub>	W22302R206	3 <sup>1</sup> / <sub>8</sub> - 2 <sup>3</sup> / <sub>16</sub>	W22302R203	-	-
	3 <sup>3</sup> / <sub>16</sub>	72,4	107,4	W22303X	22,9	-	-	-	-	-	-
	3 <sup>1</sup> / <sub>4</sub>	72,4	107,4	W22304X	22,8	-	-	-	-	-	-
	3 <sup>5</sup> / <sub>16</sub>	72,4	107,4	W22305X	22,6	-	-	-	-	-	-
	3 <sup>3</sup> / <sub>8</sub>	72,4	107,4	W22306X	22,5	-	-	-	-	-	-
	3 <sup>7</sup> / <sub>16</sub>	72,4	107,4	W22307IX	22,8	-	-	-	-	-	-
	3 <sup>1</sup> / <sub>2</sub>	72,4	107,4	W22308X	22,2	3 <sup>1</sup> / <sub>2</sub> - 2 <sup>3</sup> / <sub>4</sub>	W22308R212	3 <sup>1</sup> / <sub>2</sub> - 2 <sup>9</sup> / <sub>16</sub>	W22308R209	3 <sup>1</sup> / <sub>2</sub> - 2 <sup>3</sup> / <sub>8</sub>	W22308R206
	3 <sup>9</sup> / <sub>16</sub>	77,9	113,0	W22309X	23,4	-	-	-	-	-	-
	3 <sup>5</sup> / <sub>8</sub>	77,9	113,0	W22310X	23,3	-	-	-	-	-	-
	3 <sup>11</sup> / <sub>16</sub>	77,9	113,0	W22311X	23,1	-	-	-	-	-	-
	3 <sup>3</sup> / <sub>4</sub>	77,9	113,0	W22312X	22,9	3 <sup>3</sup> / <sub>4</sub> - 2 <sup>15</sup> / <sub>16</sub>	W22312R215	-	-	-	-
	3 <sup>13</sup> / <sub>16</sub>	77,9	113,0	W22313X	22,8	-	-	-	-	-	-
	3 <sup>7</sup> / <sub>8</sub>	77,9	113,0	W22314X	22,6	3 <sup>7</sup> / <sub>8</sub> - 3 <sup>1</sup> / <sub>8</sub>	W22314R302	3 <sup>7</sup> / <sub>8</sub> - 2 <sup>15</sup> / <sub>16</sub>	W22314R215	3 <sup>7</sup> / <sub>8</sub> - 2 <sup>3</sup> / <sub>4</sub>	W22314R212
	3 <sup>15</sup> / <sub>16</sub>	85,1	119,9	W22315X	24,3	-	-	-	-	-	-
	4	85,1	119,9	W22400X	24,1	-	-	-	-	-	-
	4 <sup>1</sup> / <sub>16</sub>	85,1	119,9	W22401IX	24,0	-	-	-	-	-	-
	4 <sup>1</sup> / <sub>8</sub>	85,1	119,9	W22402X	23,6	-	-	-	-	-	-
	4 <sup>3</sup> / <sub>16</sub>	85,1	119,9	W22403IX	23,6	-	-	-	-	-	-
	4 <sup>1</sup> / <sub>4</sub>	85,1	119,9	W22404X	24,6	4 <sup>1</sup> / <sub>4</sub> - 3 <sup>1</sup> / <sub>2</sub>	W22404R308	4 <sup>1</sup> / <sub>4</sub> - 3 <sup>1</sup> / <sub>8</sub>	W22404R302	4 <sup>1</sup> / <sub>4</sub> - 2 <sup>15</sup> / <sub>16</sub>	W22404R215
	4 <sup>5</sup> / <sub>16</sub>	89,9	125,0	W22405X	24,6	-	-	-	-	-	-
	4 <sup>3</sup> / <sub>8</sub>	89,9	125,0	W22406X	24,5	-	-	-	-	-	-
	4 <sup>7</sup> / <sub>16</sub>	89,9	125,0	W22407X	24,3	-	-	-	-	-	-
	4 <sup>1</sup> / <sub>2</sub>	89,9	125,0	W22408IX	24,1	-	-	-	-	-	-
	4 <sup>9</sup> / <sub>16</sub>	89,9	125,0	W22409IX	23,9	-	-	-	-	-	-
	4 <sup>5</sup> / <sub>8</sub>	89,9	125,0	W22410IX	23,6	4 <sup>5</sup> / <sub>8</sub> - 3 <sup>7</sup> / <sub>8</sub>	W22410R314	4 <sup>5</sup> / <sub>8</sub> - 3 <sup>3</sup> / <sub>4</sub>	W22410R312	4 <sup>5</sup> / <sub>8</sub> - 3 <sup>1</sup> / <sub>2</sub>	W22410R308
	4 <sup>3</sup> / <sub>4</sub>	95,0	130,0	W22412X	24,7	-	-	-	-	-	-
	4 <sup>7</sup> / <sub>8</sub>	95,0	130,0	W22414X	24,3	-	-	-	-	-	-
	5	95,0	130,0	W22500X	23,8	5 - 4 <sup>1</sup> / <sub>4</sub>	W22500R404	5 - 4 <sup>1</sup> / <sub>8</sub>	W22500R402	5 - 3 <sup>7</sup> / <sub>8</sub>	W22500R314
	5 <sup>1</sup> / <sub>8</sub>	100,0	134,8	W22502X	25,0	-	-	-	-	-	-
5 <sup>3</sup> / <sub>16</sub>	100,0	134,8	W22503X	24,8	-	-	-	-	-	-	
5 <sup>1</sup> / <sub>4</sub>	100,0	134,8	W22504X	24,5	-	-	-	-	-	-	
5 <sup>3</sup> / <sub>8</sub>	100,0	134,8	W22506X	23,9	5 <sup>3</sup> / <sub>8</sub> - 4 <sup>5</sup> / <sub>8</sub>	W22506R410	5 <sup>3</sup> / <sub>8</sub> - 4 <sup>1</sup> / <sub>4</sub>	W22506R404	5 <sup>3</sup> / <sub>8</sub> - 4 <sup>1</sup> / <sub>8</sub>	W22506R402	
-	-	-	W22506X	23,9	5 <sup>3</sup> / <sub>8</sub> - 3 <sup>7</sup> / <sub>8</sub>	W22506R314	-	-	-	-	

<sup>1)</sup> See page 277 for table of hexagon sizes of bolts, nuts and related thread diameters.

# W35000X, Inch-Cassettes & Reducer Inserts

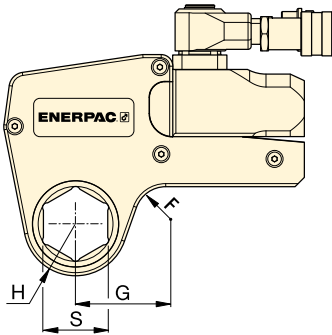

## ▼ SELECTION CHART

Drive Unit Model Number	Hexagon Size S	Nose Radius H	G	Model Nr. Cassette	Weight (kg)	Reducer	
						Hexagon Reducer (inch)	Model Number Reducer
W35000PX	3 1/8	76,0	126,8	W35302X	32,8	3 1/8 - 2	W35302R200
	3 3/16	76,0	126,8	W35303X	32,7	-	-
	3 1/4	76,0	126,8	W35304X	32,5	-	-
	3 5/16	76,0	126,8	W35305X	32,4	-	-
	3 3/8	76,0	126,8	W35306X	32,2	-	-
	3 7/16	76,0	126,8	W35307X	32,0	-	-
	3 1/2	76,0	126,8	W35308X	31,8	3 1/2 - 2 5/16	W35308R205
	3 9/16	81,5	132,5	W35309X	32,4	-	-
	3 5/8	81,5	132,5	W35310X	33,3	-	-
	3 11/16	81,5	132,5	W35311X	33,1	-	-
	3 3/4	81,5	132,5	W35312X	32,9	-	-
	3 13/16	81,5	132,5	W35313X	32,7	-	-
	3 7/8	81,5	132,5	W35314X	32,4	3 7/8 - 2 11/16	W35314R211
	3 15/16	87,0	137,0	W35315X	34,1	3 15/16 - 2 13/16	W35315R213
	4	87,0	137,0	W35400X	33,9	-	-
	4 1/16	87,0	137,0	W35401IX	33,7	-	-
	4 1/8	87,0	137,0	W35402X	33,5	-	-
	4 3/16	87,0	137,0	W35403IX	33,3	-	-
	4 1/4	87,0	137,0	W35404X	33,0	4 1/4 - 3 1/16	W35404R301
	4 5/16	93,0	143,0	W35405X	34,9	-	-
	4 3/8	93,0	143,0	W35406X	34,7	-	-
	4 7/16	93,0	143,0	W35407X	34,5	-	-
	4 1/2	93,0	143,0	W35408X	34,3	-	-
	4 9/16	93,0	143,0	W35409X	34,1	-	-
	4 5/8	93,0	143,0	W35410IX	33,7	4 5/8 - 3 5/8	W35410R310
	4 3/4	98,5	148,5	W35412X	35,6	4 3/4 - 3 3/4	W35412R312
	4 7/8	98,5	148,5	W35414X	34,9	-	-
	5	98,5	148,5	W35500X	34,3	5 - 4	W35500R400
	5 1/8	103,0	153,0	W35502X	35,8	5 1/8 - 4 1/8	W35502R402
	5 3/16	103,0	153,0	W35503IX	35,6	-	-
	5 1/4	103,0	153,0	W35504X	35,2	-	-
	5 3/8	103,0	153,0	W35506X	34,6	5 3/8 - 4 5/16	W35506R405
5 1/2	108,5	158,5	W35508X	36,2	-	-	
5 9/16	108,5	158,5	W35509X	36,0	-	-	
5 5/8	108,5	158,5	W35510X	35,6	-	-	
5 3/4	108,5	164,0	W35512X	34,9	5 3/4 - 4 3/4	W35512R412	
5 7/8	114,0	164,0	W35514X	36,7	5 7/8 - 4 7/8	W35514R414	
6	114,0	164,0	W35600X	36,1	-	-	
6 1/8	114,0	164,0	W35602X	35,3	6 1/8 - 5 1/8	W35602R502	

## W Series X-Edition



Nominal Torque at 690 bar:

**47.454 Nm**

Hexagon Range:

**3 1/8 - 6 1/8 inch**

Maximum Operating Pressure:

**690 bar**



### Hexagon Bolt and Nut Sizes

See the table for hexagon sizes of bolts, nuts and related thread diameters.

Page: 277

# W-Series, Metric Cassettes and Reducers

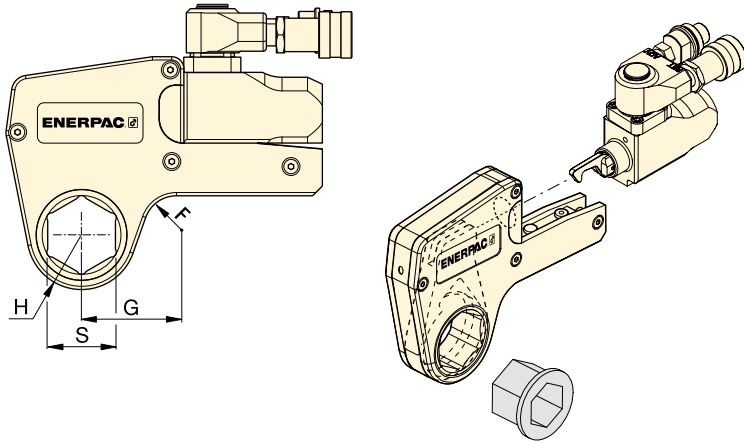

## W Series X-Edition







Hexagon Range:

**24 - 105 mm**

Maximum Operating Pressure:

**690 bar**

### ▼ SELECTION CHART

Drive Unit Model Number	Hexagon Size <sup>1)</sup>	Nose Radius	Dim.	Model Nr. Cassette							
						Hexagon Reducer (mm)	Model Number Reducer	Hexagon Reducer (mm)	Model Number Reducer	Hexagon Reducer (mm)	Model Number Reducer
<b>W2000PX</b> (2766 Nm)	30	31	54	W2103X	2,1	-	-	-	-	-	-
	32	31	54	W2104X	2,1	-	-	-	-	-	-
	36	31	54	W2107X	2,1	-	-	-	-	-	-
	38	34	58	W2108X	2,2	-	-	-	-	-	-
	41	34	58	W2110X	2,2	41 - 32	W2110R104	41 - 30	W2110R103	41 - 24	W2110R024M
	46	34	61	W2113X	2,2	46 - 36	W2113R107	46 - 32	W2113R104	-	-
	50	39	63	W2200X	2,2	50 - 41	W2200R110	50 - 36	W2200R107	-	-
	55	42	69	W2203X	2,3	55 - 46	W2203R113	55 - 41	W2203R110	55 - 36	W2203R107
	60	45	65	W2206X	2,2	60 - 50	W2206R200	60 - 46	W2206R113	60 - 41	W2206R110
	-	-	-	-	-	-	60 - 36	W2206R107	-	-	-
<b>W4000PX</b> (5661 Nm)	36	37	61	W4107X	3,7	-	-	-	-	-	-
	41	37	61	W4110X	3,7	-	-	-	-	-	-
	46	40	64	W4113X	3,8	-	-	-	-	-	-
	50	42	67	W4200X	3,9	50 - 36	W4200R107	-	-	-	-
	55	44	73	W4203X	4,0	55 - 41	W4203R110	55 - 36	W4203R107	55 - 32	W4203R104
	60	47	71	W4206X	4,1	60 - 50	W4206R200	60 - 46	W4206R113	60 - 36	W4206R107
	65	50	76	W4209X	4,1	65 - 55	W4209R203	65 - 50	W4209R200	65 - 46	W4209R113
	70	53	78	W4212X	4,2	70 - 60	W4212R206	70 - 55	W4212R203	-	-
	75	55	82	W4215X	4,3	75 - 65	W4215R209	75 - 60	W4215R206	-	-
	-	-	-	W4215X	-	75 - 55	W4215R203	75 - 50	W4215R200	-	-
	80	59	84	W4302X	-	-	-	80 - 70	W4302R212	80 - 65	W4302R209
	-	-	-	W4302X	-	80 - 55	W4302R203	80 - 50	W4302R200	-	-
<b>W8000PX</b> (11.484 Nm)	85	62	86	W4085MX	4,5	-	-	-	-	-	-
	50	45	78	W8200X	8,1	-	-	-	-	-	-
	55	48	80	W8203X	8,1	-	-	-	-	-	-
	60	51	83	W8206X	8,1	-	-	-	-	-	-
	65	56	85	W8209X	8,1	65 - 50	W8209R200	-	-	-	-
	70	56	85	W8212X	7,9	70 - 55	W8212R203	-	-	-	-
	75	58	85	W8215X	7,9	75 - 60	W8215R206	75 - 55	W8215R203	-	-
	80	61	90	W8302X	8	80 - 65	W8302R209	80 - 60	W8302R206	80 - 55	W8302R203
	-	-	-	-	-	80 - 50	W8302R200	-	-	-	-
	85	66	92	W8085MX	8,2	85 - 70	W8085R070M	85 - 65	W8085R065M	85 - 60	W8085R060M
	-	-	-	-	-	85 - 55	W8085R055M	-	-	-	-
	90	74	103	W8090MX	8,8	90 - 75	W8090R075M	-	-	-	-
	95	74	103	W8312X	8,8	95 - 80	W8312R302	95 - 75	W8312R215	-	-
	100	80	110	W8315X	9,3	-	-	-	-	-	-
105	80	110	W8402X	9,3	-	-	-	-	-	-	

<sup>1)</sup> See page 277 for table of hexagon sizes of bolts, nuts and related thread diameters.

# W-Series, Metric Cassettes and Reducers

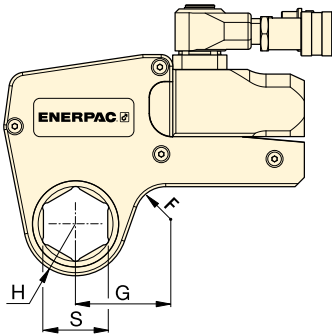

Hexagon Range:  
**50 - 155 mm**

Maximum Operating Pressure:  
**690 bar**

**W**  
Series  
X-Edition



## ▼ SELECTION CHART

Drive Unit Model Number	Hexagon Size <sup>1)</sup>	Nose Radius	Dim.	Model Nr. Cassette	Weight (kg)	Hexagon Reducer		Model Number Reducer	
						Hexagon Reducer (mm)	Model Number Reducer	Hexagon Reducer (mm)	Model Number Reducer
<b>W15000PX</b> (20.785 Nm)	65	59	89	W15209X	13,6	-	-	-	-
	70	59	89	W15212X	13,6	-	-	-	-
	75	62	91	W15215X	13,7	-	-	-	-
	80	65	93	W15302X	13,8	80 - 65	W15302R209	-	-
	85	70	97	W15085MX	14,1	85 - 70	W15085R070M	-	-
	90	75	102	W15090MX	14,5	90 - 75	W15090R75M	-	-
	95	75	102	W15312X	14,6	95 - 80	W15312R302	95 - 75	W15312R215
	100	81	103	W15315X	14,8	-	-	-	-
	105	81	103	W15402X	14,8	105 - 90	W15402R090M	-	-
	110	88	115	W15405X	15,1	110 - 95	W15110R095M	-	-
	115	88	115	W15115MX	15,1	115 - 100	W15115R100M	-	-
<b>W22000PX</b> (30.506 Nm)	75	67	102	W22215X	22,0	-	-	-	-
	80	67	102	W22302X	21,6	80-60	W22302R206	80 - 55	W22302R203
	85	73	107	W22085MX	22,5	85-65	W22085MR209	85 - 60	W22085MR206
	90	78	113	W22090MX	23,4	90-70	W22090M212	90 - 60	W22090MR206
	95	78	113	W22312X	22,9	95-75	W22312R215	-	-
	100	85	120	W22315X	24,3	-	-	-	-
	105	85	120	W22402X	23,4	-	-	-	-
	110	90	125	W22405X	24,6	-	-	-	-
	115	90	125	W22115MX	24,0	-	-	-	-
	120	95	130	W22412X	24,7	-	-	-	-
	123	95	130	W22123MX	24,4	-	-	-	-
<b>W35000PX</b> (47.454 Nm)	130	100	135	W22502X	25,0	-	-	-	-
	135	100	135	W22506X	23,9	135 - 105	W22506R402	-	-
	80	77	129	W35302X	32,8	80 - 50	W35302R200	-	-
	85	77	129	W35085MX	32,3	-	-	-	-
	90	82	135	W35090MX	33,5	90 - 60	W35090R206	-	-
	95	82	135	W35312X	32,9	-	-	-	-
	100	88	139	W35315X	34,1	-	-	-	-
	105	88	139	W35402X	33,5	-	-	-	-
	110	94	146	W35405X	34,9	110 - 85	W35405R085M	-	-
	115	94	146	W35115MX	34,2	-	-	-	-
	120	100	153	W35412X	35,6	120 - 95	W35412R312	-	-
	123	100	153	W35123MX	35,0	-	-	-	-
	130	104	160	W35502X	35,8	130 - 105	W35502R402	-	-
	135	104	160	W35506X	34,6	135 - 110	W35506R405	-	-
	140	110	163	W35508X	36,2	140 - 115	W35508R115M	-	-
	145	110	163	W35512X	34,9	145 - 120	W35512R412	-	-
150	115	169	W35514X	36,7	-	-	-	-	
151	115	169	W35151MX	36,5	-	-	-	-	
155	115	169	W35602X	35,3	155 - 130	W35602R502	-	-	

<sup>1)</sup> See page 277 for table of hexagon sizes of bolts, nuts and related thread diameters.

▼ W4206SL bi-hexagonal cassette with W4000X drive unit



## Versatility

- Lean, stepped width design allows tool to be mounted over bolts where other tools won't fit
- Bi-Hexagonal cassette allows twice as many positioning points on nut or bolt
- Robust top mounted handle stays out of the way, providing safe fastening in hard to reach areas
- Uses same drive unit as standard W-series hexagon cassettes

## Performance

- Premium components provide best-in-class endurance compared to other limited access tools

## Ease of Use

- Few moving parts are easily accessible for quick field maintenance
- Fast release drive unit enables rapid exchange of cassettes, no tools required
- Top mounted straight handle for improved tool handling and safety
- Enhanced tilt and swivel TSP300 manifold for horizontal and vertical maneuverability, with greater durability

## Accuracy

- Constant torque output provides  $\pm 3\%$  accuracy of across full stroke
- Calibration certificate shipped with every cassette.

**Your easy and long lasting solution to difficult access bolting applications**



### UltraSlim: Designed for Tight Spots

Stepped width design provides easy access in confined areas. UltraSlim cassettes fit where standard solutions won't.



### Built to Outperform

High endurance components keep working when others fail.



### Top Mounted Straight Handle

The top mounted straight handle is standard and provides safe and easy positioning and access to hard to reach fasteners.

Straight handle (standard)	<b>SWH6S</b>
Angled handle (optional)	<b>SWH6A</b>



### ATEX declared. Calibration certificate included.

All UltraSlim Series cassettes are CE - ATEX declared and are shipped complete with a calibration certificate.

CE  II 2 GD T4

*Slim enough to fit and tough enough to last. This UltraSlim wrench is the perfect controlled bolting solution for this oil and gas flange. ►*



# UltraSlim Bi-Hexagonal Cassettes



## UltraSlim Bi-Hexagonal Cassettes

Accessing narrow spaces normally requires significantly reducing the width of the torque wrench. For the tool operator, this has always meant vastly reduced tool durability, and/or reduced torque output.

By using the highest grade materials, perfecting the geometry, and placing the positioning handle on top of the tool for safe fastening, Enerpac UltraSlim cassettes are able to provide greater torque, get into tighter spaces, and vastly outperform the competition in product durability\*.

## Durability of Key Components\*

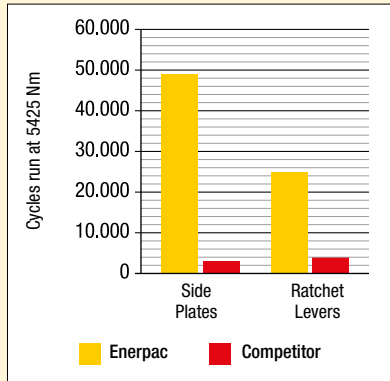

\* Average test results, whereby three Enerpac 46 mm UltraSlim cassettes and three competitor 46 mm cassettes were tested at 5425 Nm for 50,000 cycles. The Enerpac side plates never broke for the full duration of the test.

## W-SL Series UltraSlim



Nominal Torque Output:  
**5911 Nm**

Bi-Hexagonal Range:  
**46 - 75 mm**

Maximum Operating Pressure:  
**690 bar**



## Torque Wrench Pumps

System matched air and electric torque wrench pumps that are ideal for use with hydraulic torque wrenches.

Page: **212**



## Torque Wrench Hoses

Use Enerpac THQ-700 Series torque wrench hoses with W-Series torque wrenches to ensure the integrity of your hydraulic system.

6 m long, 2 hoses	<b>THQ-706T</b>
12 m long, 2 hoses	<b>THQ-712T</b>

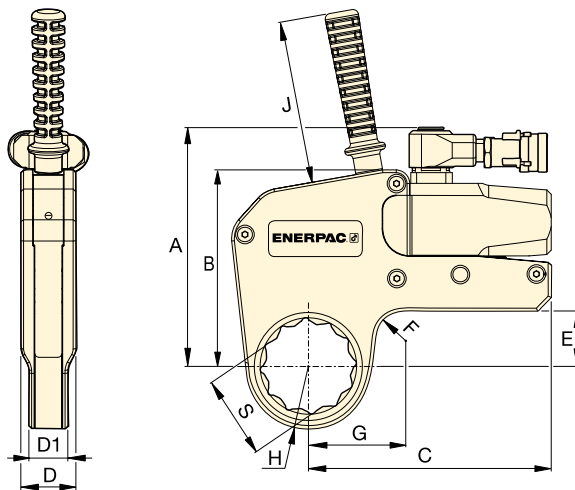

## SELECTION CHART

Bi-Hexagonal Size	Nominal Torque @ 690 bar	UltraSlim Cassette * Model Nr.	Minimum Torque @ 69 bar	Nose Radius	Dimensions (mm)										Drive Unit Model Nr. ** (sold separately)																		
					H	G	A	B	C	D	D1	E	F	J		(kg)																	
S (mm) (inch)	(Nm)		(Nm)	H (mm)	G	A	B	C	D	D1	E	F	J	(kg)																			
																46	1 <sup>3</sup> / <sub>16</sub>	2685	<b>W2113SL</b>	269	36,5	59,6	140,7	109,3	147,7	32,4	25,4	24,0	20,0	120	2,2		
																55	2 <sup>3</sup> / <sub>16</sub>	2685	<b>W2203SL</b>	269	41,5	63,2									2,2	<b>W2000PX</b>	
																60	2 <sup>3</sup> / <sub>8</sub>	2685	<b>W2206SL</b>	269	44,5	65,1									2,2		
																55	2 <sup>3</sup> / <sub>16</sub>	5911	<b>W4203SL</b>	591	44,0	68,7	175,6	144,5	178,5	40,5	28,6	40,8	20,0	120	4,6	<b>W4000PX</b>	
																60	2 <sup>3</sup> / <sub>8</sub>	5911	<b>W4206SL</b>	591	48,0	71,6											4,7
																65	2 <sup>3</sup> / <sub>16</sub>	5911	<b>W4209SL</b>	591	50,5	74,1											4,7
																70	2 <sup>3</sup> / <sub>4</sub>	5911	<b>W4212SL</b>	591	53,5	75,6											4,7
75	2 <sup>15</sup> / <sub>16</sub>	5911	<b>W4215SL</b>	591	56,0	76,0	4,7																										

\* Bi-Hexagonal Cassette includes top mounted straight handle.

\*\* Weight of drive unit W2000PX = 1,4 kg; W4000PX = 2,0 kg.

# WCR-Series, Roller Cassette Torque Wrench

▼ WCR4000 Roller Cassette with Spanner and W4000PX Drive Unit



- Provides a safe and reliable controlled bolting solution for flanges with limited access
- Spanners available to fit most commonly used API flanges
- Small nose radius – resolves bolt to pipe restrictions
- Slim spanner design – reduces bolt height restrictions
- Wide range of spanners ranging from 36 - 80 mm (1<sup>7</sup>/<sub>16</sub> - 3<sup>1</sup>/<sub>8</sub> inch)
- Includes handle to improve tool handling and safety
- Rigid steel body for maximum endurance and minimum downtime
- Enhanced tilt and swivel TSP300 manifold for horizontal and vertical maneuverability, with greater durability.

Bi-Hexagonal Spanner Size:

**36 - 80 mm, 1<sup>7</sup>/<sub>16</sub> - 3<sup>1</sup>/<sub>8</sub>"**

Spanner Nose Radius:

**31 - 55 mm**

Nominal Torque:

**5762 Nm (4250 Ft.lbs)**

Maximum Operating Pressure:

**690 bar**





### WCR-4000 Applications

The WCR4000 helps resolve narrow clearance restrictions in bolting of API and BOP flanges.

The Enerpac WCR4000 Roller Cassette has been developed for applications where there are severe clearance restrictions, particularly in height above the nut or between the bolt center and the inside of the joint.

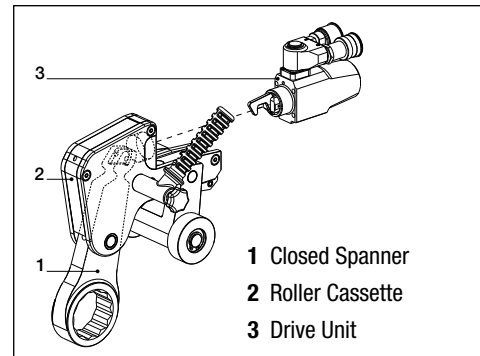
Powered by the standard W4000PX drive unit which is compatible with standard W-Series hexagon cassettes. The WCR-wrench must be removed and repositioned after each wrench cycle by operating the pump in the retract direction. The tool contains no spring return.



Closed Spanner Hexagon Size S (inch)   (mm)	Closed Spanner Model Number	Nominal Torque (Nm)	Spanner Radius R (mm)	 * (kg)	Roller Cassette Assembly Model Nr.	Drive Unit Model Nr.
1 <sup>7</sup> / <sub>16</sub>   36	W4107CS	5762	31	1,9	WCR4000	W4000PX
1 <sup>1</sup> / <sub>2</sub>   38	W4108CS	5762	33	2,0		
1 <sup>5</sup> / <sub>8</sub>   41	W4110CS	5762	33	1,9		
1 <sup>3</sup> / <sub>16</sub>   46	W4113CS	5762	36	1,9		
1 <sup>7</sup> / <sub>8</sub>   48	W4114CS	5762	38	2,1		
2   50	W4200CS	5762	38	1,9		
2 <sup>3</sup> / <sub>16</sub>   55	W4203CS	5762	41	2,0		
2 <sup>3</sup> / <sub>8</sub>   60	W4206CS	5762	45	2,1		
2 <sup>9</sup> / <sub>16</sub>   65	W4209CS	5762	47	2,1		
2 <sup>3</sup> / <sub>4</sub>   70	W4212CS	5762	50	2,1		
2 <sup>15</sup> / <sub>16</sub>   75	W4215CS	5762	52	2,1		
3 <sup>1</sup> / <sub>8</sub>   80	W4302CS	5762	55	2,2		

\* Spanner weight. For total weight add 6,3 kg for WCR4000 and 2,0 kg for W4000PX.

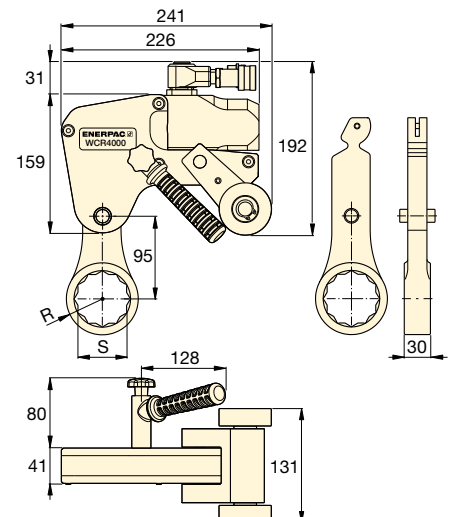

# Accessories for W-Series, X-Edition Wrenches

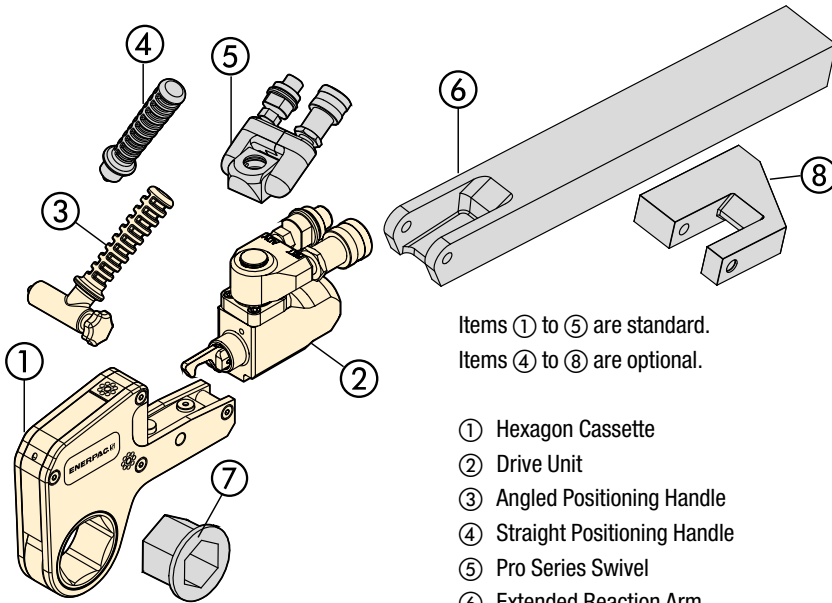

Items ① to ⑤ are standard.  
Items ④ to ⑧ are optional.

- ① Hexagon Cassette
- ② Drive Unit
- ③ Angled Positioning Handle
- ④ Straight Positioning Handle
- ⑤ Pro Series Swivel
- ⑥ Extended Reaction Arm
- ⑦ Reducer Insert
- ⑧ Reaction Paddle

## WTE WRP Series



### WTE-Series, Extended Reaction Arm

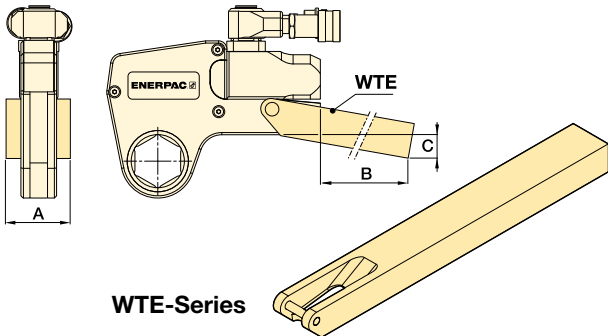

- Full torque rated
- Increases tool fit in restricted access areas.

For Torque Wrench Model Number	Model Number	Dimensions (mm)			Weight (kg) *
		A	B	C	
W2000PX	WTE20	56	398	76	2,6
W4000PX	WTE40	66	436	74	4,6
W8000PX	WTE80	85	449	55	7,6
W15000PX	WTE150	102	498	72	12,0
W22000PX	WTE220	114	524	77	17,3
W35000PX	WTE350	127	419	133	17,8

\* Weights indicated are for the accessories only and do not include the wrench.

### WRP-Series, Low Profile Reaction Paddles

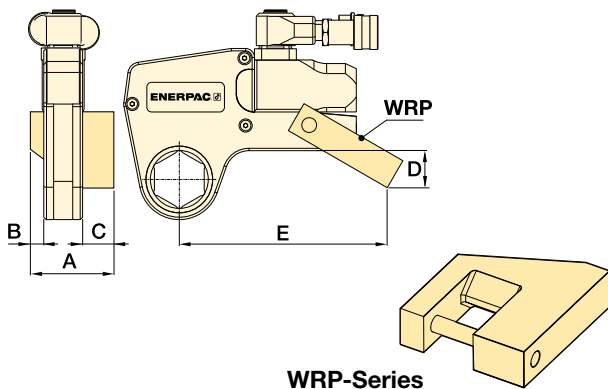

- Lightweight interchangeable design
- Allows for offset reaction when in-line reaction is not available.

For Torque Wrench Model Nr.	Model Number	Dimensions (mm)					Weight (kg) *
		A	B	C	D	E	
W2000PX	WRP20	84	16	35	45	148	0,4
W4000PX	WRP40	109	21	47	59	190	0,8
W8000PX	WRP80	137	26	57	69	223	2,0
W15000PX	WRP150	165	32	69	87	257	3,9
W22000PX	WRP220	207	37	91	134	317	7,2
W35000PX	WRP350	225	42	91	182	367	10,6

\* Weights indicated are for the accessories only and do not include the wrench.



▼ PTW1000



## Productivity

- High speed continuous rotation for constant torque output
- Low friction planetary gearbox design minimizes wear and extends uptime.

## Safety

- Ergonomic, low vibration design reduces fatigue and the risk of vibration related injuries for the operator
- Low noise air motor provides quiet, consistent performance for indoor and outdoor applications.

## Convenience

- Provided with standard reaction arm; wide assortment of custom arms and accessories are available
- Available with or without Filter-Regulator-Lubricator (FRL)
- Unique calibration certificate provided with each tool.



◀ The PTW1000 makes quick work of this flange maintenance job.

## Continuous Rotation Controlled Torque



### Calibration Certificate

All PTW-Series tools are CE declared and are shipped complete with a calibration certificate.



### Typical Pneumatic Torque Wrench Applications

#### Oil and Gas, MRO

- Pipe flanges
- Valves
- Man-way covers
- Pressure vessels.

#### Power Generation

- Turbine bolts
- Tower segments
- Turbine casings.

#### Mining

- Track maintenance
- Undercarriage maintenance
- Wheel maintenance
- Shovel maintenance.

▼ PTW-Series Pneumatic Torque Wrenches are ideal for applications where speed and precision are critical, such as track maintenance.



# Pneumatic Torque Wrenches



## PTW-Series, Pneumatic Torque Wrenches

Enerpac PTW-Series Pneumatic Torque Wrenches are designed for applications that require speed and control.

The standard package includes a Torque Wrench with a calibration certificate, an FRL (Filter/Regulator/Lubricator), and a 3 m long, ½" inch (13 mm) diameter air hose, which connects the FRL to the wrench.

Once the air hoses are connected, the operator simply adjusts the air pressure on

the FRL to achieve the desired torque using the calibration certificate. After this, the tool is ready to go to work! \*

The air source used with the PTW system must be regulated and/or limited to 8,3 bar, and must be capable of providing a volume of at least (85 m³/h) at 6,9 bar. A separate ½" inch hose (not included) must be used to connect the FRL to the air supply.

\* See instruction manual for comprehensive instructions.

## PTW Series



Nominal Torque Output:

**8135 Nm**

Square Drive Range:

**1 - 1½ inch**

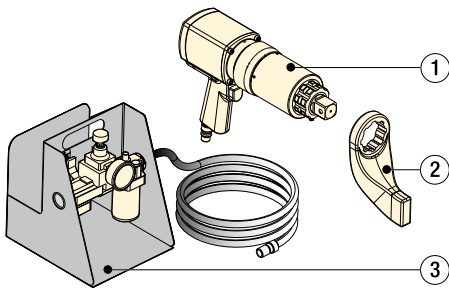

- ① PTW Torque Wrench
- ② Standard Reaction Arm
- ③ FRL120C Filter-Regulator-Lubricator with 3 meters air hose

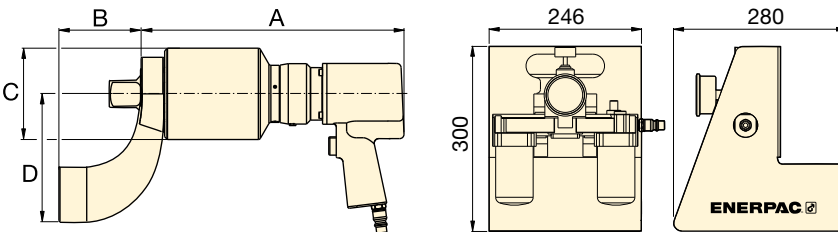

### Accessories

Enerpac offers a full line of accessories including a range of reaction arms and drives.

Page: **210**



### FRL120C, Filter-Regulator-Lubricator with air hose

All PTW-Series tools are shipped complete with standard reaction arm, and Filter-Regulator-Lubricator (FRL120C).



### BSH-Series Sockets

Heavy-Duty Impact Sockets for power driven torquing equipment.

Page: **190**



### Hydraulic Torque Wrenches

Enerpac offers a complete range of square drive and hexagon cassette torque wrenches.

## ▼ SELECTION CHART

All tools are shipped complete with standard reaction arm and FRL120C.

Minimum Torque		Nominal Torque		Square Drive (inch)	Model Number <sup>1)</sup> (FRL120C included)	Speed (RPM)	Dimensions (mm)				Weight (kg) <sup>2)</sup>
(Nm)	(Ft.lbs)	(Nm)	(Ft.lbs)				A	B	C	D	
407	300	1356	1000	1	<b>PTW1000C</b>	12,6	272	83	72	130	8,2
678	500	2712	2000	1	<b>PTW2000C</b>	8,0	286	83	79	133	8,8
1220	900	4067	3000	1	<b>PTW3000C</b>	3,1	343	83	95	133	10,4
1763	1300	8135	6000	1½	<b>PTW6000C</b>	2,5	366	114	127	178	17,7

<sup>1)</sup> To order without FRL120C, remove "C" suffix from model number (example: **PTW3000**).

<sup>2)</sup> Weight does not include reaction arm. Reaction arm weight for PTW1000, PTW2000, PTW3000 is 1,3 kg and for PTW6000 is 3,5 kg.

▼ TW3000EI (torque wrench shown without servo motor cable)



## Versatility

- Patented firmware design provides accurate fastening on soft or pre-tightened joints when accuracy is critical
- Single control box may be used to operate multiple wrench models
- Wrenches and control boxes may be purchased separately or as a calibrated set

## Performance

- High speed continuous rotation gets the job done faster
- Torque and angle functionality allows input of nominal torque value followed by a specific angle of rotation
- Pass/Fail LED indicator on back of tool verifies fastening has been completed according to specified input.

## Simplicity

- Control box with 7-inch touchscreen simplifies tool operation
- Controls on back of wrench enable operator to monitor and manage the fastening process without returning to the control box
- Brightly lit three line LED display on wrench is easy to read in any environment, even in bright sunlight.

## Traceability

- Fastening record can be viewed on-screen and transferred through standard USB connection on the control box
- Each tool is performance tested and shipped complete with a factory calibration certificate.

## Safety

- Lift points on wrench enable use with positioning handle or lifting device for greater handling safety
- Ground fault detector protects operator in the event of insufficient grounding.

## Your Simple Solution for Smart Bolting



### Touchscreen Control Box

ETW-Series tools feature an easy to use, interactive touch-screen control box, which helps make even the most complex jobs simple to complete.

Single control box may be used to operate multiple wrench models.

Firmware upgrades may be uploaded online and easily transferred to the tool via a USB connection.



### Easy Access to Controls

Controls on back of wrench with LED display allow user to directly input desired torque, change direction of rotation, and monitor the fastening process.



### Certifications and Declarations

All ETW-Series tools:

- Are CE declared
- Are shipped complete with a calibration certificate
- Are certified for North American Electrical Safety by CSA International
- Carry a CSA US and Canada mark.



▼ *ETW-Series Electric Torque Wrenches are ideal for high volume fastening applications that require precision and traceability, such as this wind tower job.*





## ETW-Series, Electric Torque Wrenches

Enerpac ETW-Series Electric Torque Wrenches are particularly well suited to complex jobs which demand precision and traceability.

The ETW-Series tools feature an automatic mode, which helps simplify and automate complex jobs, including those with torque and angle specifications, through the creation of presets.

Using the touchscreen, simply input the number of fasteners and desired torque value for each fastening step, followed by the required angle of turn. This sequence may then be saved as an automatic preset for future use.

For simpler jobs, torque values may be input with a digital slider on the touchscreen, or directly into the rear control panel of the wrench.

Once the input torque is achieved, the tool stalls, and a pass/fail indicator verifies that it is ready to move on to the next fastener.

When the job is completed, the fastening record can be viewed on the touch screen, or exported to a computer via a USB connection on the control box.

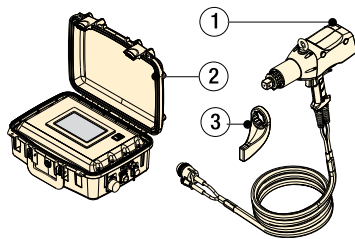

### ETW-Set

- ① ETW Torque Wrench with 6m servo motor cable
- ② Control Box with 2m power cord
- ③ Standard Reaction Arm

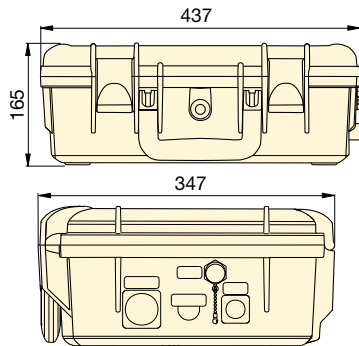
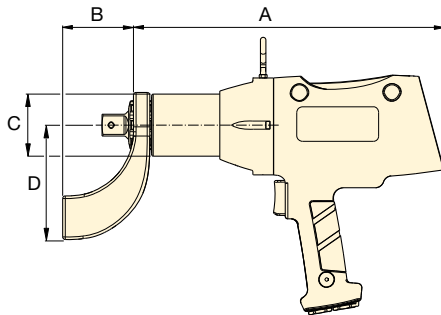

ETW-torque wrench

ETWCB-control box

Minimum Torque		Nominal Torque		Square Drive (inch)	ETW-Set Model Number	ETW-Set includes		Voltage	Nominal Speed (RPM)	Dimensions (mm)				Weight (kg) <sup>1)</sup>
(Nm)	(Ft.lbs)	(Nm)	(Ft.lbs)			Wrench Model Nr. <sup>2)</sup>	Control Box Model Nr. <sup>2)</sup>			A	B	C	D	
270	200	1355	1000	1	ETW1000B	TW1000B	ETWCB-B	115V 60 Hz	9,8	365	83	72	130	8,2
270	200	1355	1000	1	ETW1000I	TW1000EI	ETWCB-I	230V 60 Hz	15,2	365	83	72	130	8,2
270	200	1355	1000	1	ETW1000E	TW1000EI	ETWCB-E	230V 50 Hz	15,2	365	83	72	130	8,2
540	400	2710	2000	1	ETW2000B	TW2000B	ETWCB-B	115V 60 Hz	5,8	380	83	79	133	8,9
540	400	2710	2000	1	ETW2000I	TW2000EI	ETWCB-I	230V 60 Hz	9,0	380	83	79	133	8,9
540	400	2710	2000	1	ETW2000E	TW2000EI	ETWCB-E	230V 50 Hz	9,0	380	83	79	133	8,9
810	600	4065	3000	1	ETW3000B	TW3000B	ETWCB-B	115V 60 Hz	2,8	436	83	95	133	11,9
810	600	4065	3000	1	ETW3000I	TW3000EI	ETWCB-I	230V 60 Hz	4,3	436	83	95	133	11,9
810	600	4065	3000	1	ETW3000E	TW3000EI	ETWCB-E	230V 50 Hz	4,3	436	83	95	133	11,9
1625	1200	8135	6000	1½	ETW6000B	TW6000B	ETWCB-B	115V 60 Hz	1,9	453	114	127	178	19,1
1625	1200	8135	6000	1½	ETW6000I	TW6000EI	ETWCB-I	230V 60 Hz	2,9	453	114	127	178	19,1
1625	1200	8135	6000	1½	ETW6000E	TW6000EI	ETWCB-E	230V 50 Hz	2,9	453	114	127	178	19,1

<sup>1)</sup> Wrench weight does not include reaction arm. Standard reaction arm weight for ETW1000, ETW2000, ETW3000 is 1,3 kg and for ETW6000 is 3,5 kg. Standard reaction arm included with TW-model. Weight of the control box is 9 kg.

<sup>2)</sup> Use of ETW requires both wrench and control box. These may be purchased separately, or as a calibrated set.

## ETW Series



Nominal Torque Output:

**8135 Nm**

Square Drive Range:

**1 - 1½ inch**



### Accessories

Enerpac offers a full line of accessories including a range of reaction arms and drives.

Page: **210**



### BSH-Series Sockets

Heavy-Duty Impact Sockets for power driven torquing equipment.

Page: **190**

**Voltage: (Model Number ending with suffix)**

**B** = 115V, 60 Hz

**I** = 230V, 60 Hz (with NEMA 6-15 plug)

**E** = 230V, 50 Hz (with commonly used European (SCHUKO) plug)

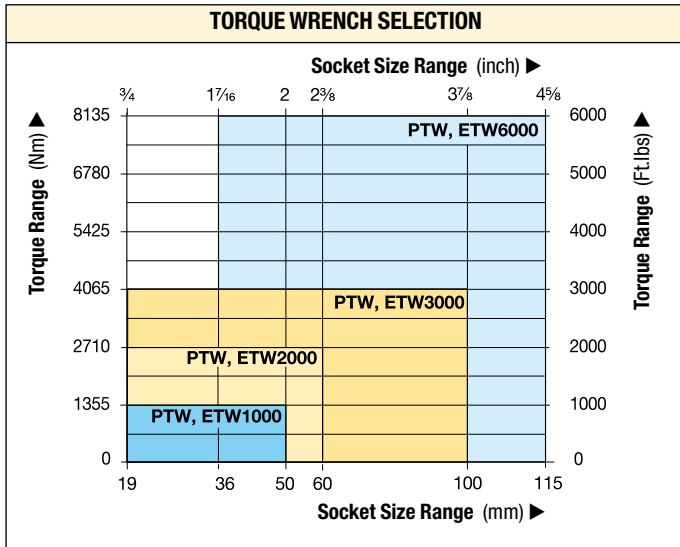

## PTW, ETW Series



Nominal Torque Output:

**8135 Nm**

Square Drive Range:

**1 - 1½ inch**

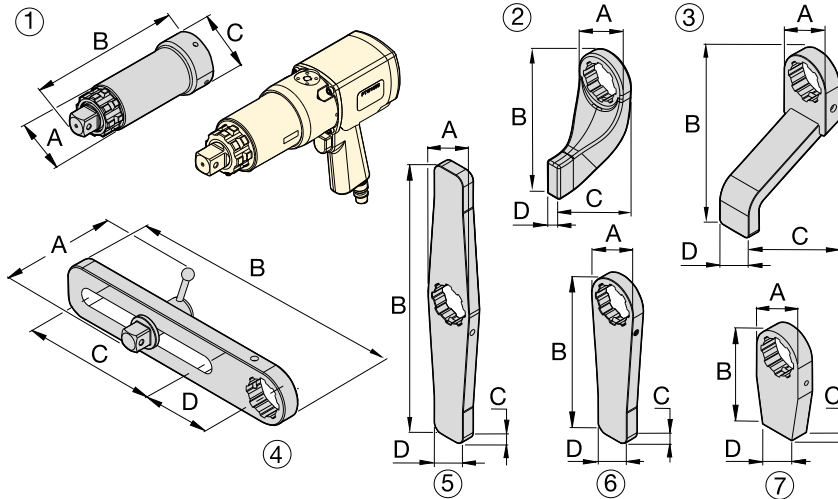

### BSH-Series Sockets

Heavy-Duty Impact Sockets for power driven torquing equipment.

Page: **190**

### Optional Accessories

#### For use with PTW and ETW1000, 2000, 3000-models

Nr.	Description	Model Nr.	Application	Dimensions (mm)			
				A	B	C	D
1	Extended Drive, 6 inch (152 mm)	ED6TWS	Nose extension, primarily for truck wheel bolts	62	206	73	–
1	Extended Drive, 12 inch (305 mm)	ED12TWS	Nose extension, primarily for truck wheel bolts	62	384	73	–
1	Extended Drive, 18 inch (457 mm)	ED18TWS	Nose extension, primarily for truck wheel bolts	62	511	73	–
2	Standard Reaction Arm	RATWS	Standard arm included with PTW and ETW model	76	172	102	21
3	Extended Reaction Arm	ERATWS	Long plate for use with deep well sockets	73	150	202	51
4	Sliding Reaction Arm	SLRATWS	For widely spaced and uneven bolt centers	112	381	203	102
5	Double Straight Reaction Arm	DSATWS	Reduces time to reposition arm *	73	406	19	102
6	Straight Reaction Arm	SRATWS	Long plate for wide spaced reaction points	73	240	19	51
7	Blank Reaction Arm **	BLTWS	Weldable blank for custom applications **	72	151	25	51

#### For use with PTW and ETW6000-models

1	Extended Drive 6 inch (152 mm)	ED6TWL	Nose extension, primarily for truck wheel bolts	84	232	102	–
1	Extended Drive 12 inch (305 mm)	ED12TWL	Nose extension, primarily for truck wheel bolts	84	384	102	–
2	Standard Reaction Arm	RATWL	Standard arm included with PTW and ETW model	102	229	146	32
3	Extended Reaction Arm	ERATWL	Long plate for use with deep well sockets	102	254	184	64
4	Sliding Reaction Arm	SLRATWL	For widely spaced and uneven bolt centers	152	419	190	114
5	Double Straight Arm	DSATWL	Reduces time to reposition arm *	102	508	32	57
6	Straight Reaction Arm	SRATWL	Long plate for wide spaced reaction points	102	305	32	57
7	Blank Reaction Arm **	BLTWL	Weldable blank for custom applications **	102	152	32	57

\* Time to reposition arm when repeatedly moving from tightening to loosening.

\*\* WARNING: Blank reaction arms must be heat treated to HRc 38-42 prior to use.

# Typical PTW and ETW-Series Torque Wrench Applications

## Mining

- Track maintenance
- Undercarriage maintenance
- Wheel maintenance
- Shovel maintenance



## Power Generation

- Turbine bolts
- Tower segments
- Turbine casings



















## Oil & Gas

- Pipe flanges
- Valves
- Manway covers
- Pressure vessels



## Optimum Torque Wrench and Pump Combinations

For optimum speed and performance Enerpac recommends the following system set-up with wrench-pump-hose combinations. For other combinations, consult your Enerpac bolting expert or your authorized Enerpac distributor.

		ELECTRIC PUMPS				AIR DRIVEN PUMPS
		PME, PMU-Series	ZU4-Series	TQ-Series	ZE-Series	ZA4-Series
						
		Page: 213	Page: 216	Page: 214	Page: 220	Page: 222
<b>Speed:</b>						
<b>Reservoir Capacity:</b>		1,9 - 3,8 litres	4,0 - 8,0 litres	4,0 litres	4,0 - 40 litres	4,0 - 8,0 litres
<b>Duty Cycle:</b>		Standard	Standard	Medium	Heavy-Duty	Heavy-Duty
<b>Weight:</b>						
<b>Field/Factory Work:</b>		Field	Field	Field/Factory	Factory	Field
<b>S-Series</b>		S1500PX	Optimal	Optimal	Optimal	Optimal
		S3000PX				
		S6000PX				
		S11000PX		-		
		S25000PX				
<b>W-Series</b>		W2000PX	Optimal	Optimal	Optimal	Optimal
		W4000PX				
		W8000PX				
		W15000PX		-		
		W22000PX				
	W35000PX					



### ZU4T – Electric Wrench Pumps

Utilizing a universal motor, the ZU4-Series has excellent low voltage characteristics.

It works well with long extension cords or generator driven electrical power supplies.

A field proven, efficient design ensures this pump is dependable and will draw less current – lowering your operating cost. ZU4-pumps are available in Pro and Classic formats.

**ZU4T Pro pumps** have an LCD feature to display torque or pressure, selectable torque wrench, and self-diagnostics – premium features not available on any other pump.

**ZU4T Classic pumps** feature an analogue gauge and a basic electrical package to deliver durable, safe and efficient hydraulic power.

### ZE-Series Electric Wrench Pumps

The ZE-Series features premium options, such as the LCD to display torque or pressure values, and self-diagnostics. These pumps utilize an induction motor, making the ZE-Series the coolest and quietest pumps in their class.

### ZA4T-Series Air Driven Wrench Pumps

Utilizing the highly efficient design of the Z-Class pumping element, this air driven pump is best suited to power medium to large size torque wrenches.

### TQ-700 Series Electric Wrench Pumps

Designed for both portability and production, the TQ-700 features optimized flow technology to deliver superior bolting speed.



### Torque Wrench Hoses

Use Enerpac twin safety hoses to connect your torque wrench to the pump.

For S & W	Modelnr.
6 m long, 2 hoses	THQ-706T
12 m long, 2 hoses	THQ-712T



### Torque Wrench Couplers

For torque wrench couplers see our "System Components" section in this catalogue.

Page: 116

# Portable Electric Torque Wrench Pumps

▼ PMU-10422Q



- Powerful two-speed pump is lightweight and easy to carry
- Standard heat exchanger package on PMU-Series keeps pump cool under extreme use
- Glycerin filled gauge with scales reading in psi and bar
- Transparent overlays in Nm and Ft.lbs for all Enerpac torque wrenches provide a quick torque reference
- Universal motor for a high power-to-weight ratio; generates full pressure on as little as 50% of the rated line voltage
- Adjustable pressure relief valve for accurate torque adjustments and precise repeatability.

## PME PMU Series



Reservoir Capacity:

**1,9 - 3,8 litres**

Flow at Rated Pressure:

**0,33 l/min**

Motor Size:

**0,37 kW**

Maximum Operating Pressure:

**700 bar**



### Torque Wrench Hoses

Use Enerpac twin safety hoses to connect your torque wrench to the pump.

For 700 bar	Modelnr.
6 m long, 2 hoses	THQ-706T
12 m long, 2 hoses	THQ-712T



### Gauge and Overlay Kit

Available separately for use with PMU-Series pumps: **GT-4015Q** includes gauge and overlays for all S- and W-Series wrenches.

## ▼ SELECTION CHART

For Use With Torque Wrenches		Maximum Pressure Rating (bar)		Oil Flow Rate (l/min)		Model Number with Heat Exchanger *	Useable Oil Capacity (litres)	Electric Motor (Volt-phase-Hz)	Dimensions L x W x H (mm)	Weight (kg)
		1 <sup>st</sup> stage	2 <sup>nd</sup> stage	1 <sup>st</sup> stage	2 <sup>nd</sup> stage					
S1500PX	W2000PX	48	700	3,3	0,33	PMU-10427Q	1,9	115 - 1 - 50/60	431x280x381	21
	S3000PX	W4000PX	48	700	3,3	0,33	PMU-10447Q	3,8	115 - 1 - 50/60	431x330x381
S3000PX		W4000PX	48	700	3,3	0,33	PMU-10422Q	1,9	230 - 1 - 50/60	431x280x381
	48		700	3,3	0,33	PMU-10442Q	3,8	230 - 1 - 50/60	431x330x381	24

\* For pump without heat exchanger change PMU into PME. Example **PME-10442Q**.  
PME-Series pump size: 250 x 250 x 360 mm. Weight 18 kg (1,9 litres) and 21 kg (3,8 litres).



▼ TQ-700E



- Optimized flow technology – three stage pump maximizes productivity of the pump and tool while minimizing heat build-up and down time
- Heat exchanger is standard included
- A quiet (<85 dBA), lightweight pump with a compact footprint – easy to move around and through the work site
- Durable roll cage with an ergonomically sized handle and shielded gauge – a pump that is easy to put into position and safe from on site operational hazards
- Maintenance made simple with a brushless motor designed for continuous usage
- Straightforward operation with a simple pressure set and convenient to use 6 m pendant control – immediate productivity for crews operating the pump
- IP55 Rating for Superior Dust and Water Protection
- Transparent gauge overlays in Nm and Ft.lbs for all Enerpac S and W-Series torque wrenches provide a quick torque reference.

## Lightweight Torque Wrench Pumps



### Four Port Manifold

The TQ-700 offers an optional four wrench manifold as an accessory factory installed. (Add suffix "M" at the end of the model number.

For example: **TQ-700EM**).



### Hydraulic Torque Wrenches

Enerpac offers a complete range of square drive and hexagon cassette torque wrenches.

Page: **183**



### Torque Wrench Hoses

Use Enerpac THQ-700 series twin hoses with 700 bar pumps.

For 700 bar	Model Nr.
6 meters long, 2 hoses	<b>THQ-706T</b>
12 meters long, 2 hoses	<b>THQ-712T</b>



◀ The TQ-700E and the W-Series wrenches are a productive combination in wind applications.

# Electric Torque Wrench Pumps



## TQ-700 Applications

The TQ-700 Series pump is ideal for powering hydraulic wrenches for the Power Generation and Wind Markets.

Bolting speed is more complex than how much flow per minute the pump produces. The key is optimising the flow rate across the entire bolting cycle. With more oil flowing at the right time and at the right volume, you achieve the optimized flow for a hydraulic bolting system.

The result of this optimized flow is more bolts tightened faster and a more productive work team.

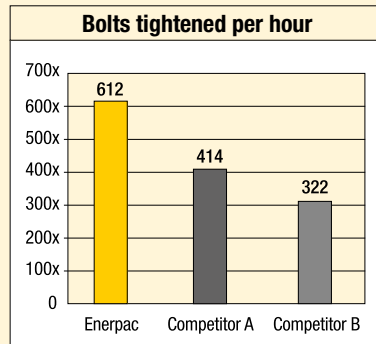

Internal laboratory testing based on standard torquing procedure on a pipe flange with 14, 1 7/8" bolts.

## TQ Series



Reservoir Capacity:  
**4,0 litres**

Flow at Rated Pressure:  
**0,5 l/min**

Motor Size:  
**0,75 kW**

Maximum Operating Pressure:  
**700 bar**



## Torque Wrench Pump Selection Matrix

For optimum speed and performance see the torque wrench, pump and hose selection matrix.

Page: 212

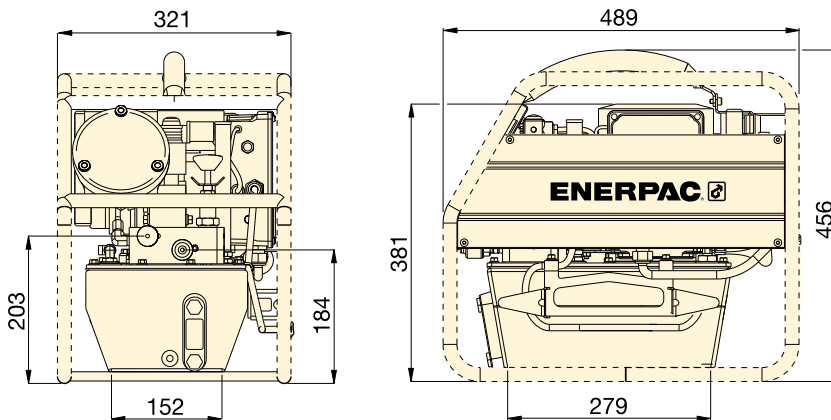

For Use with Torque Wrenches	Pressure Rating (bar)	Model Number <sup>1)</sup>	Useable Oil Capacity (litres)	Motor Size (kW)	Motor Electrical Specifications (Volt - Ph - Hz)	Sound Level (dBA)	Weight (kg)
All S and W-Series	700	<b>TQ-700B</b>	4,0	0,75	115 - 1 - 50/60	82 - 85	31
	700	<b>TQ-700E</b> <sup>2)</sup>	4,0	0,75	230 - 1 - 50	82 - 85	30
	700	<b>TQ-700I</b> <sup>3)</sup>	4,0	0,75	230 - 1 - 60	82 - 85	30

<sup>1)</sup> All models meet CE safety requirements and all TÜV requirements.

<sup>2)</sup> TQ-700E with European plug and CE EMC directive compliant.

<sup>3)</sup> TQ-700I with NEMA 6-15 plug.

▼ The TQ-700E and the W-Series wrenches are a productive combination.



# ZU4T-Series, Electric Torque Wrench Pumps

**ENERPAC**   
POWERFUL SOLUTIONS. GLOBAL FORCE.

▼ ZU4204TE-Q (Pro-Series), ZU4204BE-Q (Classic)



# Z

Tough,  
Dependable  
Innovative  
**CLASS**



### Classic Electrical

Basic electrical package includes mechanical contactor, ON/OFF toggle switch, pendant with electro-mechanical push buttons, 24V transformer timer and operator accessible circuit breaker.



### Pro-Series

Back-lit LCD and Pressure Transducer featuring Auto-Cycle Technology.

- Features Z-Class high-efficiency pump design; higher oil flow and bypass pressure, cooler running and requires 18% less current draw than comparable pumps
- Powerful 1,25 kW universal electric motor provides high power-to-weight ratio and excellent low-voltage operating characteristics
- High-strength, molded composite shroud protects motor and electrical components, while providing an ergonomic, non-conductive handle for easy transport
- Low-voltage pendant provides additional safety for the operator.

### Pro Series pump only

- LCD readout provides pressure display and a number of diagnostic and readout capabilities never before offered on a portable electric pump
- AutoCycle feature provides continuous cycle operation of the torque wrench as long as the advance button is pressed (pump can be used with or without auto cycle feature).

- Torque wrench model is selectable
- "Auto cycle" setting easily programmable.
- Digital read-out and "Autocycle" setting
- Pump usage information, hour and cycle counts
- Low-voltage warning and recording
- Self-test and diagnostic capabilities
- Information can be displayed in English, French, German, Italian, Spanish and Portuguese
- Pressure transducer is more accurate and durable than analog gauges
- Easy-viewing variable rate display
- Display pressure in bar, MPa or psi.



◀ Any brand of hydraulic torque wrench can be powered by the portable ZU4-Series torque wrench pump.

# ZU4T-Series, Torque Wrench Pumps



## Z-Class – A Pump For Every Application

Patented Z-Class pump technology provides high bypass pressures for increased productivity – important in applications using long hose runs and high pressure-drop circuits, like heavy lifting or certain double-acting tools.

Enerpac ZU4T-Series pumps are built to power small to large torque wrenches. Choosing the right ZU4T-Series torque wrench pump for your application is easy.

### Classic Electric Torque Wrench Pump

- The Classic has traditional electro-mechanical components (transformers, relays and switches) in place of solid-state electronics. The Classic delivers durable, safe and efficient hydraulic power.

### Pro Series Electric Torque Wrench Pump

- Digital (LCD) display features a built-in hour meter, pressure display and shows self-diagnostic, cycle-count and low voltage warning information. These premium features are not available on any other pump – anywhere!
- Auto-Cycle feature provides continuous cycle operation of the torque wrench as long as the advance button is pressed (pump can be used with or without Auto-Cycle feature).

## ZU4T Series



Reservoir Capacity:

**4,0 - 8,0 litres**

Flow at Rated Pressure:

**1,0 l/min**

Motor Size:

**1,25 kW**

Maximum Operating Pressure:

**700 bar**

OIL FLOW VERSUS PRESSURE

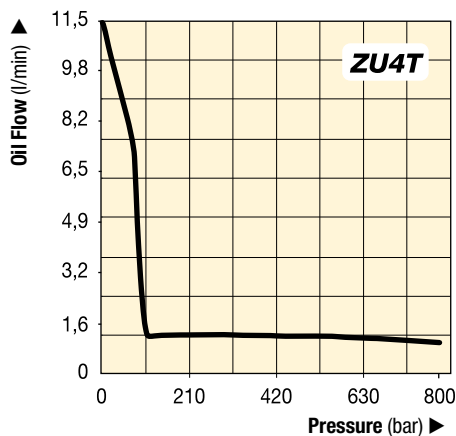

### Torque Wrench Pump Selection Matrix

For optimum speed and performance see the torque wrench pump and hose selection matrix.

Page: 212



### Gauge and Overlay Kit

Available separately for use with ZU4T-Series Classic: **GT-4015Q** includes gauge and overlays for all S- and W-Series torque wrenches.

### COMMON PUMP MODELS

	For Use With Torque Wrenches	Model Number <sup>1)</sup>	Motor Electrical Specification	Usable Oil Capacity (litres)	Weight (kg)
Pro Series	All wrenches	ZU4204TB-Q	115 VAC, 1-ph	4,0	32
		ZU4208TB-Q	115 VAC, 1-ph	8,0	34
		ZU4204TE-Q <sup>2)</sup>	208-240 VAC, 1-ph	4,0	32
		ZU4208TE-Q <sup>2)</sup>	208-240 VAC, 1-ph	8,0	34
		ZU4204TI-Q <sup>3)</sup>	208-240 VAC, 1-ph	4,0	32
		ZU4208TI-Q <sup>3)</sup>	208-240 VAC, 1-ph	8,0	34
Classic	All wrenches	ZU4204BB-QH	115 VAC, 1-ph	4,0	37
		ZU4204BB-Q	115 VAC, 1-ph	4,0	33
		ZU4208BE-QH <sup>2)</sup>	208-240 VAC, 1-ph	8,0	38
		ZU4204BE-Q <sup>2)</sup>	208-240 VAC, 1-ph	4,0	34
		ZU4208BI-QH <sup>3)</sup>	208-240 VAC, 1-ph	8,0	40
		ZU4208BI-Q <sup>3)</sup>	208-240 VAC, 1-ph	8,0	36

<sup>1)</sup> All models meet CE safety requirements and all CSA requirements.

<sup>2)</sup> European plug and CE EMC directive compliant

<sup>3)</sup> With NEMA 6-15 plug



### 4-Wrench Manifold

- For simultaneous operation of multiple torque wrenches
- Can be factory installed or ordered separately.

Accessory Kit * Model Nr.	Can be used on ZU4-Series torque wrench pumps
ZTM-Q	for 700 bar torque wrenches

\* Add suffix **M** for factory installation.  
**Ordering Example: ZU4208TE-QM**



### Skid Bar

- Provides greater pump stability on soft or uneven surfaces
- Provides easy two-handed lift.

Accessory Kit * Model Nr.	Can be used on ZU4-Series torque wrench pumps
SBZ-4	4 and 8 litres reservoir <sup>1)</sup>
SBZ-4L	4 and 8 litres reservoir <sup>2)</sup>

\* Add suffix **K** to pump model number for factory installation.

- <sup>1)</sup> Without heat exchanger 2,2 kg.  
<sup>2)</sup> With heat exchanger 3,2 kg.

**Ordering Example: ZU4208TE-QK**



### Heat Exchanger

- Removes heat from the bypass oil to provide cooler operation
- Stabilizes oil viscosity, increasing oil life and reduces wear of pump and other hydraulic components.

Accessory Kit * Model Nr.	Can be used on ZU4-Series torque wrench pumps
ZHE-U115	115 V pumps
ZHE-U230	230 V pumps

\* Add suffix **H** to pump model number for factory installation.

Heat Exchanger adds 4,1 kg to pump weight.  
**Ordering Example: ZU4208TE-QH**

▼ Most hydraulic torque wrenches can be powered by the Enerpac ZU4T-Series torque wrench pump.



### Roll Cage

- Protects pump
- Provides greater pump stability.

Accessory Kit * Model Nr.	Can be used on ZU4-Series torque wrench pumps
ZRC-04	4 and 8 litres reservoir <sup>1)</sup>
ZRC-04H	4 and 8 litres reservoir <sup>2)</sup>

\* Add suffix **R** for factory installation.

- <sup>1)</sup> Without heat exchanger.  
<sup>2)</sup> With heat exchanger.

**Ordering Example: ZU4208TE-QR**

Thermal Transfer *	Max. Pressure	Max. Oil Flow	Voltage
(Btu/h)	(bar)	(l/min)	(VDC)
900	20,7	26,5	12

\* At 1,9 l/min at 21 °C ambient temperature. Do not exceed maximum oil flow and pressure ratings. Heat exchanger is not suitable for water-glycol or high water-based fluids.

# ZU4T-Series, Ordering Matrix and Specifications

▼ This is how a ZU4T-Series pump model number is built up:

<b>Z</b>	<b>U</b>	<b>4</b>	<b>2</b>	<b>08</b>	<b>T</b>	<b>E</b>	<b>-</b>	<b>Q</b>	<b>H</b>	<b>M</b>
1 Product Type	2 Motor Type	3 Flow Group	4 Valve Type	5 Reservoir Size		7 Voltage		8 Must be E or Q	8 Options	8 Options

## 1 Product Type

**Z** = Pump series

## 2 Motor Type

**U** = Universal electric motor

## 3 Flow Group

**4** = 1,0 l/min @ 700 bar

## 4 Valve Type

**2** = Torque wrench valve

## 5 Reservoir Size (useable oil)

**04** = 4 litres

**08** = 8 litres

## 6 Valve Operation

**T** = **Pro Series** pump with solenoid valve and pendant, LCD Electric and pressure transducer

**B** = **Classic pump** with solenoid valve and pendant.

## 7 Voltage

**B** = 115V, 1 ph, 50/60 Hz

**E** = 208-240V, 1 ph, 50/60 Hz (with European plug CE RF compliant)

**I** = 208-240V, 1 ph, 50/60 Hz (with NEMA 6-15 plug)

## 8 Options

**Q** = **700 bar couplers** for use with S and W-Series or other wrenches

**H** = Heat exchanger

**K** = Skid bar

**M** = 4-wrench manifold

**R** = Roll cage

## ZU4T Series



Reservoir Capacity:

**4 - 8 litres**

Flow at Rated Pressure:

**1,0 l/min**

Motor Size:

**1,25 kW**

Maximum Operating Pressure:

**700 bar**



**How to order your ZU4T-Series torque wrench pump**

### Ordering Example : Modelnr. ZU4208TE-QMHK

Pro Series pump for use with Enerpac S and W-Series and other 700 bar torque wrenches, 230V motor, 8 litres reservoir, 4-wrench manifold, heat exchanger and skidbar.

Refer to the torque wrench pump selection matrix for optimum wrench, pump and hose combinations.

Page: 212

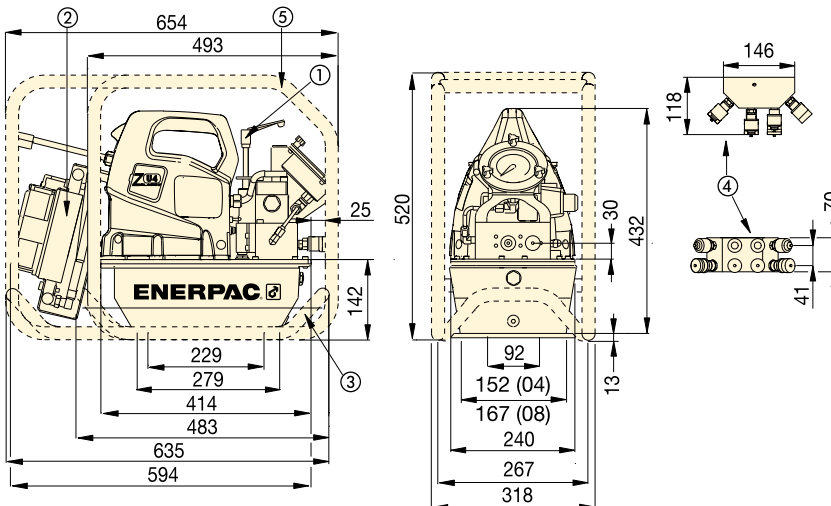

### ZU4T-Series Torque Wrench Pumps

- ① User adjustable relief valve
- ② Heat Exchanger (optional)
- ③ Skidbar (optional)
- ④ 4-wrench manifold (optional)
- ⑤ Roll cage (optional)

Motor Size (kW)	Output Flow Rate (l/min)				Motor Electrical Specification (Volt - Phase - Hz)	Sound Level (dBA)	Relief Valve Adjustment Range (bar)
	7 bar	50 bar	350 bar	700 bar			
1,25	11,5	8,8	1,2	1,0	115 - 1 - 50/60 208-240 - 1 - 50/60	85-90	124-700 *



### Torque Wrench Hoses

Use Enerpac twin safety hoses to connect your torque wrench to the pump.

For 700 bar	Model-Nr.
6 m long, 2 hoses	THQ-706T
12 m long, 2 hoses	THQ-712T

# ZE-Series, Electric Torque Wrench Pumps

**ENERPAC**   
POWERFUL SOLUTIONS. GLOBAL FORCE.

▼ ZE4204TE-QHR



**Z** Tough,  
Dependable  
Innovative  
**CLASS**

- Auto-Cycle feature provides continuous cycle operation of the torque wrench as long as the advance button is pressed (pump can be used with or without auto cycle feature)
- LCD readout provides pressure and torque display and a number of diagnostic and readout capabilities never before offered on a portable electric pump
- Totally enclosed, fan-cooled industrial electric motors supply extended life and stand up to harsh industrial environments
- High-strength, molded electrical enclosure protects electronics, power supplies and LCD readout from harsh environments.



#### Pro-Series

Back-lit LCD and Pressure Transducer featuring Auto-Cycle Technology.

- Torque wrench model is selectable
- "Auto cycle" setting easily programmable.
- Digital read-out and "Autocycle" setting
- Pump usage information, hour and cycle counts
- Low-voltage warning and recording
- Self-test and diagnostic capabilities
- Information can be displayed in English, French, German, Italian, Spanish and Portuguese
- Pressure transducer is more accurate and durable than analog gauges
- Easy-viewing variable rate display
- Display pressure in bar, MPa or psi.



◀ The ZE4T-Series torque wrench pumps are perfectly matched for this W2000X wrench.

# Electric Torque Wrench Pumps

ZE4T AND ZE5T-SERIES OIL FLOW VERSUS PRESSURE

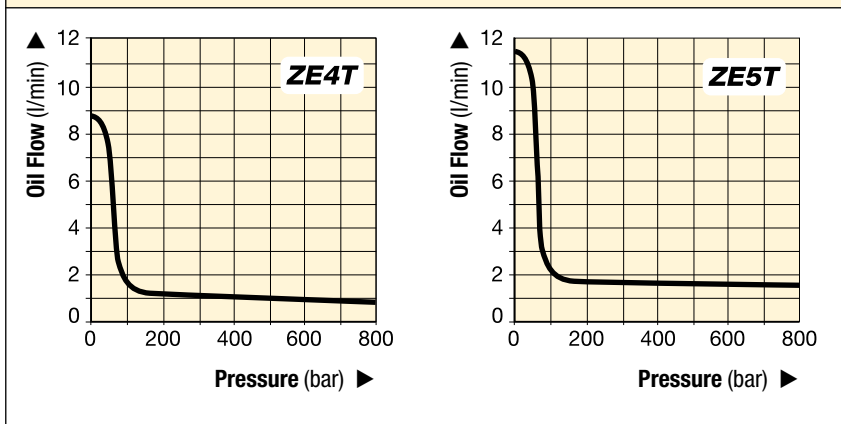

## ZE4T ZE5T Series



Reservoir Capacity:

**4 - 40 litres**

Flow at Rated Pressure:

**0,82 - 1,64 l/min**

Motor Size:

**1,1 - 2,2 kW**

Maximum Operating Pressure:

**700 bar**

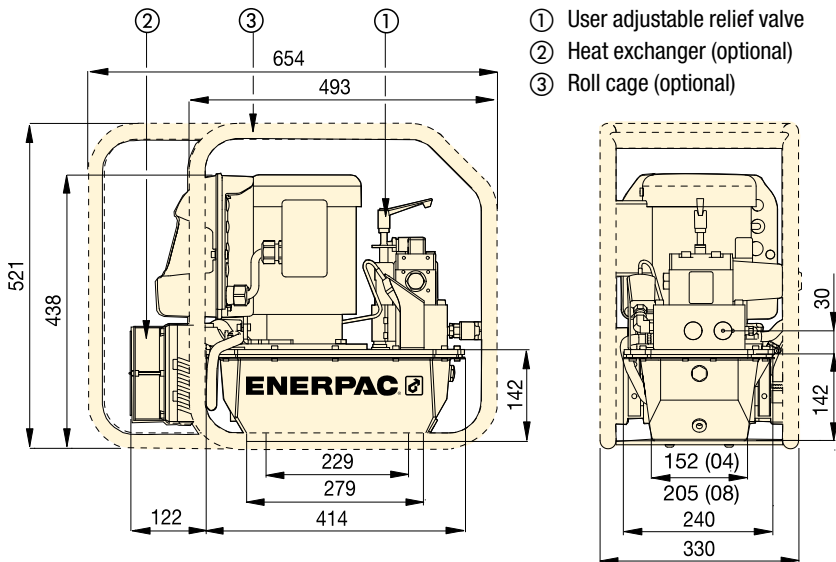

ZE4T and ZE5T-Series, 4 and 8 litres reservoirs

### ▼ COMMON TORQUE WRENCH PUMP MODELS

For Use With Torque Wrenches	Max. Operating Pressure (bar)	Model Number with Heat Exchanger and Roll Cage	Motor Electrical Specification (Volt - Ph - Hz)	Usable Oil Capacity <sup>1)</sup> (litres)	Weight (kg)
all S and W-Series	700	ZE4204TB-QHR	115 - 1 - 50/60	4,0	61
	700	ZE4204TE-QHR	230 - 1 - 50/60	4,0	61
	700	ZE4204TG-QHR	230 - 3 - 50/60	4,0	62
	700	ZE5204TW-QHR	400 - 3 - 50/60	4,0	62

<sup>1)</sup> Larger reservoirs (8, 10, 20 and 40 litres) are available. Contact Enerpac.

### ▼ PERFORMANCE CHART

Pump Series	Output Flow Rate at 50 Hz <sup>2)</sup> (l/min)				Motor Size (kW)	Relief Valve Adjustment Range (bar)	Sound Level (dBA)
	7 bar	50 bar	350 bar	700 bar			
ZE4T	8,8	8,1	0,9	0,8	1,1	70 - 700	75
ZE5T	11,8	11,2	1,7	1,6	2,2	70 - 700	75

<sup>2)</sup> Flow rate will be approximately 6/5 higher at 60 Hz.



### Torque Wrench Pump Selection Matrix

For optimum speed and performance see the torque wrench pump and hose selection matrix.

Page: **212**



### Torque Wrench Hoses

Use Enerpac twin safety hoses to connect your torque wrench to the pump.

For 700 bar	Model-Nr.
6 m long, 2 hoses	THQ-706T
12 m long, 2 hoses	THQ-712T



▼ ZA4204TX-QR



- Two-speed operation and high by-pass pressure reduces cycle time for improved productivity
- Glycerin filled pressure gauge with transparent overlays in Nm and Ft.lbs for Enerpac torque wrenches provide a quick torque reference
- Standard Regulator-Filter-Lubricator with removable bowls and auto drain
- Heat exchanger warms exhaust air to prevent freezing and cools the oil
- Ergonomic pendant allows remote operation up to 6 m.

#### Complete 700 bar Pump-Hose Set ZA4208TX-QRU105

- Fine air pressure adjustment for very accurate torque control
- Improved wrench performance at low pressure
- Standard with THQ706T twin hose.



# Z

Tough,  
Dependable  
Innovative  
**CLASS**



#### Torque Wrench Hoses

Use Enerpac twin safety hoses to connect your torque wrench to the pump.

For 700 bar	Model-Nr.
6 m long, 2 hoses	THQ-706T
12 m long, 2 hoses	THQ-712T



#### Gauge and Overlay Kit

Gauge Overlay Kits are available separately for use with ZA4T-Series pumps: **GT-4015-Q** includes gauge and overlays for all S- and W-Series torque wrenches.



#### Torque Wrench Pump Selection Matrix

For optimum speed and performance see the torque wrench pump and hose selection matrix.

Page: 212

◀ Most hydraulic torque wrenches can be powered by the Enerpac ZA4T-Series torque wrench pump.

# Air Driven Torque Wrench Pumps



## ZA4T-Series Pump Applications

The ZA4T-Series pump is best suited to power medium to large size torque wrenches.

Patent-pending Z-Class technology provides high by-pass pressures for increased productivity.

Its high power to weight ratio and compact design make it ideal for applications which require easy transport of the pump.

All ZA4T-Series pump models meet CE, CSA and TÜV safety requirements. For further application assistance contact your local Enerpac office.

## ATEX 95 Certified

The ZA4T-Series pumps are tested and certified according to the Equipment Directive 94 / 9 / EC "ATEX Directive".

The explosion protection is for equipment group II, equipment category 2 (hazardous area zone 1), in gas and/or dust atmospheres. The ZA4T-Series pumps are marked with: **Ex II 2 GD ck T4**.



## ZA4T Series



Reservoir Capacity:

**4,0 - 8,0 litres**

Flow at Rated Pressure:

**0,8 - 1,0 l/min**

Air Consumption:

**600 - 2840 l/min**

Maximum Operating Pressure:

**700 bar**

## OIL FLOW VERSUS PRESSURE

6,9 bar dynamic air pressure at 2840 l/min

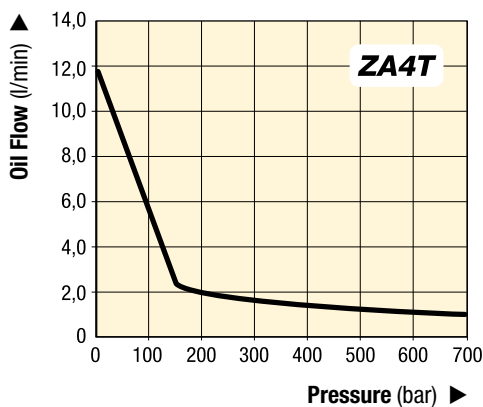

## Accessory Options

Available by placing the following additional suffix at the end of the model number:

- K** = Skid bar
- M** = 4-wrench manifold
- R** = Roll cage.

Page: 224

▼ ZA4208TX-QRU105 for improved wrench performance and torque control at low pressure.



## COMMON PUMP MODELS

For Use With Torque Wrenches	Maximum Operating Pressure (bar)	Model Number	Usable Oil Capacity (litres)	Weight (kg)
all S and W-Series	700	ZA4208TX-QRU105 *	6,6	58
	700	ZA4204TX-Q	2,7	42
	700	ZA4208TX-Q	6,6	47
	700	ZA4204TX-QR	2,7	46
	700	ZA4208TX-QR	6,6	51

\* Standard with THQ706T hose and fine air pressure adjustment for very accurate torque control.



### Skid Bar

- Provides greater pump stability on soft or uneven surfaces
- Provides easy two-handed lift.



### 4-Wrench Manifold

- For simultaneous operation of multiple torque wrenches
- Can be factory installed or ordered separately.



### Roll Cage

- Protects pump
- Provides greater pump stability.

Accessory Kit * Model Nr.	Can be used on ZA4T-Series torque wrench pumps
<b>SBZ-4</b>	Reservoir 04 and 08

\* Add suffix **K** for factory installation.  
Weight skid bar 2,2 kg.  
**Ordering Example: ZA4208TX-QK**

Accessory Kit * Model Nr.	Can be used on ZA4T-Series torque wrench pumps
<b>ZTM-Q</b>	for 700 bar torque wrenches

\* Add suffix **M** for factory installation.  
Weight manifold 4,5 kg.  
**Ordering Example: ZA4208TX-QM**

Accessory Kit * Model Nr.	Can be used on ZA4T-Series torque wrench pumps
<b>ZRC-04</b>	Reservoir 04 and 08

\* Add suffix **R** for factory installation.  
Roll cage weight 3,4 kg.  
**Ordering Example: ZA4208TX-QR**



### 700 bar Spin-on Couplers

- Mounted on:
  - Torque wrench pumps with suffix "Q"
  - S and W-Series wrenches
  - THQ-Series hoses
  - 4-Wrench manifold ZTM-Q.



### Torque Wrench Hoses

Use Enerpac twin safety hoses to connect your torque wrench to the pump.

For 700 bar	Model-Nr.
6 m long, 2 hoses	<b>THQ-706T</b>
12 m long, 2 hoses	<b>THQ-712T</b>



### Torque Wrench Couplers

For Enerpac torque wrench couplers see our "System Components" section in this catalogue.

# Ordering Matrix and Specifications

▼ This is how a ZA4T-Series pump model number is built up:

<b>Z</b>	<b>A</b>	<b>4</b>	<b>2</b>	<b>08</b>	<b>T</b>	<b>X</b>	<b>-</b>	<b>Q</b>	<b>M</b>	<b>R</b>
1 Product Type	2 Motor Type	3 Flow Group	4 Valve Type	5 Reservoir Size	6 Valve Operation	7 Voltage		8 Must be E or Q	8 Options	8 Options

### 1 Product Type

Z = Pump series

### 2 Motor Type

A = Air motor

### 3 Flow Group

4 = 1,0 l/min @ 700 bar

### 4 Valve Type

2 = Torque Wrench Valve

### 5 Reservoir Size

(useable oil capacity)

04 = 2,7 litres

08 = 6,6 litres

### 6 Valve Operation

T = Air operated valve with pendant

### 7 Voltage

X = Not applicable

### 8 Options

Q = **700 bar couplers** for use with S and W-Series or other wrenches

K = Skid bar

M = 4-wrench manifold

R = Roll cage

## ZA4T Series



Reservoir Capacity:

**4 - 8 litres**

Flow at Rated Pressure:

**0,8 - 1,0 l/min**

Air Consumption:

**600 - 2840 l/min**

Maximum Operating Pressure:

**700 bar**



### How to order your ZA4T-Series torque wrench pump

**Model No. ZA4208TX-QMR:** 700 bar pump for use with Enerpac S- and W-Series and other 700 bar torque wrenches, 8 litres reservoir, 4-wrench manifold, and roll cage.

Refer to the torque wrench pump selection matrix for optimum wrench, pump and hose combinations.

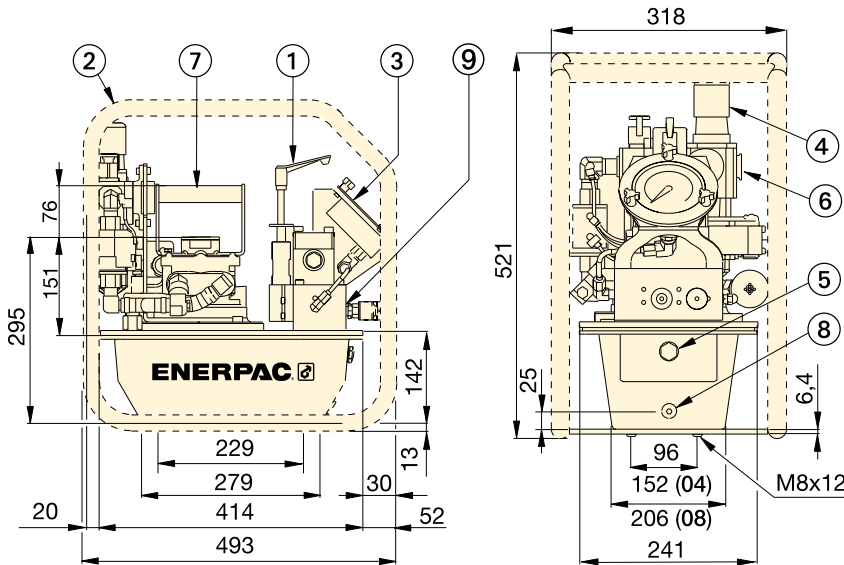

- ① User adjustable relief valve
- ② Roll Cage (optional)
- ③ Gauge with overlays
- ④ Filter/lubricator/regulator
- ⑤ Oil level sight gauge

- ⑥ Air input 1/2" NPTF
- ⑦ Standard handle
- ⑧ Oil drain
- ⑨ 1/4"-18 NPTF Oil outlet

ZA4T-Series Performance								
Output Flow Rate (l/min)				Dynamic Air Pressure Range (bar)	Air Consumption (l/min)	Sound Level (dBA)	Relief Valve Adjustment Range (bar)	
7 bar	50 bar	350 bar	700 bar					
11,5	8,8	1,2	1,0	4,0 - 6,9	600 - 2840	85-90	124-700	
5,4 *	4,8 *	1,1 *	0,8 *	7,0 *				

\* ZA4208TX-QRU105 only.

▼ Most hydraulic torque wrenches can be powered by the Enerpac ZA4T-Series torque wrench pump.



▼ Shown: GT-Series Bolt Tensioners



## Accurate & Reliable Extreme Performance Bolt Tensioner



### Tensioning Pumps, Hoses and Couplers

High pressure pumps, hoses and fittings matched for use with the Enerpac GT-Series Bolt Tensioning system.

Page: 229



### Minimum Stud Protrusion

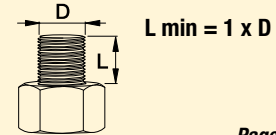

Page: 280

- Six load cells from M16 to M95 or from 5/8" to 3 3/4"
- Twin ports for quick connection of multiple tools
- Only one size of bridge per size of load cell
- Detachable and rotational bridge simplifies tool positioning
- Full bridge window
- Piston stroke indicator
- Black surface treatment protects against corrosion
- Anti-slip grip for more secure handling
- Universal and multi-use tool.

▼ Leak free connections on critical joints with GT-Series hydraulic tensioners applying accurate bolt loads when assembling multiple flanges on a gas treatment facility.

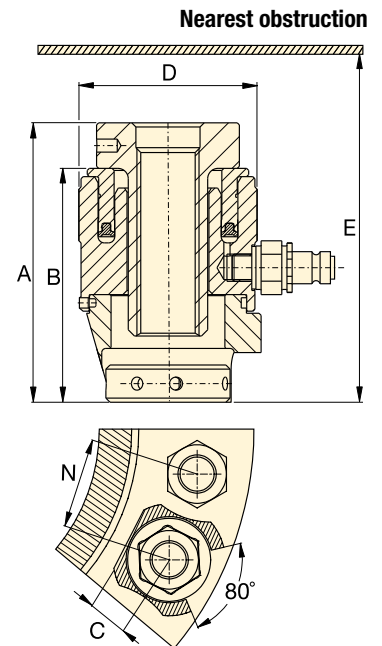

Bolt Range		Load Cell and Bridge Reference	Technical Data			Dimensions (mm)				 (kg)
(mm)	(inch)		Cylinder Effective Area (mm <sup>2</sup> )	Load Capacity (kN)	Stroke (mm)	A	B	C	D	
M16-M30	5/8"-1"	<b>GT1-LCB</b>	1495,4	224,3	10	135	113	27	86	3,0
M30-M39	1 1/8"-1 1/2"	<b>GT2-LCB</b>	2677,2	401,5	10	136	111	35	107	4,1
M39-M52	1 1/2"-2"	<b>GT3-LCB</b>	5127,1	768,9	10	160	126	46	138	7,0
M52-M68	2"-2 1/2"	<b>GT4-LCB</b>	9782,1	1466,9	10	180	141	62	174	12,2
M68-M80	2 1/2"-3 1/4"	<b>GT5-LCB</b>	15079,7	2261,4	10	202	157	78	210	18,7
M80-M95	3 1/4"-3 3/4"	<b>GT6-LCB</b>	18972,1	2845,1	10	219	173	82	240	27,8

# Hydraulic Bolt Tensioners

Load Cell and Bridge Reference	Thread Size	Adaptor Kit Model Number	Pitch Between Bolts N (mm)	Minimum Height E (mm)	 (kg)
GT1-LCB (224 kN)	M16 x 2	GT1PM-NRS01620	55	169	1,6
	M18 x 2,5	GT1PM-NRS01825	56	165	1,5
	M20 x 2,5	GT1PM-NRS02025	57	165	1,4
	M24 x 3	GT1PM-NRS02430	59	164	1,3
	M27 x 3	GT1PM-NRS02730	62	167	1,2
	M30 x 3,5	GT1PM-NRS03035	65	170	1,0
	5/8"-11UN	GT1P-NRS0625U11	55	169	1,6
	3/4"-10UN	GT1P-NRS0750U10	56	165	1,4
	7/8"-9UN	GT1P-NRS0875U09	59	164	1,3
	1"-8UN	GT1P-NRS1000U08	62	167	1,2
1 1/8"-8UN	GT1P-NRS1125U08	65	170	1,0	
GT2-LCB (401 kN)	M30 x 3,5	GT2PM-NRS03035	71	173	2,6
	M33 x 3,5	GT2PM-NRS03335	74	174	2,4
	M36 x 4	GT2PM-NRS03640	77	177	2,2
	M39 x 4	GT2PM-NRS03940	80	180	1,9
	1 1/8"-8UN	GT2P-NRS1125U08	71	173	2,6
	1 1/4"-8UN	GT2P-NRS1250U08	74	174	2,4
	1 3/8"-8UN	GT2P-NRS1375U08	77	177	2,2
1 1/2"-8UN	GT2P-NRS1500U08	80	180	2,0	
GT3-LCB (769 kN)	M39 x 4	GT3PM-NRS03940	92	212	5,7
	M42 x 4,5	GT3PM-NRS04245	96	215	5,4
	M45 x 4,5	GT3PM-NRS04545	99	218	5,0
	M48 x 5	GT3PM-NRS04850	105	216	4,7
	M52 x 5	GT3PM-NRS05250	108	220	4,2
	1 1/2"-8UN	GT3P-NRS1500U08	92	212	5,7
	1 5/8"-8UN	GT3P-NRS1625U08	96	215	5,3
	1 3/4"-8UN	GT3P-NRS1750U08	99	218	5,0
	1 7/8"-8UN	GT3P-NRS1875U08	105	216	4,6
2"-8UN	GT3P-NRS2000U08	108	220	4,2	
GT4-LCB (1467 kN)	M52 x 5	GT4PM-NRS05250	118	240	10,7
	M56 x 5,5	GT4PM-NRS05655	121	244	10,1
	M60 x 5,5	GT4PM-NRS06055	124	248	9,4
	M64 x 6	GT4PM-NRS06460	127	252	8,8
	M68 x 6	GT4PM-NRS06860	130	256	8,1
	2"-8UN	GT4P-NRS2000U08	118	240	10,7
	2 1/4"-8UN	GT4P-NRS2250U08	121	244	9,7
2 1/2"-8UN	GT4P-NRS2500U08	127	252	8,5	
GT5-LCB (2261 kN)	M68 x 6	GT5PM-NRS06860	145	278	17,3
	M72 x 6	GT5PM-NRS07260	149	282	16,4
	M76 x 6	GT5PM-NRS07660	152	286	15,5
	M80 x 6	GT5PM-NRS08060	162	293	14,6
	2 1/2"-8UN	GT5P-NRS2500U08	144	274	17,8
	2 3/4"-8UN	GT5P-NRS2750U08	149	282	16,3
	3"-8UN	GT5P-NRS3000U08	152	286	14,8
3 1/4"-8UN	GT5P-NRS3250U08	162	293	13,1	
GT6-LCB (2845 kN)	M80 x 6	GT6PM-NRS08060	169	312	22,3
	M85 x 6	GT6PM-NRS08560	169	312	21,0
	M90 x 6	GT6PM-NRS09060	178	317	19,4
	M95 x 6	GT6PM-NRS09560	181	322	18,0
	3 1/4"-8UN	GT6P-NRS3250U08	169	312	20,7
	3 1/2"-8UN	GT6P-NRS3500U08	178	317	18,8
3 3/4"-8UN	GT6P-NRS3750U08	181	322	16,8	

## GT Series



Bolt Range:

**M16 - M95, 5/8" - 3 3/4"**

Maximum Load:

**2845 kN**

Maximum Operating Pressure:

**1500 bar**



### How to Order

To provide maximum flexibility Load Cell and Bridges are ordered separately from Adaptor Kits.

Example, to order a complete tensioner for a M36 x 4 threaded bolt order:

1 x Load Cell and Bridge: **GT2-LCB**

1 x Adaptor Kit: **GT2PM-NRS03640**



### Bolting Integrity Software

A comprehensive on-line software solution for Bolted Joint integrity at [www.enerpac.com](http://www.enerpac.com)

Integral databases hold data for:

- BS1560, MSS SP44, API 6A and 17D flanged joints
- Common gasket materials and configurations
- Comprehensive range of bolt materials
- Comprehensive range of lubricants
- Enerpac's Controlled Bolting Equipment including: Torque Multipliers, Hydraulic Wrenches and Bolt Tensioning tools.

Custom Joint information can also be entered.

The software offers Tool selection, Bolt Load calculations and Tool pressure settings, as well as, a combined Application data sheet and Joint completion report.

▼ ZUTP-1500E



## ZUTP Series

Reservoir Capacity:  
**4,0 litres**

Flow at Rated Pressure:  
**0,13 l/min**

Maximum Operating Pressure:  
**1500 bar**

- Two-stage pump design provides high flow at low pressure for fast system fills and controlled flow at high pressure for safe and accurate operation
- 6 m pendant cord enables motor control from a distance
- Angled 153 mm pressure gauge, with polycarbonate cover, built into a protective metal shroud for improved visibility and protection
- Safety relief valve limits output pressure
- Compact, lightweight and rugged aluminium frame for increased durability and ease of handling.

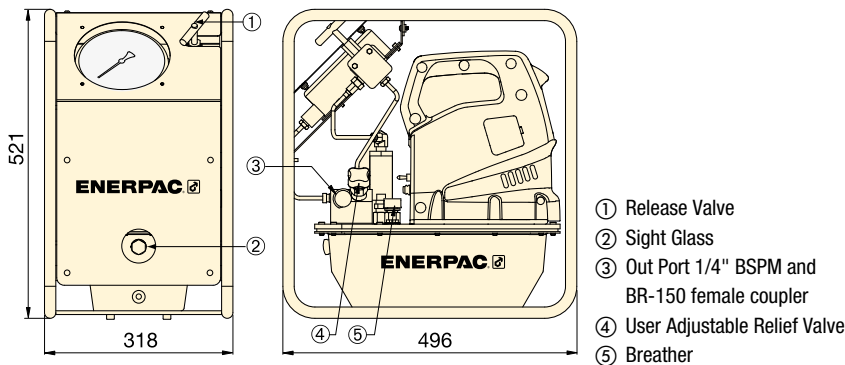

### Applications

The Enerpac ZUTP-Series electric pump is ideally suited for use with hydraulic bolt tensioning tools and hydraulic nuts.

Page: 226



### 1500 bar hoses and couplers

This pump operates at ultra-high pressure, use only the specified fittings and hoses designed for these pressures.

Page: 229



### Bolting Theory

See our 'Yellow Pages' for information on torque tightening and tensioning.

Page: 265

### 1500 bar HIGH PRESSURE PUMP

Pump Type	Useable Oil Capacity (litres)	Model Number <sup>1)</sup>	Pressure Rating (bar)	Output Flow Rate at 0 bar (l/min)	Output Flow Rate at 1500 bar (l/min)	Motor Electrical Specification	Motor Size (kW)	Sound Level (dBA)	 (kg)
Two speed	4,0	<b>ZUTP-1500 B</b>	1500	2,90	0,13	115 VAC, 1-ph	1,25	89	29,5
	4,0	<b>ZUTP-1500 E <sup>2)</sup></b>	1500	2,90	0,13	230 VAC, 1-ph <sup>2)</sup>	1,25	89	29,5
	4,0	<b>ZUTP-1500 I <sup>3)</sup></b>	1500	2,90	0,13	230 VAC, 1-ph <sup>3)</sup>	1,25	89	29,5

<sup>1)</sup> All models meet CE safety requirements and all TÜV requirements.

<sup>2)</sup> European plug and CE EMC directive compliant.

<sup>3)</sup> With NEMA 6-15 plug.

# High Pressure Hand Pump and Accessories

▼ HPT-1500



- Lightweight and portable high-pressure hand pump
- Two-speed operation displaces a larger volume of oil per stroke, reducing cycle times for many testing applications
- Includes a pressure gauge and coupler for direct connection to Enerpac GT-Series Bolt Tensioners
- Integrated relief valve set at 1500 bar.

## HPT, HT, B Series

Reservoir Capacity:

**2,5 litres**

Flow at Rated Pressure:

**0,61 cm<sup>3</sup>/stroke**

Maximum Operating Pressure:

**1500 bar**



### Ultra-high pressure

This pump operates at ultra-high pressure, use only the specified fittings and hoses designed for these pressures.



### Applications

The hand pump is ideally suited for use with hydraulic bolt tensioning tools and hydraulic nuts.

Page: **226**

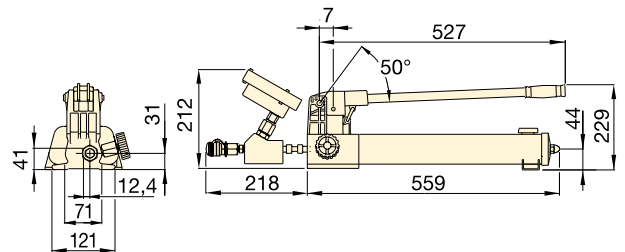

### 1500 bar ULTRA-HIGH PRESSURE PUMP

Pump Type	Useable Oil Capacity (litres)	Model Number	Pressure Rating (bar)		Oil Displacement per Stroke (cm <sup>3</sup> )		High Pressure Oil Port with female coupler	Weight (kg)
			1st stage	2nd stage	1st stage	2nd stage		
Two Speed	2,54	<b>HPT-1500</b>	14	1500	16,22	0,61	1/4" BSPM + BR-150	9,0

### 1500 bar HOSES

Model Number		Hose End 1	Hose End 2	Length (m)
HT-1503		1/4" BSPM 120° Cone	1/4" BSPM 120° Cone	1,0
HT-1510		1/4" BSPM 120° Cone	1/4" BSPM 120° Cone	3,0
HT-1503HR*		<b>BH-150</b>	<b>BR-150</b>	1,0
HT-1510HR*		<b>BH-150</b>	<b>BR-150</b>	3,0

\* Includes dust caps.

### 1500 bar COUPLERS

Description		Complete Set	Female Half	Male Half
Quick Disconnect Coupler *		<b>B-150</b>	<b>BR-150</b>	<b>BH-150</b>
Quick Disconnect Coupler and Adaptor Kit *		<b>BW-150AW</b>	-	-
Quick Disconnect Blanking Coupler Set *		<b>B-150B</b>	-	-

\* Includes dust caps.



# ATP-Series, Ultra-High Pressure Air Pump

▼ ATP-1500



- General purpose, high pressure air driven two speed pump unit for products requiring up to 1500 bar hydraulic pressure
- Compact, lightweight, rugged steel frame for protection and easy handling
- Prelubricated pump element, does not require an airline lubricator
- Easily adjustable output pressure control
- Integrated and protected easy to read glycerin filled gauge
- Safety relief valve limits output pressure.

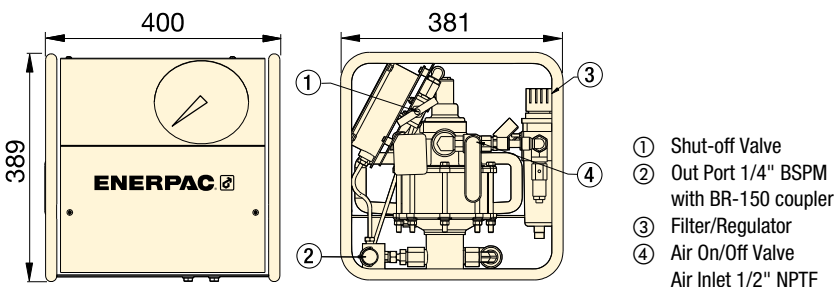

## ATP Series

Reservoir Capacity:  
**3,8 litres**

Flow at Rated Pressure:  
**0,07 l/min**

Maximum Operating Pressure:  
**1500 bar**



This pump operates at ultra-high pressure, use only the specified fittings and hoses designed for these pressures.

Page: 229



### Applications

The ATP-pump is ideally suited for use with GT-Series hydraulic bolt tensioning tools and hydraulic nuts. See our Bolting Tools

catalogue or [enerpac.com](http://enerpac.com)

Page: 226



### ATEX Certified

The ATP-Pump is tested and certified according ATEX.

 II 2 GD ck T4

Page: 265

### OIL FLOW VERSUS PRESSURE

Flow (l/min) at 6,2 bar air input

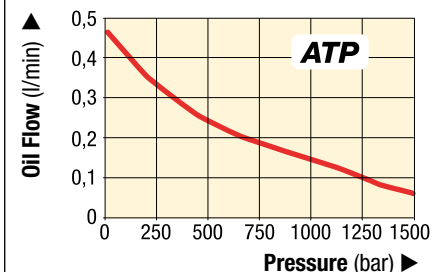

### 1500 bar HIGH PRESSURE AIR PUMP

Pump Type	Useable Oil Capacity (litres)	Pressure Rating (bar)	Model Number	Output Flow Rate at 0 bar (l/min)	Output Flow Rate at 1500 bar (l/min)	Air Pressure Range (bar)	Air Consumption (l/min)	Sound Level (dBA)	 (kg)
Two-speed	3,8	1500	<b>ATP-1500</b>	0,43	0,07	5,5 - 6,2	594	70	32

# NC-Series, Single-Acting Hydraulic Nut Splitters

▼ Shown from left to right: NC-3241, NC-1319, NC-1924



## NC, STN Series

Hexagon Nut Range:  
**10 - 75 mm**

Bolt Range:  
**M6 - M48**

Maximum Operating Pressure:  
**700 bar**

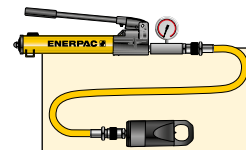

**Tool-Pump Sets**  
Hydraulic Nut Splitters are available as sets (pump, tool, gauge, gauge adaptor, couplers and hose) for your ordering convenience.

Nut Splitter Model Nr.	Hand Pump Model Nr.	Set Model Number
NC-1924	P-392	STN-1924H
NC-2432	P-392	STN-2432H
NC-3241	P-392	STN-3241H

- Compact and ergonomic design, easy to use
- Unique angled head design
- Two blade design (NC-D models) for time saving operation – nuts are split from two sides in one action
- Single-acting, spring return cylinder
- Heavy duty chisels can be reground
- Nut Splitters include spare chisel, spare set screw and wrench used to secure the chisel. A CR-400 coupler is standard.

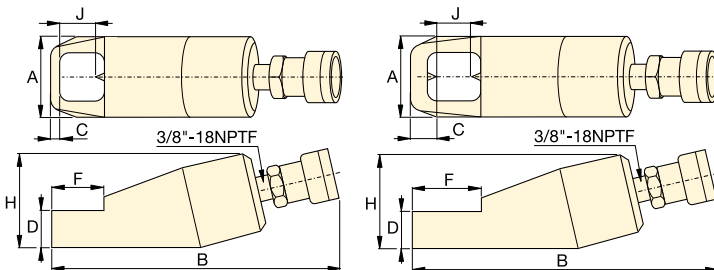

Single Blade Models (NC)

Double Blade Models (NC-D)

For Nut Splitter Model Nr.	Replacement Chisel Model Numbers	
	Moving	Static
NC-1319	NCB-1319	-
NC-1924	NCB-1924	-
NC-2432	NCB-2432	-
NC-3241	NCB-3241	-
NC-4150	NCB-4150	-
NC-5060	NCB-5060	-
NC-6075	NCB-6075	-
NC-2432D	NCB-2432	NCB-2432D
NC-3241D	NCB-3241	NCB-3241D

	Bolt Range (mm)	Hexagon Nut Range (mm)	Capacity ton (kN)	Oil Capacity (cm <sup>3</sup> )	Model Number	Dimensions (mm)						Weight (kg)	
						A	B	C	D	F	H		J
	M6 - M12	10 - 19	5 (49)	15	NC-1319	40	170	7	19	28	48	21	1,2
	M12 - M16	19 - 24	10 (98)	20	NC-1924 *	54	191	10	26	40	62	25	2,0
	M16 - M22	24 - 32	15 (147)	60	NC-2432 *	64	222	13	29	51	72	33	3,0
	M22 - M27	32 - 41	20 (196)	80	NC-3241 *	75	244	17	36	66	88	43	4,4
	M27 - M33	41 - 50	35 (343)	155	NC-4150	94	288	21	45	74	105	54	8,2
	M33 - M39	50 - 60	50 (490)	240	NC-5060	106	318	23	54	90	128	60	11,8
	M16 - M22	24 - 32	15 (147)	60	NC-2432D	64	275	25	31	65	78	33	5,4
	M22 - M27	32 - 41	20 (196)	80	NC-3241D	77	305	31	37	80	90	43	7,2

Ordering Notes: Maximum allowable hardness to split is HRc-44. Not to be used on square nuts or stainless steel.

\* Available as Tool-Pump Set, see note on this page.

▼ Shown: NS-Series Hydraulic Nut Splitters



- Specially designed to suit standard ANSI B16.5 / BS1560 flanges
- Single-acting (spring return) cylinder
- Tri-blade technology provides three cutting surfaces on a single blade
- Interchangeable heads provide maximum nut range flexibility
- Preset scale allows controlled blade extension, which avoids damage to bolt threads
- Grip tape and handle included for more secure manoeuvrability
- Nickel-plated cylinder body for excellent corrosion protection and improved durability in harsh environments
- Internal pressure relief valve for overload protection
- CR-400 coupler and dustcap included on all models.

▼ Heavily corroded and weathered nuts are quickly split and removed using a NS-Series Nut Splitter.



Nut splitter set for joint separation during inspection, maintenance and decommissioning operations. ▶

## Power and Precision High Performance Nut Splitter



### Blade Cutting Depth Scale

Adjustable cutting depth scale for controlled blade extension, which avoids damage to bolt threads. The scale indicates the

bolt range in metric and imperial values on each cutting head.



### NC-Series, Hydraulic Nut Cutters

The NC-Series models are available featuring an angle-head design for 10 - 75 mm hexagon nuts.

Page: 231



### Joint Separation Tools

FS and FSH-Series parallel wedge spreaders provide quick and easy joint separation using hydraulic or mechanical force.

Page: 234



### Flange Alignment Tools

The ATM-Series provide safe and high-precision flange alignment tools that fit most commonly used ANSI, API, BS and DIN flanges.

Page: 236



# Hydraulic Nut Splitters



## Nut Splitter Sets

To provide maximum flexibility, NS-Series Nut Splitters can also be ordered in sets (NS-xxxSy). Select Nut Splitter size and pump style from the chart below. To order additional Cutting Heads (NSH-xxxxxx), Cylinders (NSC-xxx) or Replacement Blades (NSB-xxx), see Selection Chart below.

## SET SELECTION:

- 1 Select your Nut Splitter
- 2 Select your pump type

## NS Series



Capacity:

**917 - 1711 kN**

Hexagon Nut Size:

**70 - 130 mm**

Bolt Range:

**M45 - M90**

Maximum Operating Pressure:

**700 bar**

## ▼ TOOL-PUMP SET SELECTION CHART

Nut Splitter Model Nr.	Tool-Pump Set Model Nr.	Pump Selection				Accessories Included			
		Hand Pump Model Nr.	Air Pump Model Nr.	Cordless Pump (230V) Model Nr.	Electric Pump (230V) Model Nr.	Pressure Gauge Model Nr.	Gauge Adaptor Model Nr.	Hydraulic Hose Model Nr.	Storage Case Model Nr.
NS-70105	NS-70105SH	P-392	-	-	-	GP-10S	GA-2	HC-7206	CM-4
	NS-70105SA	-	XA-11G <sup>2)</sup>	-	-	<sup>2)</sup>	-	HC-7206	CM-4
	NS-70105SCE <sup>1)</sup>	-	-	XC-1202ME	-	GA45GC <sup>3)</sup>		HC-7206	CM-4
	NS-70105SEE <sup>1)</sup>	-	-	-	PUD-1100E	GP-10S	GA-2	HC-7206	CM-7
NS-110130	NS-110130SH	P-802	-	-	-	GP-10S	GA-2	HC-7206	CM-4
	NS-110130SA	-	XA-11G <sup>2)</sup>	-	-	<sup>2)</sup>	-	HC-7206	CM-4
	NS-110130SCE <sup>1)</sup>	-	-	XC-1202ME	-	GA45GC <sup>3)</sup>		HC-7206	CM-4
	NS-110130SEE <sup>1)</sup>	-	-	-	PUD-1100E	GP-10S	GA-2	HC-7206	CM-7

<sup>1)</sup> For set with 115 Volt pump application replace last suffix "E" with "B" in model number.

Example : **NS-70105SCB** (set with XC-cordless pump, 115V);

Example: **NS-110130SEB** (set with PU-Series electric pump, 115 V)

<sup>2)</sup> XA-11G air pump features an integrated pressure gauge.

<sup>3)</sup> See page 126 for GA45GC details.

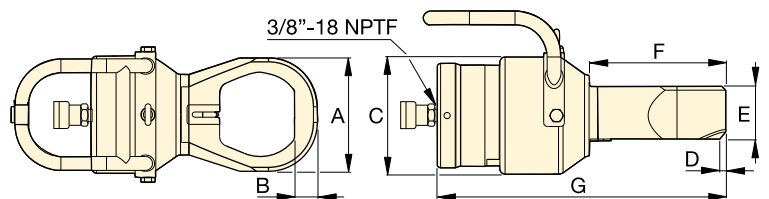

## ▼ NUT SPLITTER SPECIFICATIONS

Bolt Range	Hexagon Nut Range <sup>1)</sup>	Capacity	Oil Capacity	Model Number <sup>2)</sup>	Dimensions (mm)							Cylinder <sup>3)</sup>	Cutting Head <sup>3)</sup>	Replacement Blade	
					A	B	C	D	E	F	G				
(mm)	(mm)	ton (kN)	(cm <sup>3</sup> )									(kg)			
<b>M45 - M52</b>	70 - 80	<b>103</b> (917)	377	<b>NS-7080</b>	132	28	180	8,0	81	186	412	37,0	NSC-70	NSH-7080	NSB-70
<b>M45 - M56</b>	70 - 85	<b>103</b> (917)	377	<b>NS-7085</b>	145	30	180	8,0	81	196	422	37,0	NSC-70	NSH-7085	NSB-70
<b>M45 - M64</b>	70 - 95	<b>103</b> (917)	377	<b>NS-7095</b>	160	32	180	8,0	81	201	432	38,5	NSC-70	NSH-7095	NSB-70
<b>M45 - M72</b>	70 - 105	<b>103</b> (917)	377	<b>NS-70105</b>	174	35	180	9,0	81	209	443	39,5	NSC-70	NSH-70105	NSB-70
<b>M76 - M80</b>	110 - 115	<b>193</b> (1711)	819	<b>NS-110115</b>	189	36	234	3,7	111	234	472	69,0	NSC-110	NSH-110115	NSB-110
<b>M76 - M90</b>	110 - 130	<b>193</b> (1711)	819	<b>NS-110130</b>	219	41	234	2,5	111	242	493	71,5	NSC-110	NSH-110130	NSB-110

<sup>1)</sup> Maximum allowable hardness to split is HRc-44. See page 277 for hexagon bolt and nut sizes and related thread diameters.

<sup>2)</sup> NS-Series Nut Splitters ship in two cases: One containing the NSC-Cylinder and one containing the NSH-Cutting Head. Assembly required.

<sup>3)</sup> Both, the NSH-head and the NSC-cylinder include a cutting blade.

# FS-Series, Hydraulic Flange Spreaders

▼ FS-56



- Lightweight, ergonomic design for ease of use
- Adjustable jaw widths from 70 mm to 216 mm for a wide range of applications
- Single-acting, spring return RC-Series DUO cylinder for fast trouble-free operation.

## FS, STF Series



Capacity:

**5 and 10 ton**

Spread:

**70 - 216 mm**

Maximum Operating Pressure:

**700 bar**

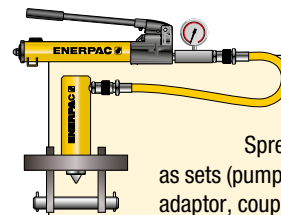

### Tool-Pump Sets

Both Flange Spreaders are available as sets (pump, tool, gauge, gauge adaptor, couplers and hose) for your ordering convenience.

Spreader Model Nr.	Pump Model Nr.	Set Model Number
FS-56	P-392	<b>STF-56H</b>
FS-109	P-392	<b>STF-109H</b>
FS-109	PATG-1102N	<b>STF-109A</b>



### Wedge Spreaders

Friction-free, smooth and parallel wedge movement with unique interlock wedge design. Eliminates flange damage and risk of spreading arm failure.

Page: 235

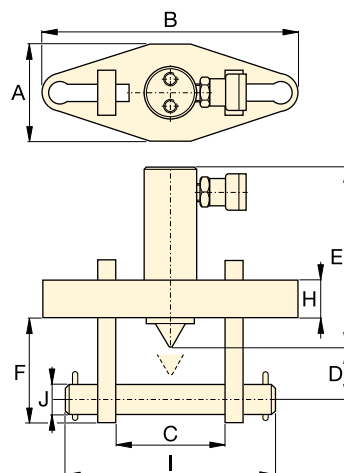
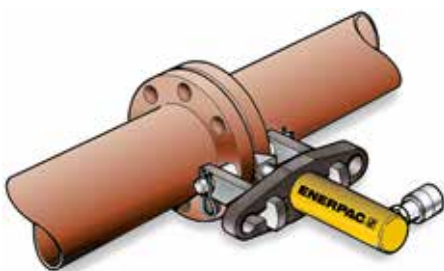

### Flange Spreader Matching Chart

ASA Rating (bar)	Pipe Size (mm)	
	FS-56	FS-109
10	127 - 508	558 - 1066
20	63 - 355	406 - 711
27	63 - 304	355 - 609
35	63 - 254	304 - 508
62	12 - 152	203 - 406
103	12 - 88	101 - 203
172	12 - 63	76 - 101

Maximum Flange Thickness (mm)	Stud Size (mm)	Standard Wedge (mm)	Capacity (ton)	Stroke (mm)	Oil Capacity (cm <sup>3</sup> )	Model Number	Dimensions (mm)										Weight (kg)
							A	B	C		D	E	F	H	I	J	
									Min.	Max.							
2 x 57	19 - 28	3 - 28	5	38	24,6	FS-56*	76	209	70	155	32	196	88	25	206	19	11,5
2 x 92	31 - 41	3 - 28	10	54	78,7	FS-109*	108	279	104	216	50	152	114	38	273	31	18,1

\* Available as Tool-Pump Set, see note on this page.

# Hydraulic and Mechanical Wedge Spreaders

▼ FSH-14 and FSM-8 with safety blocks SB-1



- **Integrated wedge concept:** Friction-free, smooth and parallel wedge movement eliminates flange damage and spreading arm failure
- **Unique interlocking wedge design** - no first step bending and risk of slipping out of joint
- **Requires very small access gap of only 6 mm**
- **Stepped spreader arm design** - each step can spread under full load
- **Few moving parts mean durability and low maintenance**
- **Safety block SB-1 and ratchet spanner SW-22 included with FSM-8 mechanical wedge spreader**
- **Safety block SB-1 and Enerpac RC-102 single-acting cylinder included with FSH-14 hydraulic wedge spreader.**

## FSH, FSM, STF Series

Tip Clearance / Maximum Spread <sup>1)</sup>:

**6 mm / 80 mm**

Maximum Spread Force:

**8 - 14 ton**

Maximum Operating Pressure:

**700 bar (FSH-14)**



### Stepped Blocks FSB-1

Use stepped blocks to increase wedge opening up to 80 mm. Fits both FSH-14 and FSM-8.



### AM-Series Control Manifolds

For simultaneously and even spreading of flange joints, 180° apart with FSH-14.

Page: 118

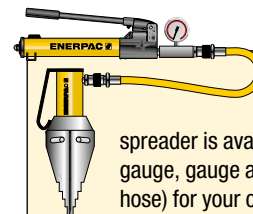

### Tool-Pump Sets

The hydraulic flange spreader is available as set (pump, tool, gauge, gauge adaptor, couplers and hose) for your ordering convenience.

Spreader Model Nr.	Handpump Model Nr.	Set Model Number
FSH-14	P-392	STF-14H

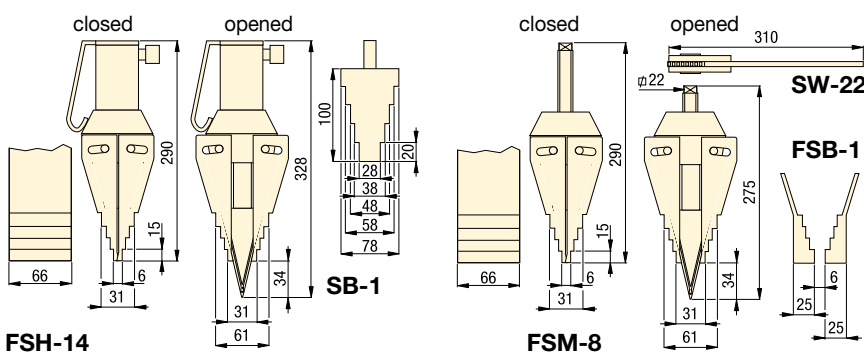

Maximum Spreading Force ton (kN)	Model Number	Tip Clearance (mm)	Maximum Spread <sup>1)</sup> (mm)	Spreader Type	Oil Capacity (cm <sup>3</sup> )	Weight (kg)
14 (125)	FSH-14*	6	80	Hydraulic	78	7,1
8 (72)	FSM-8	6	80	Mechanical	-	6,5

<sup>1)</sup> Using stepped blocks FSB-1

\* Available as pump-tool set, see note on this page.

▼ Flange maintenance and joint separation with FSH-14 Hydraulic Wedge Spreader.



# ATM-Series, Flange Alignment Tools

▼ From left to right: ATM-4, ATM-9, ATM-2 (ATM-9 shown without pump and hose)



- Enerpac ATM-Series tools rectify twist and rotational misalignment quickly, safely and without the need for an external power source
- Appropriate for use on most ANSI, API, BS and DIN flanges
- Reduces set-up time: no need for chains, pulleys or rigs
- Safety strap helps provide secure operation
- Can be installed and used in any position
- Stays stable in position under full load
- Portable, lightweight design enables easy transport and use, even in remote locations
- Each ATM-model contains a tool and kit box.

▼ The compact ATM-2 is actuated by simply hand turning the crank.



## The faster, simpler and safer way to align flanges.



### Adjustable Reach

The highly adjustable reach of the wing and drop leg on ATM-4 and ATM-9 allow precise alignment.



### Gauge and Adaptor

The ATM-9 includes P-142 hand pump and HC-7206C 1,8 m long hose. Enerpac recommend the use of the pressure gauge **GP-10S** and gauge adaptor **GA-4** for easy mounting of the gauge onto your system or use **GA45GC** Gauge Adaptor Assembly.

Page: **126**

▼ The ATM-9 is shown here with optional pressure gauge and gauge adaptor.





## Applications

Enerpac ATM-Series Tools help correct flange misalignment, and allow bolts to be placed into joints. This alignment takes place during pipework construction, or maintenance.

These tools provide pipe installers and maintenance personnel with some of the simplest, safest and most productive solutions available for flange alignment in the market today.

- ① Extendable wing provides usage on wide variety of flanges.
- ② Portable, light weight design enables easy transport and use.
- ③ Hand-adjustable base for easy positioning by a single operator.
- ④ Safety strap helps provide secure operation from a horizontal or vertical position.

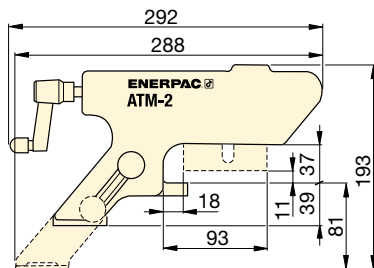
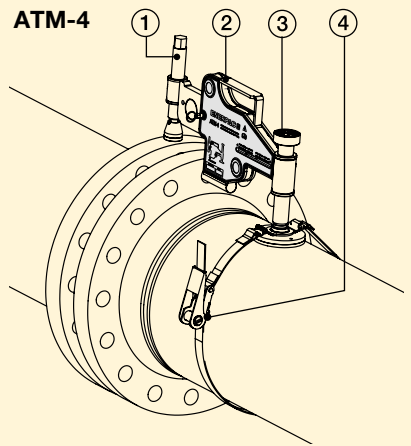

ATM-2

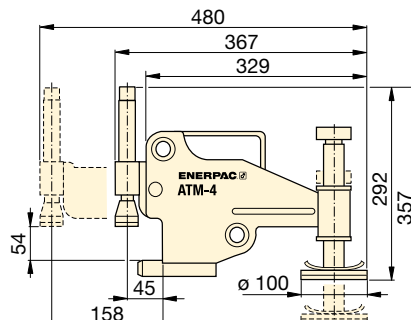

ATM-4

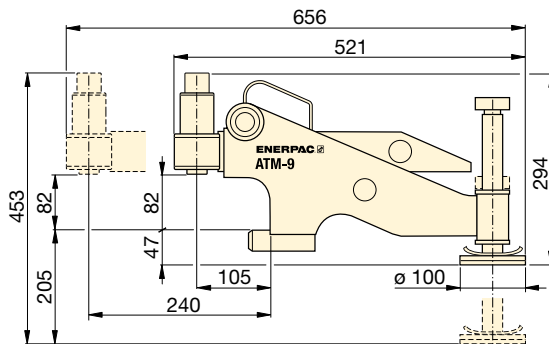

ATM-9

Maximum Lifting Force		Model Number	Minimum Bolt Size		Flange Wall Thickness		Weight (kg)
(ton)	(kN)		(mm)	(inch)	(mm)	(inch)	
1	10	ATM-2	16	.63	14 - 82	.55 - 3.29	1,6
4	40	ATM-4	24	.95	30 - 133	1.18 - 5.23	8,6
9	90	ATM-9 *	31,5	1.24	93 - 228	3.66 - 9.00	14,5

\* ATM-9 includes an Enerpac hand pump and hydraulic hose (gauge and adaptor sold separately). ATM-9 weight includes tool only.

## ATM Series



Minimum Bolt Size:

**16 - 31,5 mm**

Flange Wall Thickness:

**14 - 228 mm**

Maximum Lifting Force:

**1 - 9 ton (10 - 90 kN)**



### Cylinder-Pump Sets

Hydraulic cylinders, jacks and lifting wedges can also be used to assist in pipe line positioning and aligning.

Page: 52



### Pipe Flange Face Tool

The portable, hand powered tool FF-120 makes even the hardest to reach pipe flanges resurfaceable in a safe and convenient way.

Page: 238

▼ The ATM-Series – the faster, simpler and safer way to align flanges.





▼ FF-120



- **Makes refacing easy** – hand operated machine tool can be set up anywhere without the need for air, electric or hydraulic power
- **Lightweight and portable** (15 kg in storage box)
- **Adjustable cutting head** for reface of flat flange surfaces of pipes with flange outside diameter facing range 25,4 - 304,8 mm [1 - 12 inch]
- **Interchangeable collets** for ID mounting range 25,4 - 152,4 mm [1-6 inch] allow the user to work on many different flanges with minimal time between set-ups
- **Interchangeable lead screws** suitable for refacing damaged raised-face (RF), flat-face (FF) or lens-ring joint flanges
- **Tool body with expanding collets** centers itself providing real concentric operation.

▼ The Enerpac FF-120 used to face a pipe flange.



## Safe, efficient and accurate refacing of flat pipe flange surfaces



### Complete in Wheeled Carrying Case

The FF-120 comes as portable set (15 kg). Can be transported, easy set-up and operated by a single

technician. Set includes:

**FFL-kit** with locators, O-Rings and extensions;  
**FSS-kit** with feed screw and nut ½"-20 UN for surface roughness Ra 1,6 - 2,4 μ.

**FSF-kit** with feed screw and nut ½"-11 UNF for surface roughness Ra 3,2 - 6,3 μ.



### Joint Separation Tools

FS and FSH-Series parallel wedge spreaders provide quick and easy joint separation using hydraulic or mechanical force.

Page: 234



### Flange Alignment Tools

The ATM-Series provide safe and high-precision flange alignment tools that fit most commonly used ANSI, API, BS and DIN flanges.

Page: 236



### Controlled Tightening and Loosening

Use Enerpac Bolting Tools to seal the joint to the precise torque or tension required: torque

multipliers, torque wrenches and hydraulic bolt tensioners.

Page: 183

# QuickFace – Mechanical Pipe Flange Face Tool



## Mechanical Flange Face Tool

Portable, hand powered tool makes even the hardest to reach pipe flanges resurface-able in a safe and convenient way.

### Makes refacing easy

A simple and cost effective solution – the FF-120 turns a two man operation with heavy equipment, compressors and portable generators into a one man job.

The FF-120 has interchangeable lead screws that make it suitable for resurfacing damaged flat-faced, raised-face or lens-ring joint flanges to the high safety standards required. After selecting the correct lead screw for the operation, the tool body is inserted in the pipe end and centres itself with adjustable locators to provide real concentric operation.

The tool arm is then rotated by hand using a worm-gear mechanism to provide a perfect spiral “gramophone” finish. The tool can be adjusted with a calibrated slide to define cut depth and the correct finish.

### Surface finish & accuracy

A serrated finish with 30-55 grooves per inch and a resultant roughness of between Ra 3,2-12,5 µ (125-500 micro inches). The FF-120 has same precision and quality of finish as a lathe.

### Cost effective solution

Small and portable enough to be a permanent addition to your equipment range, Enerpac's FF-120 is the perfect solution to all of your small diameter facing problems.

## FF Series



Pipe Flange Cutting Diameter Range:

**ø 25-305 mm / 1-12"**

Internal Pipe Mounting Range:

**ø 25-152 mm / 1-6"**

Cutting Resultant Roughness:

**Ra 3,2 - 12,5 µ**



- 1 Hand-operated cold work tool – no need for external power and hot work permits.
- 2 Calibrated cross slide for accurate cutting control.
- 3 Adjustable cutting head for reface of flat flange surfaces of pipes with flange OD facing range ø 25,4-304,8 mm [1-12 inch].
- 4 Interchangeable lead screws enable selection of surface finish between Ra 3,2-12,5 µ.
- 5 Utilizes standard 3/8 inch or 10 mm tool steel.
- 6 Range of interchangeable collets allow the tool to accommodate ø 25,4 - 152,4 mm (1 - 6 inch) pipe ID.
- 7 Tool body with expanding collets centers in the bore ensuring concentric and accurate set-up.

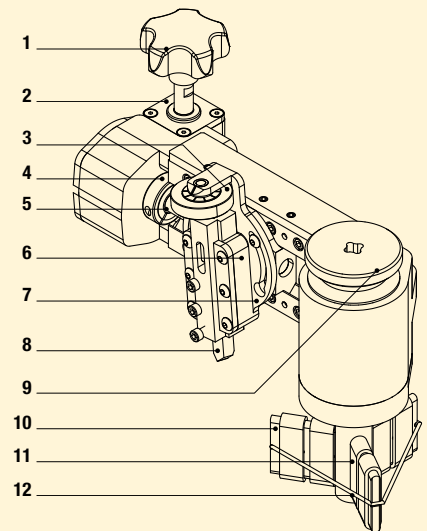

- |  |                        |
|--|------------------------|
| 1 Feed Knob  | 6 Tool Block           |
| 2 Gear Box   | 7 Swivel Slide         |
| 3 Cutting Depth Adjustment with indicator: 0,127 mm (.005 inch) per mark | 8 HSS 3/8" Tool Bits   |
| 4 Locking Collar   | 9 Mandrel Locking Knob |
| 5 Lead/Feed Screw  | 10 Locator Extensions  |
|  | 11 Adjustable Locators |
|  | 12 O-Ring              |

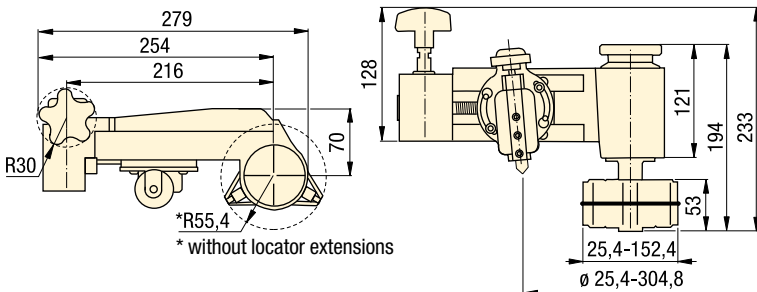

### SELECTION CHART

Pipe Flange Cutting Diameter Range		Internal Pipe Mounting Diameter Range		Cutting Resultant Roughness (Ra µ)	Model Number	Weight (kg)
(mm)	(inch)	(mm)	(inch)			
25,4 - 304,8	1,0 - 12,0	25,4 - 152,4	1,0 - 6,0	3,2 - 12,5	FF-120	6,8

▼ The Enerpac FF-120 QuickFace has same precision and quality of finish as a lathe.

