

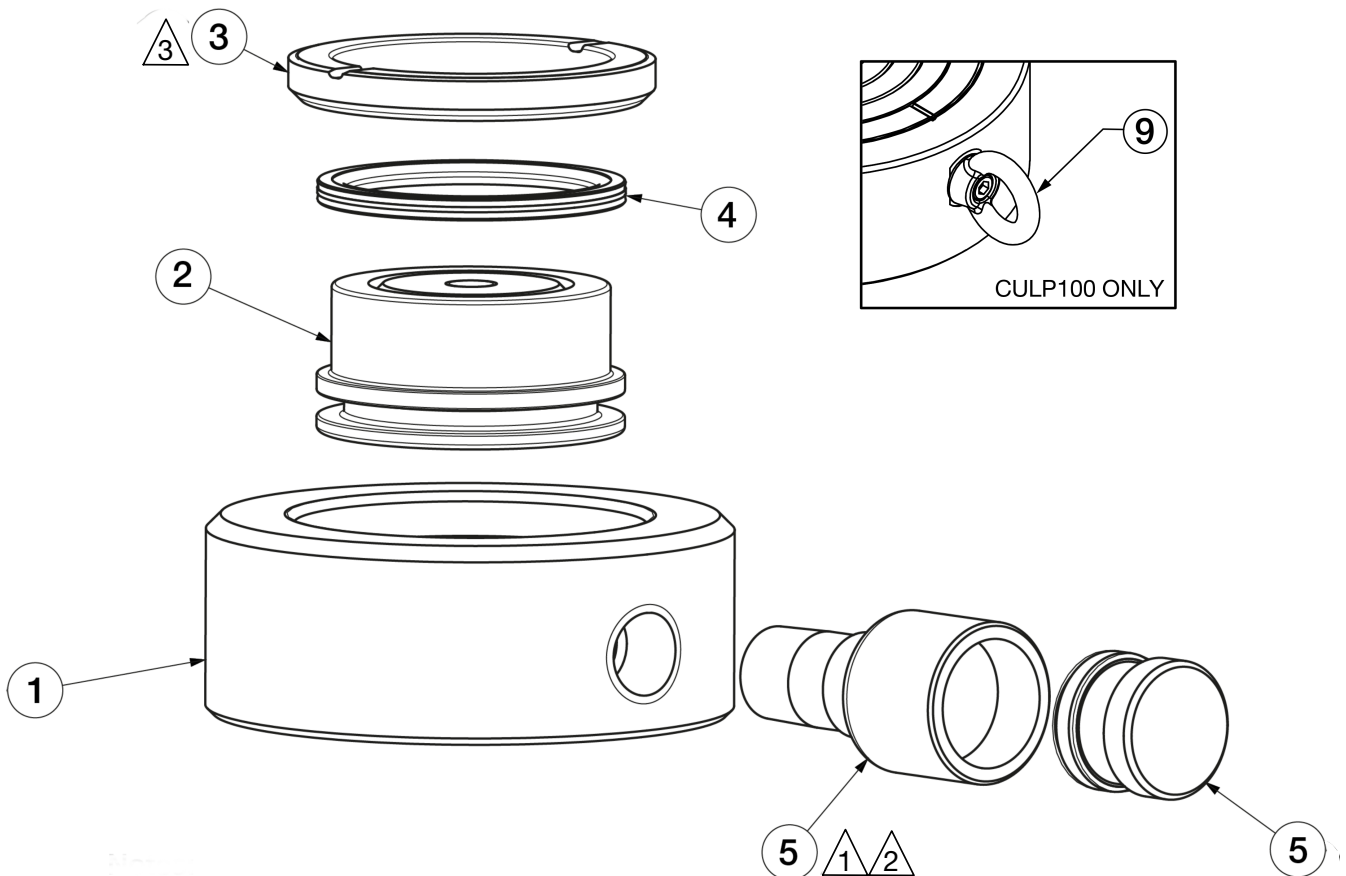



To Protect Your Warranty, Use Only ENERPAC Hydraulic Oil.

Enerpac recommends that all kit components be installed to insure optimum performance of the repaired unit.

Note: Apply Loctite 545 thread sealant to mating threads of items 1 and 5.



Notes:

-  Models CULP10 through CULP50: Torque to 23-28 ft-lbs [32-38 Nm].
-  Model CULP100 Only: Torque to 40-60 ft-lbs [55-81 Nm].
-  Secure with thread locker per EES 115-16-1.

Repair parts list for CULP-Series cylinders, models CULP10 through CULP100

Item	Description	Qty.	Part Number	Part Number	Part Number	Part Number	Part Number
			CULP10	CULP20	CULP30	CULP50	CULP100
1	CYLINDER BASE	1	B170042030-13	B170042030-14	B170042030-15	B170042030-1	B170042030-16
2	PLUNGER	1	B170042040-13	B170042040-14	B170042040-15	B170042040-1	B170042040-16
3	STOP RING	1	B170042044-13	B170042044-14	B170042044-15	B170042044-1	B170042044-16
4	PISTON SEAL	1	*	*	*	*	*
5	FEMALE COUPLER	1	AR630	AR630	AR630	AR630	CR400
6	WARNING DECAL (NOT SHOWN)	1	*CH272026	*CH272026	*CH272026	*CH272026	*CH272026
7	ENERPAC DECAL (NOT SHOWN)	1	*DB8172026	*DB8172026	*DB8172026	*DB8175026	*DB8175026
8	COUPLER O-RING (NOT SHOWN)	1	*	*	*	*	*
9	EYEBOLT, ROTATING	2	---	---	---	---	DB8099667
*INDICATES PARTS INCLUDED IN THE SERVICE KIT LISTED BELOW:							
SERVICE KIT		CULP10K	CULP20K	CULP30K	CULP50K	CULP100K	