



TD195

Rev. C

05/19

HYDRAULIC CABLE CUTTER

HCCS4750

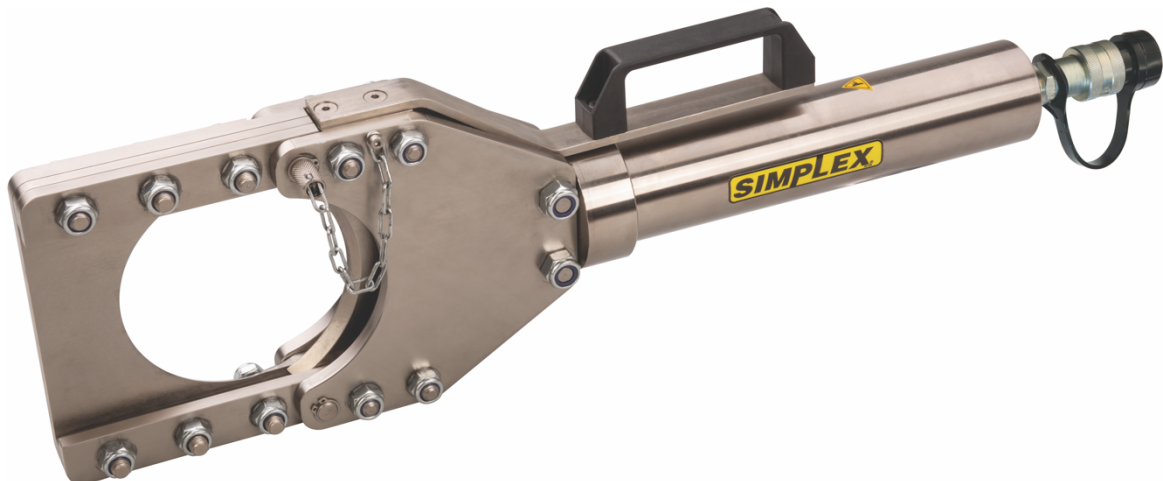

N86 W12500 Westbrook Crossing
Menomonee Falls, WI 53051 USA
Phone: 1-800-323-9114
Fax: 1-262-597-1127
Toll Free: (800) 323-9114
Email: sales@tksimplex.com
www.tksimplex.com

INDEX

1. **SAFETY REQUIREMENTS**2
 2. **TECHNICAL DATA**3
 3. **OPERATION**.....3
 4. **MAINTENANCE**.....4
 5. **ADDITIONAL INFORMATION**4
 6. **ASSEMBLY DIAGRAMS AND REPAIR PARTS LISTS**5

1. SAFETY REQUIREMENTS

GENERAL CONSIDERATIONS

The SIMPLEX hydraulic cutters have been designed in accordance with our quality standards and ISO 9001 rules.



The cutter must be used in accordance with the relevant instructions described in the manual. The user must be aware of the inherent risks when handling high pressure hydraulic devices and ensure that a safe working environment and safe systems of work are in place before operating the equipment.

The tool is designed only for the operations described in this manual. The manufacturer is not responsible for any damage caused by incorrect operation of the tool.

SAFETY PRINCIPLES

1. This manual must be always available to the operator and all safety and operational instructions must be followed.
2. The operator should be trained about the machine operation and the corresponding safety rules regarding prevention of accidents and protection of the environment.
3. The operator must wear personal protective equipment like helmet, glasses, gloves, boots, protective clothing, etc.



Helmet



Glasses



Gloves



Boots



Protective Clothing

4. The operator must be trained in the use and safe operation of the pump being used with the cutter. If a powered pump (electric, air, engine driven, etc.) is being used, all personnel must be aware that the blade will advance immediately when the system is pressurized and hydraulic flow is directed to the cutter.
5. All personnel must keep fingers, hands and other body parts away from the cutter blade to prevent serious personal injury.
6. Do not modify the tool in any way.
7. Follow suggested maintenance operations periodically as recommended in this manual.
8. All repairs should be performed by a qualified technician with genuine SIMPLEX parts. For further information, contact your nearest SIMPLEX authorized service center.
9. After operation, the tool should be cleaned and stored in a clean, dry and secure location.

GENERAL SAFETY INSTRUCTIONS



Before use, visually inspect the tool and accessories for any damage. If any damage is found, do not use the tool until repaired. Ensure that all the components of the hydraulic system can support the maximum pressure.

Before operation, make sure the operator is on solid footing in a well-lit area.



Manufacturer’s rating is the maximum allowable limit. Good practice encourages using only 80% of the manufacturer rating.



Keep the tool away from flames and heat, such as during welding.

- Tool plunger must be advanced before performing blade replacement. After advancing plunger, disconnect power to pump (if electric, air or engine driven) to prevent accidental pump start-up and possible serious injury. Perform all other maintenance operations with all pressure relieved (0 psi/bar) and hose disconnected from tool.
- Do not exceed equipment ratings. Use gauges or appropriate indicator devices to be aware of the working pressure.
- After operation, clean the tool and store it in a clean, dry and secure location.
- When using a powered pump, make sure that the valve is set to the neutral position before connecting the tool.
- Ensure that the pump reservoir is full. Always check oil level with cutter blade fully retracted.
- Ensure that heavy or sharp objects are positioned away from the hoses.
- When working with wire rope, fraying may occur during the cutting operation. To help prevent this, bind the wire rope on both sides of the cutting blade with tape or wire.

2. TECHNICAL DATA

MODEL	HCCS4750	
TOOL SPECIFICATIONS	Imperial	Metric
Capacity	12.2 Ton	109 kN
Pressure	10,150 psi	700 bar
Weight	25.7 lb	11.7 kg
Length†	25.0 in	635 mm
Width†	7.2 in	183 mm
Height†	3.1 in	80 mm
Max Jaw Opening†	4.8 in	122 mm
CUTTING CAPACITIES*		
Wire Rope		
Steel	Not Recommended	
Aluminum	1.37 in	35 mm
Cable		
Telephone	4.72 in	120 mm
Lead	4.72 in	120 mm
Underground	4.72 in	120 mm

† Due to rounding, the dimensions listed in this chart may be slightly different than the dimensions shown in the diagrams in Section 6.

*Maximum diameter material that can be cut.

3. OPERATION

1. Connect the cable cutter coupler to the hose coupler. Firmly tighten the couplers to prevent restricted oil flow.
2. On vented pumps, be sure that vent/fill cap (if equipped) is in the “VENT” position to allow proper pump functioning.
3. Close the pump release valve.
4. Remove the air trapped in the hydraulic circuit by operating the pump and fully advancing and retracting the cutter blade several times. Open the pump release valve to retract the blade.
5. Remove the retaining pin (attached to chain) and open the cutting head.
6. Place the material to be cut inside the cutting head. Then, close the cutting head and secure it with the retaining pin. Make sure the retaining pin is fully installed.
7. Operate the pump and advance the blade. Continue advancing the blade until the material is fully cut.
8. After cutting is completed, retract the blade back by opening the pump release valve. Open the head and remove all traces of material before making another cut.

4. MAINTENANCE

1. After use, the tool should be cleaned. Lubricate the area where the blade comes into contact with the head.
2. Ensure all fasteners are securely fastened.
3. In the event of oil leaks or improper functioning, contact the nearest SIMPLEX authorized service center for inspection and repair.

CHANGING THE BLADE

Note: Refer to Section 6 of this manual for parts list and item numbers. To help prevent damage to the tool, always perform blade replacement procedures in a clean and dry work area.



Blade must be advanced to provide access to blade retaining screw. To prevent possible serious injury, stop pump and disconnect power (if using a powered pump) after advancing blade.

Operate the pump until the blade moves out far enough to provide access to the blade retaining screw (17). Remove the screw (17) and remove the old blade. Mount a new blade and check that the orientation is correct (see diagram, below). Apply Loctite 242 thread sealant to threads of screw (17). Reinstall the screw (17) and tighten it to a torque of 531-620 in-lb [720-841 Nm]. Retract the blade after completing blade replacement procedures.

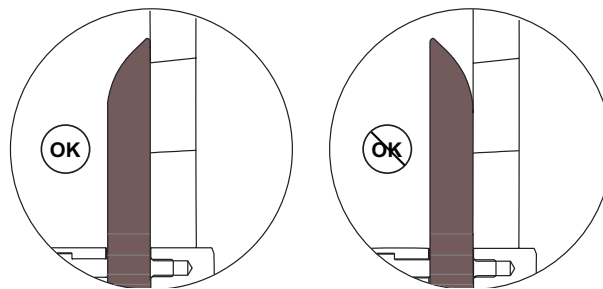

5. ADDITIONAL INFORMATION

All information, illustrations and specifications in this operation manual are based on the latest information available at the time of publication. The right is reserved to make changes at any time without notice.

Equipment operators and installers shall be responsible for ensuring that a safe working environment and safe systems of work are in place before operating the equipment.

Simplex declares that this product has been tested and conforms to applicable standards and complies with all CE requirements.

6. ASSEMBLY DIAGRAMS AND PARTS LISTS

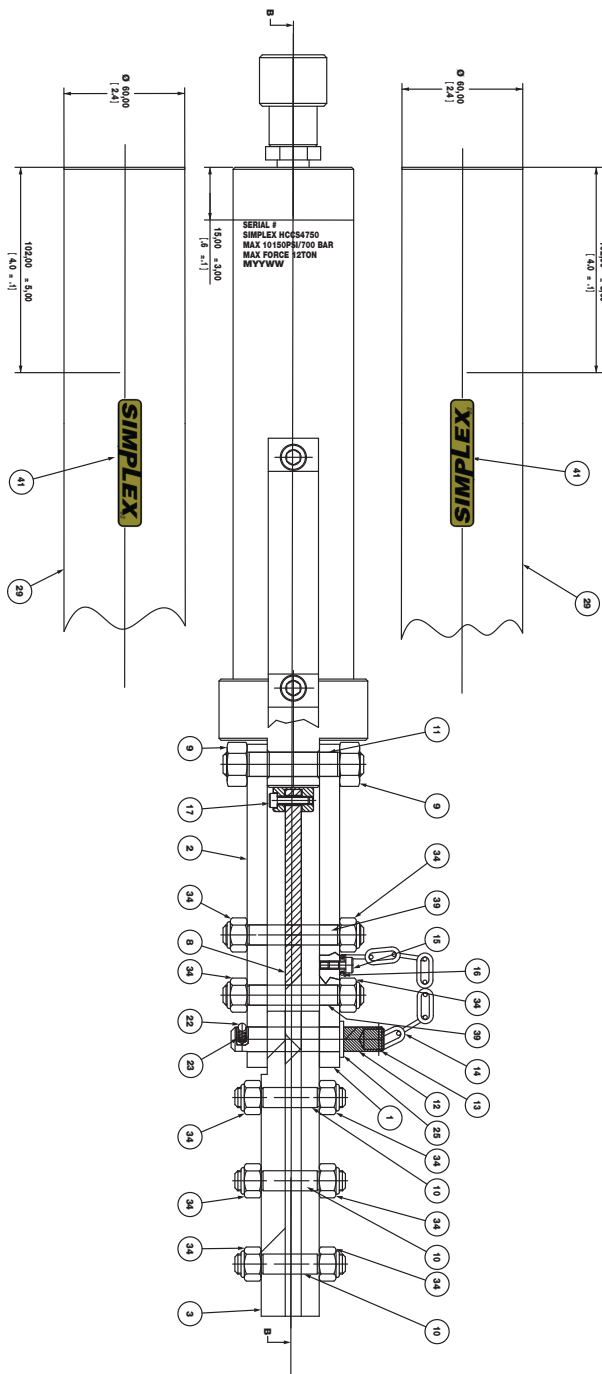

SECTION B-B

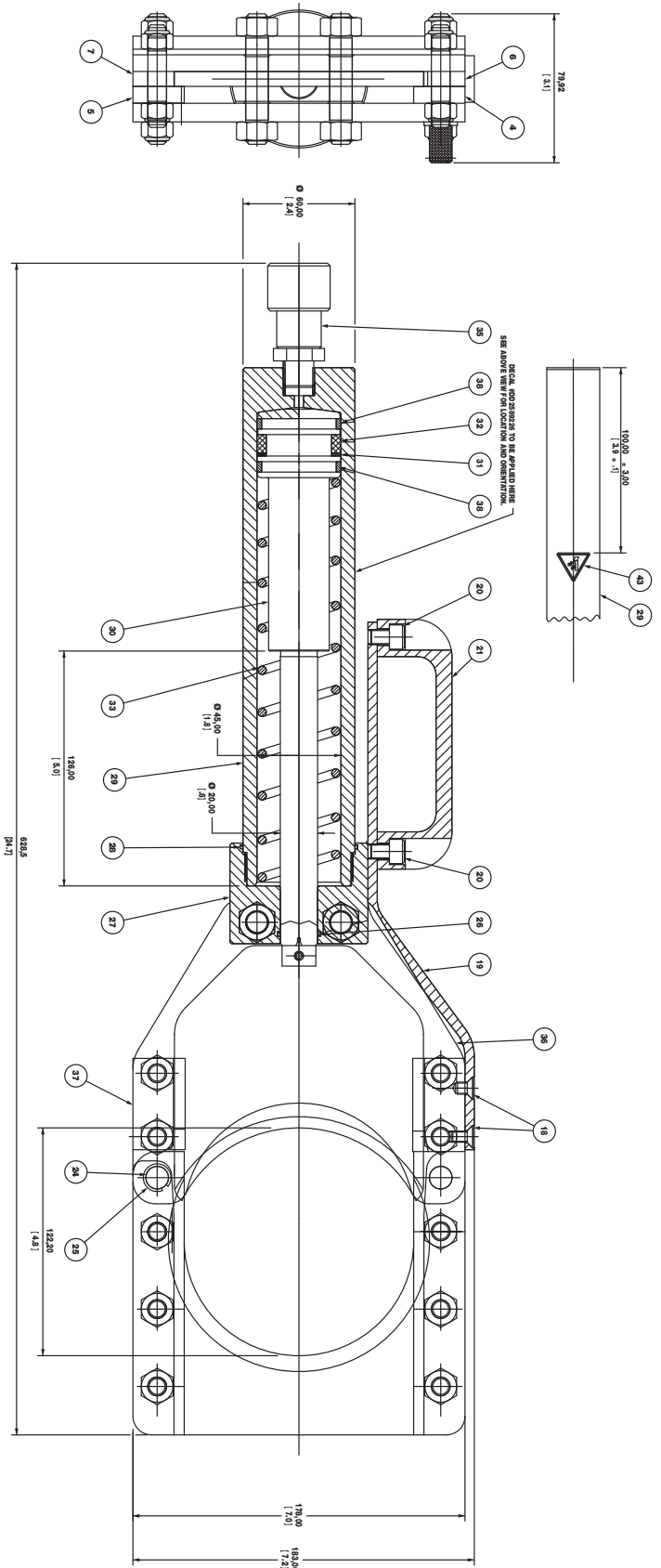



ITEM NUMBER	DESCRIPTION	QTY
1	UPPER PLATE BASE	1
2	LOWER PLATE BASE	1
3	COUNTER BLADE	1
4	RIGHT GUIDE BASE	1
5	LEFT GUIDE BASE	1
6	RIGHT GUIDE INTERMEDIATE BASE	1
7	LEFT GUIDE INTERMEDIATE BASE	1
**8	BLADE	1
9	SELF LOCKING NUT M12 DIN-985	4
10	SADDLE SHAFT	6
11	SHAFT	2
12	RETAINING PIN	1
13	ELASTIC PIN DIN 1481 Ø2 x 12	1
14	11 LINK CHAIN Ø2 A=8 L=18	1
15	ALLEN SCREW M4 x 5 DIN 912 8.8	1
16	STANDARD WASHER FOR M4	1
17	ALLEN SCREW M4 x 15 DIN 912 12.9	1
18	CHEESE COUNTERSINK HEAD SCREW M6 x 8 DIN 7991 12.9	1
19	HANDLE BASE	1
20	ALLEN SCREW M8 x 12 DIN 912 12.9	2
21	TECNODIN HANDLE 1157 13 200	1
22	BALL Ø4	1
23	SPRING	1
24	SADDLE PIN	1
25	ELASTIC RING FOR Ø12 DIN 471	3
*26	O-RING Ø20 x 2	1
27	SADDLE	1
*28	O-RING Ø60.04 x 1.78	1
29	BODY	1
30	PISTON	1
*31	SEGMENT	1
*32	COLLAR Ø35 x Ø45 x 9	1
33	SPRING	1
34	SELF LOCKING NUT M10 DIN-985	20
35	FEMALE BALL QUICK COUPLER 3/8NPT	1
36	RIGHT BLADE GUIDE	1
37	LEFT BLADE GUIDE	1
*38	GUIDE RING Ø45 x Ø40 x 5.6	2
39	SHAFT	4
41	SIMPLEX DECAL #88187	2
43	SAFETY DECAL #DD2589226	1

* Included in service kit HCCS4750K. ** Included in blade kit HCCS4750B.

SIMPLEX[®]