

# Specification

Maximum Operating Pressure (psi)	10,000
Capacity Class (tonnage)	100
Maximum Cylinder Capacity Advance (tons)	113
Stroke (in)	5.91
Collapsed Height A (in)	11.3
Extended Height B (in)	17.2
Return Type	Single-Acting, Load Return
Plunger Type	Solid
Material	Steel
Cylinder Effective Area Advance (in <sup>2</sup> )	22.19
Oil Capacity Advance (in <sup>3</sup> )	131.02
Sideload Resistance of Maximum Capacity (percentage)	10%
Surface Treatment	Nitride
Coupler	CR400 Coupler
Weight (lbs)	118

# Dimensions

Collapsed Height A (in)	11.3
Collapsed Height With Optional Tilt Saddle A1 (in)	11.89
Optional Tilt Saddle Addition To Collapsed Height A1 (in)	0.59
Optional Tilt Saddle Diameter J1 (in)	2.8
Extended Height B (in)	17.2
Outside Diameter D (in)	6.89
Cylinder Bore Diameter E (in)	5.31
Base to Advance Port H (in)	1.3
Saddle Diameter J1 (in)	2.8
Saddle Protrusion from Plunger K (in)	0.08
Saddle Maximum Tilt Angle Radius (degrees)	5
Base Mounting Holes Thread V	M12 x 1,75

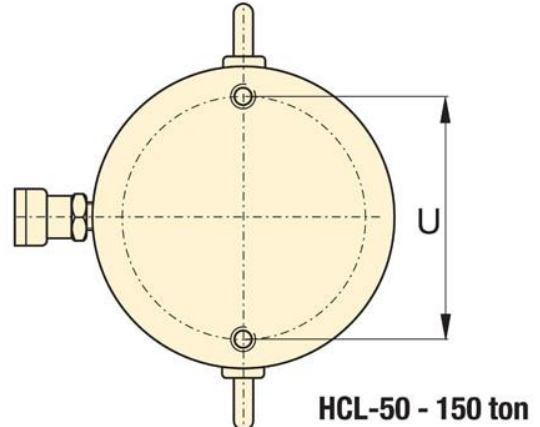
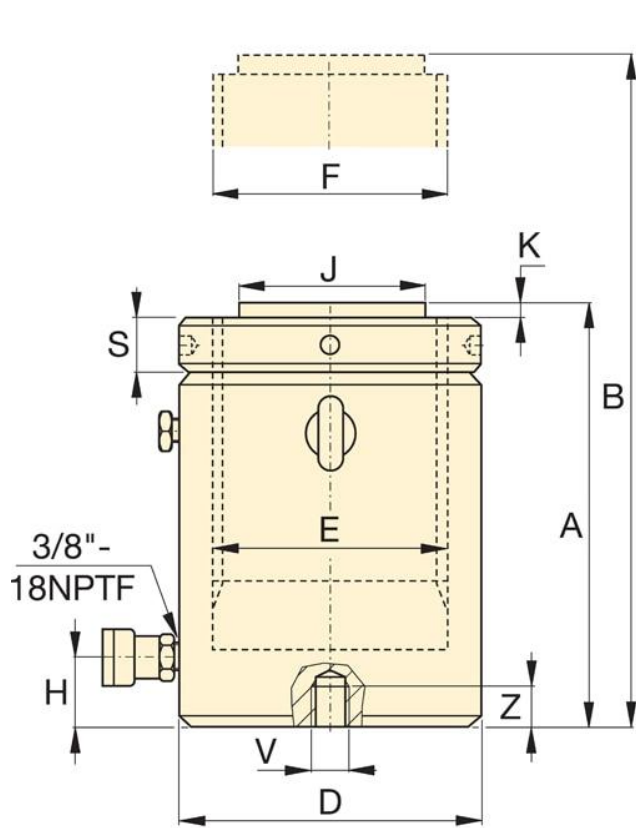

**HCL-50 - 150 ton**

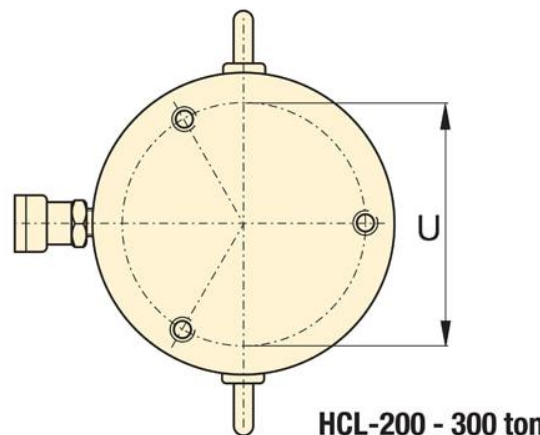

**HCL-200 - 300 ton**