

L4247 Rev. A 03/18

<i>Table of Contents:</i>	
<i>Section</i>	<i>Page</i>
1.0 IMPORTANT RECEIVING INSTRUCTIONS	1
2.0 SAFETY	1
3.0 CONFORMANCE TO NATIONAL AND INTERNATIONAL STANDARDS	3
4.0 PRODUCT DESCRIPTION	3
5.0 LIFTING THE CYLINDER	4
6.0 SETUP	4
7.0 AVOIDING SIDE LOAD	5
8.0 OPERATION	5
9.0 INSPECTION, MAINTENANCE & STORAGE	5
10.0 RELIEVING TRAPPED PRESSURE	5
11.0 TROUBLESHOOTING	6
12.0 PRODUCT DATA.	7

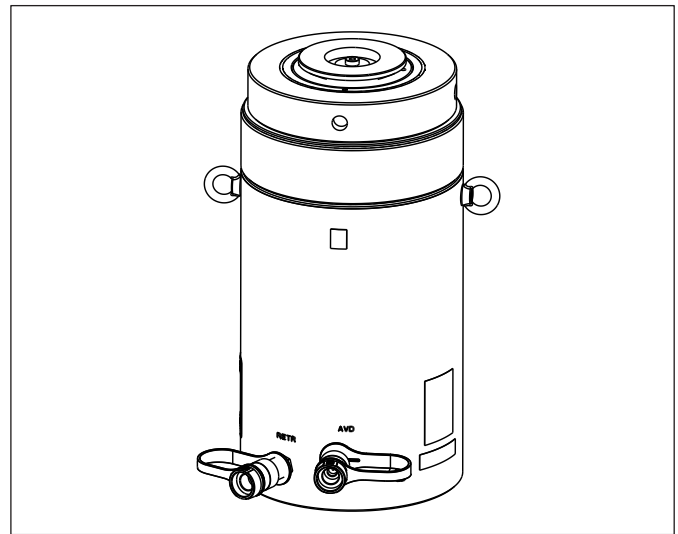

Safety Alert Symbols are used in conjunction with certain Signal Words that call attention to safety messages or property damage messages and designate a degree or level of hazard seriousness. The Signal Words used in this manual are WARNING, CAUTION and NOTICE.

1.0 IMPORTANT RECEIVING INSTRUCTIONS

Visually inspect all components for shipping damage. Shipping damage is not covered by warranty. If shipping damage is found, notify carrier at once. The carrier is responsible for all repair and replacement costs resulting from damage in shipment.

2.0 SAFETY

2.1 Introduction

Read all instructions carefully. Follow all recommended safety precautions to avoid personal injury as well as damage to the product and/or damage to other property. Enerpac cannot be responsible for any damage or injury from unsafe use, lack of maintenance or incorrect operation. Do not remove warning labels, tags, or decals. In the event any questions or concerns arise, contact Enerpac or a local Enerpac distributor for clarification.

If you have never been trained on high-pressure hydraulic safety, consult your distributor or service center for information about an Enerpac Hydraulic Safety Course.

This manual follows a system of safety alert symbols, signal words and safety messages to warn the user of specific hazards. Failure to comply with these warnings could result in death or serious personal injury, as well as damage to the equipment or other property.

 The **Safety Alert Symbol** appears throughout this manual. It is used to alert you to potential physical injury hazards. Pay close attention to Safety Alert Symbols and obey all safety messages that follow this symbol to avoid the possibility of death or serious personal injury.

 **WARNING** Indicates a hazardous situation that, if not avoided, **could** result in death or serious personal injury.

 **CAUTION** Indicates a hazardous situation that, if not avoided, **could** result in minor or moderate personal injury.

 **NOTICE** Indicates information considered important, but not hazard related (e.g. messages relating to property damage). Please note that the Safety Alert Symbol will **not** be used with this signal word.

2.2 Hydraulic Cylinder Safety Precautions (HCRL-Series)

 **WARNING**

Failure to observe and comply with the following precautions could result in death or serious personal injury. Property damage could also occur.

- Read and completely understand the safety precautions and instructions in this manual before operating the cylinder or preparing it for use. Always follow all safety precautions and instructions, including those that are contained within the procedures of this manual.
- Operating procedures will vary, depending on the system arrangement and the specific components being used. Always read, follow and completely understand all manufacturer's instructions when operating pumps, valves and all other devices used with the cylinders. Follow all safety precautions contained in the manufacturer's manuals.
- Always wear appropriate personal protective equipment (P.P.E.) when operating hydraulic equipment. Be sure to wear eye protection, work gloves and protective clothing.

Use of additional P.P.E. safety items such as dust mask, non-skid safety shoes, hard hat, and hearing protection (used as appropriate for the conditions) will reduce the chance of personal injuries. The use of these items may also be required by local regulations or laws.

- Do not handle pressurized hoses. Escaping oil under pressure can penetrate the skin. If oil is injected under the skin, see a doctor immediately.
- Do not pressurize disconnected couplers.
- Use hydraulic cylinders only in a coupled system. It is acceptable to use a cylinder with a disconnected coupler only if the load is mechanically supported by the cylinder lock nut, and all hydraulic pressure is completely relieved.
- When holding loads, be certain that the lock nut is turned down firmly against the cylinder base so that the load is mechanically supported. Also be sure that all hydraulic pressure is completely relieved.
- Do not remove or disable the pump relief valve.
- Do not remove or disable the cylinder relief valve (if equipped).
- The system operating pressure must not exceed the pressure rating of the lowest rated component in the system.
- Install pressure gauge(s) in the system to monitor operating pressure. It is your window to see what is happening in the system.
- Never set a relief valve to a higher pressure than the maximum rated pressure of the pump and cylinder. If ratings are different, relief valve setting should not exceed the setting of the lowest rated component (pump or cylinder).
- The HCRL-Series cylinders are designed for a maximum working pressure of 10150 psi [700 bar]. Do not connect a pump with a higher pressure rating to these cylinders.
- Do not exceed equipment ratings. Never attempt to lift a load weighing more than the rated capacity of the cylinder. Overloading may cause equipment failure and possible personal injury.
- Be sure setup is stable before lifting load. Cylinders should be located on a firm and level surface capable of supporting the full load.
- Where applicable, use a cylinder base plate to provide added stability. If desired, the cylinder can be bolted to the base plate, using the bolt holes in the bottom of the cylinder base.
- Do not weld, drill or otherwise modify a cylinder to attach a base plate or other support unless approved in writing by Enerpac Engineering Department. Use only the provided bolt holes.
- Always perform a visual inspection of the cylinder before placing it into operation. If any problems are found, do not use the cylinder. Have the cylinder repaired and tested before it is returned to service.
- Never use a cylinder that is leaking oil. Do not use a cylinder that is damaged, altered or in need of repair.
- Always lift the cylinder using a hoist, crane or other suitable lifting device of sufficient rated capacity. Use only the supplied cylinder lifting eyes to attach the cylinder to the lifting device. Replace any missing or damaged lifting eyes.
- Allow only trained and experienced personnel to supervise and perform lifting and lowering procedures.
- Be certain that no persons are working on or near any cylinders before lifting or lowering of the load begins. Alert all personnel in advance that lifting or lowering is about to occur.
- Use suitable cribbing of rigid construction to hold loads.
- Never use a hydraulic cylinder as a shim or spacer in any lifting or pressing application.
- Be certain that the load is centered and covers the entire plunger saddle surface. Avoid situations where loads are not directly centered on the plunger saddle. The load may slip or fall, causing potential danger.
- Lift only dead weight loads. Avoid lifting live weight loads.
- Be especially careful when lifting loads such as partially filled storage tanks, in which the center of gravity could move or shift during lifting. Be aware that the distribution of some loads can change quickly and without warning.
- Do not use the cylinder to lift people. Do not allow people to be on top of the load during lifting or lowering.
- Keep all personnel clear of the work area while lifting or lowering is in progress. To avoid personal injury, keep hands and feet away from cylinder and load during operation.
- Maintain communication with the operator at all times during lifting or lowering to avoid accidents. Use hand signals, two-way radios or other appropriate forms of communication (as required by applicable laws and regulations) if the load is not visible to the operator.
- Operate pump and valve as required to ensure that the load is lifted and lowered evenly and at a controlled rate.
- Closely watch the load at all times during lifting and lowering. Stop lifting or lowering immediately if the load becomes unstable or appears to be lifting or lowering unevenly.
- Stay clear of loads supported only by hydraulics. As required, follow the lifted load with cribbing.
- Never allow persons to work under or near the load while the load is being supported hydraulically. After the load has been raised or lowered, it always must be blocked mechanically by the cylinder lock nut or via suitable cribbing.
- Always be certain that hydraulic pressure is fully relieved and that the load is fully removed from the cylinder(s) before disconnecting hydraulic hoses, loosening hydraulic fittings, or performing any cylinder disassembly or repair procedures.

CAUTION

Failure to observe and comply with the following precautions could result in minor or moderate personal injury. Property damage could also occur.

- Be careful to avoid damaging hydraulic hoses. Avoid sharp bends and kinks when routing hydraulic hoses. Do not exceed the minimum bend radius specified by the hose manufacturer. Using a bent or kinked hose will cause severe back-pressure. Sharp bends and kinks will internally damage the hose, leading to premature hose failure.
- Do not drop heavy objects on hoses. A sharp impact may cause internal damage to hose wire strands. Applying pressure to a damaged hose may cause it to rupture.
- Do not lift hydraulic equipment by the hoses or couplers. Use the cylinder lifting eyes and appropriately rated lifting equipment.
- Keep hydraulic equipment away from flames and heat. Excessive heat will soften packings and seals, resulting in fluid leaks. Heat also weakens hose materials and packings.
- For optimum performance, do not expose hydraulic equipment to temperatures of 150°F [65°C] or higher. Protect all hydraulic equipment from weld spatter.
- Immediately replace worn or damaged parts with genuine Enerpac parts. Enerpac parts are designed to fit properly and to withstand high loads. Non-Enerpac parts may break or cause the product to malfunction.

NOTICE

- Hydraulic equipment must only be serviced by a qualified hydraulic technician. For repair service, contact the Enerpac Authorized Service Center in your area.
- To help ensure proper operation and best performance, use of Enerpac oil is strongly recommended.

2.3 Crush and Pinch Point Hazard (HCRL-Series)

⚠ WARNING Never reach in between the cylinder lock nut and the top of the cylinder base. Serious personal injury can occur if cylinder is retracted and hands, fingers or other body parts are present in this area. See Figure 1.

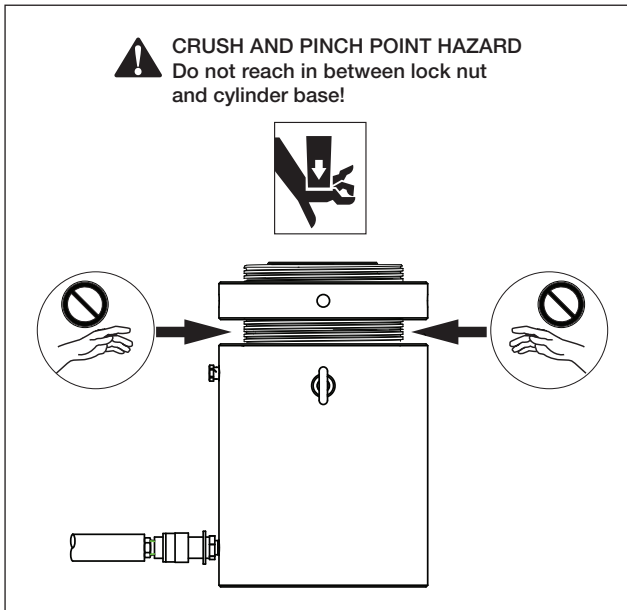

Figure 1, Crush and Pinch Point Hazard

2.4 Additional Safety References

Consult the applicable industry and/or government standards in your country or region for additional safety precautions and work rules applicable to hydraulic cylinders, jacks and other similar lifting equipment.

In the USA, refer to the following publications:

- Code of Federal Regulations - Title 29 Occupational Safety and Health Standards (U.S. Government Publishing Office, 732 North Capitol Street, NW, Washington, DC 20401-0001. www.gpo.gov).
- ASME B30.1 Standards - Jacks (American Society of Mechanical Engineers, Two Park Avenue, New York, NY 10016-5990. www.asme.org).

In the European Union, refer to the standards and directives listed in the product's EU Declaration of Incorporation. A copy of this document is packed separately with the cylinder.

3.0 CONFORMANCE TO NATIONAL AND INTERNATIONAL STANDARDS

CE Enerpac declares that this product has been tested and conforms to applicable standards and is compatible to all CE Requirements. A copy of an EU Declaration of Incorporation is enclosed with each shipment of this product.

4.0 PRODUCT DESCRIPTION

Enerpac HCRL-Series cylinders are an ideal solution for a wide variety of commercial and industrial lifting applications.

HCRL-Series cylinders are double-acting with hydraulic advance and return. A lock nut provides mechanical load holding capabilities.

The hydraulic return feature allows greater control during lowering and provides positive retraction of the plunger. Note that the HCRL-Series cylinders are not designed for pulling applications.

Capacities range from 62 to 1196 US tons [550 to 10644 kN]. Refer to the product data markings on the cylinder base for the capacity rating of your cylinder model.

All standard production HCRL-Series cylinders are designed for 10150 psi [700 bar] maximum working pressure.

An integrated tilt saddle is standard equipment on all models.

Refer to Section 12 of this manual for cylinder weights, oil volumes, dimensions and additional specifications.

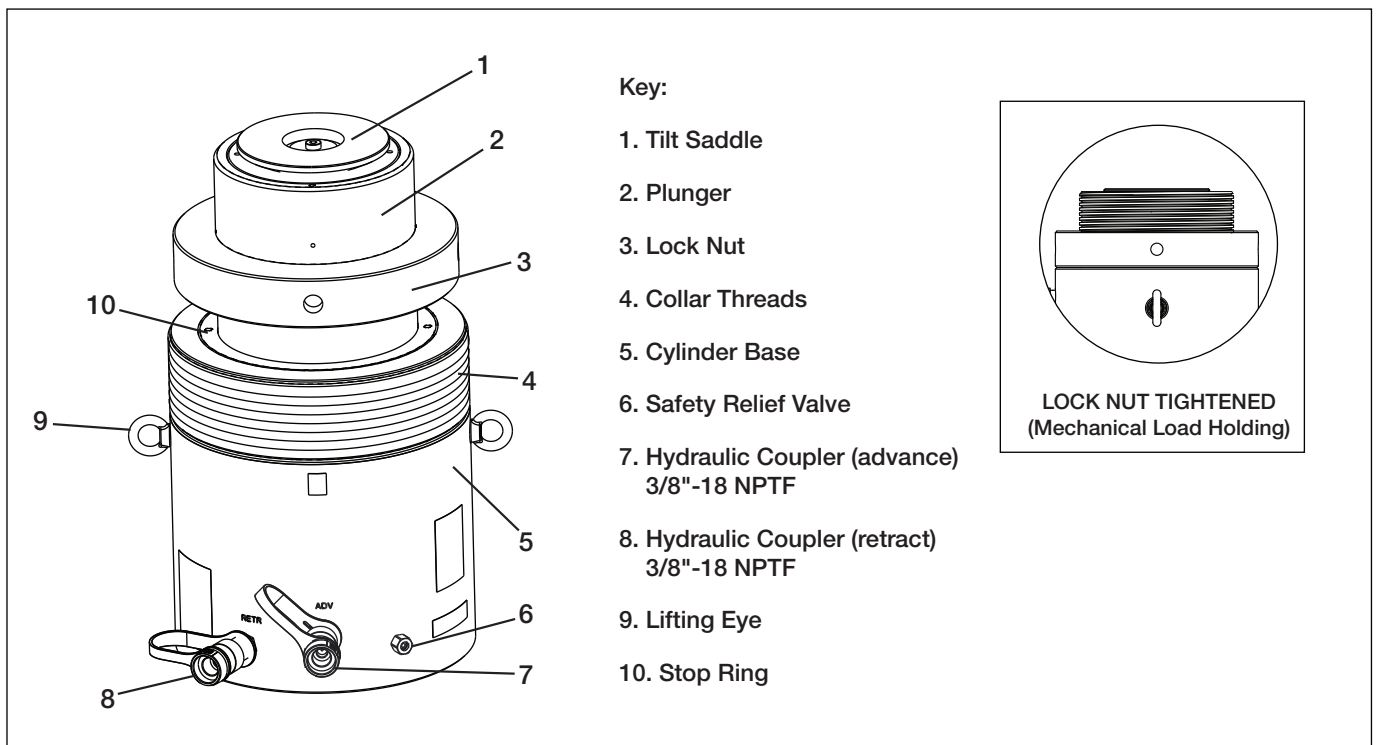

Figure 2, Major Features and Components

5.0 LIFTING THE CYLINDER

All HCRL-Series cylinders are equipped with TWO pre-installed lifting eyes. Always use both lifting eyes when hoisting the cylinder.

Lifting straps or chains must be positioned at an angle where they will not interfere with the cylinder base. Use of a spreader bar is recommended. See Figure 3.

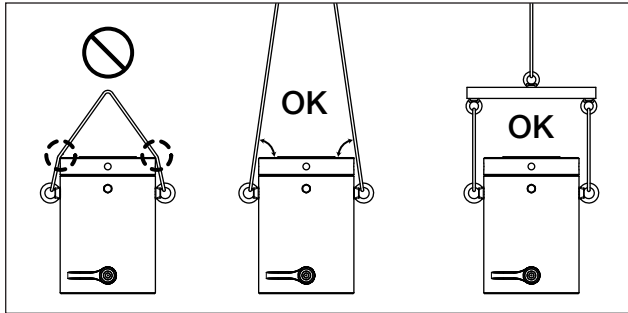

Figure 3, Lifting Arrangements (typical)

6.0 SETUP

6.1 Hydraulic Pump Requirements

Hydraulic pumps are sold separately and are not included with the cylinders.

A hand-operated hydraulic pump can be used to operate a smaller HCRL-Series cylinder. However, a large size cylinder (or a series of coupled cylinders) will typically require the use of an electric, air or gas powered hydraulic pump.

Whichever type of pump is used, be certain that the pump reservoir is capable of holding a sufficient amount of hydraulic oil to operate the cylinder (or set of cylinders) to full extension.

The pump must be equipped with a four-way directional control valve. This valve may be either manual or remote operated.

The pump must also be equipped with a separate safety pressure relief valve that opens if the system working pressure exceeds 10150 psi [700 bar]. Verify that the pump safety relief valve is adjusted to the proper setting before using the pump with the cylinder(s).

6.2 Hydraulic Oil Requirements

Use of Enerpac HF Series ISO 32 hydraulic oil is recommended. Enerpac HF oil is available at your local Enerpac Distributor or Authorized Service Center.

NOTICE

- Failure to use the correct oil type (high-quality ISO 32 hydraulic oil) may result in damage to cylinder hydraulic components and will void the product warranty.
- Be sure that the oil is clean. The oil cleanliness should be maintained to a maximum level of 18/16/13 per the ISO 4406 standard. If the oil develops a milky, cloudy or dark appearance, it should be changed immediately.
- To avoid overfilling and possible equipment damage, add oil to the pump reservoir only after all cylinder plungers are completely retracted and system pressure is released.
- When using a hand-operated pump to power the cylinder(s), it is permissible to use a high-quality brand of ISO 15 hydraulic oil. The lower oil viscosity will result in reduced pumping effort, especially in cold weather conditions.

6.3 Hydraulic Connections

HCRL-Series cylinders are equipped with two 3/8"-18 NPTF female couplers, one for advance side hydraulic flow and one for retract side hydraulic flow.

Refer to Figure 2, items 7 and 8 for locations.

Be certain that all couplers are fully connected, so that hydraulic flow is not blocked or restricted.

All hoses, fittings and other hydraulic components in the circuit must be rated for at least 10150 psi [700 bar] operation.

NOTICE HCRL-Series cylinders are double-acting. In both operational modes, return oil flow (from the non-pressurized side of the cylinder) must be directed back to the hydraulic reservoir. Check for proper flow before placing the equipment into operation.

6.4 Air Removal

Trapped air must be removed from the hydraulic cylinder and hoses before placing the system into operation. If multiple cylinders are to be used, it is recommended that air be removed from each cylinder individually. Refer to the following procedure:

1. Place the cylinder in the vertical position, with the base located on a flat and level surface. Be sure that there is no load on the plunger.
2. Verify that the lock nut is positioned at the top of the plunger. This will allow the plunger to be fully retracted during the air removal process.
3. Position the hydraulic pump so it is located *higher* than the cylinder.
4. Fully advance and retract the plunger, being careful to avoid pressure build-up at full extension and full retraction. Repeat this process until plunger motion is smooth in both directions.
5. Fully retract the plunger after completing air removal procedures. Check oil level in pump hydraulic reservoir. Add oil if oil level is low.
6. Repeat steps 1 through 5 for all cylinders to be used in the hydraulic circuit.

NOTICE Refer to Section 6.2 of this document for hydraulic oil requirements. Follow the pump manufacturer's instructions when adding oil to the pump reservoir. To avoid overfilling, be certain that the cylinder plunger is fully retracted before adding any oil.

6.5 Cylinder Base Support

Be certain to provide adequate support for the cylinder base. All HCRL-Series cylinders require a flat and stable lifting surface that is capable of supporting the load without settling. A steel plate or steel bars of appropriate size should be placed between the cylinder base and the ground or other lifting surface. See Figure 4.

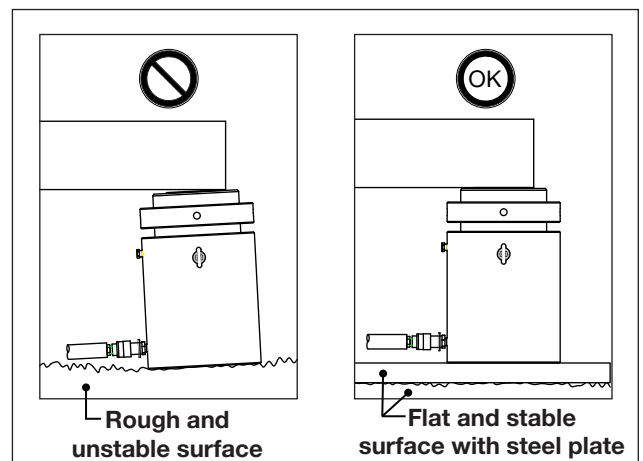

Figure 4, Cylinder Base Support

CAUTION Use of HCRL-Series cylinders on surfaces such as sand, mud or dirt may result in loss of load and/or damage to cylinder.

Base mounting holes are provided on all models. Refer to sections 12.1 and 12.2 for mounting hole locations and dimensions. Mounting bolts are not included with the cylinder and must be provided by the user.

7.0 AVOIDING SIDE LOAD

Plan ahead to eliminate the presence of side load forces (offset loading) when using hydraulic cylinders. Side load can occur as a result of one or more of the following conditions:

- An eccentric load on the plunger.
- A horizontal load on a structure.
- A shifting center of gravity.
- Structure and/or cylinder misalignment.
- Non-synchronized lifting actions.
- Non-stable cylinder base support.

It is understood that some side load will occur in many lifting situations. However, the user should do everything possible to minimize or eliminate this condition.

The possibility of side load can be reduced by ensuring that the cylinder base is located on a flat and hard surface, capable of supporting the cylinder and the load without settling.

To help reduce the effects of minimal side load that cannot be eliminated, all HCRL-Series cylinders are equipped with an integral tilt saddle. The tilt saddle helps compensate for initial misalignment of the load and the saddle surface. It reduces saddle edge loading, which can result in an undesirable off-center load being applied to the plunger.

8.0 OPERATION

Operation procedures will vary, depending on hydraulic pump type, valve configuration and other factors. For detailed operating instructions and related information, refer to the instruction sheet included with your pump. Also follow the additional instructions and precautions contained in sections 8.1 and 8.2 of this manual.

If using multiple HCRL-Series cylinders: Without load, verify that all plungers advance and retract in the same direction when the control valve is shifted. If necessary, relieve pressure and properly reconnect any reversed hydraulic hoses.

8.1 Operating Instructions

WARNING To prevent serious personal injury, keep hands, fingers and other body parts clear of pinch point area between lock nut and cylinder base during cylinder operation (refer to Section 2.3 for additional details). Be certain that plunger is not moving when tightening or loosening lock nut.

To advance: Operate pump and valve so that pressurized oil flow is directed in a controlled rate from the pump reservoir to the cylinder advance coupler.

To hold the load: Tighten the lock nut until it is snug against the top edge of the cylinder base. This will mechanically prevent the plunger from retracting when hydraulic pressure is relieved.

To loosen lock nut: Advance the plunger about 1/4 inch [6 mm] to remove any weight from the lock nut. Then, loosen the lock nut the desired number of turns, using a tommy bar of appropriate diameter.

To retract: Be sure that the locknut has been loosened a sufficient amount of turns, so that the plunger can be retracted the desired amount. Then, operate pump and valve so that pressurized oil flow is directed from the pump reservoir to the cylinder retract coupler. Note that additional hydraulic components may be required to control the rate at which the plunger retracts under load.

8.2 Retract Side Safety Relief Valve

HCRL-Series cylinders include a retract side safety relief valve. It is located near the bottom of the cylinder base. See Figure 2, item 6.

The valve is designed to relieve retract chamber pressure in the event that hydraulic flow is directed to the advance side of the cylinder while the retract side hose is disconnected. It is factory set at approximately 862-896 bar [12500-13000 psi].

WARNING Do not remove, alter or disable the retract side safety relief valve. Do not readjust the valve setting. Failure to observe this instruction may result in possible catastrophic failure of the cylinder. Serious personal injury could result.

9.0 INSPECTION, MAINTENANCE & STORAGE

- Periodically check the hydraulic system for loose connections leaks and obvious problems. Replace any damaged components immediately.
- Monitor the hydraulic oil temperature during operation. Do not exceed oil temperatures above 150°F [65°C].
- Install dust caps and plugs on all hydraulic couplers after the hydraulic hoses are disconnected from the cylinder.
- Keep all hydraulic components clean.
- Periodically check the tilt saddle for free movement. If required, disassemble, clean and lubricate the tilt saddle. Use white lithium grease.
- Change the hydraulic oil at the recommended interval shown in the pump instruction sheet. Change the oil immediately if contamination is suspected.
- Store cylinders in the vertical position, in a clean, dry and secure location. Keep stored cylinders and hoses away from heat and direct sunlight.
- If repairs are required, refer to the Enerpac website for the repair parts sheet applicable to your cylinder model.

NOTICE Hydraulic equipment must only be serviced by a qualified hydraulic technician. For repair service, contact the Enerpac Authorized Service Center in your area.

10.0 RELIEVING TRAPPED PRESSURE

Hydraulic pressure can sometimes become trapped within a hydraulic cylinder. This condition can occur in both single and double-acting cylinders, but is most likely to happen in a double-acting cylinder that has been exposed to changing ambient temperatures.

A common indication of trapped pressure is when mating hose and cylinder couplers will not engage, or are unusually difficult to engage.

If a trapped pressure condition is suspected, always use the Enerpac model CT-604 coupler bleed tool (available from your Enerpac distributor) to safely relieve any remaining pressure.

WARNING Never attempt to relieve trapped hydraulic pressure within the cylinder by loosening a coupler on the cylinder base.

Trapped hydraulic pressure can cause a loosened coupler to dislodge unexpectedly with great force. Serious personal injury or death will result if the coupler becomes a projectile and strikes persons working in the area.

A sudden escape of pressurized hydraulic oil may also occur if a coupler is loosened while trapped hydraulic pressure is present. Serious personal injury or death could result if a high pressure oil stream penetrates the skin.

Use only the Enerpac CT-604 coupler bleed tool to relieve trapped hydraulic pressure within the cylinder.

⚠ WARNING Never use a hammer and punch (or other similar method) to unseat a coupler check ball that is under pressure. Serious personal injury or death could result due to the sudden and uncontrolled escape of high pressure oil. Use only the Enerpac CT-604 coupler bleed tool to relieve trapped pressure within the cylinder.

11.0 TROUBLESHOOTING

Refer to the troubleshooting guide when diagnosing cylinder operational problems. Please note that the troubleshooting guide is not all-inclusive, and should be considered only as an aid to help diagnose the most common possible problems.

For repair service, contact your nearest Enerpac Authorized Service Center. As required, also refer to the troubleshooting information provided with your hydraulic pump or power unit.

<i>Troubleshooting Guide</i>		
Symptom	Possible Cause	Solution
1. Plunger will not advance.	a. Directional control valve not in proper position.	Shift directional control valve to proper position.
	b. Coupler not fully tightened.	Tighten coupler.
	c. Pump oil level is low.	Add oil to pump reservoir as required. See Section 6.2.
	d. Pump malfunctioning.	Repair or replace pump as required.
	e. Cylinder load rating too low for application.	Use a cylinder with a higher load rating.
	f. Cylinder seals leaking.	Repair or replace cylinder.
2. Plunger advances only part way.	a. Pump oil level is low.	Add oil to pump reservoir as required. See Section 6.2.
	b. Coupler is not fully tightened.	Tighten coupler.
	c. Cylinder plunger binding.	Repair or replace cylinder.
3. Plunger advances erratically.	a. Air in hydraulic system.	Remove air from hydraulic system. See Section 6.4.
	b. Cylinder plunger binding.	Repair or replace cylinder.
4. Plunger advances more slowly than normal.	a. Leaking connection.	Repair leaking connection.
	b. Coupler not fully tightened.	Tighten coupler.
	c. Pump malfunctioning.	Repair or replace pump as required.
5. Plunger advances, but will not hold.	a. Pump malfunctioning.	Repair or replace pump as required.
	b. Leaking connection.	Repair leaking connection.
	c. Incorrect system set-up.	Check hose connections at pump and cylinders.
	d. Cylinder seals leaking.	Repair or replace cylinder.
6. Cylinder leaks oil.	a. Loose connection.	Tighten or repair connection.
	b. Worn or damaged cylinder seals.	Repair or replace cylinder.
	c. Internal cylinder damage.	Repair or replace cylinder.
7. Plunger will not retract or retracts more slowly than normal.	a. Directional control valve not in proper position.	Shift directional control valve to proper position.
	b. Lock nut not loosened.	Loosen lock nut a sufficient amount of turns.
	c. Pump reservoir is overfilled.	Drain oil from pump reservoir as required.
	d. Improper hose connections.	Check hose connections.
	e. Narrow hose restricting oil flow.	Replace with larger diameter hose.
	f. Cylinder plunger binding and/or internal damage.	Repair or replace cylinder.
8. Oil leakage from external relief valve.	a. Coupler not fully tightened.	Tighten coupler.
	b. Restriction in return line.	Remove restriction from return line.
	c. Relief valve setting incorrect.	Check relief valve setting.
	d. Relief valve damaged or contaminated.	Repair or replace relief valve.

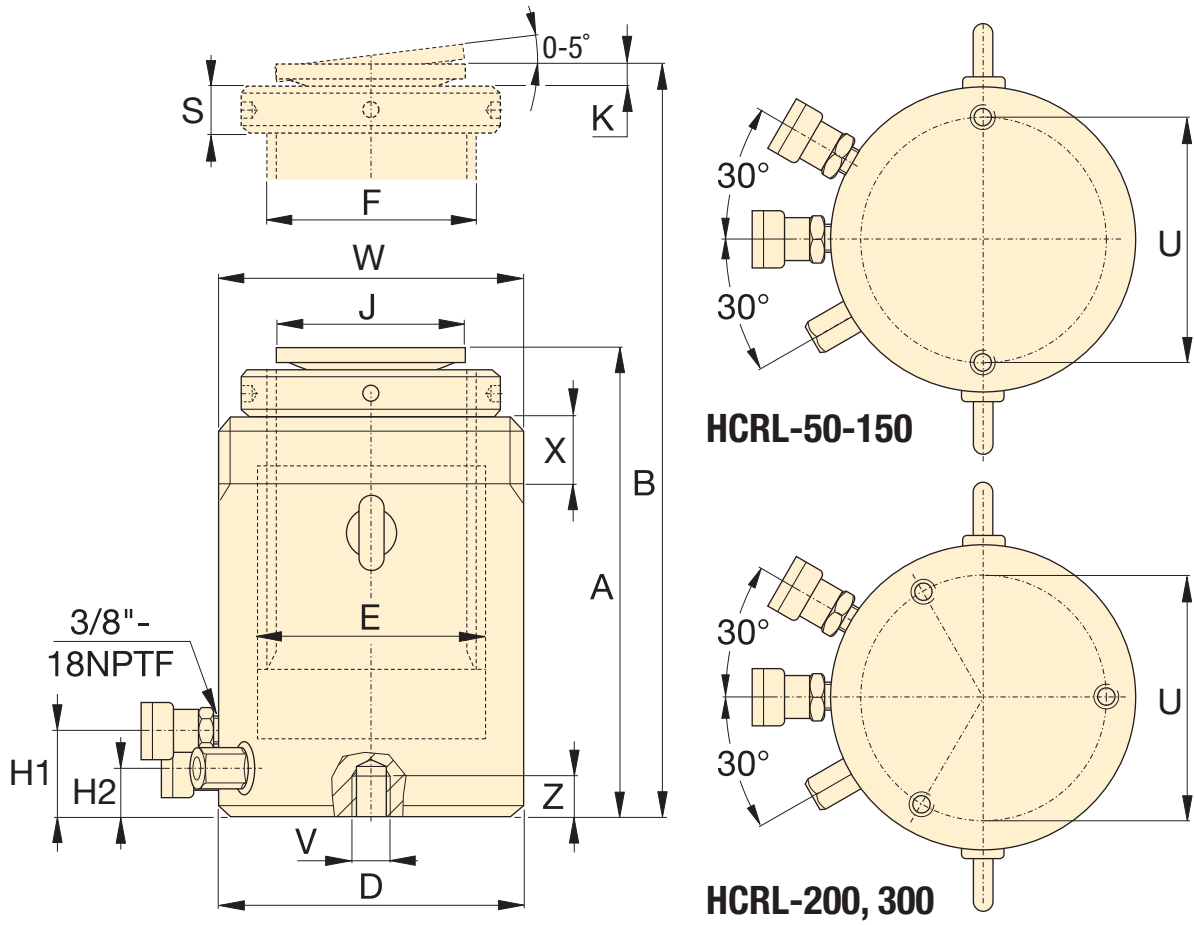

Refer to Sections 12.1 and 12.2 for the dimensions applicable to your cylinder model. Use this graphic as a reference.

Figure 5, Dimensions - HCRL-Series

12.1 Dimensions, HCRL-Series (imperial)

Cylinder Model Number	Collapsed Height	Extended Height	Outside Diameter	Cylinder Bore Diameter	Plunger Diameter (threaded)	Base to Advance Port	Base to Retract Port	Saddle Diameter
	A	B	D	E	F	H1	H2	J
	in	in	in	in	mm	in	in	in
HCRL-506	12.2	18.11	5.12	3.93	TR 90 x 4	1.61	1.04	3.02
HCRL-508	14.84	22.71	5.12	3.93	TR 90 x 4	1.61	1.04	3.02
HCRL-5010	16.81	26.65	5.12	3.93	TR 90 x 4	1.61	1.04	3.02
HCRL-5012	18.77	30.59	5.12	3.93	TR 90 x 4	1.61	1.04	3.02
HCRL-1006	13.62	19.52	7.28	5.51	TR 120 x 6	1.97	1.41	3.02
HCRL-1008	16.57	14.44	7.28	5.51	TR 120 x 6	1.97	1.41	3.02
HCRL-10010	18.54	28.38	7.28	5.51	TR 120 x 6	1.97	1.41	3.02
HCRL-10012	20.51	32.32	7.28	5.51	TR 120 x 6	1.97	1.41	3.02
HCRL-1506	14.13	20.03	8.74	6.69	TR 150 x 6	1.81	1.24	4.96
HCRL-1508	17.09	24.96	8.74	6.69	TR 150 x 6	1.81	1.24	4.96
HCRL-15010	19.06	28.90	8.74	6.69	TR 150 x 6	1.81	1.24	4.96
HCRL-15012	21.02	32.83	8.74	6.69	TR 150 x 6	1.81	1.24	4.96
HCRL-2006	15.70	21.61	10.24	7.87	TR 170 x 6	2.80	1.92	4.96
HCRL-2008	18.46	26.34	10.24	7.87	TR 170 x 6	2.80	1.92	4.96
HCRL-20010	20.43	30.28	10.24	7.87	TR 170 x 6	2.80	1.92	4.96
HCRL-20012	22.40	34.21	10.24	7.87	TR 170 x 6	2.80	1.92	4.96
HCRL-2506	16.38	22.28	11.42	8.66	TR 190 x 6	2.80	1.92	6.30
HCRL-2508	19.33	27.20	11.42	8.66	TR 190 x 6	2.80	1.92	6.30
HCRL-25010	21.30	31.14	11.42	8.66	TR 190 x 6	2.80	1.92	6.30
HCRL-25012	23.27	35.08	11.42	8.66	TR 190 x 6	2.80	1.92	6.30
HCRL-3006	16.57	22.48	12.40	9.45	TR 210 x 6	2.80	1.92	6.30
HCRL-3008	19.53	27.40	12.40	9.45	TR 210 x 6	2.80	1.92	6.30
HCRL-30010	21.50	31.34	12.40	9.45	TR 210 x 6	2.80	1.92	6.30
HCRL-30012	23.46	35.28	12.40	9.45	TR 210 x 6	2.80	1.92	6.30

• Refer to Figure 5 for dimensions graphic. • Imperial units of measure are used in this table (except as indicated).
 • Contact Enerpac for dimensions of custom ordered cylinders not shown above.

Cylinder Model Number	Saddle Protrusion	Lock Nut Height	Base Mounting Holes					Collar Thread	
			Bolt Circle	Thread Size	Minimum Thread Depth	Number of Holes	Angle From Coupler	Thread Size	Thread Length
			U	V	Z			W	X
			in	mm	in			mm	in
HCRL-506	0.57	1.02	4.13	M12 x 1.75	0.87	2	90°	M130 x 2	1.65
HCRL-508	0.57	1.02	4.13	M12 x 1.75	0.87	2	90°	M130 x 2	1.65
HCRL-5010	0.57	1.02	4.13	M12 x 1.75	0.87	2	90°	M130 x 2	1.65
HCRL-5012	0.57	1.02	4.13	M12 x 1.75	0.87	2	90°	M130 x 2	1.65
HCRL-1006	0.59	1.42	5.90	M12 x 1.75	0.87	2	90°	M185 x 2	2.24
HCRL-1008	0.59	1.42	5.90	M12 x 1.75	0.87	2	90°	M185 x 2	2.24
HCRL-10010	0.59	1.42	5.90	M12 x 1.75	0.87	2	90°	M185 x 2	2.24
HCRL-10012	0.59	1.42	5.90	M12 x 1.75	0.87	2	90°	M185 x 2	2.24
HCRL-1506	0.51	1.77	7.28	M12 x 1.75	0.87	2	90°	M222 x 3	2.76
HCRL-1508	0.51	1.77	7.28	M12 x 1.75	0.87	2	90°	M222 x 3	2.76
HCRL-15010	0.51	1.77	7.28	M12 x 1.75	0.87	2	90°	M222 x 3	2.76
HCRL-15012	0.51	1.77	7.28	M12 x 1.75	0.87	2	90°	M222 x 3	2.76
HCRL-2006	0.51	1.97	8.46	M12 x 1.75	0.87	3	60°	M260 x 3	3.09
HCRL-2008	0.51	1.97	8.46	M12 x 1.75	0.87	3	60°	M260 x 3	3.09
HCRL-20010	0.51	1.97	8.46	M12 x 1.75	0.87	3	60°	M260 x 3	3.09
HCRL-20012	0.51	1.97	8.46	M12 x 1.75	0.87	3	60°	M260 x 3	3.09
HCRL-2506	0.59	2.17	9.65	M12 x 1.75	0.87	3	60°	M290 x 3	3.33
HCRL-2508	0.59	2.17	9.65	M12 x 1.75	0.87	3	60°	M290 x 3	3.33
HCRL-25010	0.59	2.17	9.65	M12 x 1.75	0.87	3	60°	M290 x 3	3.33
HCRL-25012	0.59	2.17	9.65	M12 x 1.75	0.87	3	60°	M290 x 3	3.33
HCRL-3006	0.59	2.17	10.24	M16 x 2.00	0.98	3	60°	M315 x 3	3.68
HCRL-3008	0.59	2.17	10.24	M16 x 2.00	0.98	3	60°	M315 x 3	3.68
HCRL-30010	0.59	2.17	10.24	M16 x 2.00	0.98	3	60°	M315 x 3	3.68
HCRL-30012	0.59	2.17	10.24	M16 x 2.00	0.98	3	60°	M315 x 3	3.68

• Refer to Figure 5 for dimensions graphic. • Imperial units of measure are used in this table (except as indicated).
 • Contact Enerpac for dimensions of custom ordered cylinders not shown above.

12.2 Dimensions, HCRL-Series (metric)

Cylinder Model Number	Collapsed Height	Extended Height	Outside Diameter	Cylinder Bore Diameter	Plunger Diameter (threaded)	Base to Advance Port	Base to Retract Port	Saddle Diameter
	A	B	D	E	F	H1	H2	J
	mm	mm	mm	mm	mm	mm	mm	mm
HCRL-506	310	460	130	100	TR 90 x 4	41	27	77
HCRL-508	377	577	130	100	TR 90 x 4	41	27	77
HCRL-5010	427	677	130	100	TR 90 x 4	41	27	77
HCRL-5012	477	777	130	100	TR 90 x 4	41	27	77
HCRL-1006	346	496	185	140	TR 120 x 6	50	36	77
HCRL-1008	421	621	185	140	TR 120 x 6	50	36	77
HCRL-10010	471	721	185	140	TR 120 x 6	50	36	77
HCRL-10012	521	821	185	140	TR 120 x 6	50	36	77
HCRL-1506	359	509	222	170	TR 150 x 6	46	32	126
HCRL-1508	434	634	222	170	TR 150 x 6	46	32	126
HCRL-15010	484	734	222	170	TR 150 x 6	46	32	126
HCRL-15012	534	834	222	170	TR 150 x 6	46	32	126
HCRL-2006	399	549	260	200	TR 170 x 6	71	49	126
HCRL-2008	469	669	260	200	TR 170 x 6	71	49	126
HCRL-20010	519	769	260	200	TR 170 x 6	71	49	126
HCRL-20012	569	869	260	200	TR 170 x 6	71	49	126
HCRL-2506	416	566	290	220	TR 190 x 6	71	49	160
HCRL-2508	491	691	290	220	TR 190 x 6	71	49	160
HCRL-25010	541	791	290	220	TR 190 x 6	71	49	160
HCRL-25012	591	891	290	220	TR 190 x 6	71	49	160
HCRL-3006	421	571	315	240	TR 210 x 6	71	49	160
HCRL-3008	496	696	315	240	TR 210 x 6	71	49	160
HCRL-30010	546	796	315	240	TR 210 x 6	71	49	160
HCRL-30012	596	896	315	240	TR 210 x 6	71	49	160

- Refer to Figure 5 for dimensions graphic. • Metric units of measure are used in this table.
- Contact Enerpac for dimensions of custom ordered cylinders not shown above.

Cylinder Model Number	Saddle Protrusion	Lock Nut Height	Base Mounting Holes					Collar Thread	
			Bolt Circle	Thread Size	Minimum Thread Depth	Number of Holes	Angle From Coupler	Thread Size	Thread Length
			U	V	Z			W	X
			mm	mm	mm	mm	mm	mm	mm
HCRL-506	15	26	105	M12 x 1.75	22	2	90°	M130 x 2	42
HCRL-508	15	26	105	M12 x 1.75	22	2	90°	M130 x 2	42
HCRL-5010	15	26	105	M12 x 1.75	22	2	90°	M130 x 2	42
HCRL-5012	15	26	105	M12 x 1.75	22	2	90°	M130 x 2	42
HCRL-1006	15	36	150	M12 x 1.75	22	2	90°	M185 x 2	57
HCRL-1008	15	36	150	M12 x 1.75	22	2	90°	M185 x 2	57
HCRL-10010	15	36	150	M12 x 1.75	22	2	90°	M185 x 2	57
HCRL-10012	15	36	150	M12 x 1.75	22	2	90°	M185 x 2	57
HCRL-1506	13	45	185	M12 x 1.75	22	2	90°	M222 x 3	70
HCRL-1508	13	45	185	M12 x 1.75	22	2	90°	M222 x 3	70
HCRL-15010	13	45	185	M12 x 1.75	22	2	90°	M222 x 3	70
HCRL-15012	13	45	185	M12 x 1.75	22	2	90°	M222 x 3	70
HCRL-2006	13	50	215	M12 x 1.75	22	3	60°	M260 x 3	79
HCRL-2008	13	50	215	M12 x 1.75	22	3	60°	M260 x 3	79
HCRL-20010	13	50	215	M12 x 1.75	22	3	60°	M260 x 3	79
HCRL-20012	13	50	215	M12 x 1.75	22	3	60°	M260 x 3	79
HCRL-2506	15	55	245	M12 x 1.75	22	3	60°	M290 x 3	85
HCRL-2508	15	55	245	M12 x 1.75	22	3	60°	M290 x 3	85
HCRL-25010	15	55	245	M12 x 1.75	22	3	60°	M290 x 3	85
HCRL-25012	15	55	245	M12 x 1.75	22	3	60°	M290 x 3	85
HCRL-3006	15	55	260	M16 x 2.00	25	3	60°	M315 x 3	94
HCRL-3008	15	55	260	M16 x 2.00	25	3	60°	M315 x 3	94
HCRL-30010	15	55	260	M16 x 2.00	25	3	60°	M315 x 3	94
HCRL-30012	15	55	260	M16 x 2.00	25	3	60°	M315 x 3	94

- Refer to Figure 5 for dimensions graphic. • Metric units of measure are used in this table.
- Contact Enerpac for dimensions of custom ordered cylinders not shown above.

12.3 Specifications, HCRL-Series

Cylinder Model Number	Stroke		Cylinder Class	Maximum Capacity			Effective Area		Oil Capacity		Weight	
	in	mm		US Ton	Tonnes	kN	in ²	cm ²	in ³	cm ³	lb	Kg
HCRL-506	5.91	150	50	53.8	48.8	478.5	10.60	68.4	62.55	1025	65	30
HCRL-508	7.87	200	50	53.8	48.8	478.5	10.60	68.4	83.42	1367	79	36
HCRL-5010	9.84	250	50	53.8	48.8	478.5	10.60	68.4	104.29	1709	88	40
HCRL-5012	11.81	300	50	53.8	48.8	478.5	10.60	68.4	125.16	2051	98	45
HCRL-1006	5.91	150	100	111.2	100.9	989.6	21.91	141.4	129.41	2121	141	64
HCRL-1008	7.87	200	100	111.2	100.9	989.6	21.91	141.4	172.54	2827	170	77
HCRL-10010	9.84	250	100	111.2	100.9	989.6	21.91	141.4	215.68	3534	188	85
HCRL-10012	11.81	300	100	111.2	100.9	989.6	21.91	141.4	258.81	4241	207	94
HCRL-1506	5.91	150	150	168.6	153.0	1500.9	33.23	214.4	196.26	3216	213	97
HCRL-1508	7.87	200	150	168.6	153.0	1500.9	33.23	214.4	261.69	4288	256	116
HCRL-15010	9.84	250	150	168.6	153.0	1500.9	33.23	214.4	327.11	5360	284	129
HCRL-15012	11.81	300	150	168.6	153.0	1500.9	33.23	214.4	392.50	6432	312	142
HCRL-2006	5.91	150	200	225.0	204.1	2001.2	44.31	285.9	261.62	4288	318	145
HCRL-2008	7.87	200	200	225.0	204.1	2001.2	44.31	285.9	348.87	5718	370	168
HCRL-20010	9.84	250	200	225.0	204.1	2001.2	44.31	285.9	436.06	7147	406	184
HCRL-20012	11.81	300	200	225.0	204.1	2001.2	44.31	285.9	523.31	8577	440	200
HCRL-2506	5.91	150	250	276.8	251.1	2463.0	54.54	351.9	322.08	5278	419	190
HCRL-2508	7.87	200	250	276.8	251.1	2463.0	54.54	351.9	429.35	7037	492	224
HCRL-25010	9.84	250	250	276.8	251.1	2463.0	54.54	351.9	536.67	8796	538	244
HCRL-25012	11.81	300	250	276.8	251.1	2463.0	54.54	351.9	644.15	10556	584	265
HCRL-3006	5.91	150	300	333.6	302.6	2968.8	65.74	424.1	388.23	6362	505	230
HCRL-3008	7.87	200	300	333.6	302.6	2968.8	65.74	424.1	517.60	8482	592	269
HCRL-30010	9.84	250	300	333.6	302.6	2968.8	65.74	424.1	647.03	10603	647	294
HCRL-30012	11.81	300	300	333.6	302.6	2968.8	65.74	424.1	776.41	12723	702	319

• Contact Enerpac for specifications of custom ordered cylinders not shown above.

Notes:

