

# IPM-Series, Internal Mechanical Pullers **ENERPAC**

▼ Shown: **IPM3**



## IPM Series

Maximum Reach:

**1.77 - 3.11 inches**

Spread Range:

**0.98 - 3.94 inches**



### IMPORTANT!

Always wear Safety Goggles and Gloves while using pullers.

- Remove bearings or other shaft-mounted parts where no spindle support is available
- Slide hammer allows for application of safe, high-impact force
- Includes two sets of jaws for internal and external pulling applications

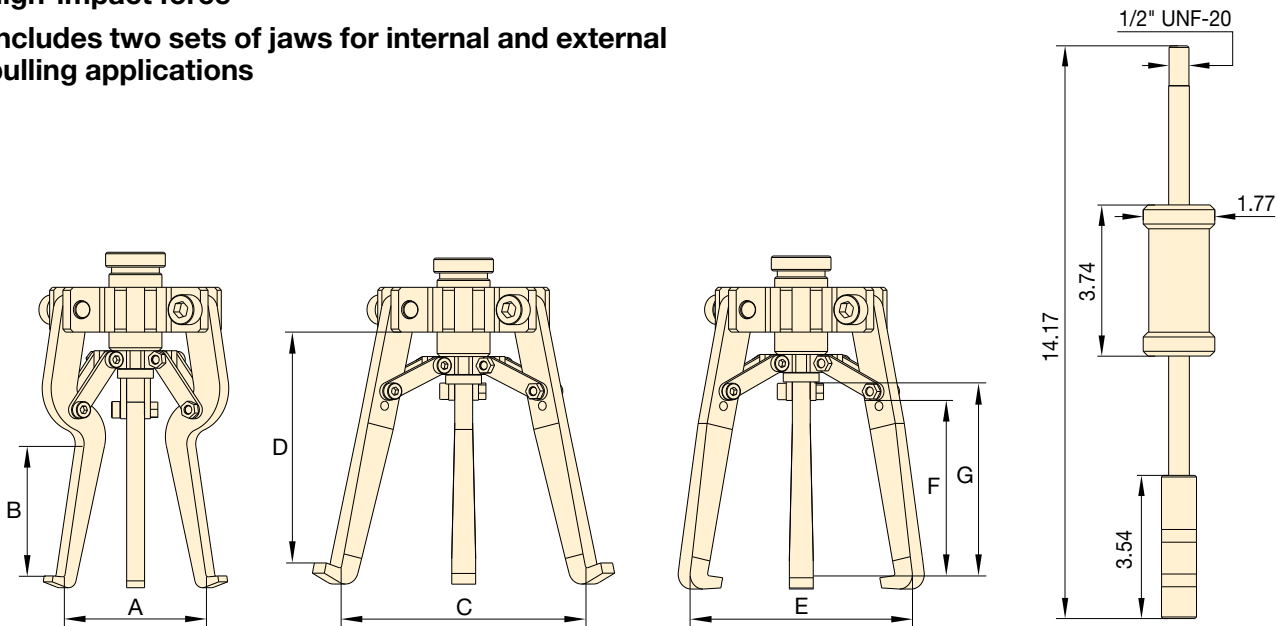

Slide Hammer Dimensions (in)

### ▼ DIMENSIONAL CHART

Model Number	Internal Jaw Dimensions (in)		Standard Jaw Dimensions (in)							Weight (lbs)	
			Internal Configuration			External Configuration					
	Spread Diameter		Maximum Reach	Spread Diameter		Maximum Reach	Spread Diameter		Maximum Reach		
	(min)	(max)	B	(min)	(max)	D	(min)	(max)	F	G	
<b>IPM3</b>	0.98	2.36	1.77	2.36	3.94	3.11	0.59	2.95	2.16	2.75	4.60