

To Protect Your Warranty, Use Only ENERPAC Hydraulic Oil.

Enerpac recommends that all kit components be installed to insure optimum performance of the repaired pump.

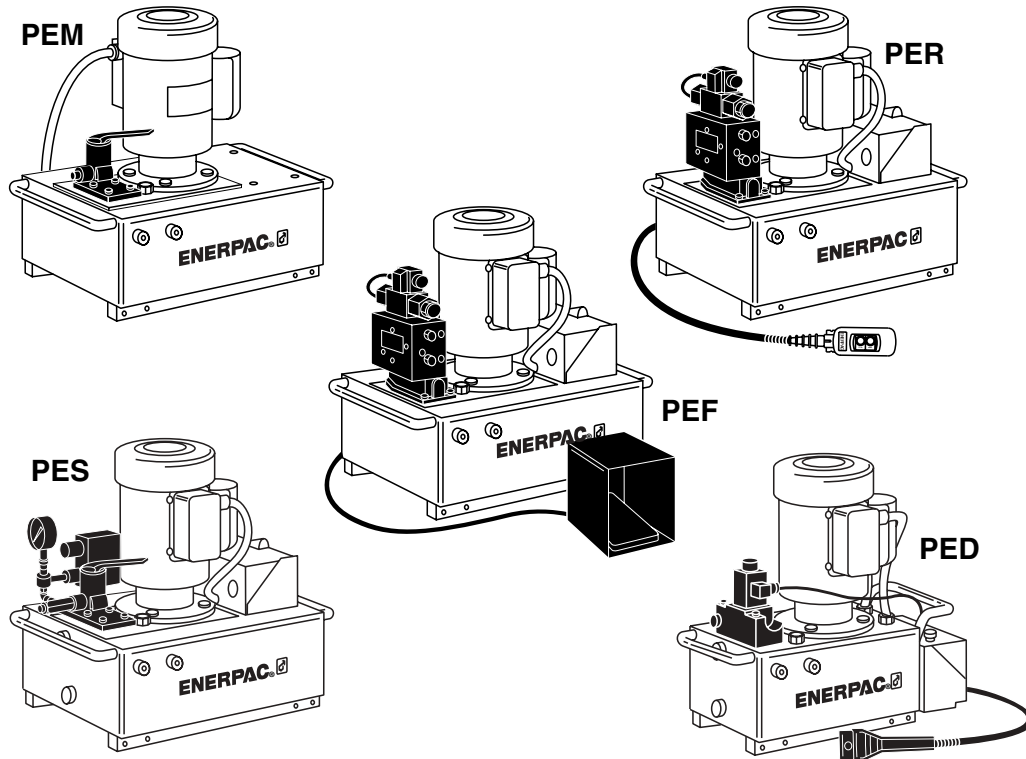

CONTENTS

Pump Section

Pump and Reservoir Assembly 2
 Basic Pump Assembly 3-4
 By-Pass Valve Assembly 4-5

Valve Section

Dump Valve Assembly 6
 3-way Electric Solenoid Valve Assembly 7-9
 4-way Electric Solenoid Valve Assembly 10-12
 2-way Manual Valve 12
 3- and 4-way Manual Valves 13-14
 Pendant Assembly 15
 Footswitch 16

Electrical Section

Electrical Enclosure, 110/220 Volt, 1 Phase 17-20
 Electrical Enclosure, 230/460 Volt, 3 Phase 20-24

Options Section

Pressure Switch Assembly 25
 Roll Bar Assembly 26
 Heat Exchanger Assembly 27
 Oil Filter Assembly 28
 Special Filter Assembly 29

Wiring Section

Motor Terminal Box Wiring 30-31
 Pump Wiring Diagrams 32-39

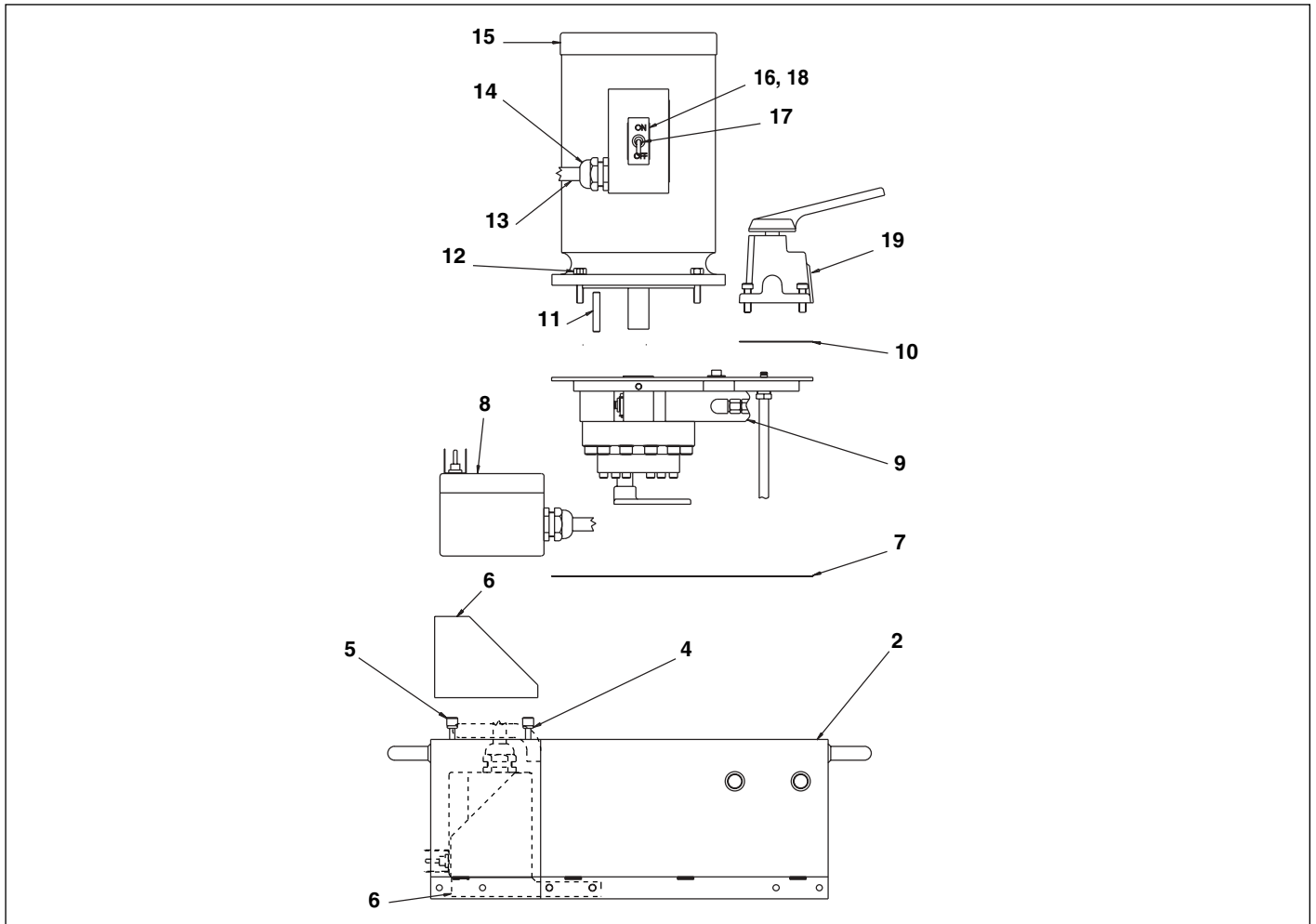

Figure 1, Pump and Reservoir Assembly

Repair Parts List for Figure 1

Item	Part Number	Qty.	Description	Item	Part Number	Qty.	Description	
2	DA11509025SR	1	2 Gallon (8 liter) Reservoir	12	CBB1023046-1B	4	Screw	
	DA11510025SR	1	5 Gallon (20 liter) Reservoir (shown)		13	DA4090450SR	1	Power Cord (PEM Models)
	DA11511025SR	1	10 Gallon (40 liter) Reservoir		14	DA3643007	1	Strain Relief (PEM Models)
3	C187018	3	Reservoir Magnet (not shown)		15	DA3440259SR	1	Motor (1 1/2 HP, 115/230 V, 1 PH., 60 Hz)
4	★ B1001503	4	O-Ring			DA5012259SR	1	Motor (1 1/2 HP, 115/230 V, 1 PH., 50 Hz)
5	CSS4729D	4	Bolt			DA3391259SR	1	Motor (1 1/2 HP, 230/460 V, 3PH.)
6	CV747098	1	Bracket (2 Gal.)			DA3392259SR	1	Motor (3 HP, 230/460 V, 3 PH.)
	BSS5481D	1	Bracket (5 & 10 Gal.)			DA3392259SR	1	Motor (3 HP, 380 V, 50 Hz)
7	★ DA12114037	1	Reservoir Gasket			DA5011259	1	Motor (3 HP, 575 V, 3 PH)
8	Electrical Enclosure		See Electrical Section, pages			DA5013259	1	Motor (1 1/2 HP, 575 V, 3 PH)
9	Pump Assembly		See Basic Pump Assembly, pages 4-5			16	DA4110372	1
10	★ F786167	1	Valve Gasket		17	DA4030372	1	Switch (PEM Models)
11	DC890251	1	Key		18	DA4251037	1	Gasket (PEM Models)
					19	Directional Valve		See Valve Section, pp. 7-19

★ Indicates Items Included in and Available Only as Part of Repair Kit PE304050K.
 ★ Indicates Items Included in and Available Only as Part of Repair Kit PE304050KV (Viton).
 ★ Indicates Items Included in and Available Only as Part of Repair Kit PE304050KE (EPR).

***NOTES**

- Item 14 - Torque to 6.6-7.4 ft-lb [9-10 Nm]
- Item 15 - Torque to 15.5-17 ft-lb [21-23 Nm]
Use Loctite 271 on threads
- Item 23 - Torque to 6.6-7.4 ft-lb [9-10 Nm]

- Item 28 - Torque to 66-77 in-lb [7,8-8,7 Nm]
- Item 40 - Torque to 14-22 ft-lb [18-30 Nm]
Use Loctite 545 for pipe fittings
- Item 45 - Torque to 42-47 in-lb [4,7-5,3 Nm]

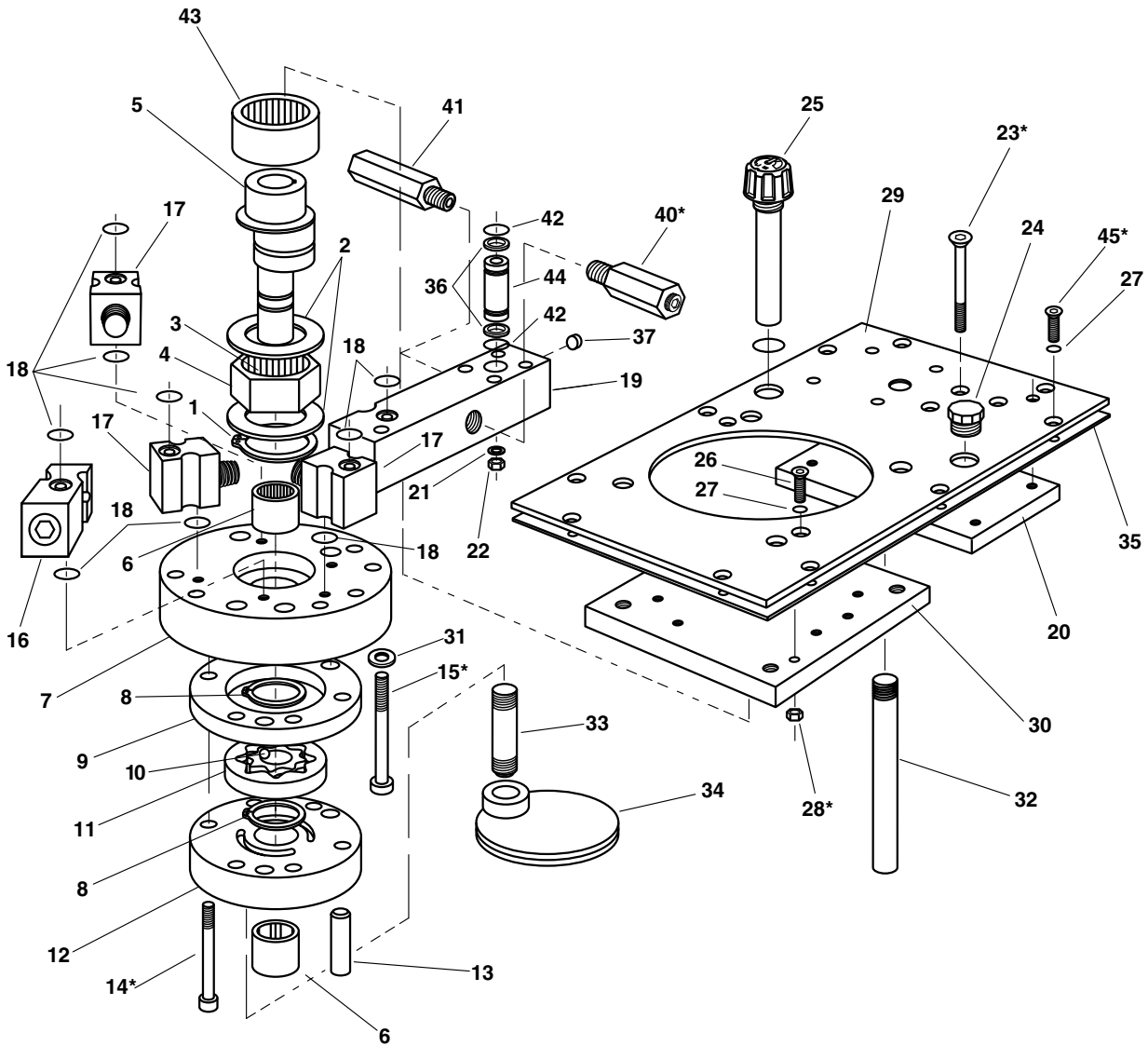

Figure 2, Basic Pump Assembly

Repair Parts List for Figure 2

Item	Part Number	Qty.	Description	Item	Part Number	Qty.	Description
1	★ CCA1035044-1A	1	Retaining Ring	25	DA7454223	1	Breather/Level Gauge (2 & 5 gal. reservoir)
2	BSS4725D	2	Thrust Washer		DA7455223	1	Breather/Level Gauge (10 gal. reservoir)
3	BSS4599D	1	Needle Bearing	26	CBA523028-1B	2	Screw
4	DA3837350SR	1	Hex Cam & Bearing Assy.	27	★ B1003503	12	O-Ring
5	DA3824537SR	1	Eccentric	28	DC1469120	2	Nut
6	CW251107	2	Needle Bearing	29	DA12032101	1	Top Plate
7	DC3580101SR	1	Upper Plate with Bearing	30	DA3832101SR	1	High Pressure Plate with Bearing
8	★ DA1985044	2	Retaining Ring	31	CAE1080108-1A	10	Washer
9	BSS5484D	1	Middle Plate	32	DA4104431	1	Return Pipe (2 & 5 Gal.)
10	★ B1005016	2	3/16" Ball		DA4105431	1	Return Pipe (10 Gal.)
11	BSS5117DSR	1	Gerotor Set	33	DA4106431	1	Intake Pipe (2 & 5 Gallon, 8 & 20 liter)
12	BSS5371DSR	1	Bottom Plate with Bearing		DA4103431	1	Intake Pipe (10 Gallon, 40 liter)
13	CAA1029061-2A	3	Dowel Pin	34	CV838950SR	1	Intake Filter
14	CBA631028-1A	6	Screw	35	★ BSS4637D	1	Gasket
15	BSS5974D	10	Screw	36	★ BSS0368D	2	Back-up Ring
16	DC633900SR	1	By-Pass Valve Assy.	37	A1006245	1	Plug
17	DA11976950SR	3	Piston Block Assy. (30 Series)	40	DA5999900SR	1	Relief Valve
	DA3833900SR	3	Piston Block Assy. (40, 50 Series)	41	DA5999900SR	1	Relief Valve
18	★ B1013803	9	O-Ring	42	B1007503	2	O-Ring
19	CS396096	1	Connector Block	43	DA3831155	1	Bearing
20	BSS5898D	1	Support Plate	44	DA9261096	1	Connector
21	CCE1060108-6A	4	Lock Washer	45	CBA519028-1B	10	Screw
22	CBB1060120-1D	4	Nut				
23	CBA637028-1B	4	Screw				
24	A8071006	1	Plug				

★ Indicates Items Included in and Available Only as Part of Repair Kit PE304050K.

★ Indicates Items Included in and Available Only as Part of Repair Kit PE304050KV (Viton).

★ Indicates Items Included in and Available Only as Part of Repair Kit PE304050KE (EPR).

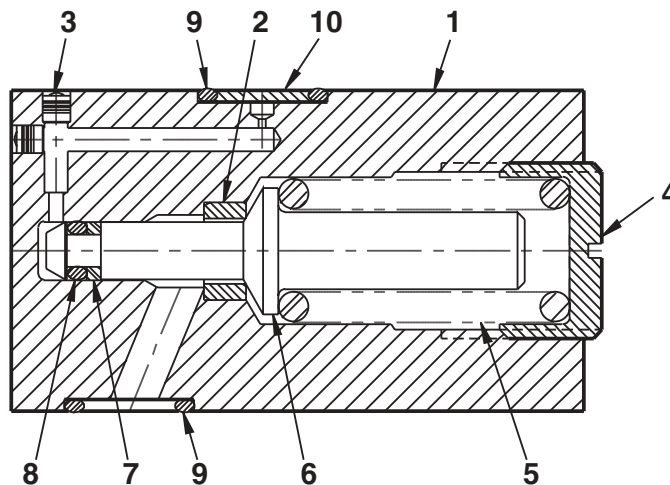

Figure 2A, Bypass Valve Assembly (Late Models, Date Code "B")

Repair Parts List for Figure 2A (Late Models, Date Code "B")

Item	Part Number	Qty.	Description	Item	Part Number	Qty.	Description
1	DC617190	1	Valve Body	6	DC1117051	1	Piston
2	Not Serviceable	1	Seat (Pressed in)	7	★	1	B/U Washer
3	F100009-57	2	Expander Plug	8	★	1	O-Ring
4	DC625006	1	End Plug	9	★	2	O-Ring
5	★	1	Spring	10	★	1	Filter Disc

★ Indicates Items Included in and Available Only as Part of Repair Kit DC633900K.

Note:

Item #2 and #8 are staked at the factory and can not be disassembled without damaging the threads. A new piston and nut are included in the repair kit and must be used when servicing the By-pass Valve.

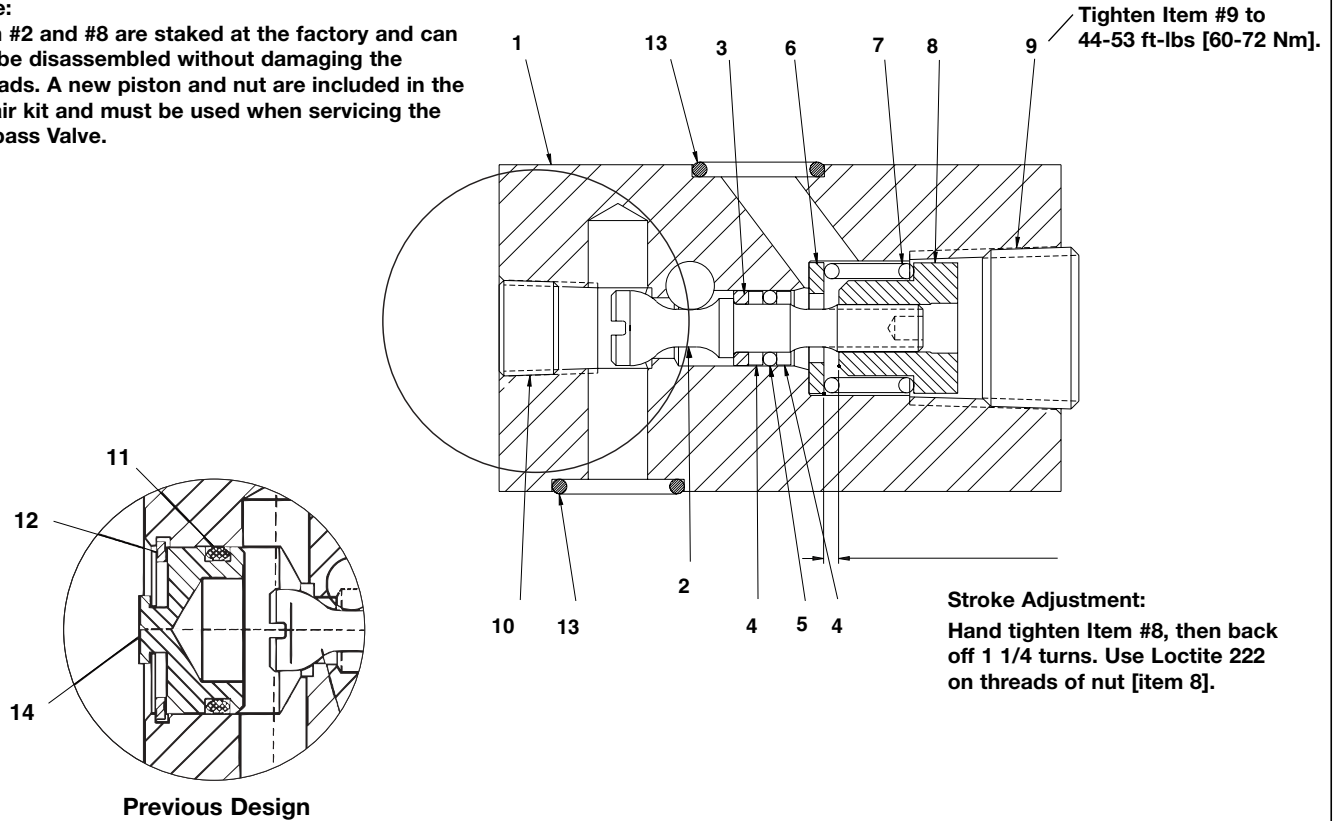

Figure 2B, Bypass Valve Assembly (Early Models, Date Code "A")

Repair Parts List for Figure 2B (Early Models, Date Code "A")

Item	Part Number	Qty.	Description	Item	Part Number	Qty.	Description
1	DC633900SR	1	Complete Bypass Valve (BUNA)	6	CAE1070108-1A	1	Washer
	DC1410900SR	1	Complete Bypass Valve (Viton)	7	BSS5528D	1	Spring
	DC2361900SR	1	Complete Bypass Valve (EPR)	8	★	1	Nut
2	★	1	Piston	9	A8071006	1	Plug
3	★	1	Stop Ring	10	A1007245	1	Plug
4	★	2	Back-Up Washer	11	★	1	O-Ring
5	★	1	O-Ring	12	★	1	Retaining Ring
				13	★	2	O-Ring
				14	BSS5578D	1	Cap

★ Indicates Items Included in and Available Only as Part of Repair Kit CY359900K

NOTES

Item 3 - Apply Loctite 222 to threads, torque to 25-30 ft. lbs.

Item 15 - Torque to 25-30 ft-lbs. [5,0-6,0 Nm].

Apply a bead of RTV self-forming gasket.

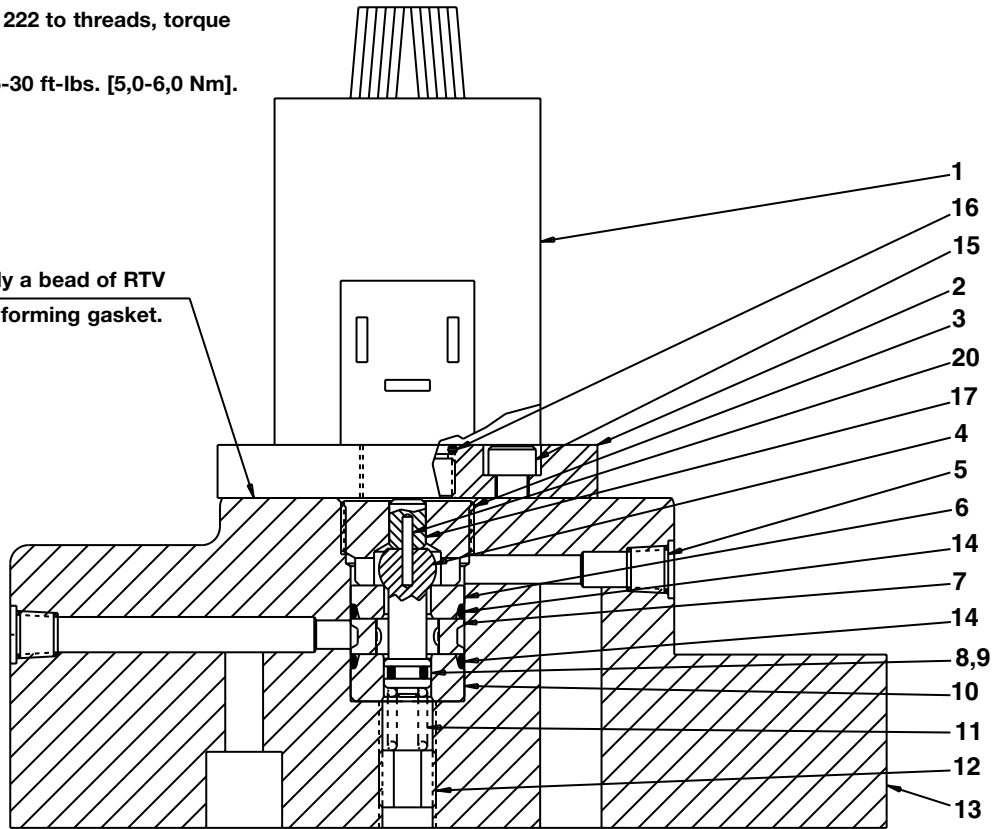

**Figure 3, DA3624900SR Dump Valve Assembly
DA9539900SR Dump Valve Assembly (EPR)**

Repair Parts List for Figure 3

Item	Part Number	Qty.	Description	Item	Part Number	Qty.	Description
1	DA3703720SR	1	Solenoid	12	A8071027	1	Hollow Set Screw
2	DA3586101	1	Adaptor Plate	13	DA3577190	1	Valve Block
3	DA3700039	1	Bushing	14	★ B1016803	2	O-Ring
4	DA3587440SR	1	Poppet (Includes Items 6, 8, 9, 17 & 20)	15	B1323028	4	Socket Head Cap Screw
5	A1006245	2	Plug	16	★ B1220503	1	O-Ring
6	DA5311290	1	Seat (Included in Item 4)	17	DA3588186	1	Spacer (Included in Item 4)
7	DA3698290	1	Seat Spacer	18	B1351028	3	Socket Head Cap Screw
8	★ B1002503	1	O-Ring (Included in Item 4)	19	B1361028	2	Socket Head Cap Screw
9	★ CM279044	1	Glyde Ring (Included in Item 4)	20	DA4789059	1	Dowel Pin (Included in Item 4)
10	DA3697039	1	Bushing	21	R515245-2	1	Pipe Plug (not shown)
11	★ CM278110	1	Spring	22	★ F786167	1	Valve Gasket (See page 2, item 10)

★ Indicates Items Included in and Available Only as Part of Repair Kit DA3624900K

★ Indicates Items Included in and Available Only as Part of Repair Kit DA3624900KE (EPR).

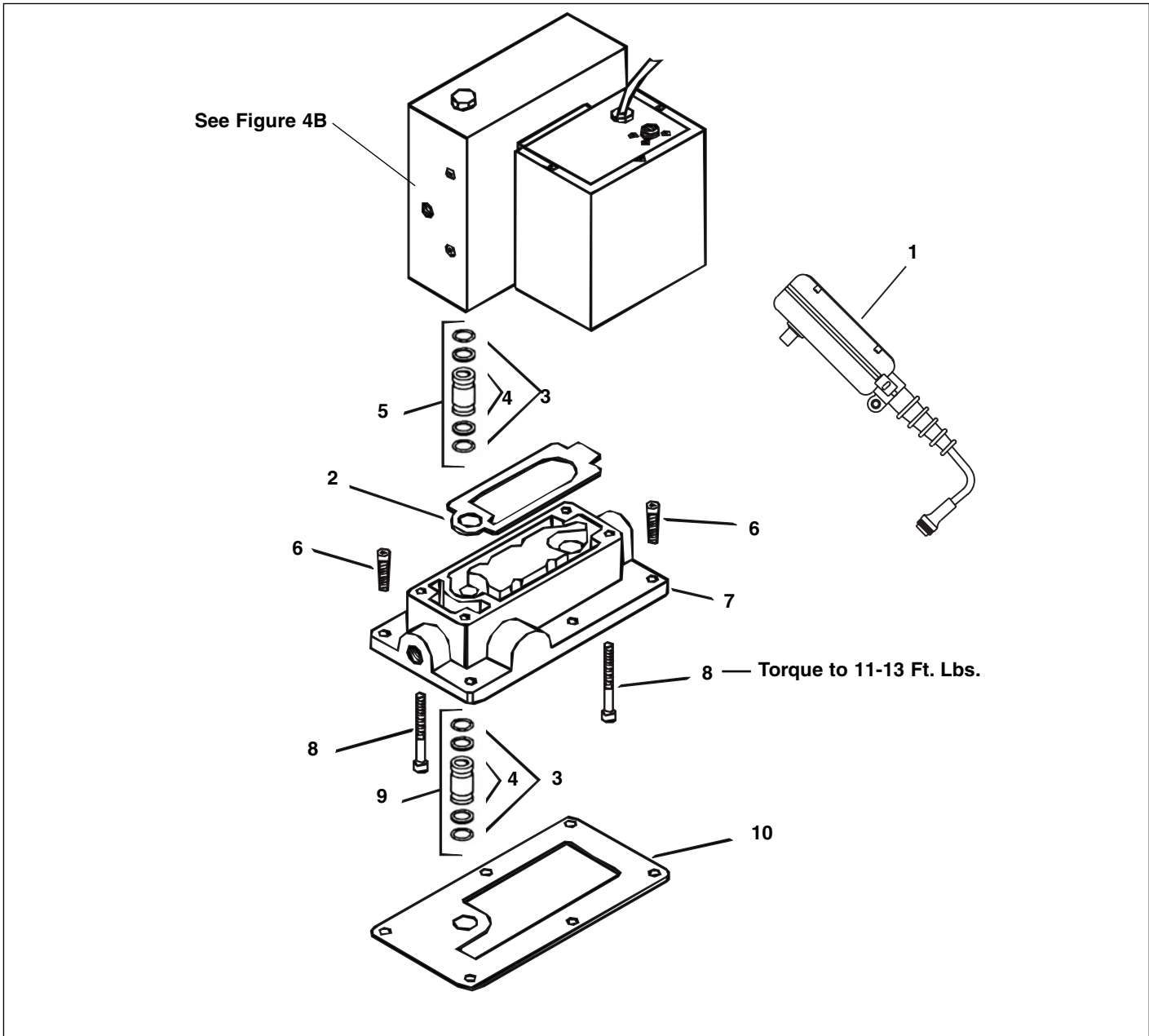

Figure 4A, VS3-24 Valve Assembly

Repair Parts List for Figure 4A							
Item	Part Number	Qty.	Description	Item	Part Number	Qty.	Description
1	IC324	1	Pendant Control	6	B1351028	6	Socket Head Cap Screw
2	★ CM56167	1	Gasket	7	F127038	1	Base
3	★ B1007503	4	O-Ring	8	B1017028	4	Socket Head Cap Screw
4	★ B1012564	4	Back-up Washer	9	DA9261096	1	Connector
5	DA973950SR	1	Connector Assembly	10	★ F786167	1	Gasket

★ Indicates Items Included In And Available Only As Part Of Repair Kit VS3-24K

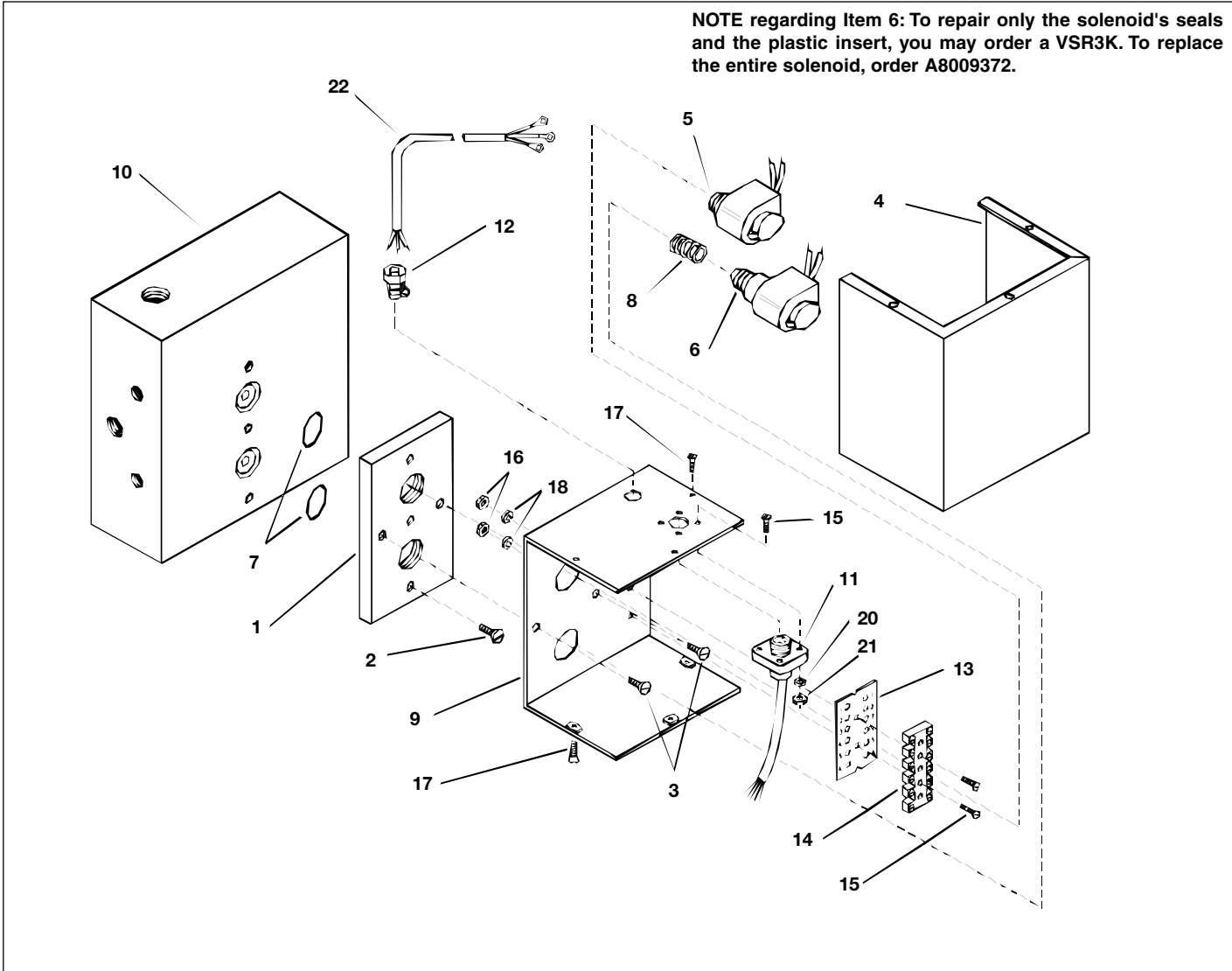

Figure 4B, VS3-24 Valve Assembly (Electrical)

Repair Parts List for Figure 4B							
Item	Part Number	Qty.	Description	Item	Part Number	Qty.	Description
1	M694101	1	Mounting Plate	11	F1980-4SR	1	Receptacle
2	DA4726028	3	Cap Screw	12	DA3642007	1	Strain Relief
3	P181138	2	Screw	13	C690026	1	ID Strip
4	M560345	1	Solenoid Box Top	14	C700270	1	Terminal Strip
5	DA3827372	1	24 Volt Solenoid (B)	15	BL20225	6	Bolt
6	DA3826372	1	24 Volt Solenoid (A)	16	BL20226	6	Nut
7	★ B1014503	2	O-Ring	17	K533028	6	Machine Screw
8	★ M89110	1	Spring	18	F594066	4	Washer
9	DA4020345	1	Solenoid Control Box	20	B1082066	4	Lockwasher
10	CL105950SR	1	Valve Block Assembly (See Figure 4C)	21	B1009121	4	Nut
				22	DA3740450SR	1	Cord

★ Indicates Items Included in and Available Only as Part of Repair Kit VS3-24K

NOTE:

Main Check Seat is press fit and is not serviceable.

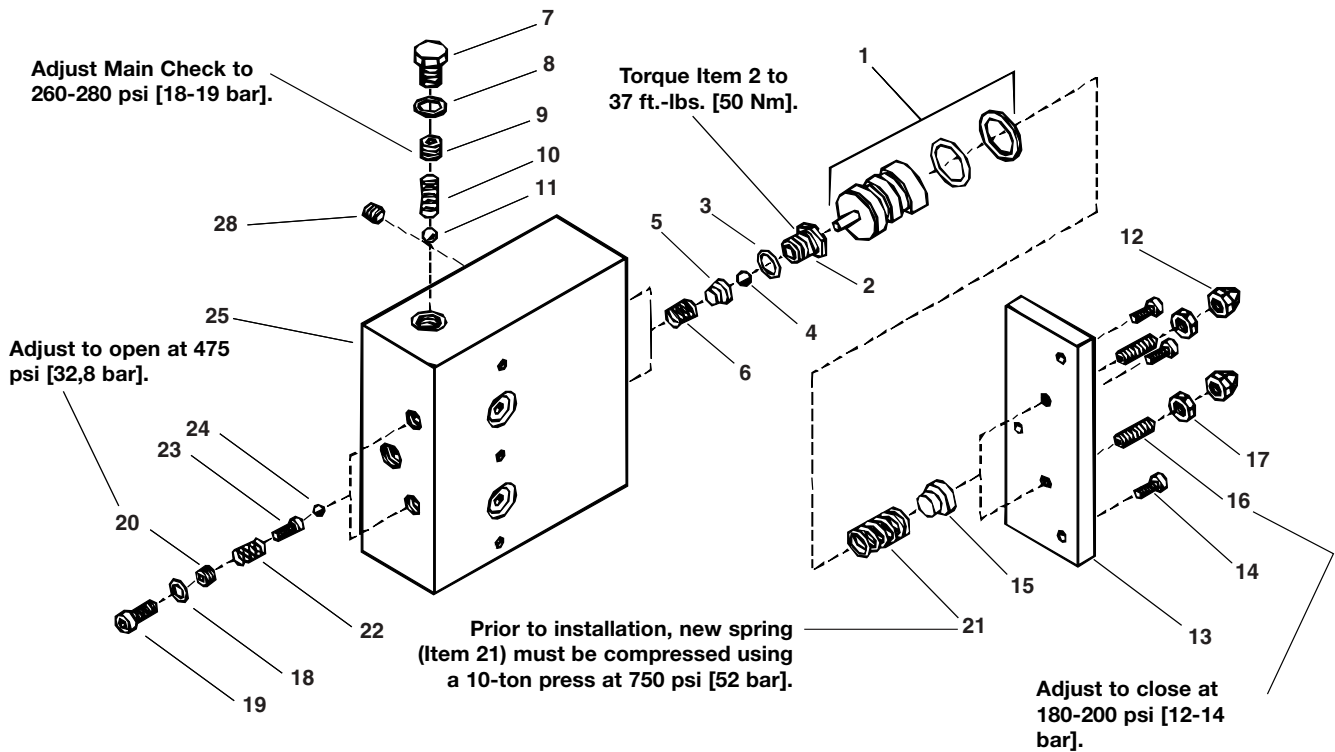

Figure 4C, VS3-24 Valve Block Assembly

Repair Parts List for Figure 4C

Item	Part Number	Qty.	Description	Item	Part Number	Qty.	Description
1	CL106950W	2	Piston Ass'y.	14	B1007028	3	Capscrew
2	★ M31290	2	Seat	15	CH43950W	2	Spacer
3	★ P182167	2	Gasket	16	Y157028	2	Set Screw
4	★ B1007016	2	1/4" Ball	17	F378123	2	3/8"-24 UNF Jam Nut
5	L843186	2	Spacer	18	★ S3037	2	Gasket
6	L848110	2	Spring	19	B1002028	2	Cap Screw
7	AJ100061	1	Plug	20	M203028	2	Adjusting Screw
8	★ B159167	1	Gasket	21	★ BL10967	2	Spring
9	BL20219	1	Adjusting Screw	22	★ Y75110	2	Spring
10	★ C614177	1	Spring	23	L429013	2	Ball Guide
11	★ B1010016	1	11/32" Ball	24	★ B1003016	2	1/8" Ball
12	L342055	2	Acorn Nut 3/8"-24 UNF	25	M693190SR	1	Valve Body
13	M22098	1	Cover	26	A1006245	2	Plug 1/6"-27 NPTF

★ Indicates Item Included In And Available Only As Part Of Repair Kit VS3-24K

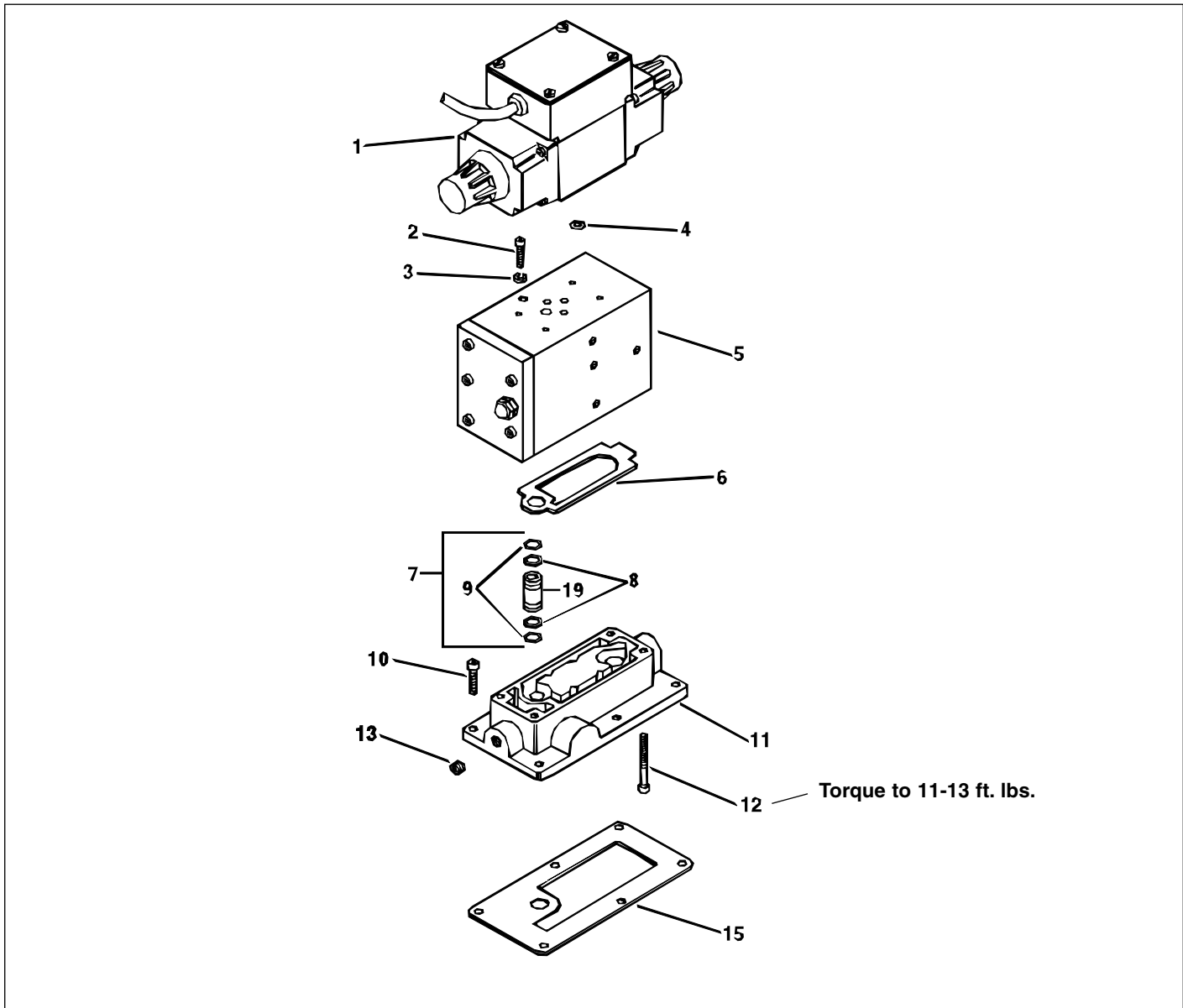

Figure 5A, VS4-24 Valve Assembly

Repair Parts List for Figure 5A							
Item	Part Number	Qty.	Description	Item	Part Number	Qty.	Description
1	DA3791900SR	1	Solenoid Assy's. (24 Volt)	9	★ B1012203	2	O-Ring
2	B1332028	4	Cap Screw	10	B1351028	6	Cap Screw
3	M231108	4	Lock Washer	11	F132038	1	Adapter
4	★ B1904203	4	O-Ring	12	B1017028	4	Cap Screw
5	CL99950W	1	Valve Block Assy's.	13	DA6192245	1	Plug
6	★ CM56167	1	Gasket	15	★ F786167	1	Gasket
7	DA973950SR	1	Connector Assy's. (Valve to Adapter)	16	IC424	1	Remote Pendant (not shown)
8	★ B1012564	2	Back-up Washer	19	C162096	1	Connector

★ Indicates Items Included in and Available Only as Part of Repair Kit VS4-24K1

Torque settings for ball seats:

Lower seat (item 22) - 25 ft.-lbs. [34 Nm]

Upper seats (item 20 & 21) - 37 ft.-lbs. [50 Nm]

IMPORTANT: When installing new spring, Item 27, compress to 750 psi [51,8 bar] (1680 lbs of force) on a 10-Ton ENERPAC press prior to assembly.

Pilot Pressure - Adjust to 850-900 psi [59-62]

Torque to 10-12 ft.-lbs. [14-16 Nm]

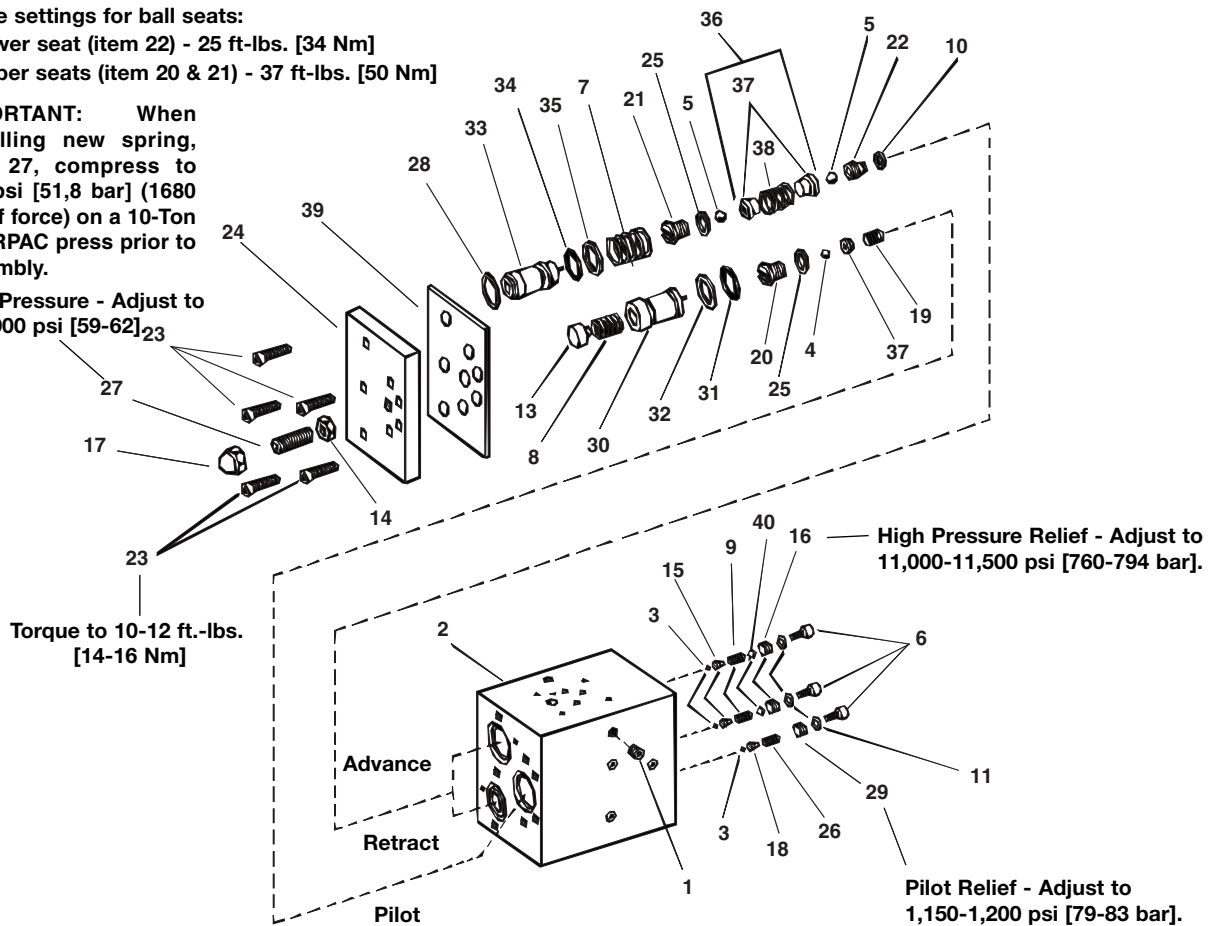

Figure 5B, VS4-24 Valve Block Assembly

Repair Parts List for Figure 5B

Item	Part Number	Qty.	Description	Item	Part Number	Qty.	Description
1	★ A1006245	5	Plug 1/16"-27 NPTF	22	★ CW182290	2	Seat
2	CL938950W	1	Valve Block Assy's.	23	B1009028	7	Cap Screw
3	★ B1003016	3	1/8" Ball	24	M502098	1	Cover
4	★ B1007016	1	1/4" Ball	25	★ P182167	3	Gasket
5	★ B1010016	4	11/32" Ball	26	★ Y75110	1	Spring
6	B1342028	3	Screw	27	Y158028	1	Adjusting Screw
7	★ BL10952	2	Spring	28	★ B1216518	2	Seal Ring
8	★ BL10967	1	Spring	29	Y948028	1	Adjusting Screw
9	★ BL10968	2	Spring	30	DA983950SR	1	Piston Assy's.
10	★ BL30156	2	Gasket	31	★ B1214203	1	O-Ring
11	★ C846037	3	Gasket	32	★ B1214564	1	Back-up Washer
13	CH43950W	1	Spacer	33	DA982950SR	2	Piston Assy's.
14	F378123	1	Nut	34	★ B1214203	2	Piston Assy's.
15	★ K1013	2	Ball Guide	35	★ B1214564	2	O-Ring
16	K877028	2	Adjusting Screw	36	CL104950W	2	Spring & Spacer Assy's.
17	L342055	1	Acorn Nut	37	L843186	5	Spacer
18	★ L429013	1	Ball Guide	38	★ CW98110	2	Spring
19	★ L848110	1	Spring	39	★ CM172167	1	Gasket
20	★ M31290	1	Seat	40	CF634006	2	Slug
21	★ CW181290	2	Seat				

★ Indicates Items Included in and Available Only as Part of Repair Kit VS.-24K1

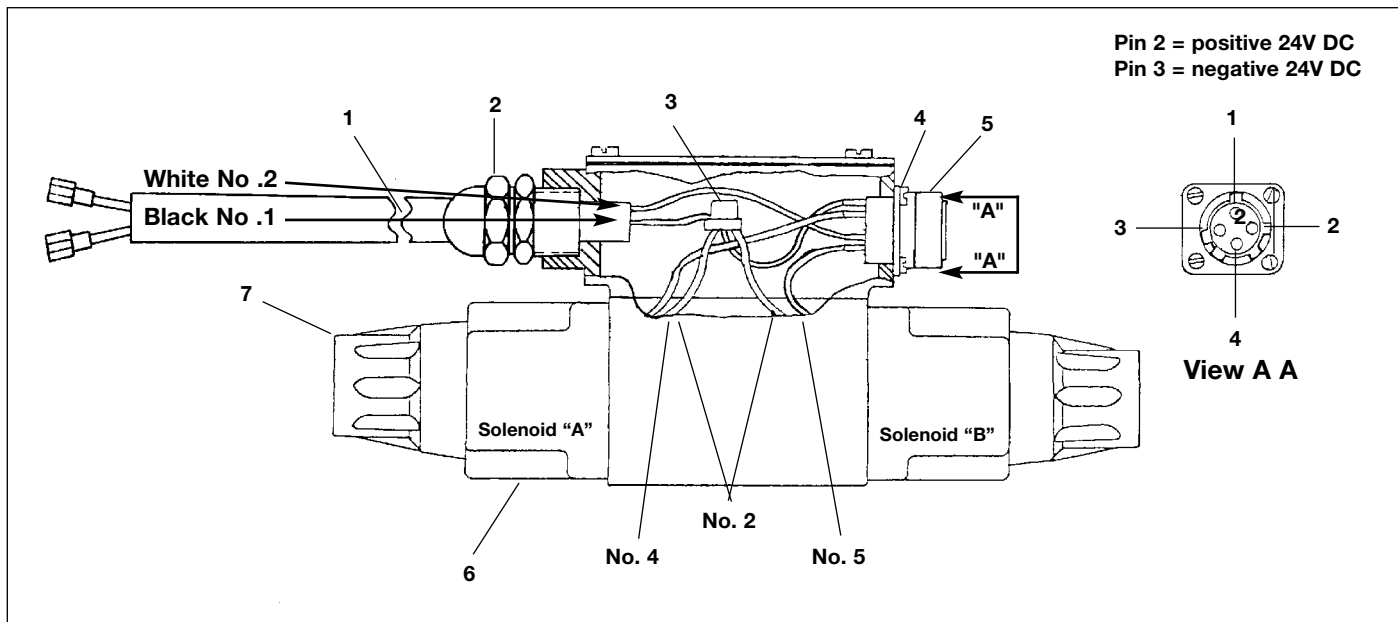

Figure 5C, Solenoid Assembly

Repair Parts List for Figure 5C

Item	Part Number	Qty.	Description	Item	Part Number	Qty.	Description
1	DA3740450SR	1	Electric Cord	5	F1980-4SR	1	Socket Connector
2	DA5752007	1	Strain Relief	6	DA6372720	2	24 Volt Coil
3	BL20187	1	Connector	7	DA6373021	2	Coil Nut
4	DA4041028	4	Self-Tapping Screw	8	DA3793001	1	Terminal Box

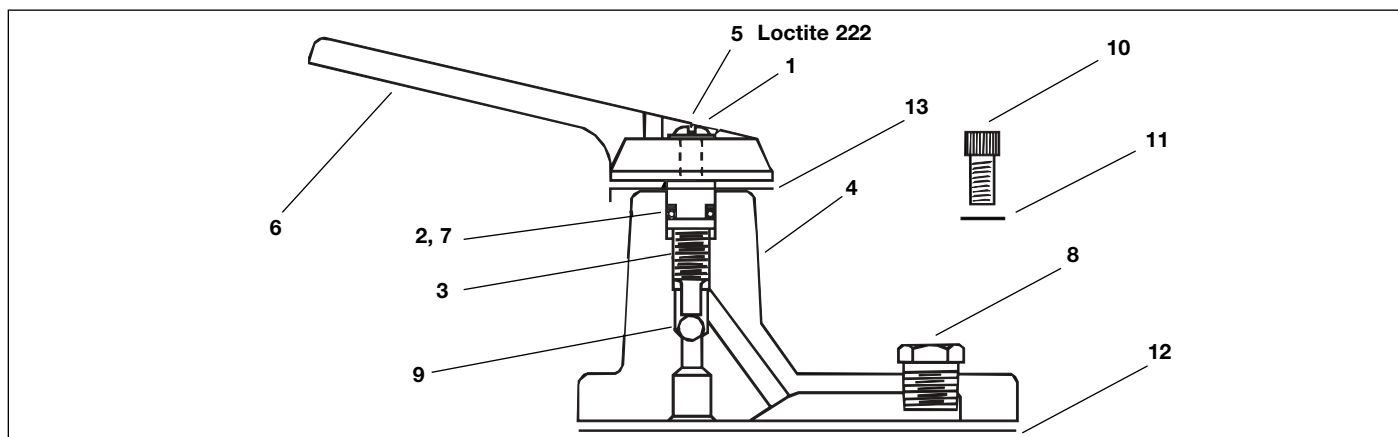

Figure 6, VM-2 Valve Assembly

Repair Parts List for Figure 6

Item	Part Number	Qty.	Description	Item	Part Number	Qty.	Description
1	B1086108	1	Washer	7	★B1111203	1	O-Ring
2	★B1111564	1	Back-up Washer	8	R515245-2	1	Pipe Plug
3	C790010SR	1	Valve Stem	9	★B1009016	1	5/16" Ball
4	-----	1	Valve Body (Not Sold Separately Order Complete VM-2)	10	B1351028	6	Screw
5	C302128	1	Screw	11	★C846037	6	Copper Gasket
6	Y402070	1	Valve Handle	12	★F786167	1	Valve Gasket
				13	C756160	1	Retainer

★ Indicates Items Included in and Available Only as Part of Repair Kit VM2K1

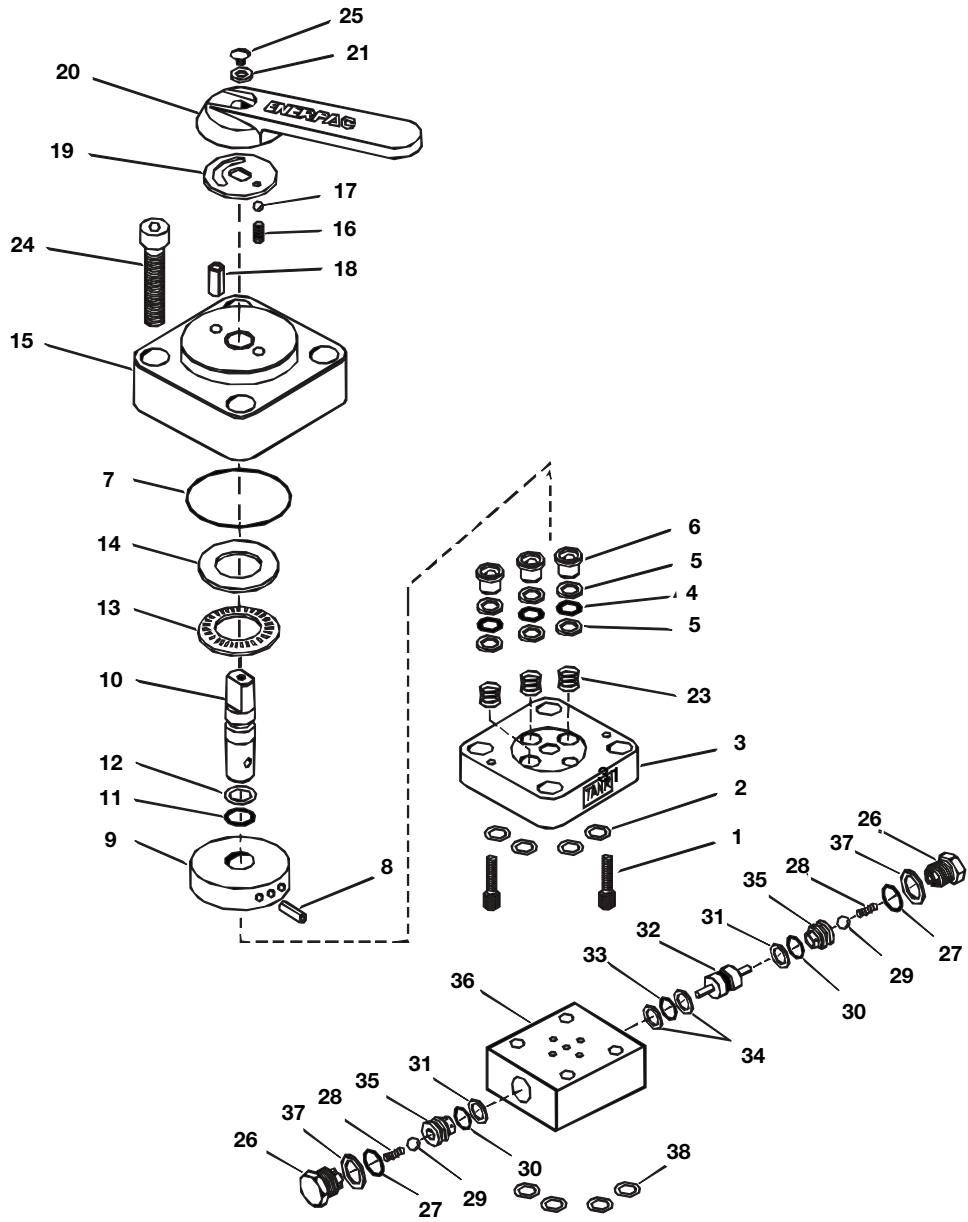

Figure 7A, 3-Way & 4-Way Manual Valve Assembly

Repair Parts List for Figure 7A							
Item	Part Number	Qty.	Description	Item	Part Number	Qty.	Description
1	B1326028	2	Cap Screw	22	B1051057	1	Pin (not shown)
2	★B1111803	4	O-Ring	23	★CB28110	3	Spring
3	CH539190	1	Body	24	B1389028	4	Capscrew (VM-3 & VM-4 Only)
4	★B1006503	3	O-Ring		B1401028	4	Capscrew (VM-3L & VM-4L Only)
5	★B1011564	6	Back-up Washer	25	★A8076048	1	Screw
6	★DA9560041	3	Shear Seal	26	CR356013	2	Plug
7	★B1269503	1	O-Ring	27	★B1116803	2	O-Ring
8	★B1109057	1	Roll Pin	28	★CJ656110	2	Spring
9	CH538950SR	1	Disc Ass'y. (VM-3 Only)	29	★B1008016	2	9/32" Ball
	CH542950SR	1	Disc Ass'y. (VM-3L, VM-4, VM-4L)	30	★B1011503	2	O-Ring
10	CH536104	1	Shaft	31	★B1113564	2	Back-up Washer
11	★B1007503	1	O-Ring	32	CK598900SR	1	Piston Ass'y. (VM-3L only)
12	★B1012564	1	Back-up Washer		Y128900W	1	Piston Ass'y. (VM-4L only)
13	CB328281	1	Needle Bearing	33	★B1009503	1	O-Ring
14	CB327101	1	Bearing Plate	34	★B1111564	2	Back-up Washer
15	CB324001	1	Valve Cap	35	Y126290	2	Seat
16	★A8039110	1	Spring	36	CL889950SR	1	Body (VM-3L only)
17	★B1006016	1	7/32" Ball		CL888950SR	1	Body (VM-4L only)
18	★B1126057	1	Spring Pin	37	★CR355167	2	Gasket
19	A8005071	1	Detent Disc	38	★B1111803	4	O-Ring (VM3L and VM4L only)
20	Y325070	1	Valve Handle				
21	★B1086108	1	Washer				

★ Indicates Items Included in and Available Only as Part of Repair Kit VM4K3

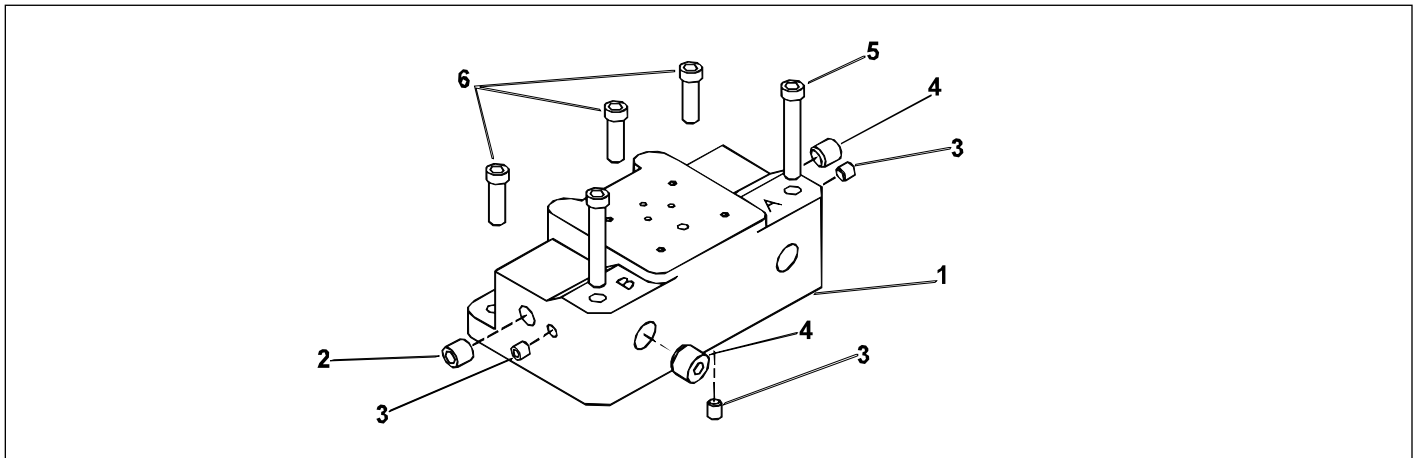

Figure 7B, Manual Valve Mounting Block Assembly

Repair Parts List for Figure 7B							
Item	Part Number	Qty.	Description	Item	Part Number	Qty.	Description
1	CB303038	1	Adaptor Block	5	B1359028	2	Capscrew
2	DA6192245	1	Pipe Plug	6	B1351028	3	Capscrew
3	R515245-2	2	Pipe Plug				
4	A1006245	1	Pipe Plug (VM-3, VM-3L use 2)				

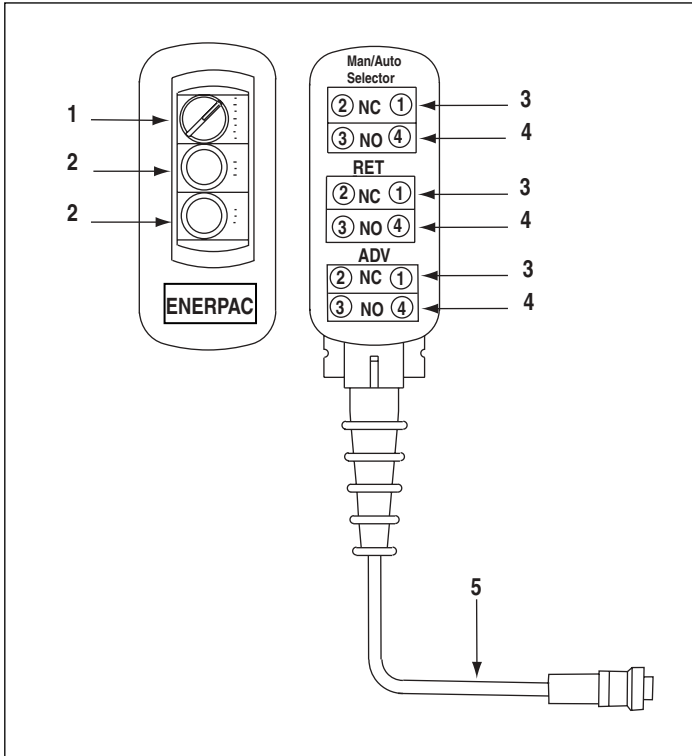

Figure 8A, Pendant Assembly

Repair Parts List for Figure 8A			
Item	Part Number	Qty.	Description
1	DC2065369	1	2-Position Switch
2	DC2062369	2	Boot
3	DC2064369	3	N. C. Contact Blocks
4	DC2063369	3	N. O. Contact
5	DA3788900SR	1	Cord Assembly

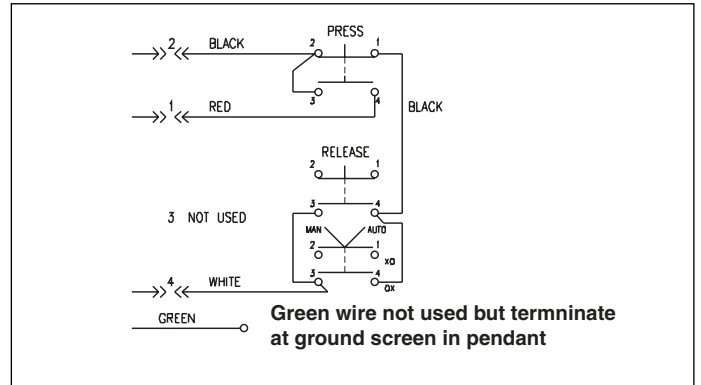

Figure 8AA, 3-Button Pendant Schematic

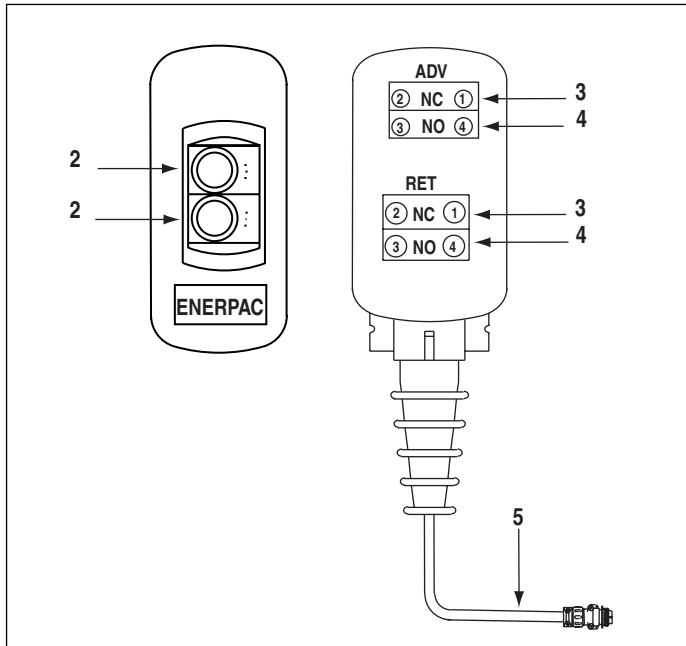

Figure 8B, Pendant Assembly

Repair Parts List for Figure 8B			
Item	Part Number	Qty.	Description
2	DC2062369	2	Boot
3	DC2064369	2	N. C. Contact Blocks
4	DC2063369	2	N. O. Contact
5	DA3788900SR	1	Cord Assembly

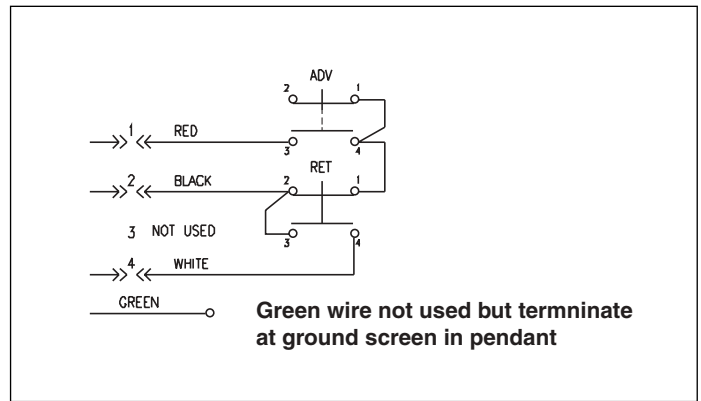

Figure 8BB2-Button Pendant Schematic

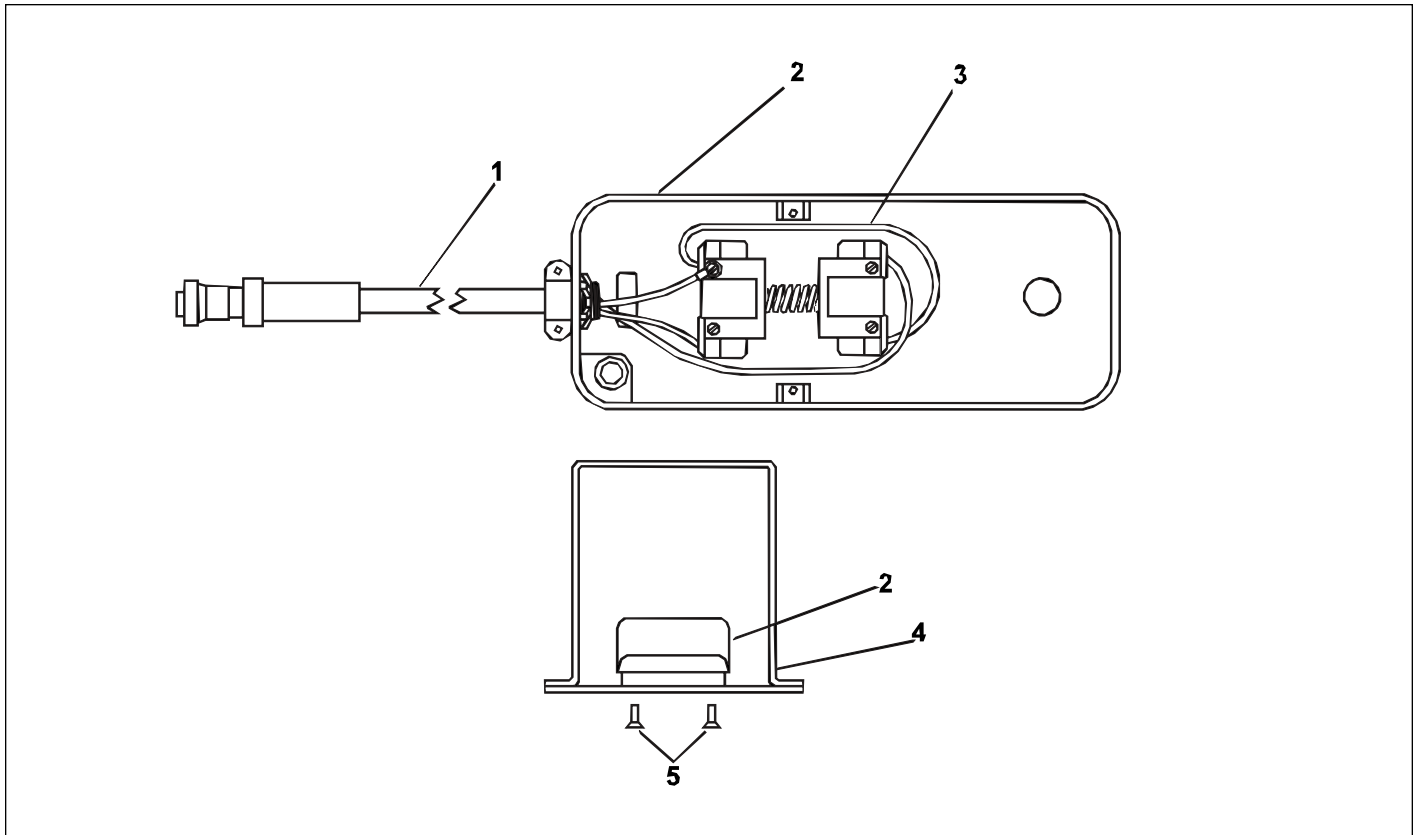
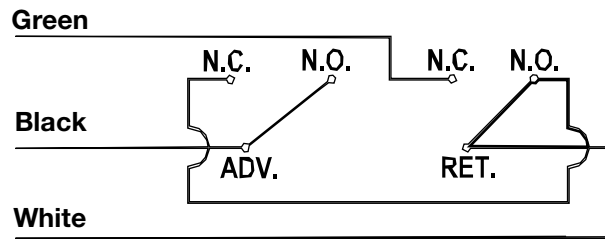

Figure 9, Foot Switch Assembly

Note: Terminal designations are for wiring only and do not reflect the true functions of the switch.



Wiring Diagram

Repair Parts List for Figure 9

Item	Part Number	Qty.	Description	Item	Part Number	Qty.	Description
1	CH278450SR	1	Cord Ass'y.	4	CA683900SR	1	Guard Ass'y.
2	CH754372	1	Foot Switch	5	M922028	2	Screw
3	Std. Wire	1	16 Ga. 6.0" Long				

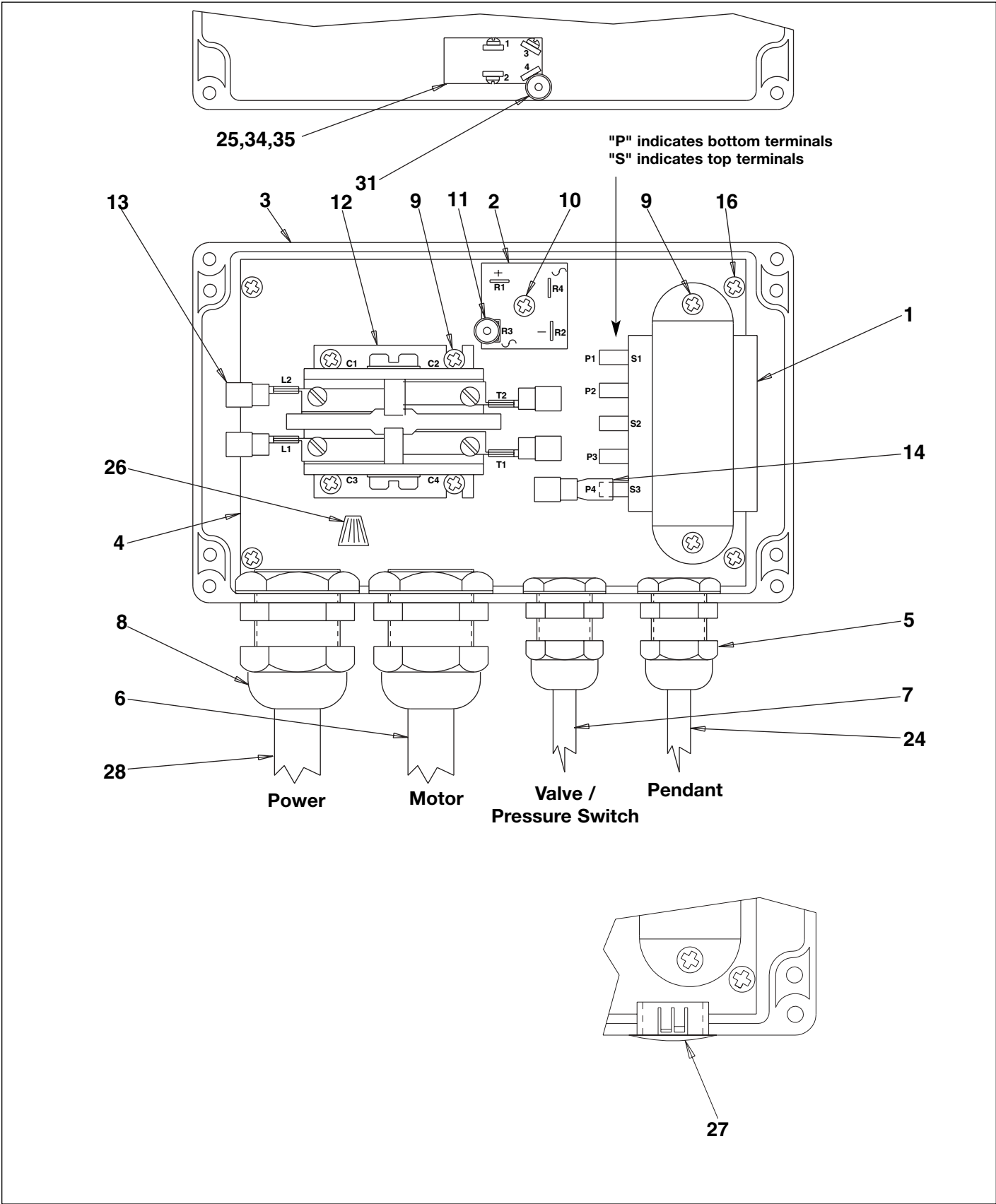

Figure 10A, Electrical Enclosure, 110/220 Volt, 1 Phase

Repair Parts List for Figure 10A, Electrical Enclosure, 110/220 Volt, 1 Phase

Item	Part Number	Qty.	Description	Item	Part Number	Qty.	Description
1	DA3567380	1	Transformer	17	DA3929900SR	3	Wire Ass'y. (See Charts 10A-1, 10A-2, 10A-3)
2	DA3578380	1	Rectifier (VS-4 & Dump Models Only)	18	DA3936900SR	2	Wire Ass'y. (See Chart 10A-1)
3	DA3569401	1	Enclosure	19	DA3930900SR	2	Wire Ass'y. (See Charts 10A-1, 10A-2)
4	DC1223101	1	Mounting Plate	20	DA3931900SR	1	Wire Ass'y. (See Charts 10A-1, 10A-2, 10A-3)
5	DA3642007	1	Strain Relief	24	DA3991900SR	1	Pendant (Dump Model Only)
6	DA3742450SR	1	Motor Cord	25	DA4030372	1	Switch
7	DA3740450SR	1	Valve Cord	26	G536055	1	Wire Nut
	CU943900SR	1	Valve Cord (Dump Model Only)	27	DA3644009	1	Hole Plug
8	DA3643007	1	Strain Relief	28	DA4090450SR	1	Power Cord
9	DA3641028	6	#6-32 x .250" lg. Self-Tapping Screw	29	DA4091900SR	1	Wire Ass'y. (See Chart 10A-3)
10	DA3639028	1	#6-32 x .620" lg. Self-Tapping Screw	30	DA4092900SR	1	Wire Ass'y. (See Chart 10A-3)
11	E1001104	1	.250" Female Push-on Connector (22-18 Ga. Wire)	31	E1001018	2	#6 Ring Connector (12-10 Ga. Wire)
12	DA3568980	1	Relay (Pressure Switch & Dump Model)	32	DA4096900SR	1	Wire Ass'y. (See Charts 10A-1, 10A-2)
13	E1001110	4	.250" Female Push-on Connector (12-10 Ga. Wire)	33	DA4095900SR	1	Wire Ass'y. (See Charts 10A-1, 10A-2)
14	E1001103	1	.187" Female Push-on Connector (22-18 Ga. Wire)	34	DA4110372	1	Switch Guard
16	CAE0205028-3A	4	M3 x 8M Lg. Pan Head Screw	35	DA4251037	1	Gasket

Wiring code charts on following pages for 110/220 Volt, 1 Phase Models.

Wiring schematics for all pumps found at the back of this booklet.

Chart 10A-1 "Dump Pump" Wiring Code Chart

Item No.	Part Number	Description	Wire Color	From		To	
				Item #	Term#	Item #	Term. #
6	DA3742450	Motor Cord	White			12	T1
			Black			12	T2
			Green			28	Item No. 26
28	DA4090450	Power Cord	White			25	2
			Black			25	1
			Green			6	Item No. 26
7	CU943900	Valve Cord	White			2	R1
			Black			2	R2
17	DA3929900	Wire	Black	1	S1	12	C1
	DA3929900	Wire	Black	1	P4	12	L2
	DA3929900	Wire	Black	1	P2	12	L2
18	★ DA3936900	Wire	Black	2	R3	12	C2
	DA3936900	Wire	Black	2	R4	12	C3
19	DA3930900	Wire	White	1	P1	12	L1
	DA3630900	Wire	White	1	P3	12	L1
20	★ DA3931900	Wire	Black	1	P3	1	P2
24	★★ DA3991900	Pendant Cord	White	1	S3		
			Black	1	P3	12	C4
32	DA4096900	Wire	White	25	4	12	L1
33	DA4095900	Wire	Black	25	3	12	L2

Chart 10A-2 "Pressure Switch Pump" Wiring Code Chart

Item No.	Part Number	Description	Wire Color	From		To	
				Item #	Term#	Item #	Term. #
6	DA3742450	Motor Cord	White			12	T1
			Black			12	T2
			Green			28	Item No. 26
28	DA4090450	Power Cord	White			25	2
			Black			25	1
			Green			6	Item No. 26
7	DA3740450	Valve Cord	White			1	S3
			Black			22	C3
17	DA3929900	Wire	Black	1	S1	12	C1
	DA3929900	Wire	Black	1	P1	12	L2
	★ DA3929900	Wire	Black	1	P3	12	L2
19	DA3930900	Wire	White	1	P4	12	L1
	★ DA3630900	Wire	White	1	P2	12	L1
20	DA3931900	Wire	Black	1	P2	1	P3
32	★★ DA4096900	Wire	White	25	4	12	L1
33	DA4095900	Wire	Black	25	3	12	L2

1) ★ - 110 Volt Only

2) ★★ - 230 Volt Only

3) Route all wires to prevent interference with relay operation and contact with unused transformer terminal.

Chart 10A-3 "Elec. Valves VS3 & VS4 Pump" Wiring Code Chart

Item No.	Part Number	Description	Wire Color	From		To	
				Item #	Term#	Item #	Term. #
6	DA3742.450	Motor Cord	White			25	4
			Black			25	3
			Green			28	Item No. 26
28	DA4090.450	Power Cord	White			25	2
			Black			25	1
			Green			6	Item No. 26
		VS - 424	White			2	R1
		Valve Cord	Black			2	R2
		VS - 324	White			2	R3
		Valve Cord	Black			2	R4
17	DA3929.900	Wire	Black	1	S1	2	R3
	DA3929.900	Wire	Black	1	S3	2	R4
20	★★ DA3931.900	Wire	Black	1	P2	1	P3
29	★ DA4091.900	Wire	White	25	4	1	P2,P4
30	★ DA4092.900	Wire	Black	25	3	1	P1,P3
29	★★ DA4091.900	Wire	White	25	4	1	P4
30	★★ DA4092.900	Wire	Black	25	3	1	P1

- 1) ★ - 110 Volt Only
 2) ★★ - 230 Volt Only
 3) Route all wires to prevent interference with relay operation and contact with unused transformer terminal.

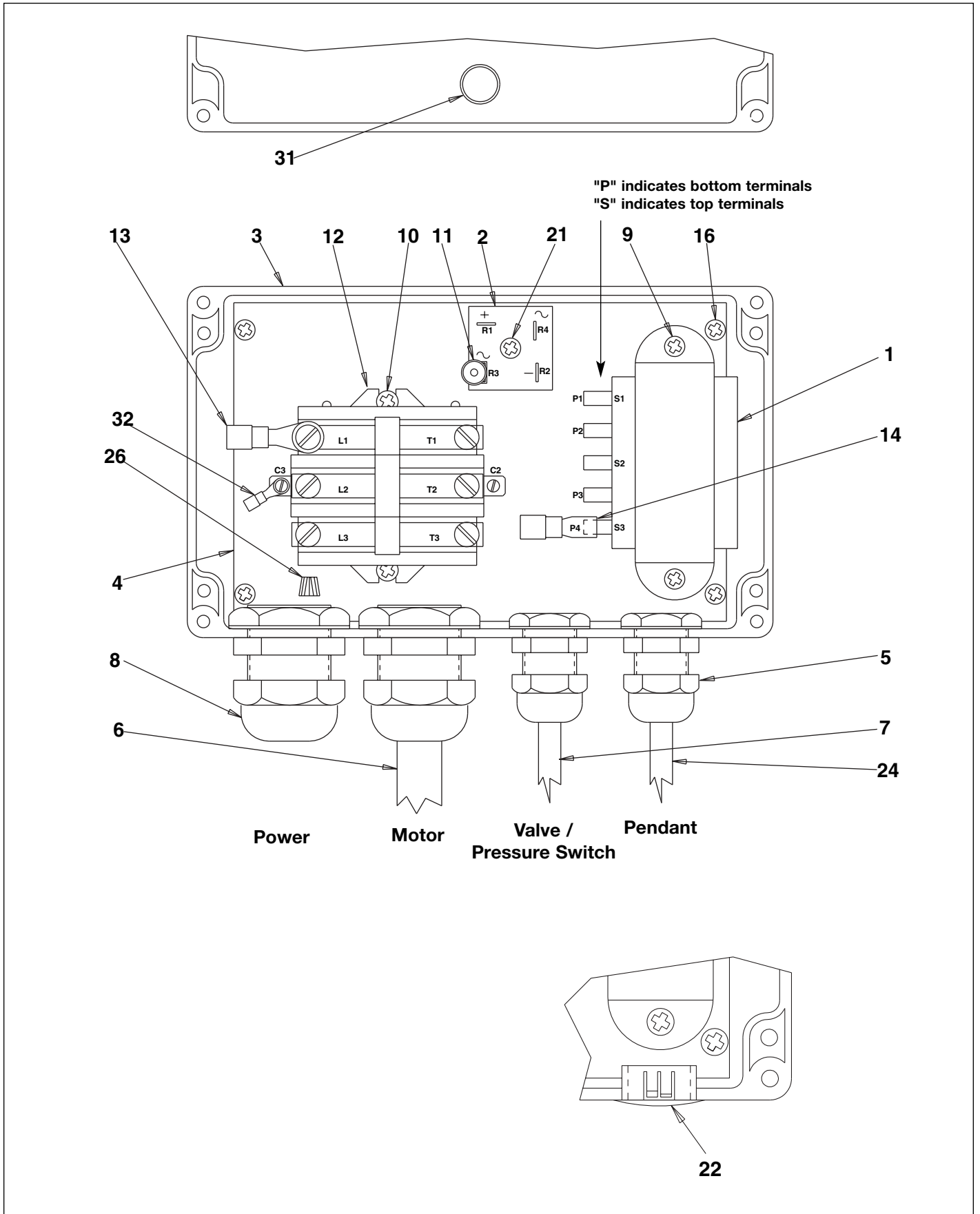

Figure 10B, Electrical Enclosure, 230/460 Volt, 3 Phase

Figure 10B, Electrical Enclosure, 230/460/575 Volt, 3 Phase Parts List

Item	Part Number	Qty.	Description	Item	Part Number	Qty.	Description
1	DA3567380	1	Transformer (230 Volt, 3 Phase Model)	14	E1001103	4	.187" Female Push-on Connector (22-18 Ga. Wire)
	DA3575380	1	Transformer (460 Volt, 3 Phase Model)	15	DA3935900SR	1	Wire Ass'y. (See Chart)
	DA5049380	1	Transformer (575 Volt, 3 Phase Model)	16	CAE0205028-319	4	M3 x 8M Lg. Pan Head Screw
2	DA3578380	1	Rectifier (VS-4 and Dump Models Only)	17	DA3934900SR	2	Wire Ass'y. (See Charts 10B-1, 10B-2)
3	DA3569401SR	1	Enclosure	18	DA3936900SR	2	Wire Ass'y. (See Chart 10B-1)
4	DC1223101	1	Mounting Plate	19	DA3933900SR	2	Wire Ass'y. (See Chart 10B-3)
5	DA3642007	2	Strain Relief	20	DA3931900SR	1	Wire Ass'y. (See Charts 10B-1, 10B-2, 10B-3)
6	DA3743450SR	1	Motor Cord	21	DA3640028	1	#6-32 x .620" Lg. Self-Tapping Screw
7	DA3740450SR	1	Valve Cord	22	DA3644009	1	Hole Plug
	CU943900SR	1	Valve Cord (Dump Valve Model Only)	24	DA3991900SR	1	Pendant (Dump Model Only)
8	DA3643007	2	Strain Relief	26	G536005	1	Wire Nut
9	DA3639028	2	#6-32 x .250" Lg. Self-Tapping Screw	27	DA4120900SR	1	Wire Ass'y. (See Chart 10B-3)
10	DA3641028	2	#6-32 x 1.00" Lg. Self-Tapping Screw	28	DA4121900SR	1	Wire Ass'y. (See Chart 10B-3)
11	E1001104	1	.250" Female Push-on Connector (22-18 Ga. Wire)	31	DA3645009	1	Hole Plug
	DA4842380	2	Terminal Adaptor (575 Volt, 3 Phase Models)	32	E1001004	1	Connector (460 Volt/575 Volt, 3 Phase Models)
12	DA3589980	1	Relay (Pressure Switch & Dump Models)				
13	E1001012	3	#8 Ring Connector (16-14 Ga. Wire)				

Wiring code charts on following pages for 230/460 Volt, 3 Phase Models
 Wiring schematics for all pumps found at the back of this booklet.

Chart 10B-1 "Dump Pump 230/460/575-3Ø" Wiring Code Chart

Item No.	Part Number	Description	Wire Color	From		To	
				Item #	Term#	Item #	Term. #
6	DA3743450	Motor Cord	White			12	T1
			Black			12	T2
			Red			12	T3
			Green			26	See Note 1
7	CU943900	Valve Cord	White			2	R1
	★★		Black			2	R2
15	★★ DA3935900	Wire	White	1	P4	12	L1
17	DA3934900	Wire	Black	1	S1	12	C1
	DA3934900	Wire	Black	1	P1	12	L2
18	DA3936900	Wire	Black	2	R4	12	C2
	DA3936900	Wire	Black	2	R3	12	C1
20	DA3931900	Wire	Black	1	P3	1	P2
24	★ DA3991900	Pendant Cord	White			1	S3
			Black			12	C2

Chart 10B-2 "Pressure Switch 230/460/575-3Ø" Wiring Code Chart

Item No.	Part Number	Description	Wire Color	From		To	
				Item #	Term#	Item #	Term. #
6	DA3743450	Motor Cord	White			12	T1
			Black			12	T2
			Red			12	T3
			Green			26	See Note 1
7	DA3740450	P/S Cord	White			1	S3
			Black			12	C2
15	DA3935900	Wire	White	1	P4	12	L1
17	DA3934900	Wire	Black	1	S1	12	C1
	DA3934900	Wire	Black	1	P1	12	L2
20	★ DA3931900	Wire	Black	1	P3	1	P2

- 1) Item 26, wire nut, to be placed on end of wire
- 2) Wires to be tied together with item 26, wire nut. Wiring will be completed by customer.
- 3) Route all wires to prevent interference with relay operation and contact with unused transformer terminal.
- 4) ★ - Used on 230 Volt Only
- 5) ★★ - Rotate plug socket 90° tight

Chart 10B-2 "VS3 & VS4 230/460/575-3Ø" Wiring Code Chart

Item No.	Part Number	Description	Wire Color	From		To	
				Item #	Term#	Item #	Term. #
6	DA3743450	Motor Cord	White			28	See Note 2
			Black			27	See Note 2
			Red			26	See Note 1
			Green			26	See Note 1
		VS - 424	White			2	R1
		Valve Cord	Black			2	R2
		VS - 324	White			2	R3
		Valve Cord	Black			2	R4
19	DA3933900	Wire	Black	1	S1	2	R3
	DA3933900	Wire	Black	1	S3	2	R4
20	DA3931900	Wire	Black	1	P3	1	P2
27	DA4120900	Wire	Black	1	P1	6	See Note 2
28	★ DA4121900	Wire	White	1	P4	6	See Note 2

- 1) Item 26, wire nut, to be placed on end of wire
- 2) Wires to be tied together with item 26, wire nut. Wiring will be completed by customer.
- 3) Route all wires to prevent interference with relay operation and contact with unused transformer terminal.
- 4) ★ - Used on 230 Volt Only

Mounting for VM2 shown, mounting for VM3 and VM4 is mirror image.

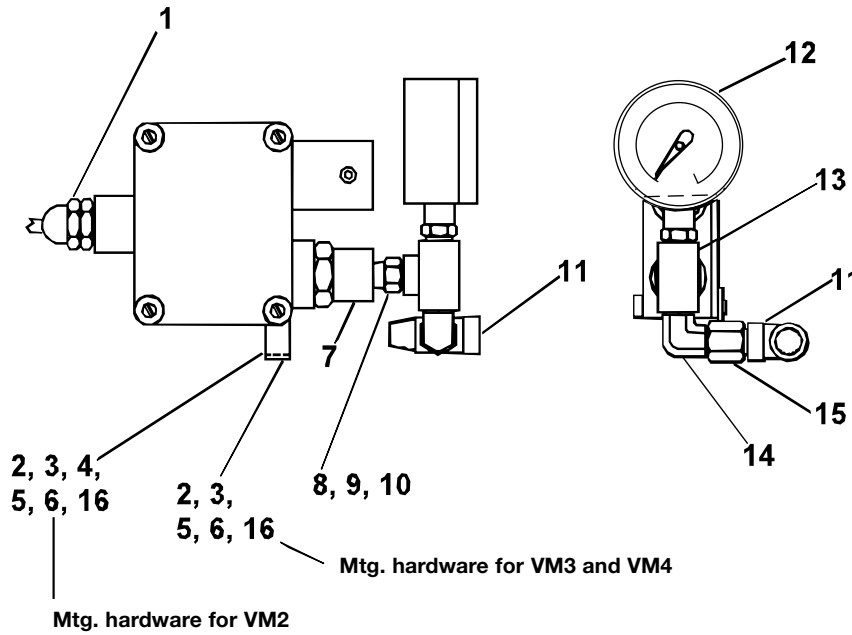

Figure 11, Pressure Switch Assembly

Repair Parts List for Figure 11

Item	Part Number	Qty.	Description	Item	Part Number	Qty.	Description
1	DA5752007	1	Liq. Tight Connector	9	FZ1630	2	Reducer Bushing
2	DA4035111	1	Bracket	10	FZ1608	1	Hex Nipple
3	B1351028	1	1/4"-20 x 1/2" Ig. Socket Head Cap Screw	11	Y803096	1	Street Tee
4	B1001066	1	1/4" Lock Washer	12	G2535L	1	Gauge
5	B1089108	1	1/4" Flat Washer	13	FZ1612	1	Tee
6	B1094108	1	3/8" Flat Washer	14	CJ456096	1	Street Elbow
7	DA2271372	1	Pressure Switch	15	DA3031096	1	Fitting
8	CN443096	1	Pipe Nipple	16	B1001046	1	Screw

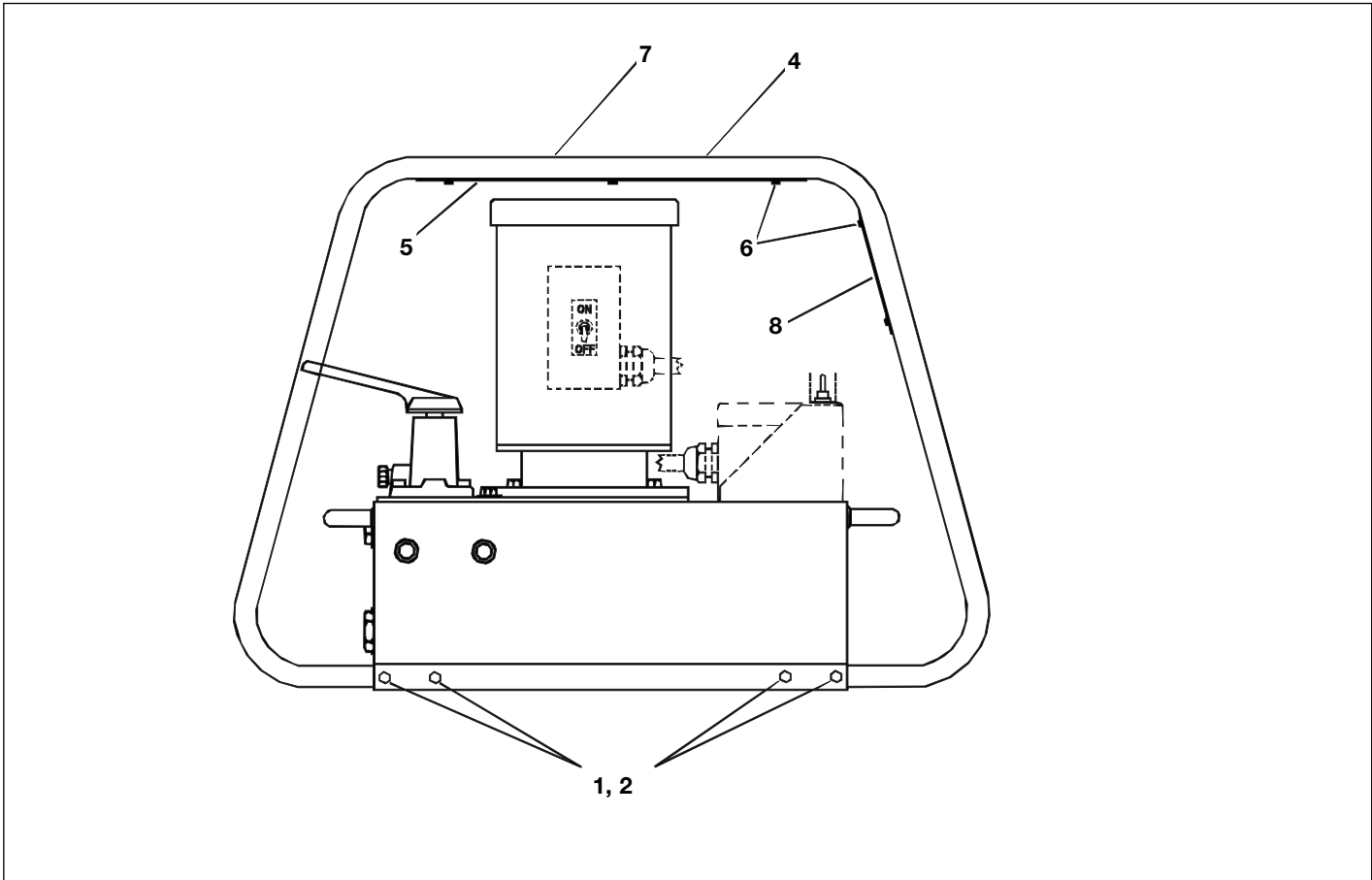

Figure 12, Roll Bar Assembly

Repair Parts List for Figure 12							
Item	Part Number	Qty.	Description	Item	Part Number	Qty.	Description
1	CBB627046-1A	8	Screw	6	CB558028	10	Self-Tapping Screw
2	BSS5632D	8	Lock Nut	7	CL544026	1	Decal
4	DA4254201	2	Roll Bar	8	DA4518098	1	Plate (2 gallon models)
5	DA4340098	1	Cover Plate (2 gallon models)	9	DA4517098	1	Plate (5 gallon models)
	DA4341098	1	Cover Plate (5 gallon models)				

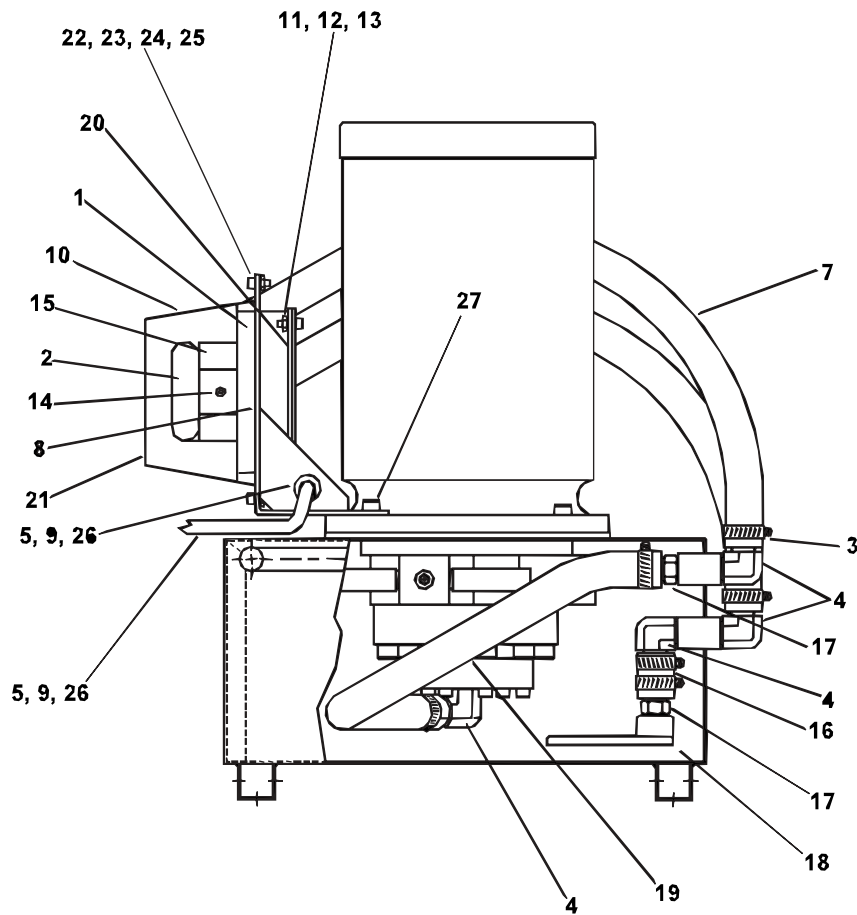

Figure 13, Heat Exchanger Assembly

Repair Parts List for Figure 13

Item	Part Number	Qty.	Description	Item	Part Number	Qty.	Description
1	C637885	1	Fan (115 Volt)	15	CA838098	2	Cover Lock
	F1885	1	Fan (230 Volt)	16	DA3606268SR	1	Hose
2	CA969885	1	Heat Exchanger		DA4986268	1	Hose (EPR)
3	CB40299	8	Hose Clamp	17	CB117096	2	Connector
4	CB46096	4	Elbow	18	CV838950SR	1	Filter Assembly
5	DA3740450SR	1	Power Cord (19" Long)	19	DA3607268SR	1	Hose
6	CR759291	1	Cord Bushing		DA4987268	1	EPR Hose
7	DA3732268SR	2	Hose	20	DA3838590	1	Guard
	DA4985268	2	Hose (EPR)	21	CA837098	1	Shroud
8	DA3734111	1	Mounting Bracket	22	B1007108	8	5/32" Flat Washer
9	DA4630269SR	2	Shrink Tube	23	B1321028	4	#10-24 x 1/2" Lg. Capscrew
10	C201026	1	Voltage Decal (115 Volt)	24	B1064066	4	#10 Lock Washer
	DA2823026	1	Voltage Decal (230 Volt)	25	B1017121	4	#10 Hex Nut
11	BC1310628	8	#6-32 x 5/8" Lg. Capscrew	26	DA5752007	1	Strain Relief
12	B1013121	8	#6-32 Hex Nut	27	CBB1025046-1B	2	Screw
13	B1062066	4	#6 Lock Washer	28	CJ458885	1	Nut
14	Y697003	2	Rivet				

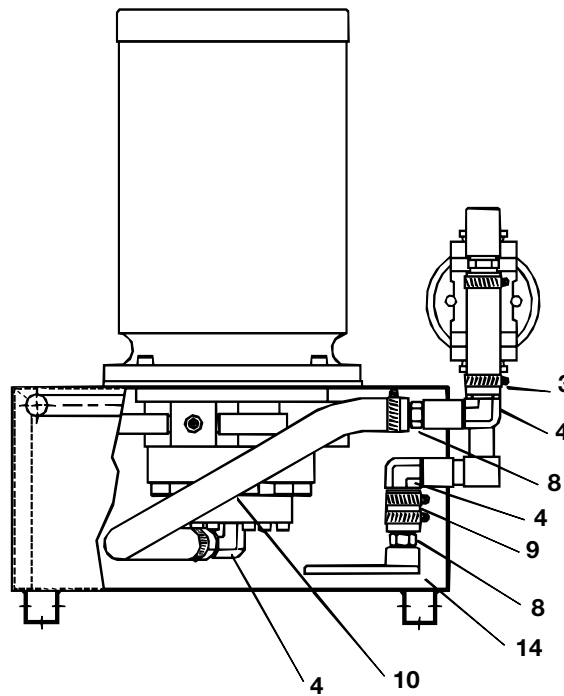
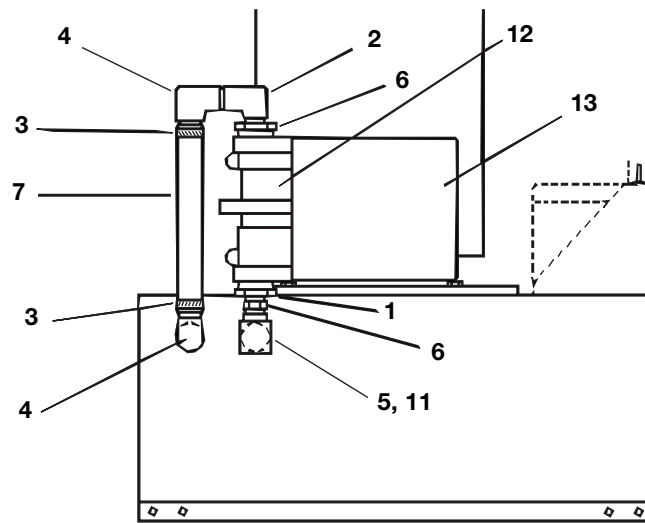

Figure 14, Intake Filter

Repair Part List for Figure 14

Item	Part Number	Qty.	Description	Item	Part Number	Qty.	Description
1	CJ651096	1	Nipple, 3/8" NPT (2 & 5 Gallon)	7	DA4334268	1	6.125" Hose
	DA4332431	1	Nipple, 3/8" NPT (10 Gallon)	8	CB117096	2	Connector, 3/8" NPT Hose Barb
2	CJ655291	1	Street Elbow, 3/8" NPT	9	DA3606268SR	1	2" Hose
3	CB40299	6	Hose Clamp	10	DA3607268SR	1	15.25" Hose
4	CB46096	4	Elbow, 3/8"NPT x 5/8" Hose Barb	11	DA541095	1	Nipple, 3/8" NPT
5	CN330096	1	Elbow, 3/8" NPT Female	12	DA4333118	1	Manifold & Filter Assembly
6	F100095-26	2	Reducer	13	PFE-250	1	Filter Element
				14	CV838950SR	1	Intake Filter Assembly

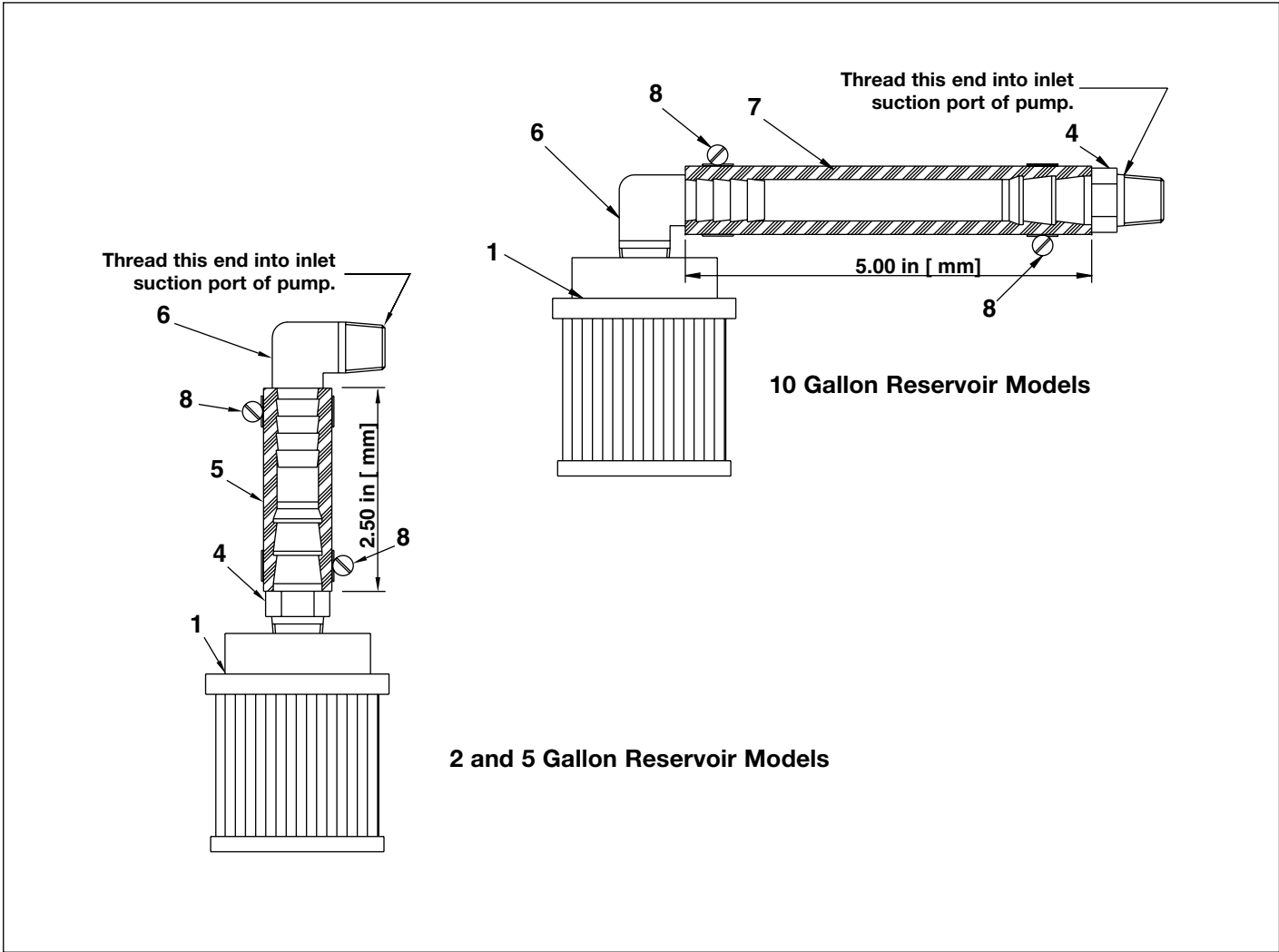
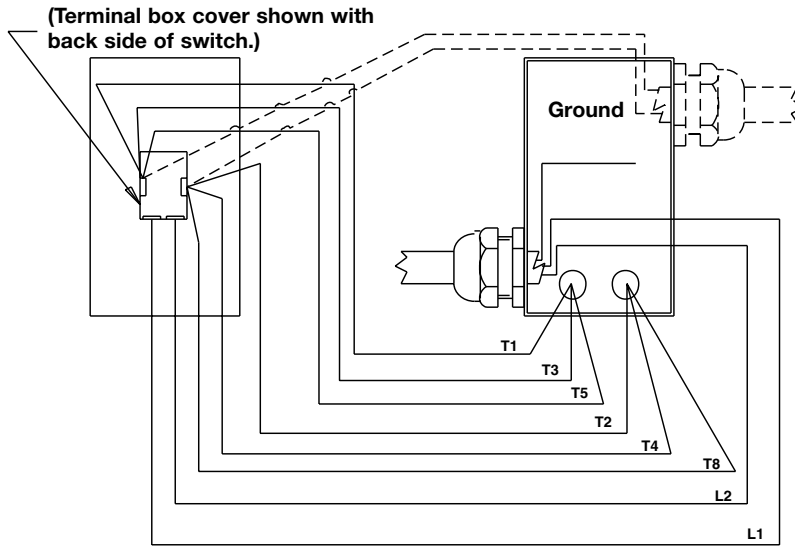

Figure 15, Special Filter Assembly (-KOR models)

Repair Part List for Figure 15							
Item	Part Number	Qty.	Description	Item	Part Number	Qty.	Description
1	DA10810118	1	Sump Strainer	6	CB46096	1	Coupling
4	CB117096	1	Coupling	7	DA10921268	1	Hose
5	DA10922268	1	Hose	8	CB40299	2	Hose Clamp

110 V, 1 Phase



220 V, 1 Phase

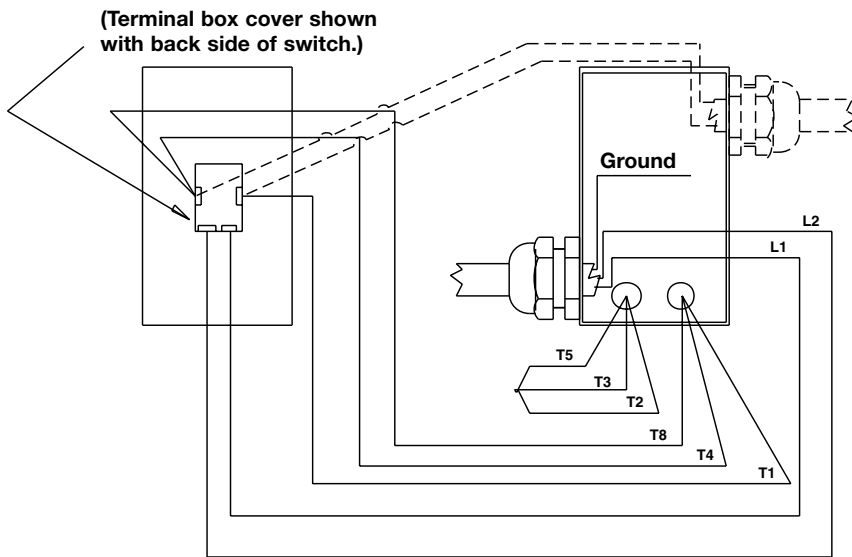
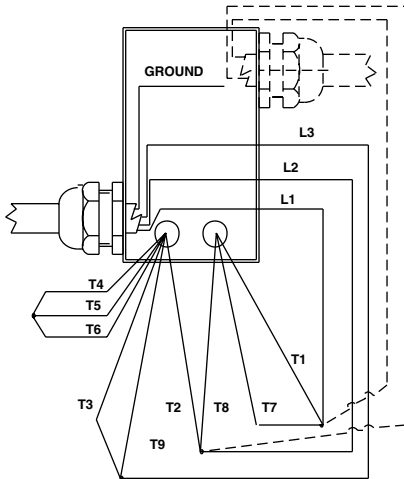

Figure 16, Manual Valve Motor Terminal Box Wiring

230 V, 3 Phase

(customer supplied)



110 V, 1 Phase

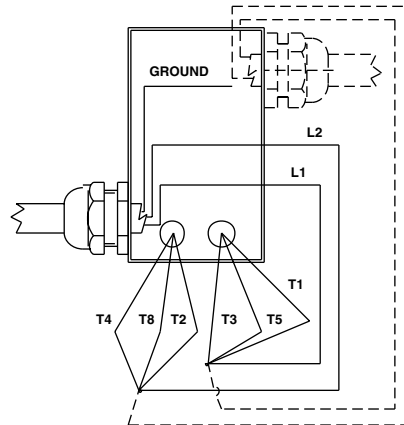

460, 575 V, 3 Phase

(customer supplied)

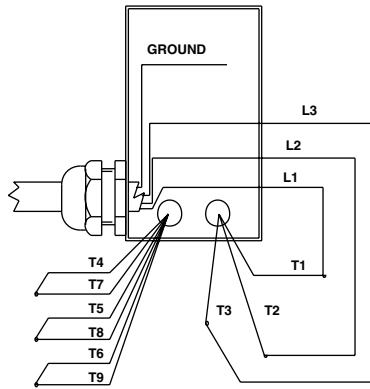

220 V, 1 Phase

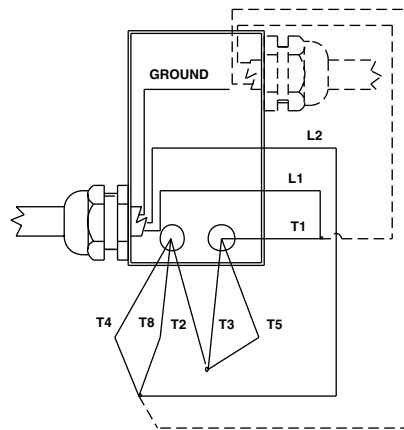

Figure 17, Electric Valve Motor Terminal Box Wiring

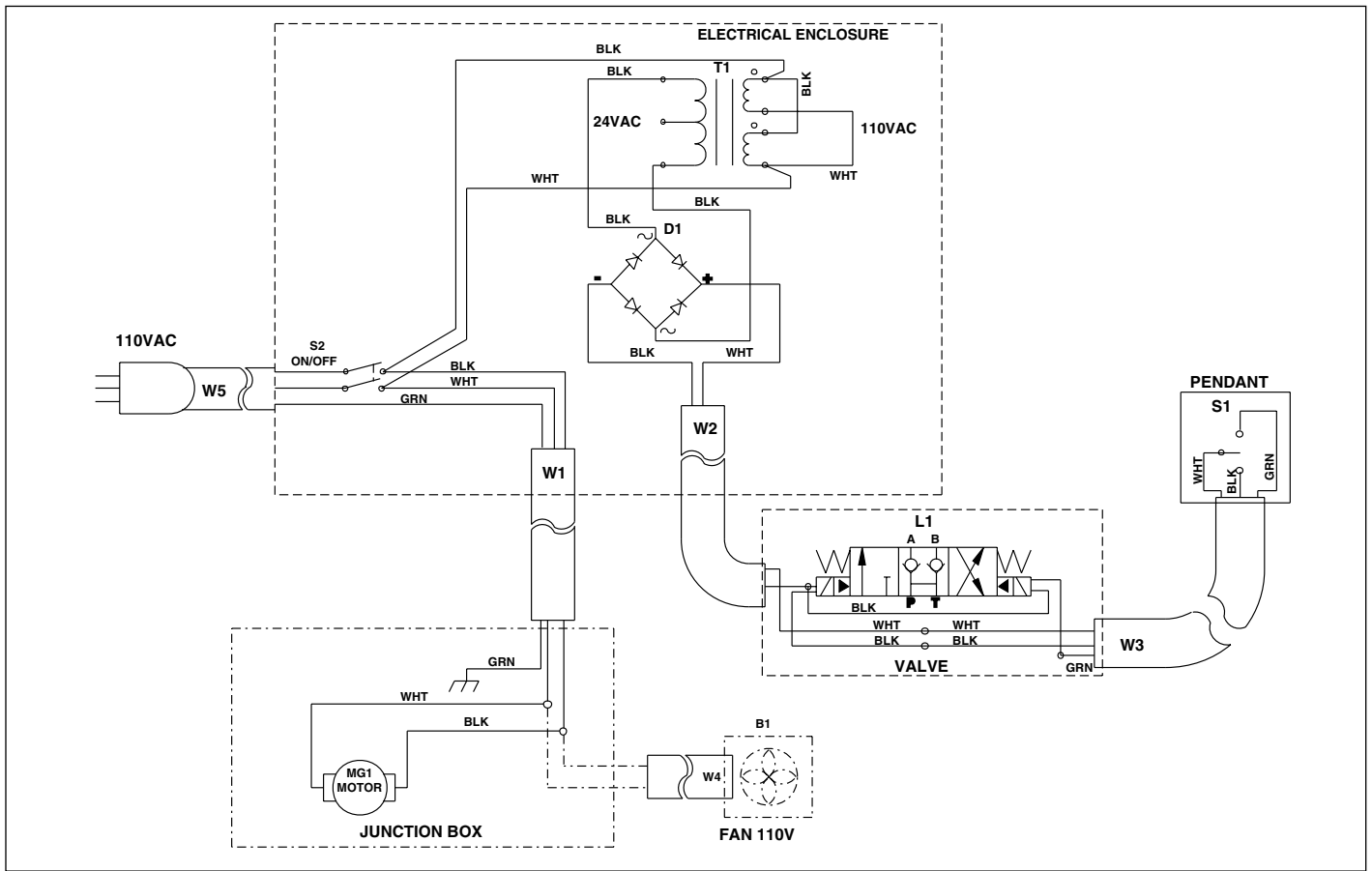

Figure 18, 110-Volt Pump with 4-way Electric Solenoid Valve and Heat Exchanger

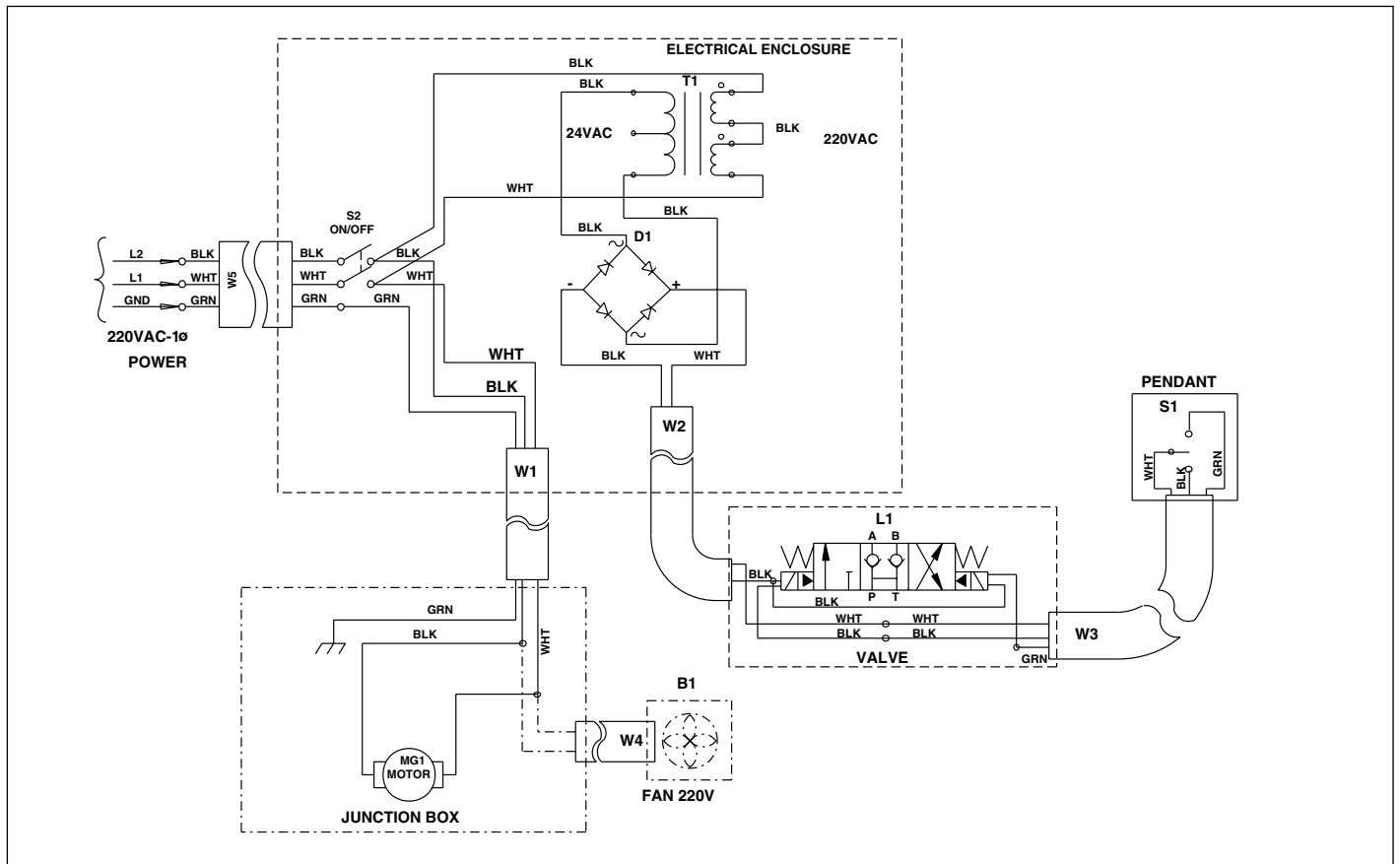

Figure 19, 220-Volt, 1-Pump with 4-way Electric Solenoid Valve

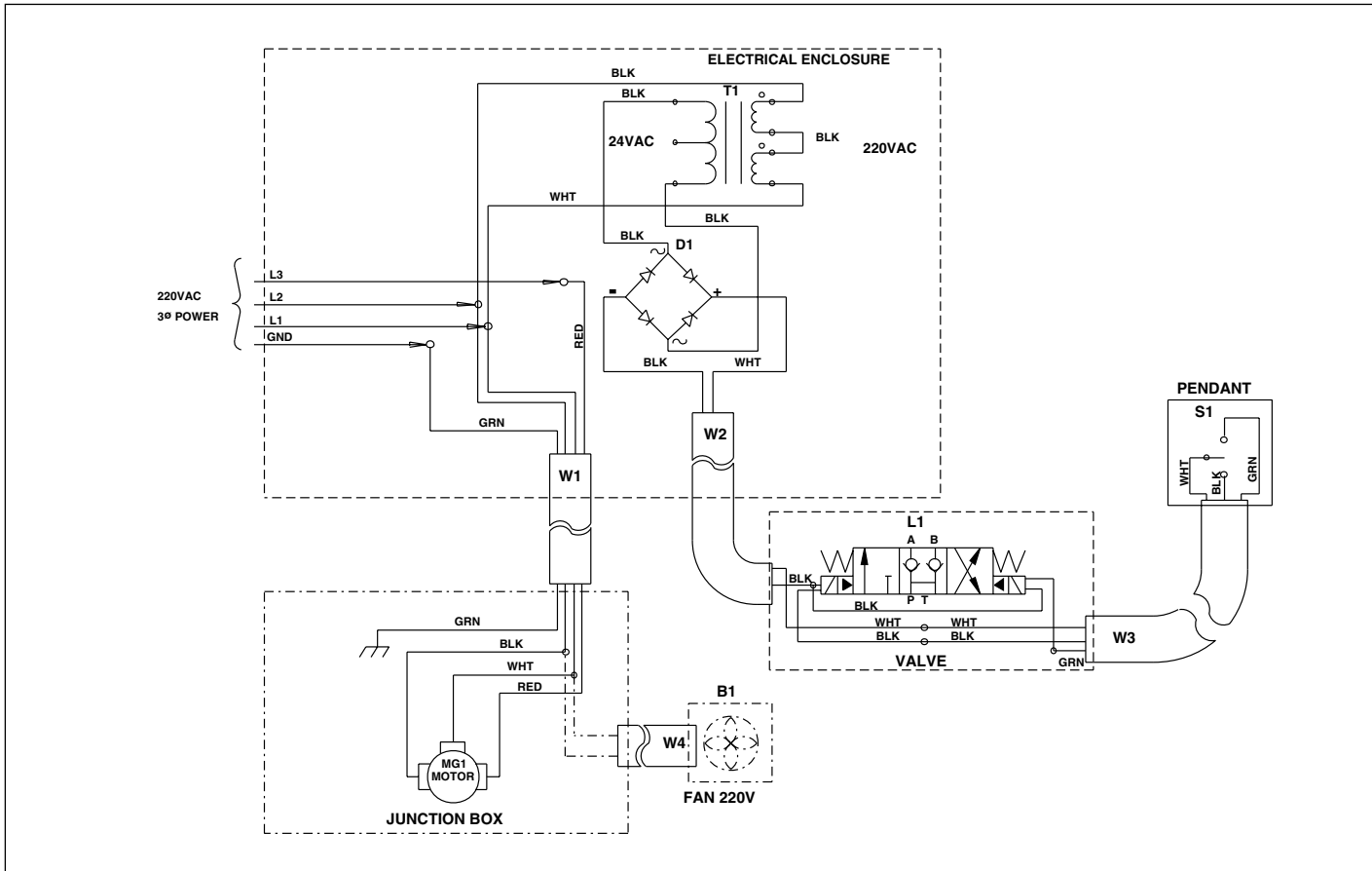

Figure 20, 220-Volt 3-Phase Pump with 4-Way Electric Solenoid Valve and Heat Exchanger

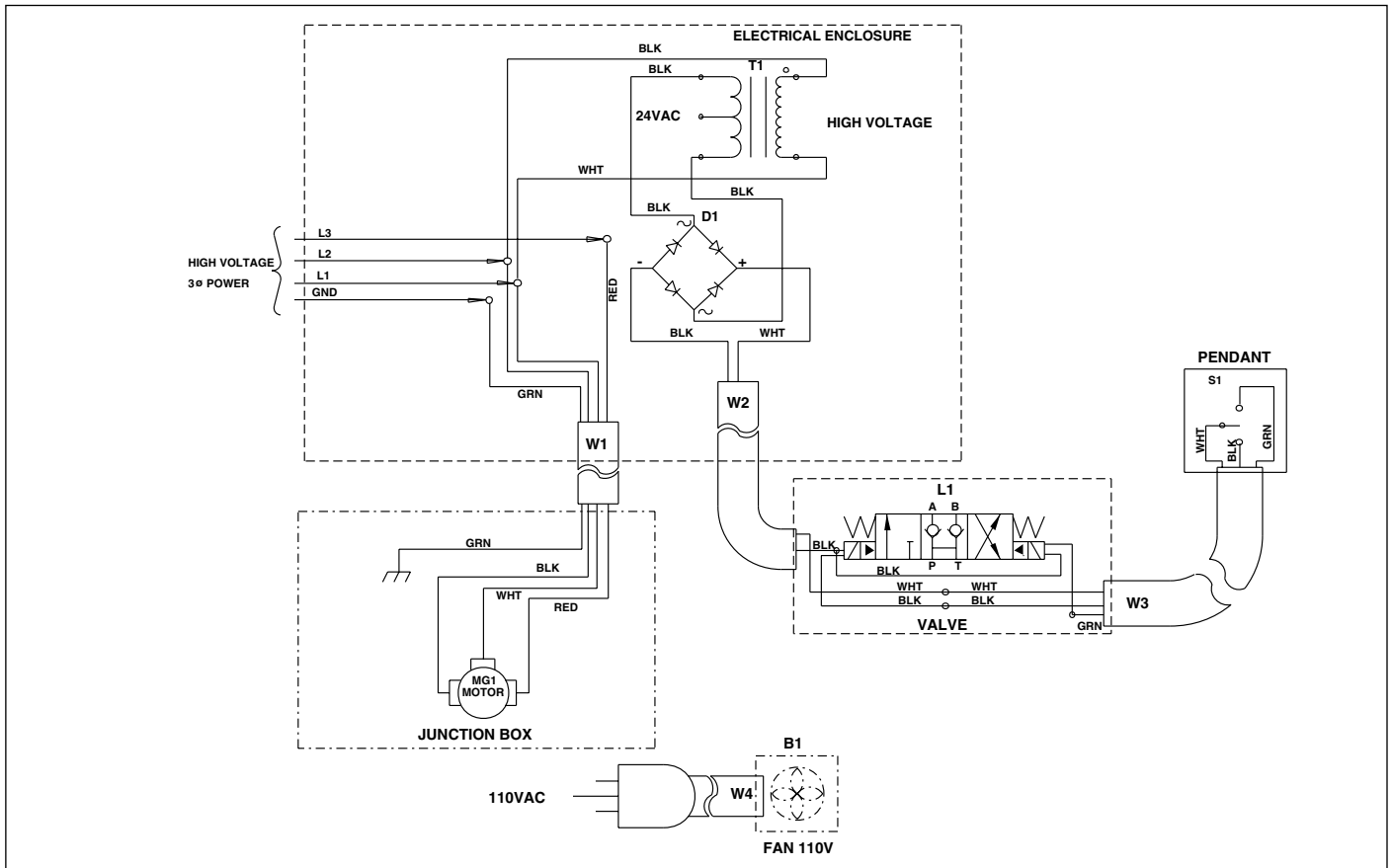

Figure 21, 460/575-Volt, 3-Phase Pump with 4-Way Electric Solenoid Valve

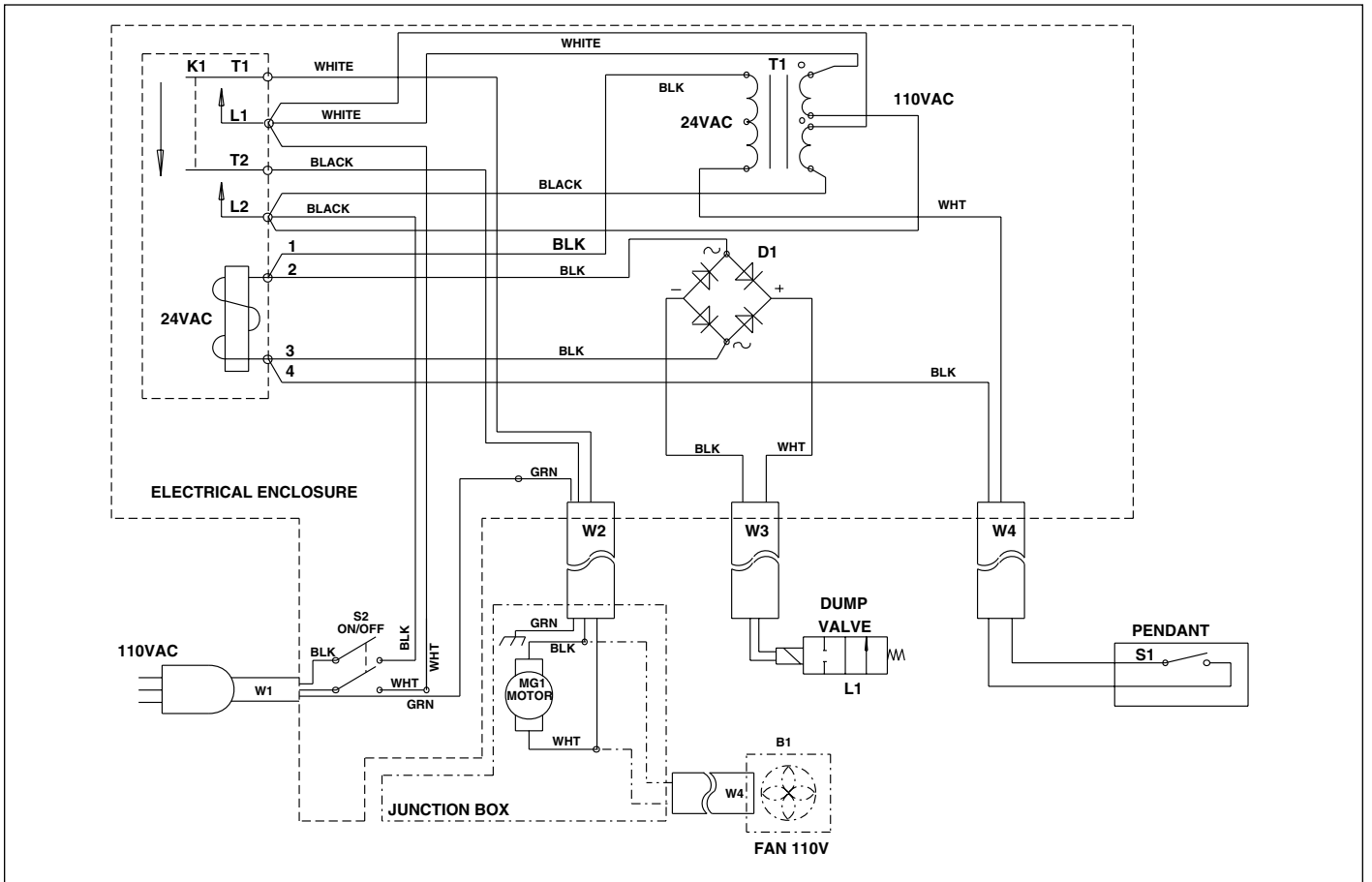

Figure 22, 110-Volt Pump with Dump Valve

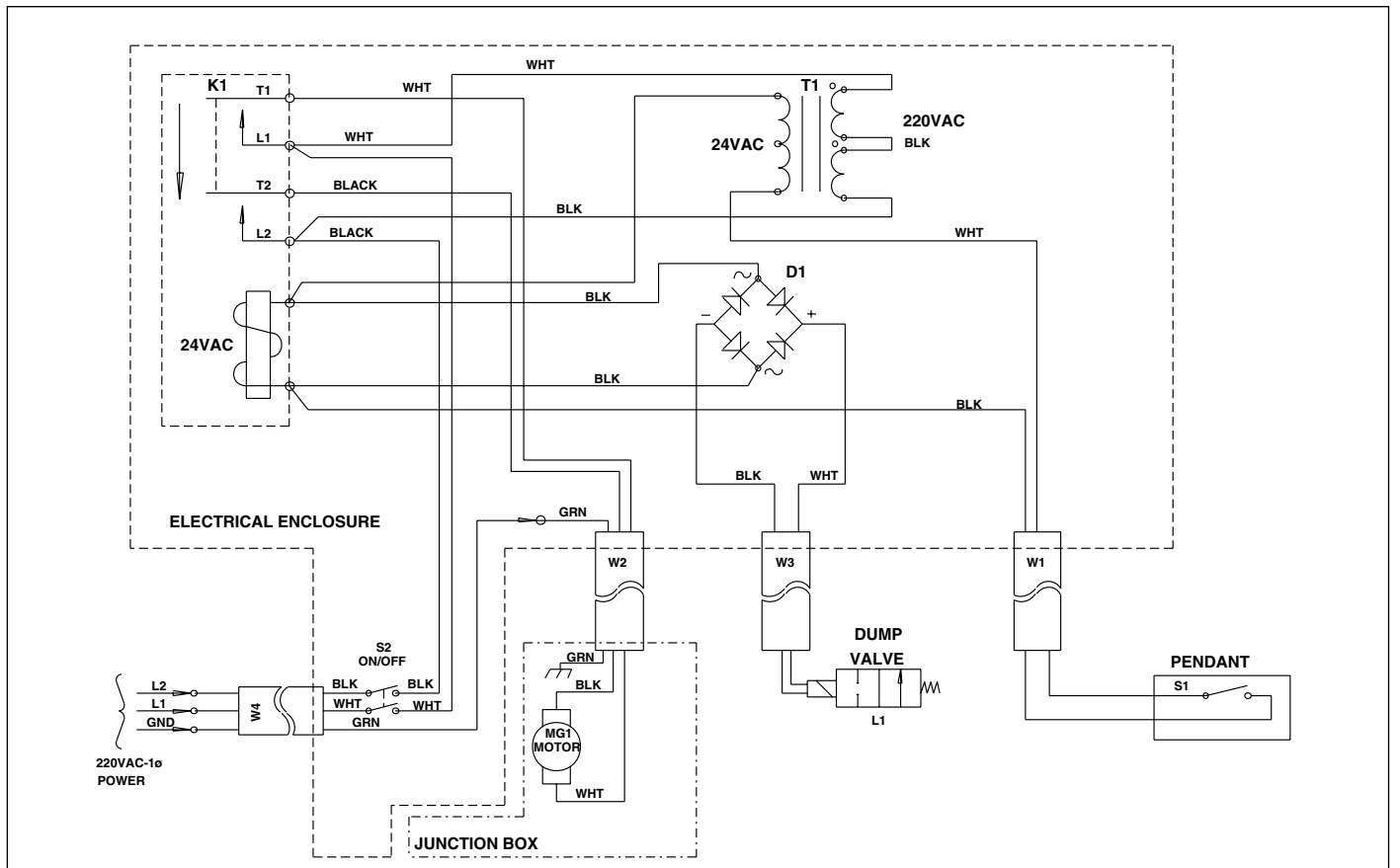

Figure 23, 220 Volt, 1-Phase Pump with Dump Valve

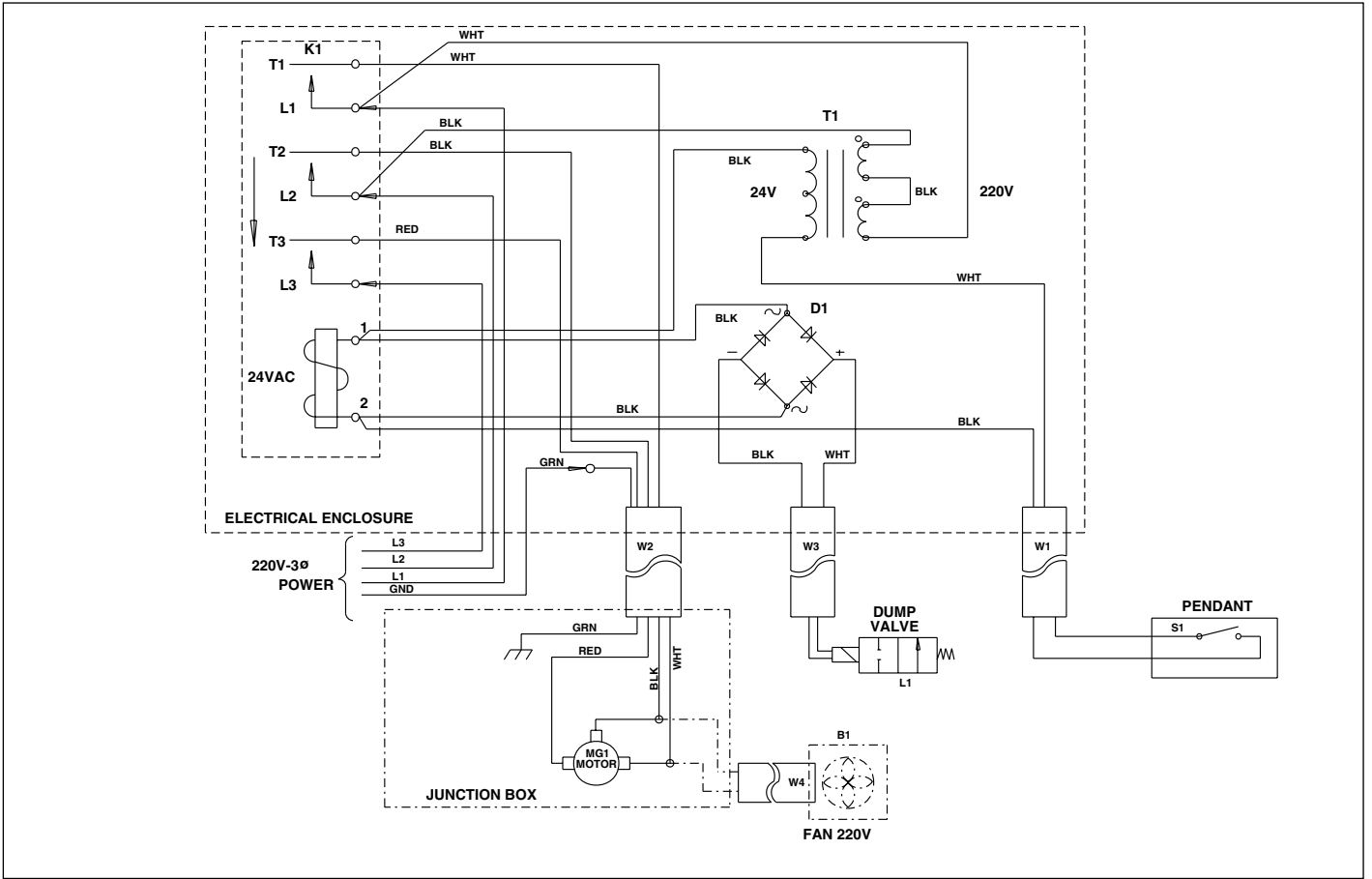

Figure 24, 220-Volt 3-Phase Pump with Dump Valve

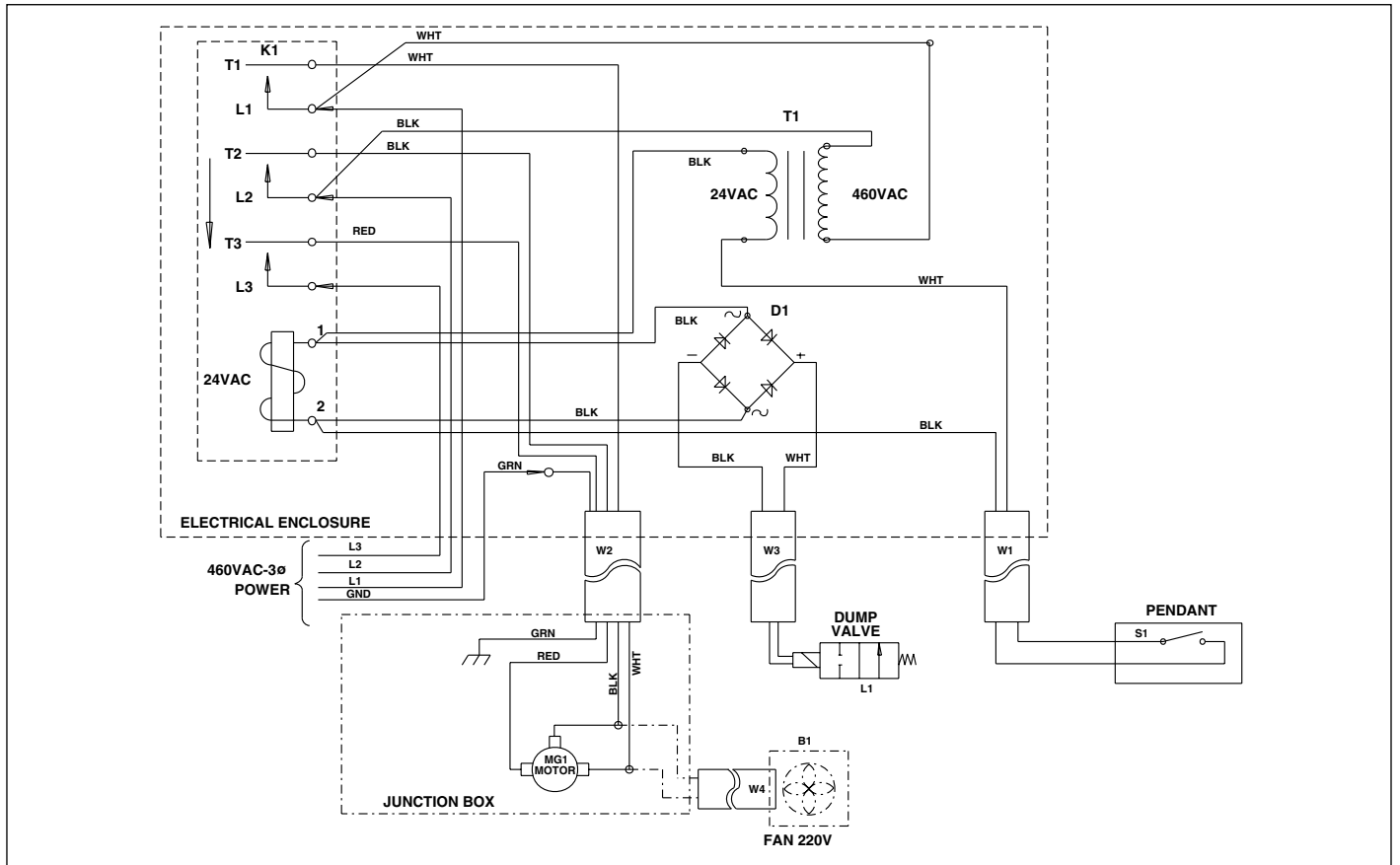

Figure 25, 460-Volt, 3-Phase Pump with Dump Valve

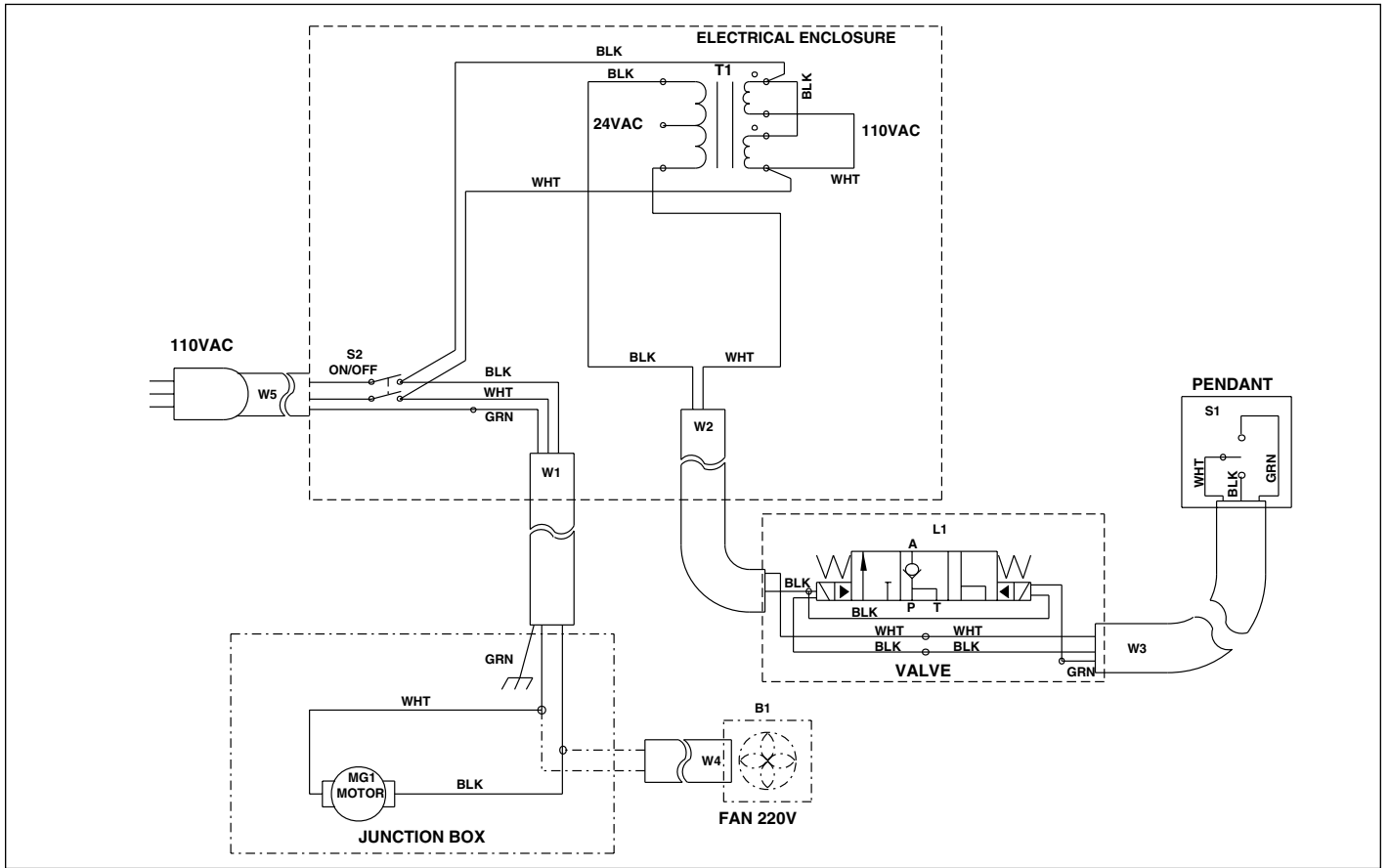

Figure 26, 110-Volt Pump with 3-Way Electric Solenoid Valve and Heat Exchanger

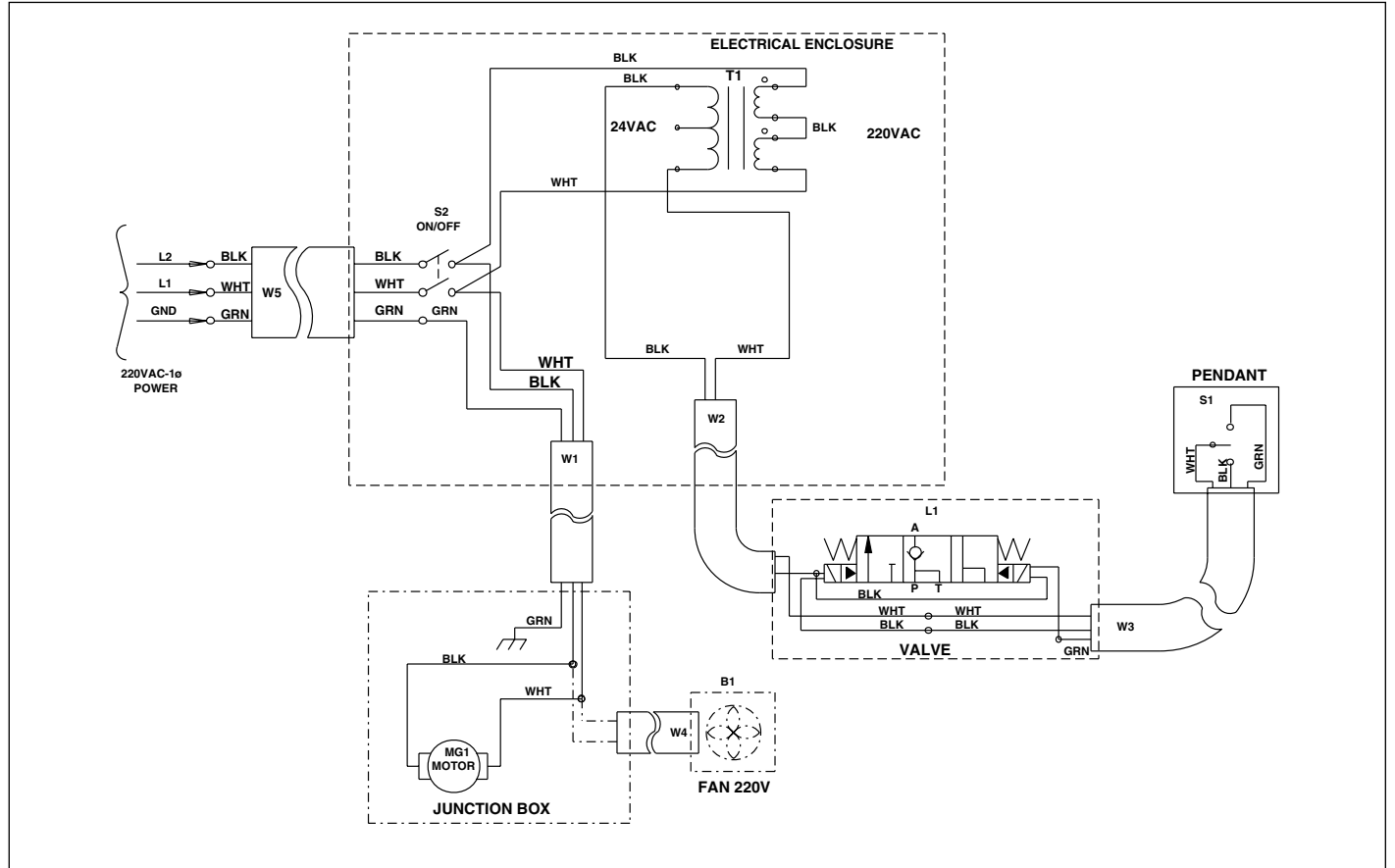

Figure 27, 220-Volt, 1-Phase Pump with 3-Way Electric Solenoid Valve

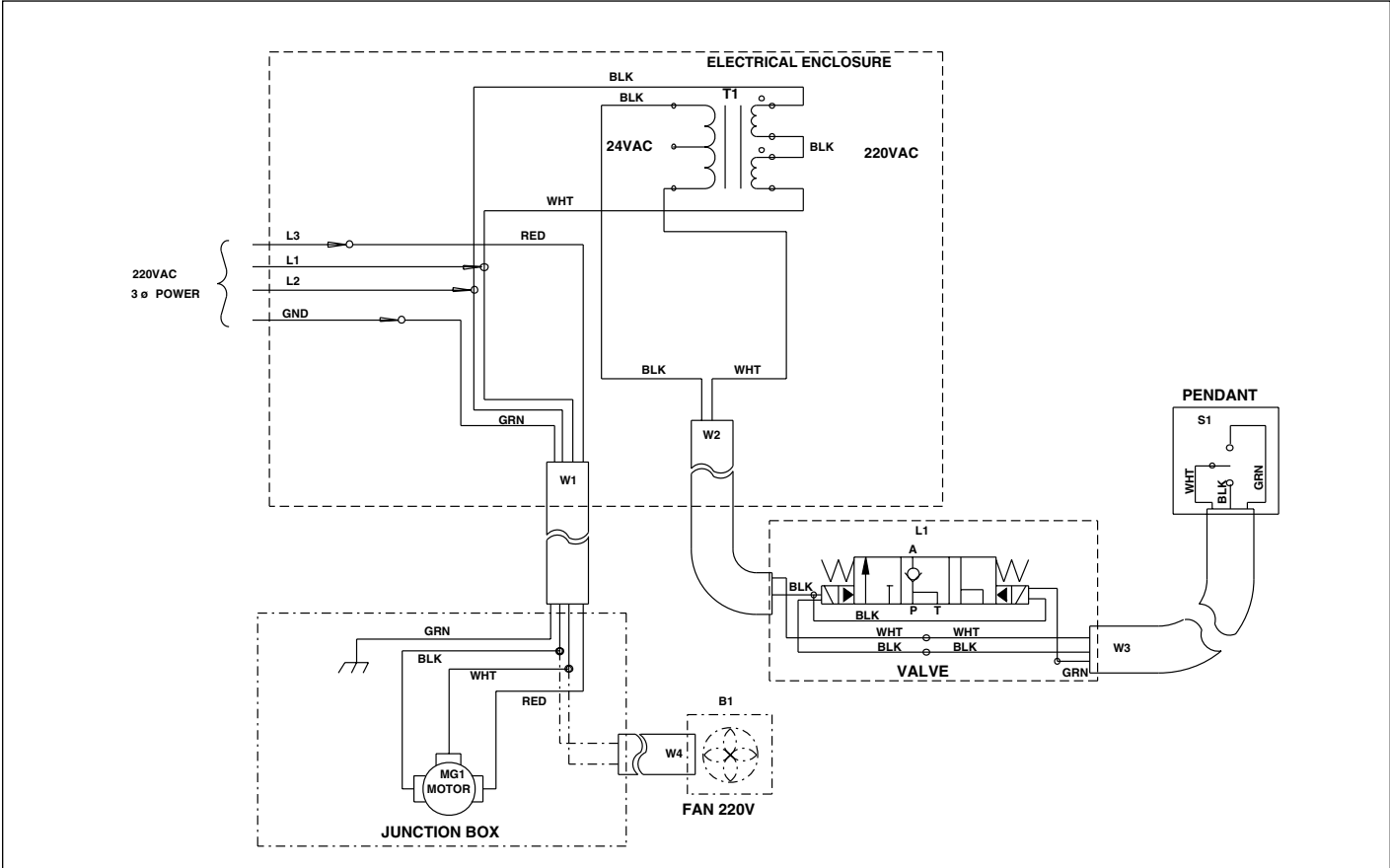

Figure 28, 220-Volt 3-Phase Pump with 3-Way Electric Solenoid Valve and Heat Exchanger

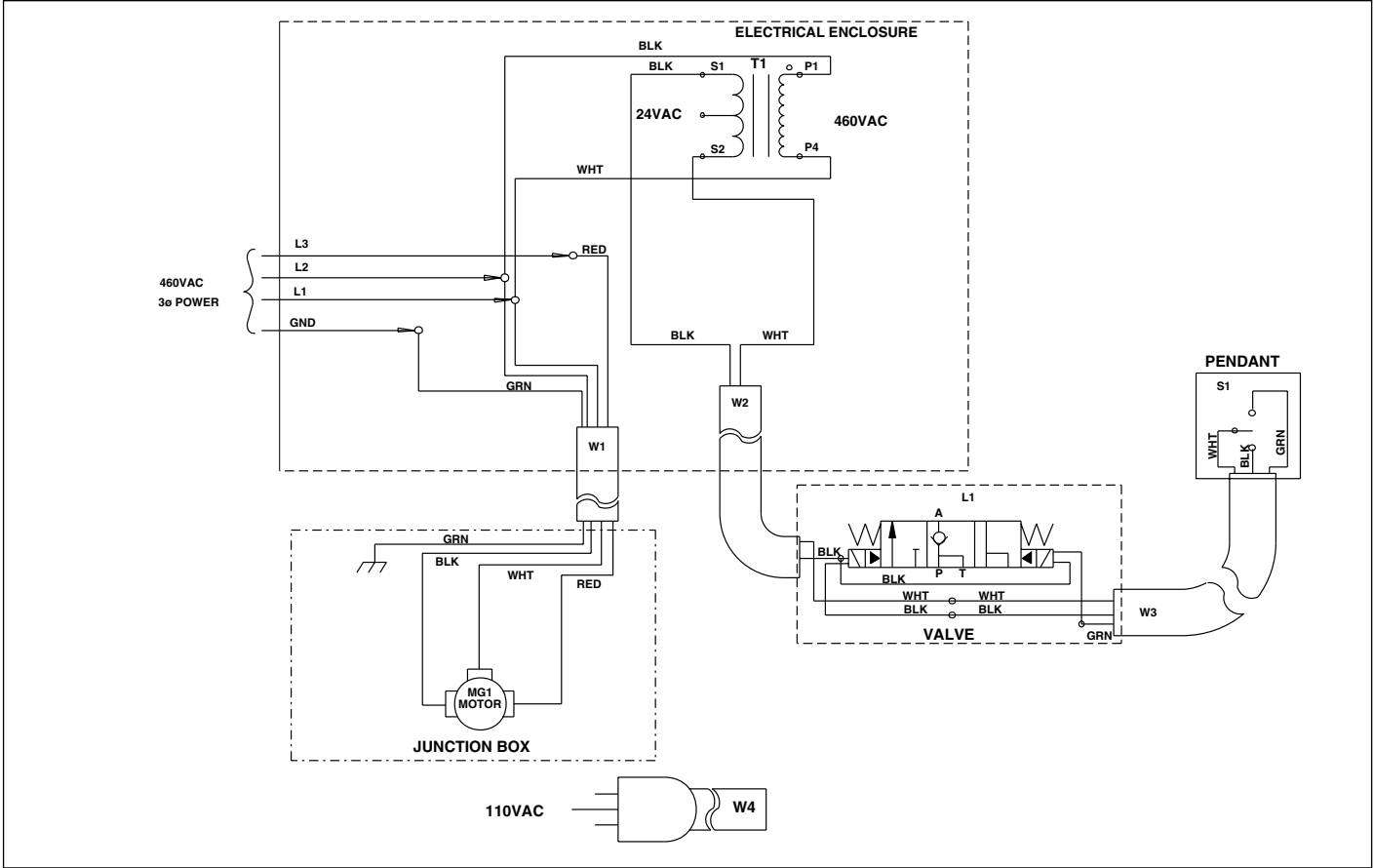

Figure 29, 460-Volt, 3-Phase Pump with 3-Way Electric Solenoid Valve and Heat Exchanger

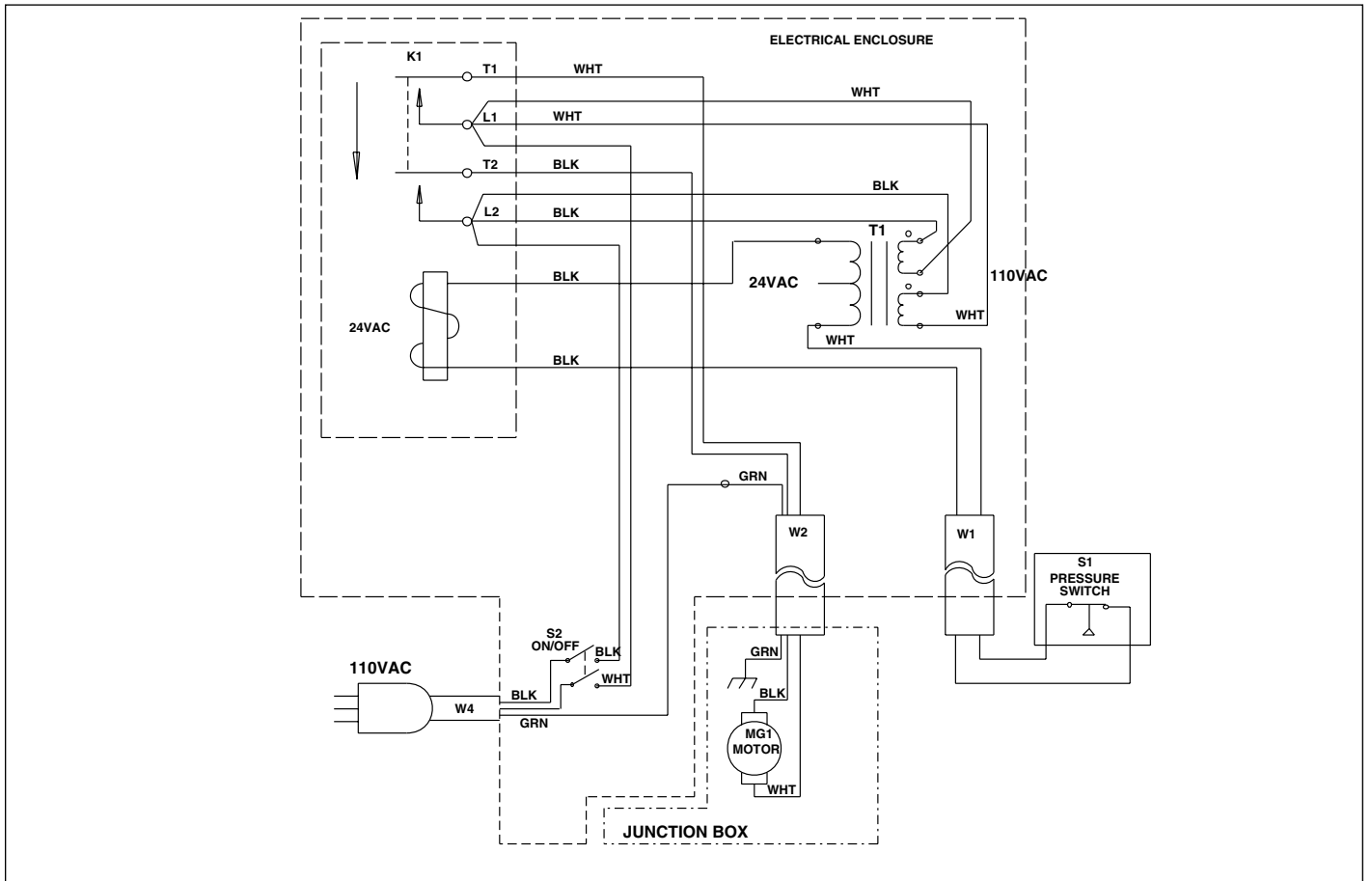

Figure 30, 110-Volt with Pressure Switch

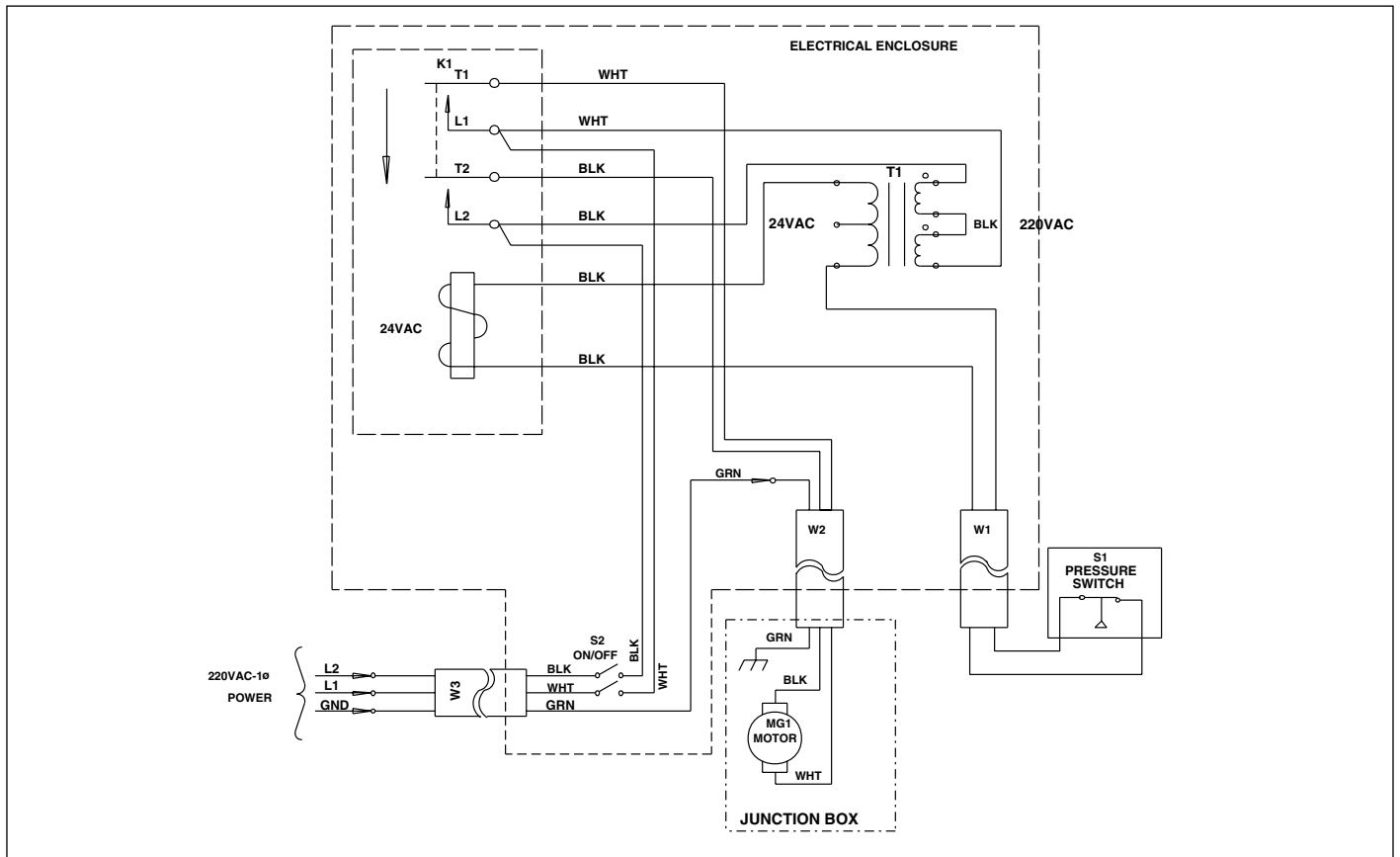

Figure 31, 220-Volt, 1-Phase Pump with Pressure Switch

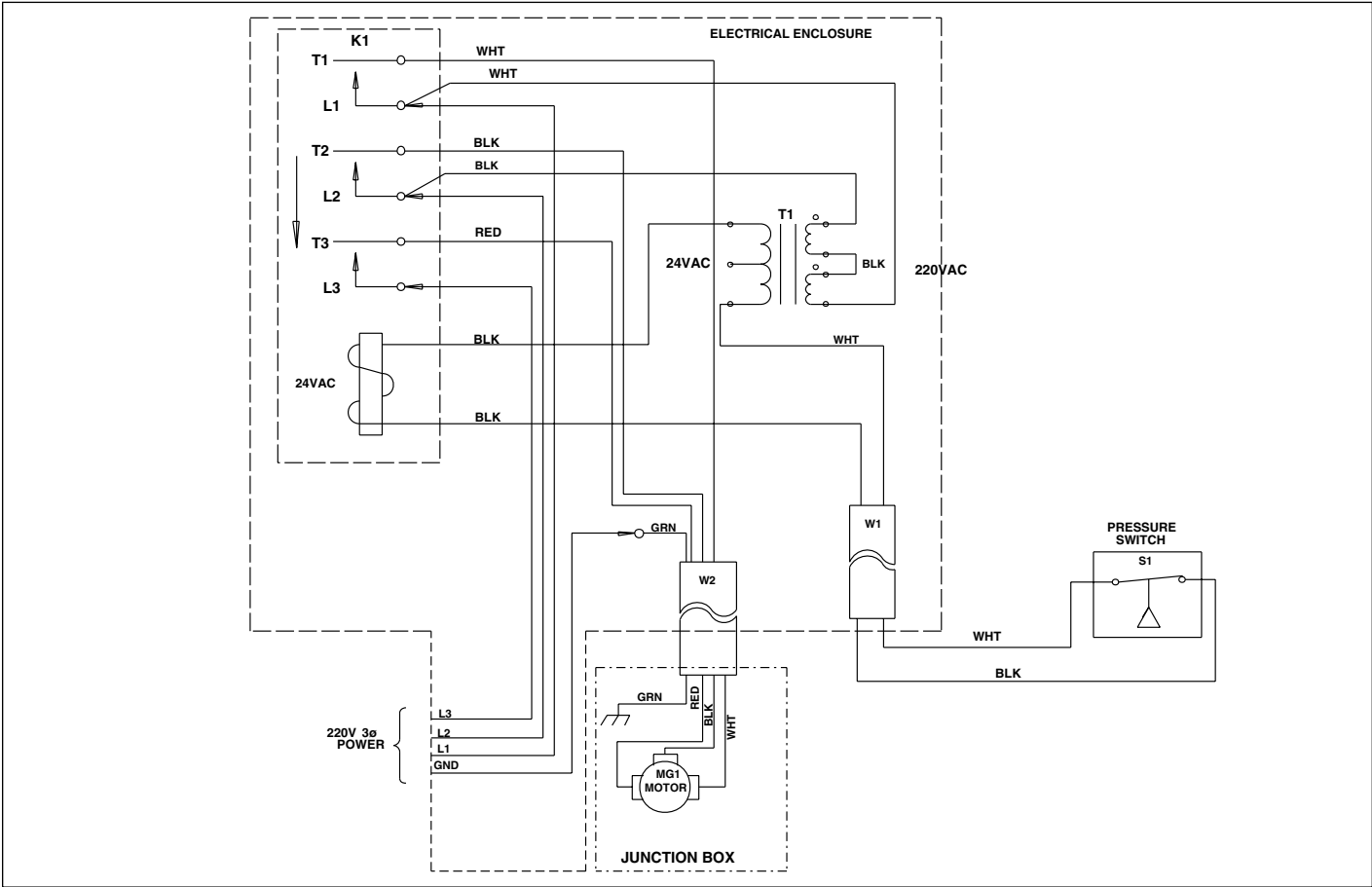

Figure 32, 220-Volt, 3-Phase with Pressure Switch

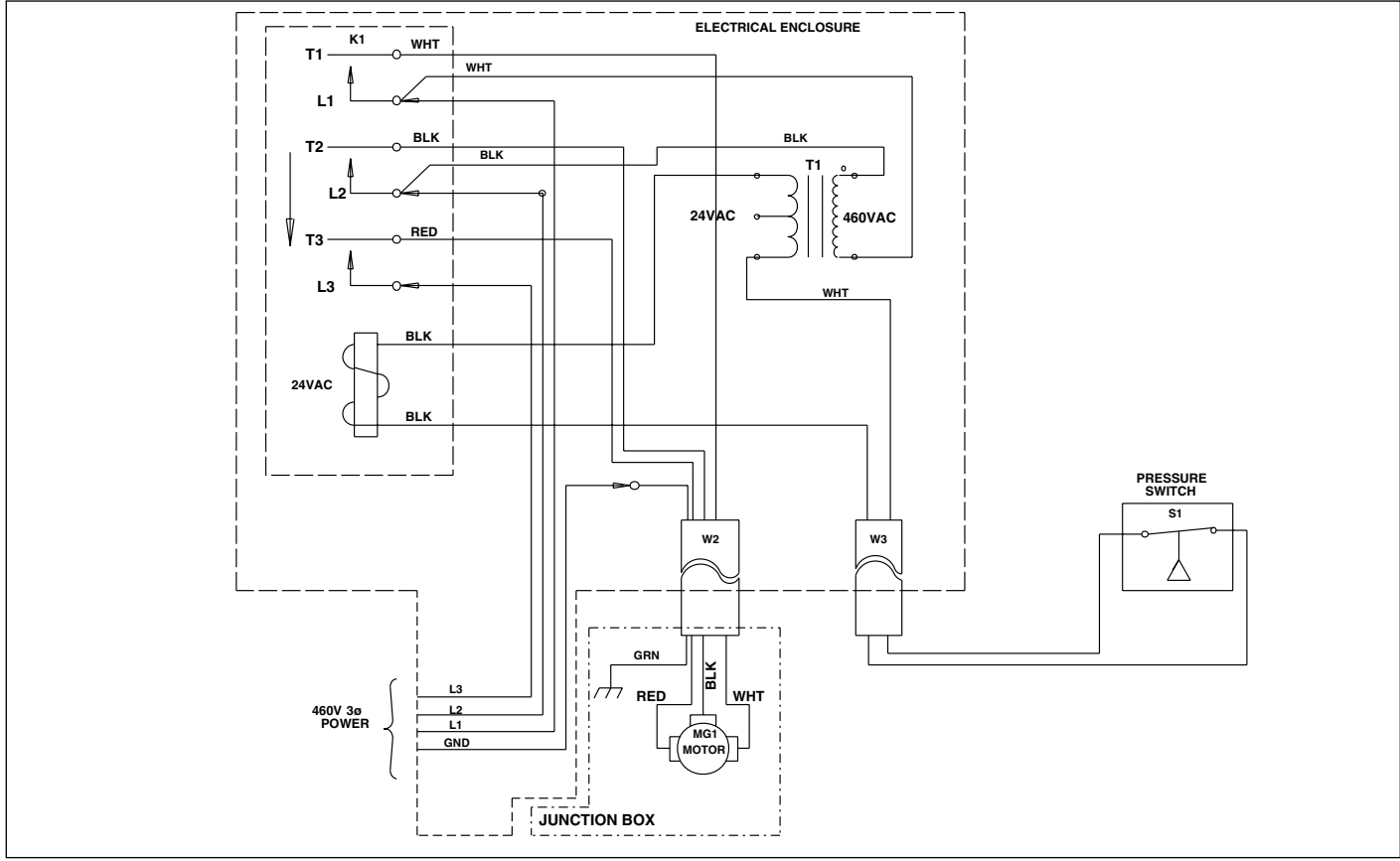

Figure 33, 460-Volt, 3-Phase Pump with Pressure Switch

Enerpac Worldwide Locations

◆ e-mail: info@enerpac.com

◆ internet: www.enerpac.com

Australia

ENERPAC, Applied Power Australia Ltd.
Block V Unit 3
Regents Park Estate
391 Park Road
Regents Park NSW 2143
(P.O. Box 261) Australia
Tel: +61 297 438 988
Fax: +61 297 438 648

Canada

Actuant Canada Corporation
6615 Ordan Drive, Unit 14-15
Mississauga, Ontario L5T 1X2
Tel: +1 905 564 5749
Fax: +1 905 564 0305

Toll Free:

Tel: +1 800 268 4987
Fax: +1 800 461 2456

China

Applied Power China Ltd.
1F, 269 Fute N. Road
Waigaoqiao Free Trade Zone
Pudong New District
Shanghai, 200 131
China
Tel: +86 21 5866 9099
Fax: +86 21 5866 7156

France, Turkey, Greece, Africa, Middle East

ENERPAC S.A.
B.P. 200
Parc d'Activités
du Moulin de Massy
F-91882 Massy CEDEX (Paris) France
Tel: +33 1 601 368 68
Fax: +33 1 692 037 50

Germany, Switzerland, Austria, Eastern Europe

ENERPAC
Applied Power GmbH
P.O. Box 300113
D-40401 Düsseldorf
Germany
Tel: +49 211 471 490
Fax: +49 211 471 49 28

Hong Kong

ENERPAC
Room 907 Workingberg
Commercial Building
41-47 Marble Road
North Point
Tel: +852-2561 6295
Fax: +852-2561 6772

India

ENERPAC
Hydraulics (India) Pvt Ltd
Plot No. A-571
MIDC, TTC Industrial Area
Mahape-400 701
Navi Mumbai, India
Tel: +91 22 769 47 78
Fax: +91 22 769 84 73

Italy

ENERPAC
Applied Power Italiana S.p.A.
Via Canova 4
20094 Corsico (Milano)
Tel: +39 02 4861 1110
Fax: +39 02 4860 1288

Japan

Applied Power Japan Ltd.
1-1-11, Shimomae
Toda-shi
Saitama Pref.
Japan 335-0016
Tel: +81-48-430-2311
Fax: +81-48-430-1117

Mexico

ENERPAC Applied Power
Mexico S.A. de C.V.
Avenida Principal
La Paz #100
Fracc. Industrial La Paz
42092 Pachuca, Hidalgo
Tel: +52 771 337 00
Fax: +52 771 838 00

The Netherlands, Belgium, Luxembourg, Sweden, Denmark, Norway, Finland, United Kingdom, Ireland

ENERPAC B.V.
Storkstraat 25
P.O. Box 269, 3900 AG Veenendaal
The Netherlands
Tel: +31 318 535 911
Fax: +31 318 525 613
+31 318 535 848
UK, Ireland
Tel: +44 01527 598 900
Fax: +44 01527 585 500

Singapore

Applied Power Asia Pte Ltd
No. 8, Ang Mo Kio,
Industrial Park 2
#01-00
Singapore 569500
Thomson Road, P.O. Box 114
Singapore 915704
Tel: +65 484 5108
Fax: +65 484 5669

South Korea

ENERPAC
Applied Power Korea Ltd.
163-12 Dodang-Dong
Wonmi-Ku, Buchun-shi
Kyunggi-Do
Republic of Korea
Tel: +82 32 675 08 36
Fax: +82 32 675 30 02/73

Spain, Portugal

ENERPAC
Applied Power International S.A.
Avda. Camino de lo Cortao
21 - Nave 3
San Sebastian de los Reyes
28709 Madrid
Spain
Tel: +34 91 661 11 25
Fax: +34 91 661 47 89

USA, Latin America and Caribbean

ENERPAC
P.O. Box 3241
6101 N. Baker Road
Milwaukee, WI 53209 USA
Tel: +1 262 781 6600
Fax: +1 262 783 9562

User inquiries:

+1 800 433 2766

Distributor inquiries/orders:

+1 800 558 0530

All Enerpac products are guaranteed against defects in workmanship and materials for as long as you own them.
For your nearest authorized Enerpac Service Center, visit us at www.enerpac.com

092501

NS1299D