

CDB BLOCK CYLINDERS

L2329 Rev. H 09/2018

For Date Codes beginning with:
Letter "O" & "A" (Model No. CDB18202, CDB18502, CDB40252, CDB40502,
 CDB70252, CDB70502, CDB180252, CDB180502, CDB280562)
Letter "A" & "B" (Model No. CDB10162 and CDB10362)

NOTE: Lubricate all seals prior to assembly.
 Item #3 (Stop Ring) must be replaced when parts from any CDB seal kit (★ or ★★) are installed.
 To service: Drill out stake. After service, stake lightly once, 90° from installation notch or hole.

Item #6 (U-Cup):
 For older cylinders, a U-Cup replaces the o-ring and back-up that was previously used on 10kN and 18kN models.

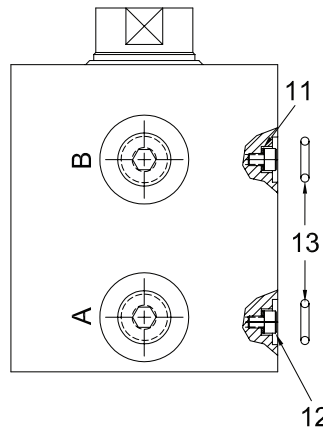
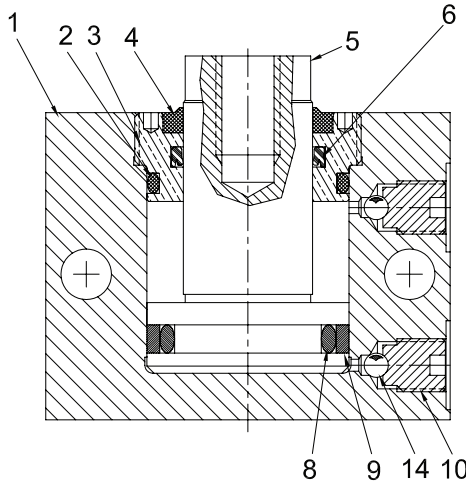

Item #10 (BSPP Plug) torque as follows:
 .125 BSPP: 45-50 in-lbs. [5,1-6,2 Nm]
 .250 BSPP: 40-70 in-lbs. [4,5-7,9 Nm]

Item #12 (Plug Bolt) torque as follows:
 For 10, 18, 40, & 70 kN: 8-10 in-lbs. [0,9-1,1 Nm]
 For 180 & 280 kN: 34-36 in-lbs. [3,8-4,0 Nm]

IMPORTANT:

Plunger replacement information:

- The old-style plunger (item 5) is no longer available. A new-style plunger must be ordered if plunger replacement is necessary.
- Refer to Repair Parts Sheet L4161 for part number of new-style plunger (replaces item 5).
- The new-style plunger O-ring (replaces item 8) **MUST** be used with the new-style plunger. The new-style plunger O-ring is included only in seal kits ending in "K1" (See RPS L4161).
- The old-style plunger O-ring (item 8) is **NOT USED** with the new-style plunger and should be discarded.
- The Glyd Ring (item 9) is **NOT USED** with the new-style plunger and should be discarded.

REPAIR PARTS LIST

Item	Model Number and Date Code Letter				Qty.	Description
	CDB10162 (A) & (B)	CDB10362 (A) & (B)	CDB18202 (O) & (A)	CDB18502 (O) & (A)		
1	PA1878005	PA1914005	—	—	1	Base (10 kN)
	—	—	PA1879005	PA1915005	1	Base (18 kN)
2	★ B1114203	★ B1114203	★★ B1117203	★★ B1117203	1	O-ring
3	PA2720044	PA2720044	—	—	1	Stop ring (10 kN block)
	—	—	PA2211044	PA2211044	1	Stop ring (18 kN block)
4	★ DQ372041	★ DQ372041	★★ CY474041	★★ CY474041	1	Wiper
5	Part no longer available. See IMPORTANT above.				1	Plunger (old-style)
6	★ DW1060041	★ DW1060041	—	—	1	U-Cup (10 kN)
	—	—	★★ DW1061041	★★ DW1061041	1	U-Cup (18 kN)
8	★ PA2540203	★ PA2540203	★★ PA2541203	★★ PA2541203	1	O-ring (old-style plunger)
9	★ DA11608141	★ DA11608141	—	—	1	Glyd Ring (10 kN)
	—	—	★★ DA11609141	★★ DA11609141	1	Glyd Ring (18 kN)
10	PA1844006	PA1844006	PA1844006	PA1844006	2	1/8 BSPP plug
11	★ PA1286167	★ PA1286167	★★ PA1286167	★★ PA1286167	2	Copper gasket
12	CCA311028-1A	CCA311028-1A	CCA311028-1A	CCA311028-1A	2	Plug Bolt
13	★ B1011203	★ B1011203	★★ B1011203	★★ B1011203	2	O-ring
14	F100016-5	F100016-5	F100016-5	F100016-5	2	Ball

★ Items included in seal kit CDB10K1.
 ★★ Items included in seal kit CDB18K1.

REPAIR PARTS LIST						
Item	Model Number and Date Code Letter				Qty.	Description
	CDB40252 (O)	CDB40502 (O)	CDB70252 (O)	CDB70502 (O)		
1	PA1880005	PA1916005	—	—	1	Base (40 kN)
	—	—	PA1917005	PA1918005	1	Base (70 kN)
2	★ B1126203	★ B1126203	★★ B1223203	★★ B1223203	1	O-ring
3	PA2212044	PA2212044	—	—	1	Stop ring (40 kN block)
	—	—	PA2213044	PA2213044	1	Stop ring (70 kN block)
4	★ CY549041	★ CY549041	★★ CY550041	★★ CY550041	1	Wiper
5	Part no longer available. See IMPORTANT on page 1.				1	Plunger
6	★ PA2174041	★ PA2174041	—	—	1	Rod seal (40 kN)
	—	—	★★ PA2175041	★★ PA2175041	1	Rod seal (70 kN)
8	★ PA2542203	★ PA2542203	★★ PA2543203	★★ PA2543203	1	O-ring
9	★ DA11610141	★ DA11610141	—	—	1	Glyd Ring (10 kN)
	—	—	★★ DA11611141	★★ DA11611141	1	Glyd Ring (18 kN)
10	PA1844006	PA1844006	—	—	2	1/8 BSPP plug
	—	—	PA1845006	PA1845006	2	1/4 BSPP plug
11	★ PA1286167	★ PA1286167	★★ PA1286167	★★ PA1286167	2	Copper gasket
12	PA1545028	PA1545028	PA1545028	PA1545028	2	Socket head cap screw
13	★ B1011203	★ B1011203	★★ B1011203	★★ B1011203	2	O-ring
14	F100016-5	F100016-5	F100016-6	F100016-6	2	Ball

★ Items included in seal kit CDB40K1. ★★ Items included in seal kit CDB70K1.

REPAIR PARTS LIST					
Item	Model Number and Date Code Letter			Qty.	Description
	CDB180252 (O)	CDB180502 (O)	CDB280562 (O)		
1	PA1920005	PA1921005	—	1	Base (180kN)
	—	—	PA1923005	1	Base (280kN)
2	★ B1233203	★ B1233203	★★ B1238203	1	O-ring
3	PA2214044	PA2214044	—	1	Stop ring (180kN block)
	—	—	PA2215044	1	Stop ring (280kN block)
4	★ CY488041	★ CY488041	★★ DQ699041	1	Wiper
5	Part no longer available. See IMPORTANT on page 1.			1	Plunger
6	★ PA2176041	★ PA2176041	—	1	Rod seal (180kN)
	—	—	★★ PA2177041	1	Rod seal (280kN)
8	★ PA2544203	★ PA2544203	★★ PA2545203	1	O-ring
9	★ DA11612141	★ DA11612141	—	1	Glyd Ring (180kN)
	—	—	★★ DA11613141	1	Glyd Ring (280kN)
10	PA1845006	PA1845006	PA1845006	2	1/4 BSPP plug
11	★ PA1303167	★ PA1303167	★★ PA1303167	2	Copper gasket
12	CCA411028-1A	CCA411028-1A	CCA411028-1A	2	Socket head cap screw
13	★ B1110203	★ B1110203	★★ B1110203	2	O-ring
14	F100016-6	F100016-6	F100016-6	2	Ball (6mm)

★ Items included in seal kit CDB180K1. ★★ Items included in seal kit CDB280K1.

ENERPAC 

POWERFUL SOLUTIONS. GLOBAL FORCE.

www.enerpac.com