

L4180 Rev. F 07/21 EN

Table of Contents:

Section	Page
1.0 IMPORTANT RECEIVING INSTRUCTIONS	1
2.0 SAFETY	1
3.0 CONFORMANCE TO NATIONAL AND INTERNATIONAL STANDARDS	2
4.0 PRODUCT DESCRIPTION	2
5.0 HYDRAULIC SYSTEM	3
6.0 SETUP AND ASSEMBLY	7
7.0 INSTALLATION AND OPERATION	7
8.0 INSPECTION, MAINTENANCE & STORAGE	10
9.0 TROUBLESHOOTING	10
10.0 CAPACITIES	12
11.0 PRODUCT DATA	13



1.0 IMPORTANT RECEIVING INSTRUCTIONS

Visually inspect all components for shipping damage. Shipping damage is not covered by warranty. If shipping damage is found, notify carrier at once. The carrier is responsible for all repair and replacement costs resulting from damage in shipment.

2.0 SAFETY

2.1 Introduction

Read all instructions carefully. Follow all recommended safety precautions to avoid personal injury as well as damage to the product and/or damage to other property. Enerpac cannot be responsible for any damage or injury from unsafe use, lack of maintenance or incorrect operation. Do not remove warning labels, tags, or decals. In the event any questions or concerns arise, contact Enerpac or your local Enerpac distributor for clarification.

If you have never been trained on high-pressure hydraulic safety, consult your distributor or service center for information about an Enerpac Hydraulic Safety Course.

This manual follows a system of safety alert symbols, signal words and safety messages to warn the user of specific hazards. Failure to comply with these warnings could result in death or serious personal injury, as well as damage to the equipment or other property.



The **Safety Alert Symbol** appears throughout this manual. It is used to alert you to potential physical injury hazards. Pay close attention to Safety Alert Symbols and obey all safety messages that follow this symbol to avoid the possibility of death or serious personal injury.

Safety Alert Symbols are used in conjunction with certain Signal Words that call attention to safety messages or property damage messages and designate a degree or level of hazard seriousness. The Signal Words used in this manual are WARNING, CAUTION and NOTICE.



WARNING Indicates a hazardous situation that, if not avoided, **could** result in death or serious personal injury.



CAUTION Indicates a hazardous situation that, if not avoided, **could** result in minor or moderate personal injury.



NOTICE Indicates information considered important, but not hazard related (e.g. messages relating to property damage). Please note that the Safety Alert Symbol will **not** be used with this signal word.

2.2 Safety Precautions - Hydraulic Sync Grip Pullers



Failure to observe and comply with the following precautions could result in death or serious personal injury. Property damage could also occur.

- Read and completely understand the safety precautions and instructions in this manual before operating the puller or preparing it for use.
- Wear appropriate personal protective equipment (PPE) such as safety glasses and face shield. The operator must take precautions against injury due to flying debris caused by possible failure of the tool or workpiece.
- During operation, keep hands and fingers away from the work area to avoid personal injury.
- DO NOT use the puller in circumstances where a sudden release of hydraulic pressure could result in loss of balance, causing damage or injury.
- Never overload the puller or accessories. Never exceed puller maximum capacities or maximum allowable hydraulic working pressures. Refer to Sections 10.1 and 10.2 of this manual for detailed puller capacity information. Also observe and follow all operating precautions and pressure limits communicated in Section 7 of this manual.

- Be aware that puller capacity will vary, depending on the puller model, configuration and other variables. In some instances, the rated capacity of the puller may be less than the rated capacity of the hydraulic cylinder.
- Never attempt to pry the puller by inserting tools or other objects between the jaws. This may cause center bolt damage.
- Use hydraulic pressure gauges to verify proper operating pressure in the hydraulic system. Do NOT exceed maximum pressure limits of the lowest rated component in your system. Always use high pressure hoses and fittings.
- It is impossible to predict the exact force needed for every pulling situation. The amount of press fit and force of removal can vary greatly between jobs. Set-up requirements along with the size, shape and condition of the parts being pulled are variables which must be considered. Study each pulling application before you select your puller.
- Do not overload equipment. Use the correct size puller for your application. If you have applied maximum force, and the part still will not move, then use a larger capacity puller. Use of a sledge hammer to loosen parts is not recommended.
- Do not use puller if threads on adjusting rod, threaded collar or hydraulic cylinder are damaged or worn. Do not use puller if adjusting rod is bent.
- Do not over-extend the hydraulic cylinder. Do not operate the cylinder beyond the limits of its rated stroke.
- Apply force gradually. Align puller grip jaws as required. Be sure the setup is rigid and that puller is square with the work.
- Never use a puller that is damaged, altered or in need of repair.
- Always be sure that the adjusting rod is loosened and hydraulic pressure is completely relieved before performing any puller adjustment or repair procedures. Never service the puller while it is installed and under tension.
- Always read, understand and follow all safety precautions and instructions, including those that are contained within the procedures of this manual.

2.3 Additional Hydraulic Safety Precautions



Failure to observe and comply with the following precautions could result in death or serious personal injury. Property damage could also occur.

- Do not remove or disable the pump relief valve. Never set the relief valve to a higher pressure than the maximum rated pressure of the pump.
- The puller hydraulic cylinder is designed for a maximum pressure of 10,150 psi [700 bar]. Do not connect a pump with a higher pressure rating to the cylinder.
- To avoid personal injury and equipment damage, make sure all hydraulic components are rated for at least 10,150 psi [700 bar] working pressure.
- The system operating pressure must not exceed the pressure rating of the lowest rated component in the system. Install pressure gauge(s) in the system to monitor operating pressure. It is your window to see what is happening in the system.
- Make sure that all system components are protected from external sources of damage, such as excessive heat, flame, moving machine parts, sharp edges and corrosive chemicals.
- Do not handle pressurized hoses. Escaping oil under pressure can penetrate the skin. If oil is injected under the skin, see a doctor immediately.
- Always do a visual inspection of the puller and puller hydraulic system before placing it into operation. If any problems are

found, do not use the puller. Have the equipment repaired and tested before it is returned to service.

- Never use a hydraulic cylinder that is leaking oil. Do not use a cylinder that is damaged, altered or in need of repair.
- Do not loosen plugs, relief valves or any other hydraulic components unless hydraulic pressure is completely relieved.
- Always be sure that hydraulic pressure is fully relieved before disconnecting hydraulic hoses, loosening hydraulic couplers, or performing any cylinder disassembly or repair procedures.
- Always read, understand and follow all safety precautions and instructions, including those that are contained within the procedures of this manual.



Failure to observe and comply with the following precautions could result in minor or moderate personal injury. Property damage could also occur.

- Avoid damaging hydraulic hose. Avoid sharp bends and kinks when routing hydraulic hoses. Using a bent or kinked hose will cause severe back-pressure. Sharp bends and kinks will internally damage the hose, leading to premature hose failure.
- Do not drop heavy objects on hose. A sharp impact may cause internal damage to hose wire strands. Applying pressure to a damaged hose may cause it to rupture.
- Do not lift hydraulic equipment by the hoses or swivel couplers. Use the carrying handle or strap.
- Keep hydraulic equipment away from flames and heat. Excessive heat will soften packings and seals, resulting in fluid leaks. Heat also weakens hose materials and packings. For optimum performance, do not expose equipment to temperatures of 150°F [65°C] or higher. Protect all hydraulic equipment from weld spatter.
- Immediately replace worn or damaged parts with genuine Enerpac parts. Enerpac parts are designed to fit properly and to withstand high loads. Non-Enerpac parts may break or cause the product to malfunction.



- Hydraulic equipment must only be serviced by a qualified hydraulic technician. For repair service, contact the Enerpac Authorized Service Center in your area.
- To help ensure proper operation and best performance, use of Enerpac oil is strongly recommended.

3.0 CONFORMANCE TO NATIONAL AND INTERNATIONAL STANDARDS

 Enerpac declares that this product has been tested and conforms to applicable standards and is compatible with all CE Requirements. A copy of an EU Declaration of Incorporation is enclosed with each shipment of this product.

4.0 PRODUCT DESCRIPTION

4.1 Sync Grip Hydraulic Puller (SGH-Series)

The Sync Grip hydraulic puller can be used to remove and install gears, bearings and pulleys.

Four different puller models in a variety of capacities are available. Refer to the documentation provided with your shipment for model numbers and additional product data.

The Sync Grip puller's synchronized closing system means that all jaws move in unison, reducing the chance of damage to the puller components and making the puller easier and safer to use.

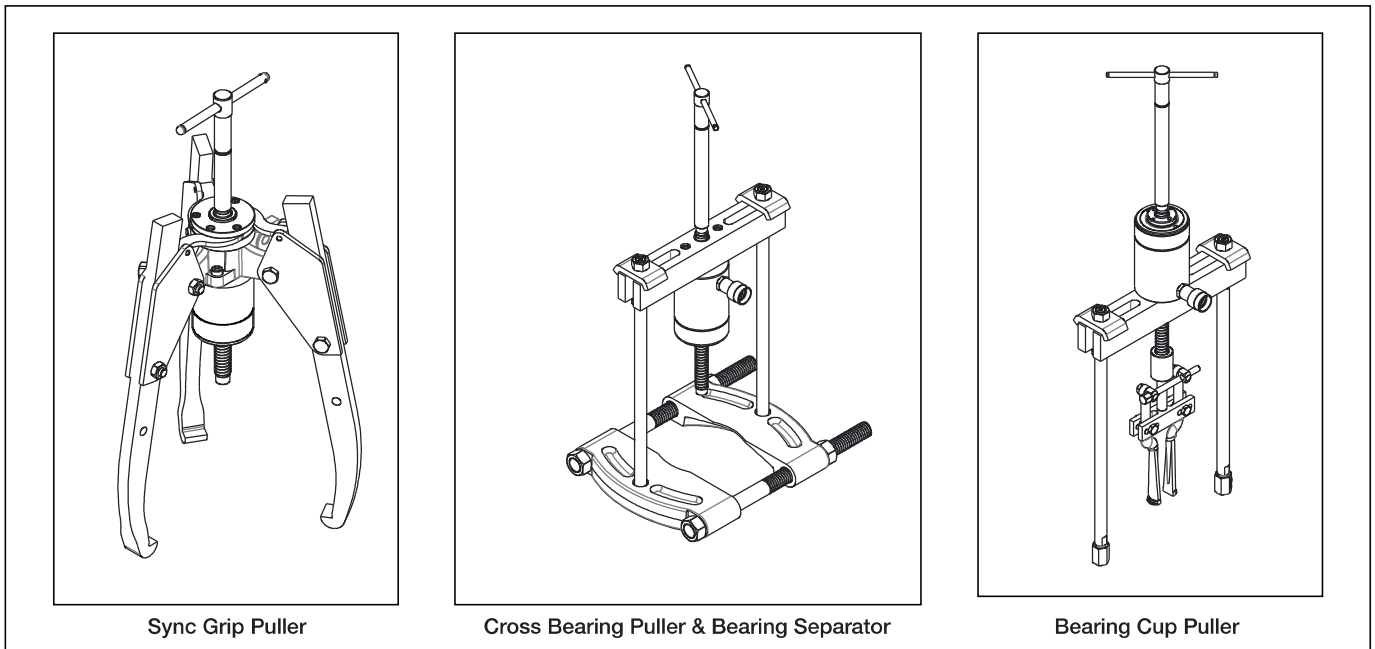

Figure 1, Hydraulic Puller Configurations (Typical)

4.2 Sync Grip Puller Set (GPS-Series)

The Enerpac Sync Grip Puller Set includes the following items:

- Sync Grip hydraulic grip puller (SGH-Series).
- Hydraulic pump, electric, air, battery or hand operated.
- Hydraulic hose, 6 feet [1.8 m] long.
- Hydraulic pressure gauge and gauge adapter.
- Hydraulic cylinder with coupler.

The specific items included in the Sync Grip Puller Set will vary, depending on the puller size and the pump type ordered.

4.3 Master Puller Set (MPS-Series)

The Enerpac Master Puller Set includes all the items of the Sync Grip Puller Set plus the following additional items:

- Bearing Cup Puller Attachment
- Cross Bearing Puller Components
- Bearing Separator Attachment
- Mounting and attaching hardware

These attachments allow the puller to be configured as a bearing cup puller or as a cross style bearing puller. They are designed for work environments where clearance prevents a direct application of the puller jaws.

For these configurations, the grip puller jaws, puller body and self-centering mechanism are not used.

The specific items included in the Master Puller Set will vary, depending on the puller size and the pump type ordered.

NOTICE Sync Grip Puller Set and Master Puller Set not available for puller model SGH100.

5.0 HYDRAULIC SYSTEM

5.1 Hydraulic Component Requirements

All hydraulic components used with the puller, including pump, cylinder, pressure gauge, hoses and fittings must be rated for at least 10,150 psi [700 bar] maximum working pressure.

The pump must include a safety relief valve that opens if the maximum hydraulic working pressure of 10,150 psi [700 bar] is exceeded.

WARNING Pump safety relief valve must not be set higher than 10,150 psi [700 bar]. Failure to observe this

precaution could result in high pressure oil leaks and/or catastrophic failure. Serious personal injury or death could result.

Electric, air and battery powered pumps must also include a user-adjustable relief valve, allowing the user to adjust the maximum working pressure to the correct setting for the puller application. For some puller configurations and applications, this setting will be **less** than the pump safety relief valve setting.

This information is provided for users who may wish to use the puller with the existing hydraulic components in their shop facilities. All hydraulic components included in an Enerpac Sync Grip Puller Set or Master Puller Set will conform to the stated specifications and requirements.

5.2 Hydraulic Cylinder

The hydraulic cylinder is pre-assembled in the body of the Sync Grip puller. When needed, the cylinder can be removed from the Sync Grip puller for use with various Master Puller Set components.

Refer to the following table for hydraulic cylinder usage information:

Hydraulic Cylinder Usage Information				
Enerpac Cylinder Model No.	Sync Grip Puller Model No.	Master Puller Set Components		
		Cross Bearing Puller	Bearing Separator	Bearing Cup Puller
RWH121900	SGH14	BHP2772	BHP181	BHP180
RCH202	SGH24	BHP262	BHP282	BHP280
RCH302	SGH36	BHP362	BHP382	BHP380
RCH603	SGH64	BHP562	BHP582	BHP580
RCH1003	SGH100	N/A	N/A	N/A

Note: An Enerpac CR-400 coupler with dust cap is included for all cylinder models. One pair of swiveling lifting eyes is included with puller model SGH100 only. Replacement lifting eyes are sold separately and are not included with the RCH1003 cylinder. N/A = Not Available.

WARNING Use only the Enerpac cylinder specified for your puller model. Improper operation and/or catastrophic failure could occur if a different cylinder is used. Serious personal injury or death may result.

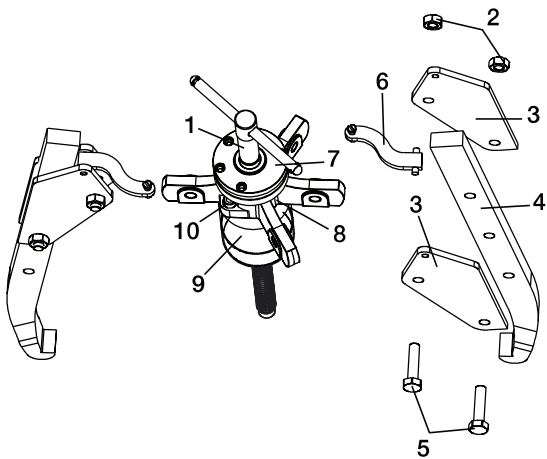
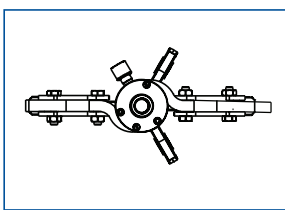

**Two-jaw Configuration
(Model SGH14)**

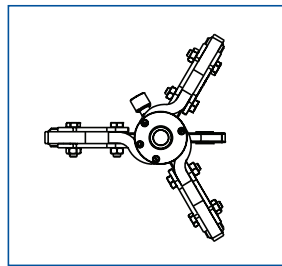
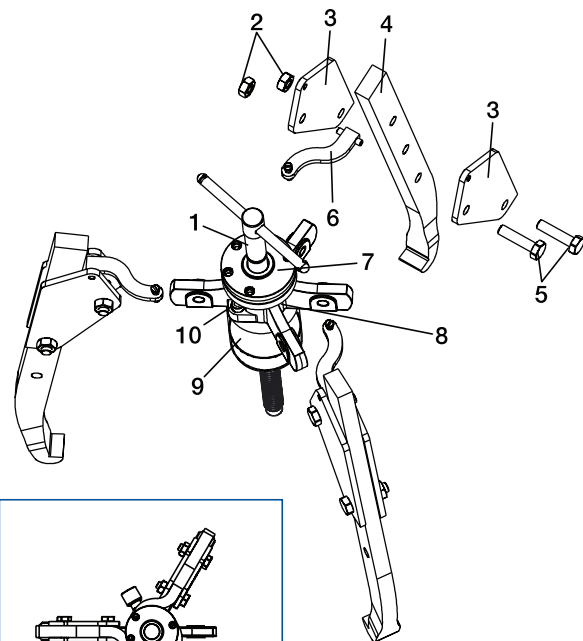

**Three-jaw Configuration
(Model SGH14)**

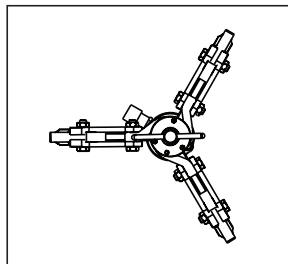
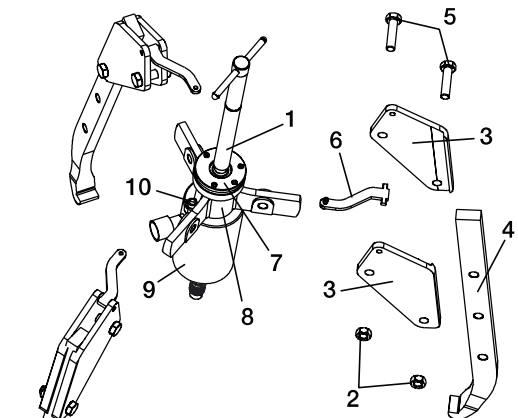

**Three-jaw Configuration
(Models SGH24, SGH36, SGH64 and SGH100)**

Key:

1. Adjusting Rod
2. Hex Nut
3. Plate
4. Jaw, Standard Length
Jaw, Extended Reach (optional)
5. Capscrew
6. Strap
7. Assembly, Self-Centering
8. Body
9. Hydraulic Cylinder
10. Mounting Screw

Note: Components shown in this figure are included with the GPS-Series Sync Grip Puller Set and the MPS-Series Master Puller Set.

Extended reach "long" jaws are an optional accessory for all pullers except model SGH100.

Figure 2, Setup and Assembly - Sync Grip Puller

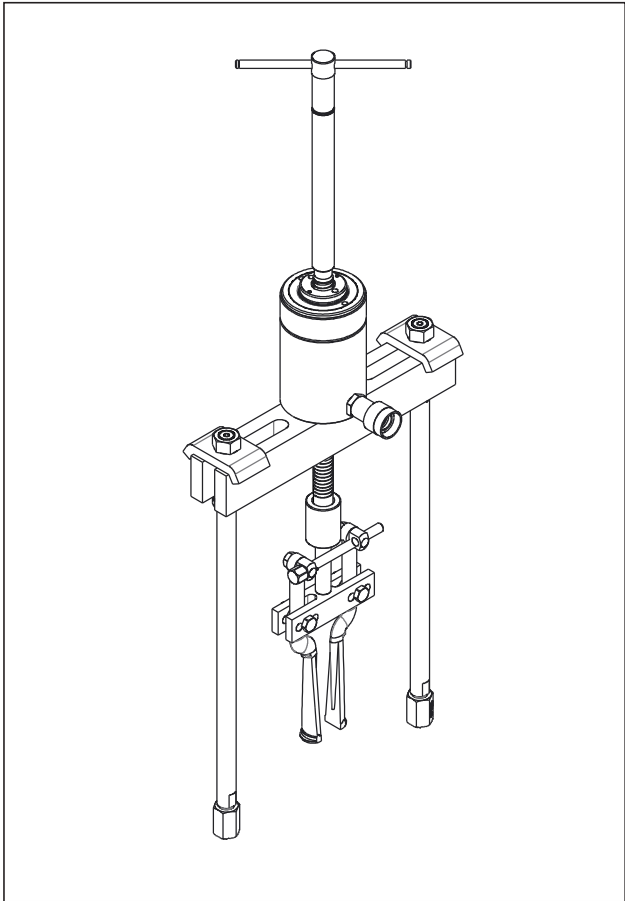
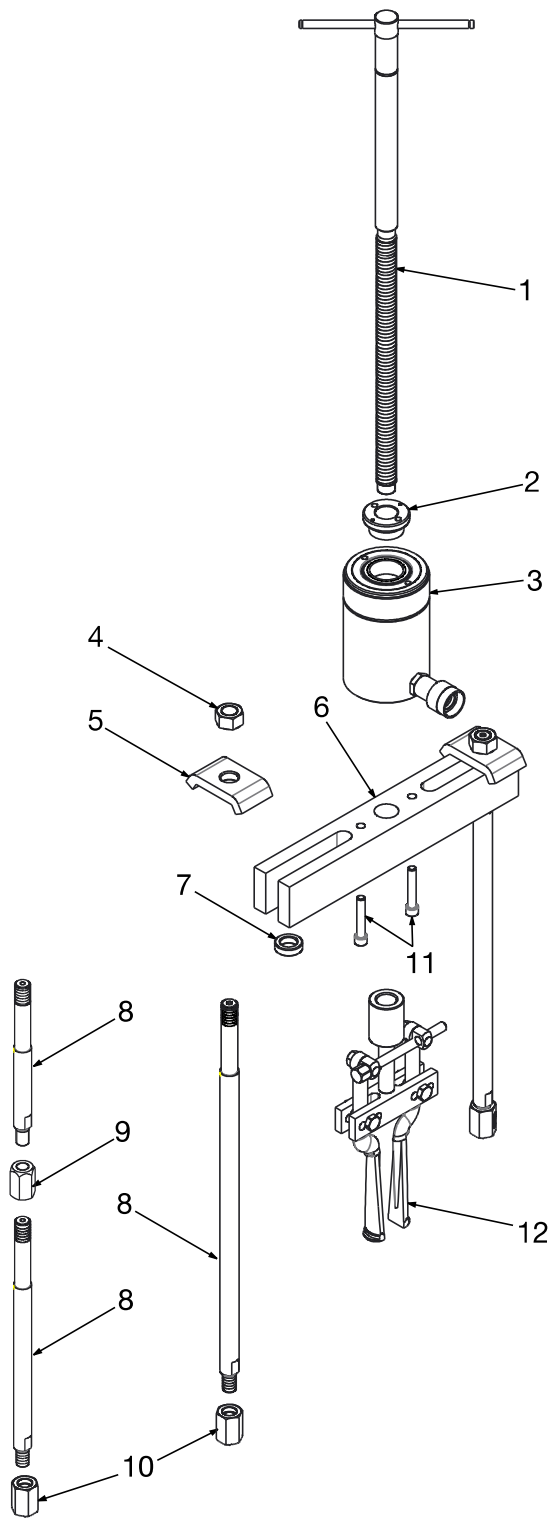

(Assembled View)

Key:

- 1. Adjusting Rod
- 2. Threaded Saddle
- 3. Hydraulic Cylinder
- 4. Hex Nut
- 5. Slide Plate
- 6. Slotted Crosshead
- 7. Leg Washer
- 8. Leg (various lengths)
- 9. Leg Reducer
- 10. Leg End
- 11. Mounting Screw
- 12. Internal Bearing Race Puller

Note: Components shown in this figure are included with the MPS-Series Master Puller Set.

Figure 3, Setup and Assembly - Bearing Cup Puller

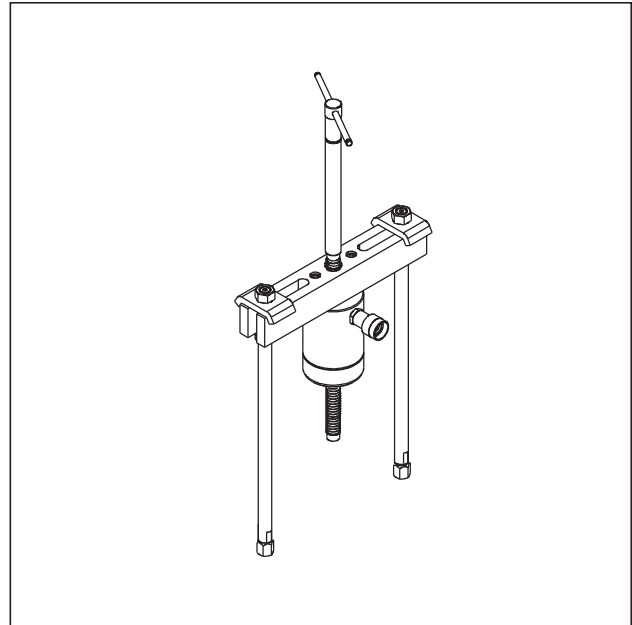
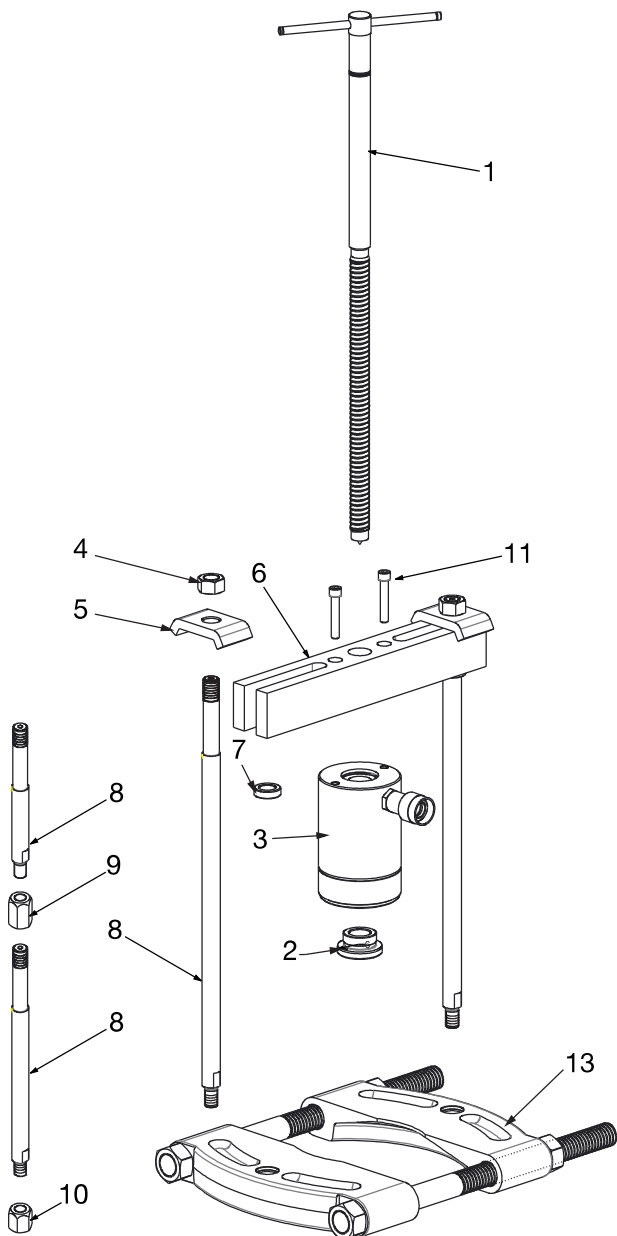

(Assembled View - Without Bearing Separator)

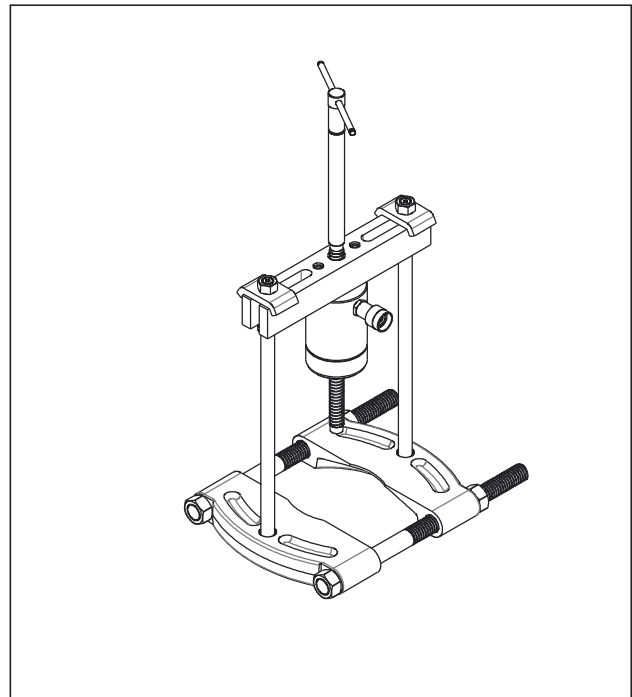

(Assembled View - With Bearing Separator)

Note: Components shown in this figure are included in the MPS-Series Master Puller Set.

Key:

- | | |
|-----------------------|----------------------------------|
| 1. Adjusting Rod | 7. Leg Washer |
| 2. Threaded Saddle | 8. Leg (various lengths) |
| 3. Hydraulic Cylinder | 9. Leg Reducer |
| 4. Hex Nut | 10. Leg End |
| 5. Slide Plate | 11. Mounting Screw |
| 6. Slotted Crosshead | 13. Bearing Separator Attachment |

Figure 4, Setup and Assembly - Cross Bearing Puller

5.3 Checking Oil Level

Check the oil level in the pump reservoir with the cylinder fully retracted. Add oil if level is low. Refer to the pump instruction sheet for detailed instructions and oil type.

Be sure to use a high quality hydraulic oil. Use of Enerpac oil is strongly recommended.

5.4 Advancing and Retracting the Cylinder

- **To advance:** Close the pump release valve. Operate the pump to build pressure and advance the cylinder.
- **To retract:** Open the pump release valve to release pressure and retract the cylinder.

For detailed hydraulic component operating instructions, refer to the instruction sheet included with the pump, hose, pressure gauge and hydraulic cylinder. Completely observe and follow all communicated instructions and safety precautions.

5.5 Air Removal

To remove trapped air from the hydraulic circuit, fully advance and retract the puller cylinder several times while it is not under load. If possible, position the cylinder so that it is lower than the pump reservoir. Avoid pressure build-up as the cylinder is being cycled. Air removal is complete when cylinder motion becomes smooth.

6.0 SETUP AND ASSEMBLY

6.1 Lifting Instructions

- Know the weight of the complete puller assembly, including puller, hydraulic cylinder and all attachments. Ensure that the lifting apparatus to be used is capable of supporting the total load.
- For pullers equipped with TWO pre-installed lifting eyes on the cylinder, always use BOTH lifting eyes when hoisting the puller.
- Lifting straps or chains must be positioned at an angle where they will not interfere with the cylinder base. Use of a spreader bar is recommended.
- Be careful when lifting the puller while it is in the vertical position, as the legs will close.
- If needed, support the puller with slings so that it can be used horizontally.
- When pulling horizontally, continue to support the puller so it does not drop. Secure the workpiece (bearing, sleeve, etc.) so that it does not slide or drop in an uncontrolled manner when it loosens from the shaft.
- When reorienting the puller from horizontal to the vertical position, incline the puller slowly and carefully.

6.2 Puller Configurations

The puller may be assembled in one of three different configurations:

- 1) Sync Grip Puller
- 2) Bearing Cup Puller
- 3) Cross Bearing Puller

Note that components required to assemble the bearing cup puller and cross bearing puller (items 2 and 3) are included only with the Master Puller Set.

Refer to figures 2, 3 and 4 for assembly details. Refer to the following sections of this manual for detailed operation instructions for each configuration.

6.3 Jaw Arrangement - Sync Grip Puller

Three standard length jaws are provided with the puller. Extended reach "long" jaws, are available as an optional accessory for all puller models.

Model SGH14 can be configured as either a two-jaw or three-jaw puller. The three-jaw configuration provides a more stable and secure grip, resulting in a more evenly distributed pulling force. For this reason, the three-jaw configuration should be used whenever possible.

Models SGH24, SGH36 and SGH64 can be assembled only in the three-jaw configuration.

7.0 INSTALLATION AND OPERATION

NOTICE Before operating any high force tool equipment, it is mandatory that the operator has a full understanding of all instructions and safety precautions included in this manual, and of all applicable local safety regulations and laws. If questions or concerns, contact the Enerpac Technical Service Department or your local Enerpac distributor.

7.1 Adjusting Rod Point Protector

All models feature a threaded adjusting rod with a tempered steel point.

A point protector is packed separately with all SGH-Series models. To prevent damage, the point protector **MUST** be used if the shaft end does not contain a drilled center hole or depression. See Figure 5.

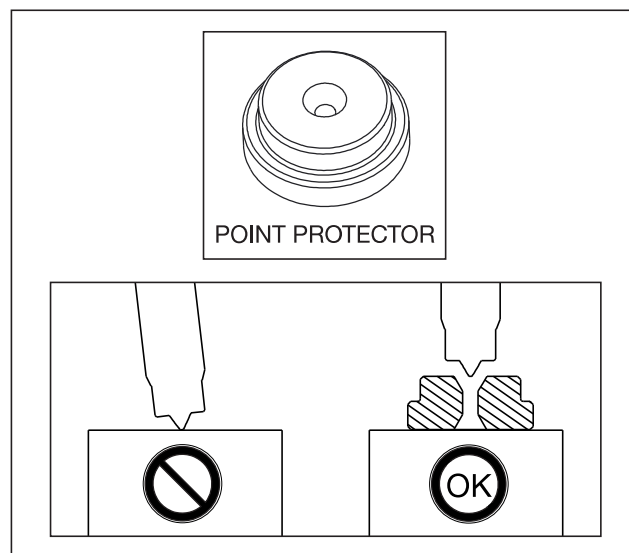

Figure 5, Point Protector

7.2 General Puller Use Instructions

- Be sure that the puller adjusting rod is cleaned and greased before use.
- Be sure that the jaws are properly centered on the item to be removed.
- Position the point of the adjusting rod into the center hole of the shaft or axle. If there is no center hole, use a point protector (included with all pullers).
- After mounting the puller on the part to be removed, be certain that the thread engagement indicator is visible. See Figure 6 for location. If the adjusting rod is turned clockwise too many turns, the indicator will be hidden, indicating that the amount of thread engagement is not sufficient.

WARNING

Do not operate the puller if the thread engagement indicator is not visible. Catastrophic failure could occur if the amount of thread engagement is not sufficient. Serious personal injury or death may result.

NOTICE If the thread engagement indicator is not visible, remove the puller and reinstall the jaws using the next lowest set of mounting holes.

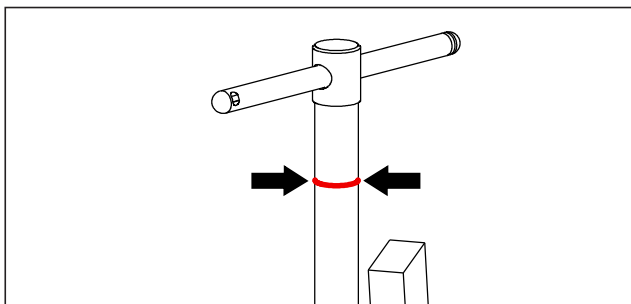

Figure 6, Thread engagement indicator (red band)

- To reduce the possibility of jaw deformation, always work with the jaws installed in the lowest possible mounting holes. Use the higher mounting holes only if necessary to provide clearance around large components. See Figure 7.

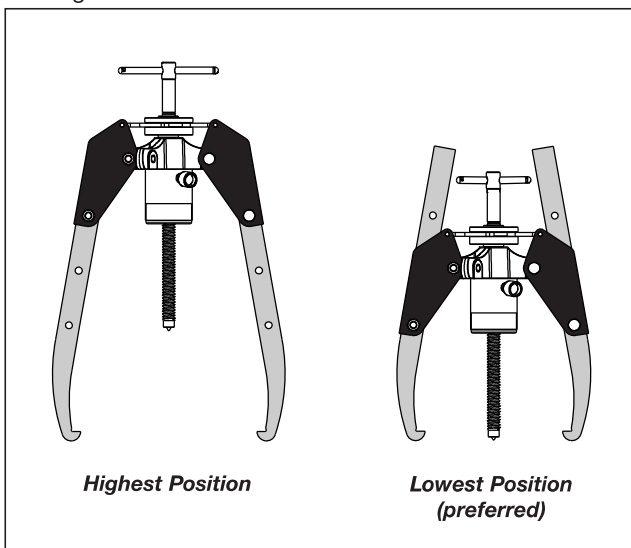

Figure 7, Jaw Mounting Positions (typical)

- Continuously monitor the hydraulic pressure gauge while operating the pump and puller. Stop the pump immediately if the maximum allowable hydraulic pressure for your puller model and configuration is reached.
- During operation, watch the puller for indications of jaw or adjusting rod deformation. See Figure 8. If any deformation is noticed, stop the pump immediately.
- In some applications, the amount of deformation may be so small that it is not noticeable. Never rely on visible deformation to determine the puller's safe operating limits. Always monitor the hydraulic pressure gauge.
- Work slowly when operating the puller in order to prevent any sudden or unexpected displacement of parts being removed.
- If needed, use a spacer of appropriate size to reduce the possibility of adjusting rod deformation. The spacer should be a solid steel billet with flat ends and a diameter that is larger than that of the adjusting screw.

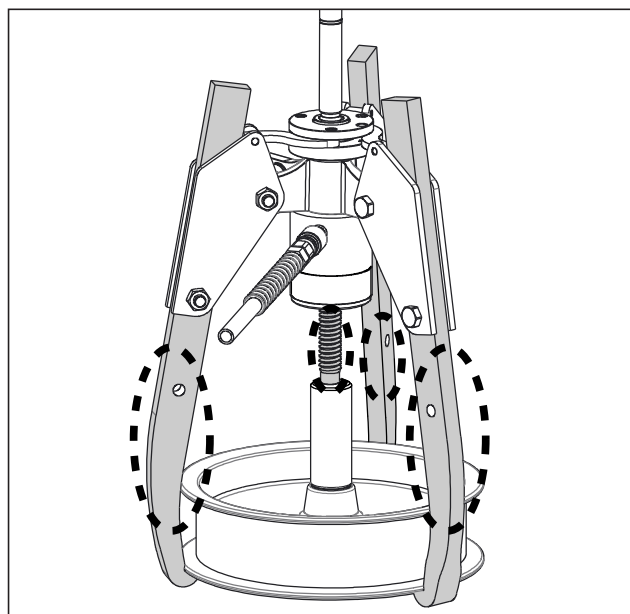

Figure 8, Checking for Deformation

7.3 Sync Grip Puller - Installation and Operation

- Assemble puller components as described in Figure 2. Refer to Section 6.2 for additional information.

NOTICE Model SGH14 can be configured as either a two or three-jaw puller. The three-jaw configuration is recommended because it provides the most even distribution of pulling force.

- Refer to sections 11.1 and 11.3 for additional jaw assembly details, specifications and dimensions.
- Install the puller on the pulley or other part to be removed. See Figure 9 for examples.
- Read and understand the following hydraulic pressure warning statements before proceeding. Also refer to Section 10.1 of this manual for additional related information.

⚠ WARNING

Models SGH14, SGH24 and SGH36:

Do not exceed 5,076 psi [350 bar] when using Sync Grip puller model SGH14 in the two-jaw configuration.

Do not exceed 10,150 psi [700 bar] when using Sync Grip puller model SGH14 in the three-jaw configuration.

Do not exceed 10,150 psi [700 bar] when using Sync Grip puller models SGH24, SGH36 and SGH100.

Overloading and catastrophic failure could occur if the stated maximum pressure limit for your puller model and configuration is exceeded. Serious personal injury or death may result.

⚠ WARNING

MODEL SGH64 Only:

Do not exceed 7,850 psi [540 bar] when using Sync Grip puller model SGH64.

Overloading and catastrophic failure could occur if this maximum pressure limit is exceeded. Serious personal injury or death may result.

Be aware that for model SGH64, the puller maximum rated capacity is approximately 25 percent less than the cylinder maximum rated capacity. For this reason, use extreme care to avoid exceeding the 7,850 psi [540 bar] pressure limit during puller operation.

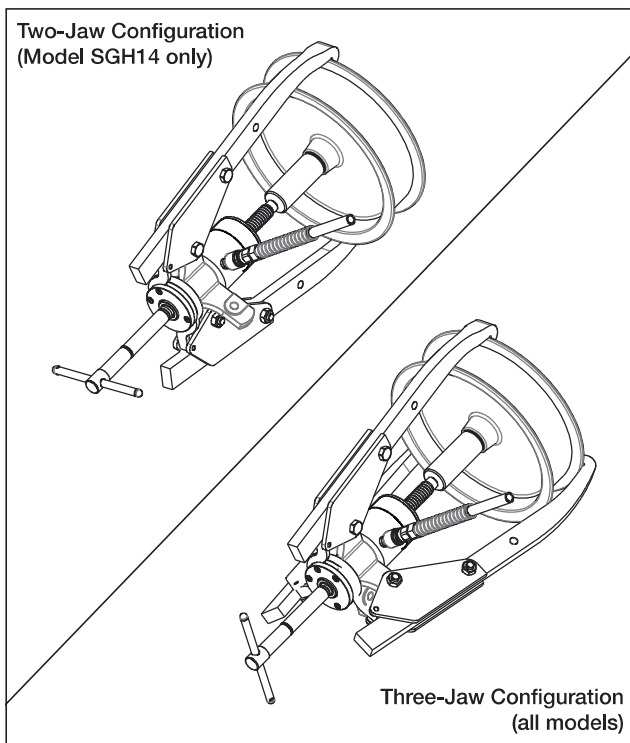

Figure 9, Pulley Removal (typical)

- Connect pump and hose to the puller hydraulic cylinder. Be sure that a pressure gauge is installed in the circuit.
- Gradually apply hydraulic pressure to remove the part. Continuously monitor the pressure gauge to avoid exceeding the allowable maximum working pressure for your setup.

7.4 Cross Bearing Puller - Installation and Operation (optional accessory, models SGH14, SGH24, SGH36 & SGH64 only)

- Assemble puller components as described in Figure 4.
- Install the puller on the bearing, pulley or other item to be removed. Align puller legs. See Figure 10.
- If needed for your application, install the bearing separator attachment. Refer to Section 7.5.
- Read and understand the following warning statement before proceeding. Also refer to Section 10.2 of this manual for important maximum hydraulic working pressure information.

⚠ WARNING

Do not exceed the stated maximum hydraulic working pressure for the cross bearing puller model being used.

Refer to Section 10.2 of this manual for the maximum hydraulic working pressure applicable to your cross bearing puller model. Be aware that the cross bearing puller is rated at a *lower* maximum capacity than the hydraulic cylinder.

Overloading and catastrophic failure could occur if the stated maximum pressure limit is exceeded. Serious personal injury or death may result.

- Connect pump and hose to the puller hydraulic cylinder. Be sure that a pressure gauge is installed in the circuit.
- Gradually apply hydraulic pressure to remove the part. Continuously monitor the pressure gauge to avoid exceeding the allowable maximum working pressure for your setup.

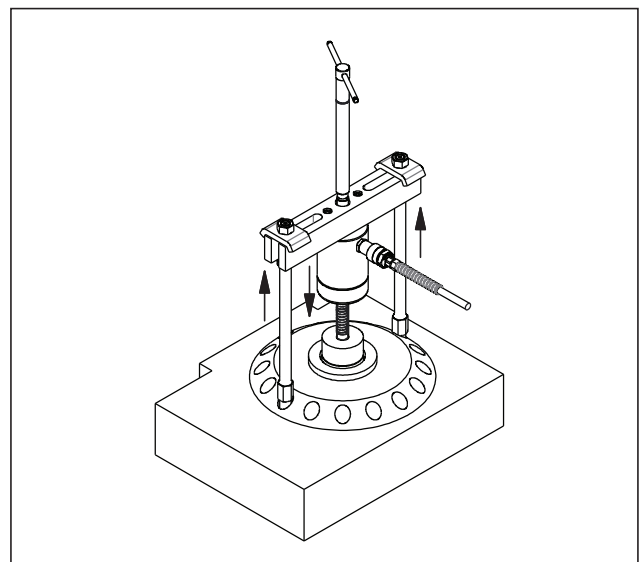

Figure 10, Cross Bearing Puller (typical)

7.5 Bearing Separator Attachment (optional accessory, models SGH14, SGH24, SGH36 & SGH64 only)

In situations where limited work room prevents a direct application of the grip puller jaws, the bearing separator attachment can be used in combination with the cross bearing puller.

The bearing separator attachment contains wedge shaped edges, allowing it to be more easily positioned behind a difficult-to-reach bearing, pulley or other shaft-mounted component. It has two halves, each containing a “flat” side and a “recessed” side.

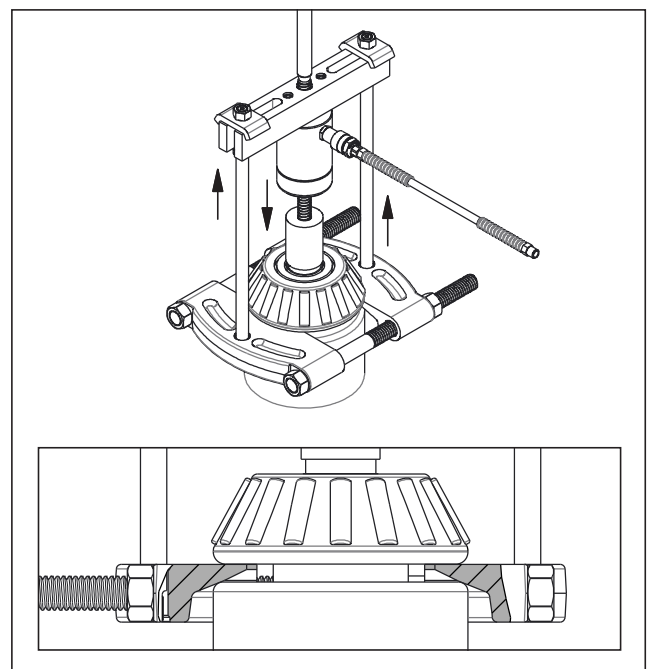

Figure 11, Bearing Separator Attachment - “A” Orientation (typical)

Whenever possible, it is recommended that the attachment be installed in the “A” orientation, as shown in Figure 11, so that the *flat* side of each separator half is positioned against the part to be removed. This will help spread the load over a greater surface area, reducing the possibility of deformation.

However, for applications where work room is especially limited, it may be necessary to begin the pulling process with the attachment installed in the “B” orientation, as shown

in Figure 12. In this orientation, the *recessed* side of each separator half is positioned against the part to be removed.

After the part has been moved a sufficient distance on the shaft, the attachment should be reinstalled in the “A” orientation. The removal process can then be fully completed.

When using the bearing separator attachment, follow the instructions and precautions contained in Section 7.4 of this manual. Also refer to Section 10.2 for maximum rated capacities and related information.

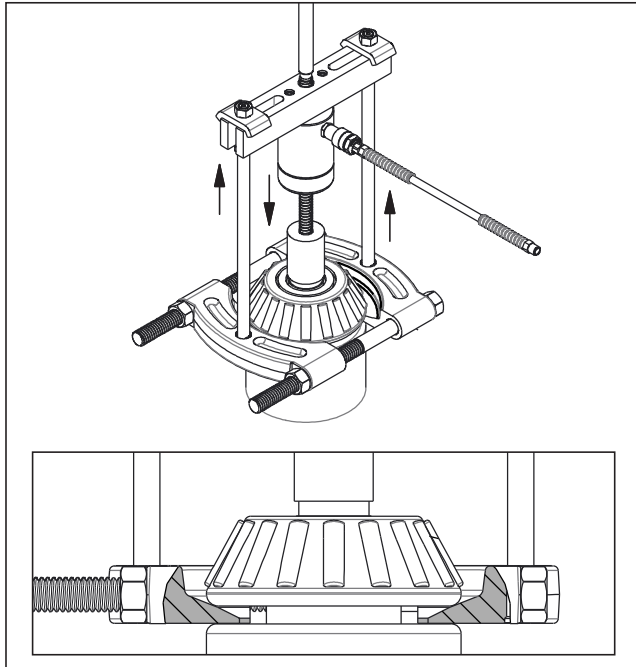

Figure 12, Bearing Separator Attachment - “B” Orientation (typical)

7.6 Bearing Cup Puller - Installation and Operation (optional accessory, models SGH14, SGH24, SGH36 & SGH64 only)

- Assemble puller components as shown in Figure 3.
- Install the puller on the bearing to be removed. Align puller legs and bearing cup puller jaws. See Figure 12.
- Read and understand the following warning statement before proceeding. Also refer to Section 10.2 of this manual for important maximum hydraulic working pressure information.

⚠ WARNING

Do not exceed the stated maximum hydraulic working pressure for the bearing cup puller model being used.

Refer to Section 10.2 of this manual for the maximum hydraulic working pressure applicable to your bearing cup puller model. Be aware that the bearing cup puller is rated at a lower maximum capacity than the hydraulic cylinder.

Overloading and catastrophic failure could occur if the stated maximum pressure limit is exceeded. Serious personal injury or death may result.

- Connect pump and hose to the puller hydraulic cylinder. Be sure that a pressure gauge is installed in the circuit.
- Gradually apply hydraulic pressure to remove the bearing. Continuously monitor the pressure gauge to avoid exceeding the allowable maximum working pressure for your setup.

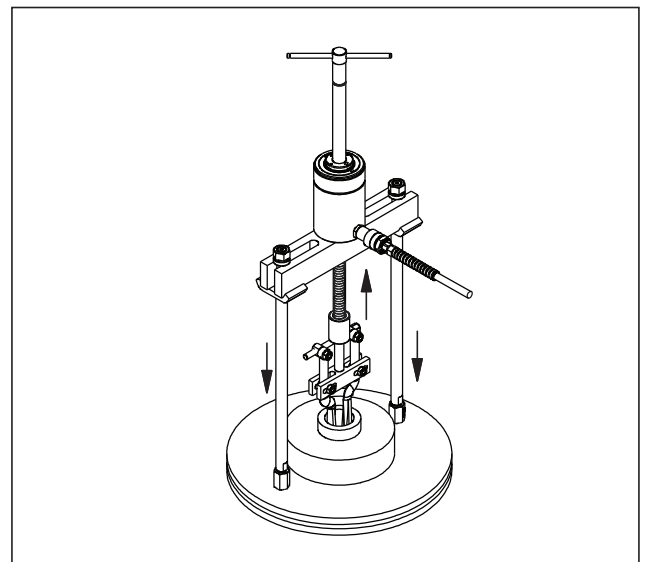

Figure 12, Cross Bearing Puller with Bearing Cup Attachment (typical)

8.0 INSPECTION, MAINTENANCE & STORAGE

Maintenance is required when wear or leakage is noticed. Periodically inspect all components to detect any problem requiring maintenance or service.

- Periodically check the hydraulic system for loose connections, leaks and other obvious problems. Replace any damaged components immediately.
- Monitor the oil temperature during operation. Do not exceed oil temperatures of 140°F [60°C].
- Keep all hydraulic components clean.
- Keep the puller in good condition. Clean and lubricate the puller’s adjusting rod and puller legs frequently, from thread to tip, to ensure good operation and long life.
- Change the hydraulic oil in your system as recommended in the pump instruction sheet. Use of Enerpac oil is strongly recommended.
- Periodically check the puller for any bent, loose, worn or deformed components. Make repairs as required before using the puller.
- Store the puller in a clean, dry and secure location. Keep stored hydraulic cylinders and hoses away from heat and direct sunlight.
- If the puller requires repairs, refer to the Enerpac website for the repair parts sheet applicable to your puller model.

NOTICE Hydraulic equipment must only be serviced by a qualified hydraulic technician. For repair service, contact the Enerpac Authorized Service Center in your area.

9.0 TROUBLESHOOTING

Refer to the troubleshooting guide (see next page) when diagnosing puller operational problems. Please note that the troubleshooting guide is not all-inclusive, and should be considered only as an aid to help diagnose the most commonly anticipated problems.

For repair service, contact your nearest Enerpac Authorized Service Center. As required, also refer to the troubleshooting information provided with the hydraulic pump and cylinder.

Troubleshooting Guide, SGH-Series Sync Grip Pullers

Puller Mechanical Troubleshooting

Symptom	Possible Cause	Solution
1. Jaws do not move freely or are difficult to move.	Self-centering mechanism corroded or seized.	Inspect self-centering mechanism. If corroded or seized, apply penetrating oil. Dismantle and clean mechanism as required.
2. One jaw moves independently.	Self-centering strap damaged or broken.	Replace self-centering strap. Replace complete self-centering mechanism if needed.
3. Adjusting rod will not turn or requires excessive effort to turn.	a. Corroded threads on adjusting rod, cylinder or threaded saddle.	If parts are seized, apply penetrating oil. Inspect threads on adjusting rod, cylinder and threaded saddle. Dismantle and clean components as required.
	b. Worn or damaged threads.	Replace adjusting rod, hydraulic cylinder and/or threaded saddle as required. Do not use puller if threads are worn or damaged.
	c. Adjusting rod is bent.	Replace adjusting rod. Do not use puller if adjusting rod is bent.

Hydraulic System Troubleshooting

Symptom	Possible Cause	Solution
1. Cylinder will not advance.	a. Pump release valve open.	Close pump release valve.
	b. Pump oil level is low.	Add oil to pump reservoir as required.
	c. Air in hydraulic system.	Remove air from hydraulic system. Refer to Section 5.5.
	d. Couplers not fully tightened.	Tighten couplers.
	e. Blocked hydraulic hose.	Repair or replace hydraulic hose.
	f. Pump malfunctioning.	Repair or replace pump as required.
	g. Cylinder seals leaking.	Repair or replace cylinder.
2. Cylinder advances only part way.	a. Pump oil level is low.	Add oil to pump reservoir as required.
	b. Couplers not fully tightened.	Tighten couplers.
	c. Cylinder plunger binding.	Repair or replace cylinder.
3. Cylinder advances erratically.	a. Air in hydraulic system.	Remove air from hydraulic system. Refer to Section 5.5.
	b. Cylinder plunger binding.	Repair or replace cylinder.
4. Cylinder advances more slowly than normal.	a. Leaking connection.	Repair leaking connection.
	b. Couplers not fully tightened.	Tighten couplers.
	c. Pump malfunctioning.	Repair or replace pump as required.
5. Cylinder advances, but will not hold.	a. Cylinder seals leaking.	Repair or replace cylinder.
	b. Leaking or loose connection.	Repair leaking connection.
	c. Pump malfunction.	Repair or replace pump.
6. Cylinder leaks oil.	a. Leaking or loose connection.	Repair leaking connection.
	b. Worn or damaged cylinder plunger.	Repair or replace cylinder.
	c. Internal leakage.	Repair or replace cylinder.
7. Cylinder will not retract or retracts more slowly than normal.	a. Pump release valve closed.	Open pump release valve.
	b. Coupler not fully tightened.	Tighten coupler.
	c. Pump reservoir is overfilled.	Drain oil from pump reservoir as required.
	d. Blocked hydraulic hose.	Repair or replace hydraulic hose.
	e. Internal cylinder damage.	Repair or replace cylinder.

10.0 CAPACITIES

10.1 Maximum Rated Capacity Information - Grip Pullers

Grip Puller Model No.	Hyd. Cylinder Model No.	Quantity of Jaws Installed	Grip Puller Maximum Rated Capacity		Cylinder Maximum Rated Capacity		Maximum allowable hydraulic working pressure when cylinder is installed on grip puller:	
			US Tons	kN	US Tons	kN	psi	bar
SGH14	RWH121900	2	7.0	75	14.0	125	5,076	350
	RWH121900	3	14.0	125	14.0	125	10,150	700
SGH24	RCH202	3	24.0	214	24.0	214	10,150	700
SGH36	RCH302	3	36.7	326	36.7	326	10,150	700
SGH64	RCH603	3	50.0	445	64.6	575	7,850	540
SGH100	RCH1003	3	103.0	931	103	931	10,150	700

NOTES:

- Model SGH14: Grip puller maximum rated capacity is **reduced by 50 percent** when used in the two-jaw configuration.
- Model SGH64: Grip puller maximum rated capacity is **approximately 25 percent less** than the cylinder maximum rated capacity.

10.2 Maximum Rated Capacity Information - Puller Accessories

Accessory Description	Accessory Model Number	Hyd. Cylinder Model No.	Accessory Maximum Rated Capacity		Cylinder Maximum Rated Capacity		Maximum allowable hydraulic working pressure when cylinder is used with accessory:	
			US Tons	kN	US Tons	kN	psi	bar
Cross Bearing Puller Set	BHP2772	RWH121900	7.0	75	14.0	125	5,076	350
	BHP262	RCH202	12.0	107	24.0	214	5,076	350
	BHP362	RCH302	18.3	163	36.7	326	5,076	350
	BHP562	RCH603	25.0	222	64.6	575	3,925	271
Bearing Separator Attachment	BHP181	RWH121900	7.0	75	14.0	125	5,076	350
	BHP282	RCH202	12.0	107	24.0	214	5,076	350
	BHP382	RCH302	18.3	163	36.7	326	5,076	350
	BHP582	RCH603	25.0	222	64.6	575	3,925	271
Bearing Cup Puller Attachment	BHP180	RWH121900	7.0	75	14.0	125	5,076	350
	BHP280	RCH202	12.0	107	24.0	214	5,076	350
	BHP380	RCH302	18.3	163	36.7	326	5,076	350
	BHP580	RCH603	25.0	222	64.6	575	3,925	271

NOTES:

- Accessories used with cylinder models RWH121900, RCH202 and RCH302: The maximum rated capacity of the accessory item is **50 percent less** than the cylinder maximum rated capacity.
- Accessories used with cylinder model RCH603: The maximum rated capacity of the accessory item is **approximately 60 percent less** than the cylinder maximum rated capacity.



Do not exceed the stated maximum hydraulic working pressure for the puller or accessory being used. Refer to the information contained in Sections 10.1 and 10.2.

Overloading and catastrophic failure could occur if the stated maximum pressure is exceeded. Serious personal injury or death may result.

Be aware that in some instances, the rated maximum capacity of the puller or accessory may be LESS than the rated maximum capacity of the cylinder, and that hydraulic pressure must be reduced accordingly.

11.0 PRODUCT DATA

11.1 Specifications and Dimensions - Grip Puller Reach, Spread and Weights

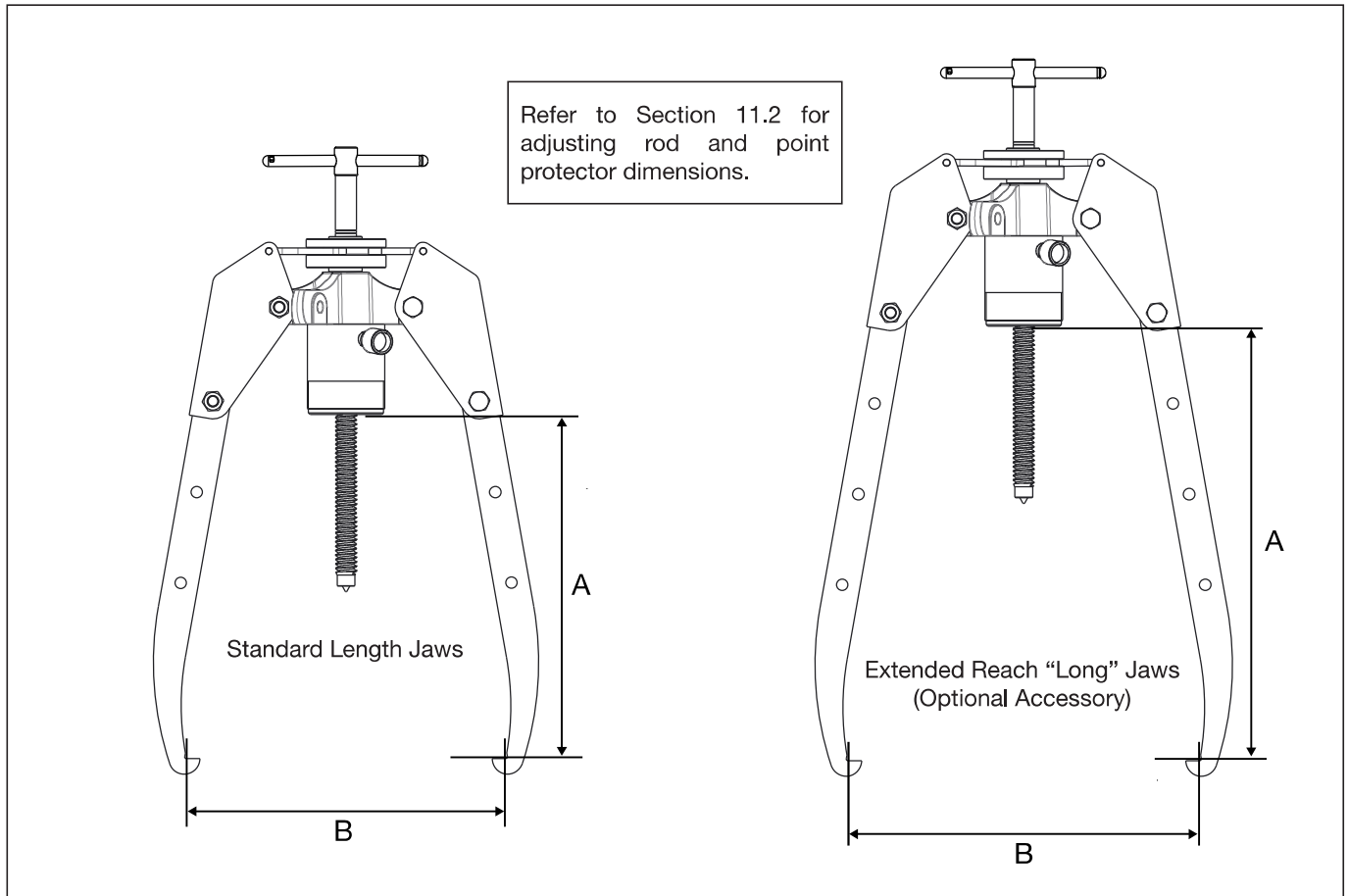

Grip Puller Model No.	Jaw Length	Maximum Reach		Maximum Spread		Weight *	
		A		B		lb	Kg
		in	mm	in	mm		
SGH14	Std.	12.60	320	13.78	350	55.1	25
	Long	15.75	400	15.94	405	59.5	27
SGH24	Std.	12.60	320	18.90	480	108.0	49
	Long	17.13	435	21.26	540	114.6	52
SGH36	Std.	16.14	410	25.59	650	165.3	75
	Long	20.67	525	28.35	720	178.5	81
SGH64	Std.	27.56	700	38.58	980	268.9	122
	Long	33.46	850	42.52	1,080	288.8	131
SGH100	Std.	39.37	1,000	63.00	1,600	842	322

* Approximate weight of assembled puller, including body, adjusting rod, jaws and hydraulic cylinder.

11.2 Specifications and Dimensions - Adjusting Rod and Point Protector

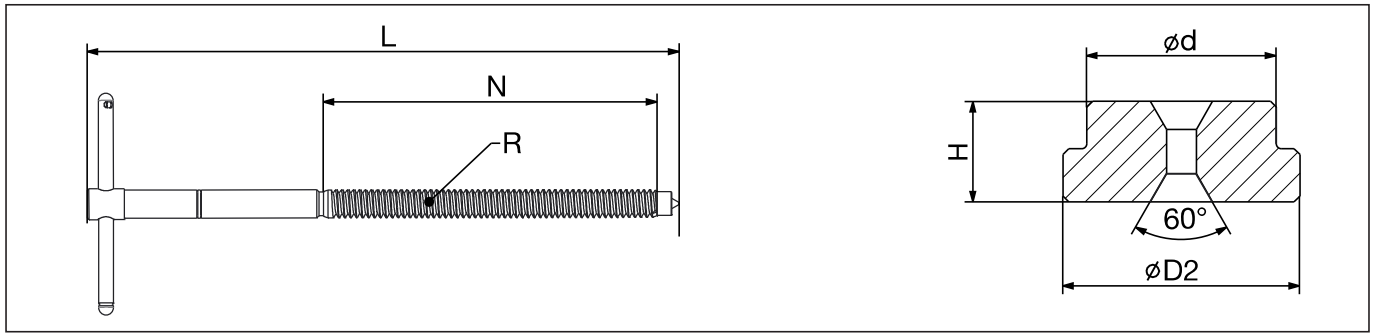

Used with Grip Puller Model No.	Total Length		Thread Length		Thread Size	Diameter				Height	
	L		N		R	d		D		H	
	in	mm	in	mm		in	mm	in	mm	in	mm
SGH14	15.75	400	8.74	222	3/4" - 16 UNF	0.83	21.0	1.50	38	0.65	16.5
SGH24	26.38	670	13.70	348	1" - 8 UNC	1.26	32.0	1.57	40	0.67	17
SGH36	31.10	790	16.81	427	1-1/4" - 7 UNC	1.50	38.0	1.73	44	0.71	18
SGH64	38.39	975	20.87	530	1-5/8" - 5.5 UNS	1.50	38.0	1.73	44	0.71	18
SGH100	39.09	993	22.17	563	2-1/2" - 8 UNC	1.77	45.0	2.17	55	1.18	30

11.3 Specifications and Dimensions - Grip Puller Jaws

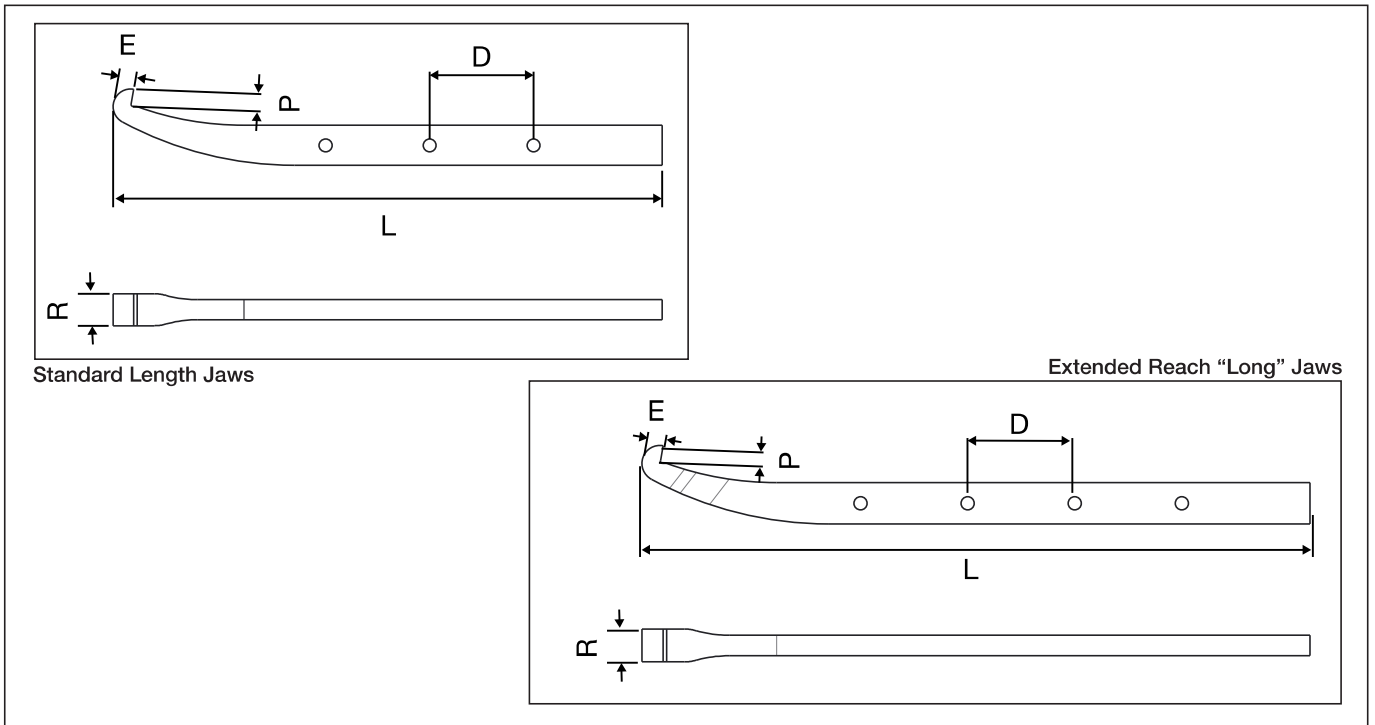

Used with Grip Puller Model No.	Jaw Length	End Surface		Width		Total Thickness		Length		Distance Between Holes	
		P		R		E		L		D	
		in	mm	in	mm	in	mm	in	mm	in	mm
SGH14	Std.	0.59	15.0	0.98	25.0	0.49	12.5	17.17	436	3.27	83
	Long	0.59	15.0	0.98	25.0	0.49	12.5	20.31	516	3.27	83
SGH24	Std.	0.69	17.5	1.22	31.0	0.61	15.5	21.65	550	4.53	115
	Long	0.69	17.5	1.22	31.0	0.61	15.5	26.18	665	4.53	115
SGH36	Std.	0.94	24.0	1.61	41.0	0.87	22.0	27.48	698	4.92	125
	Long	0.94	24.0	1.61	41.0	0.87	22.0	32.40	823	4.92	125
SGH64	Std.	1.06	27.0	1.97	50.0	1.18	30.0	41.73	1,060	5.91	150
	Long	1.06	27.0	1.97	50.0	1.18	30.0	47.64	1,210	5.91	150
SGH100	Std.	1.94	49.0	2.76	70.0	1.79	46.0	54.13	1,375	9.84	250

11.4 Specifications and Dimensions - Bearing Cup Puller Attachment

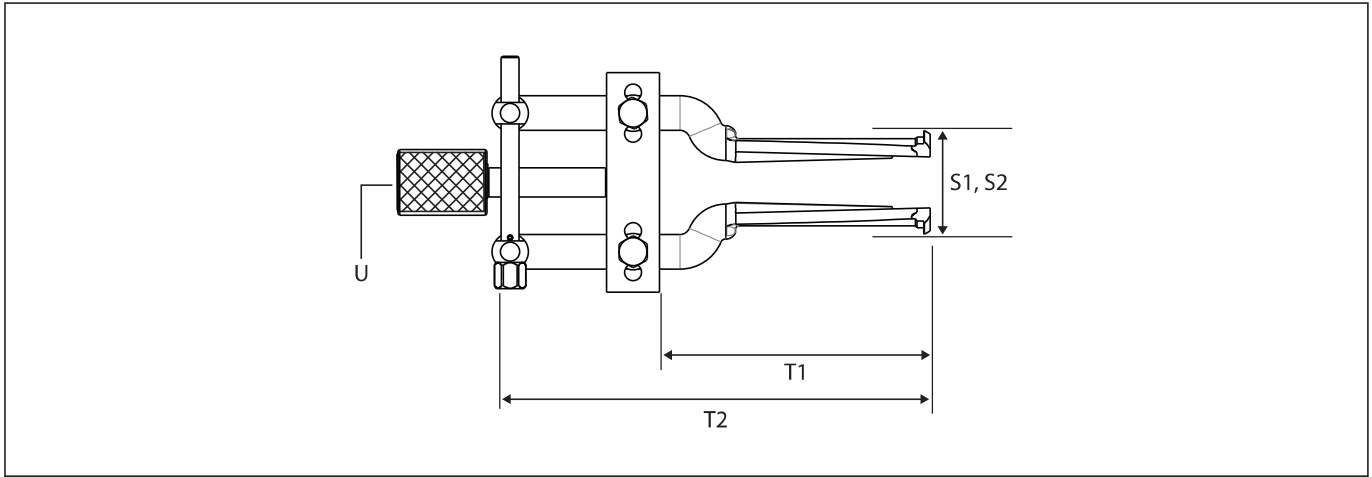

Bearing Cup Puller Attachment Model	Used with Enerpac Master Puller Set	Spread Min.		Spread Max.		Length				Thread Size	Weight	
		S1		S2		T		T2		U	lb	Kg
		in	mm	in	mm	in	mm	in	mm			
BHP180	MPS14	1.6	40	5.7	145	4.5	115	9.3	237	3/4" -16 UNF	4.4	2.0
BHP280	MPS24	1.3	32	6.3	160	5.5	140	10.5	266	1" - 8 UNF	5.3	2.4
BHP380	MPS36	2.4	60	9.4	240	5.9	150	12.2	310	1-1/4" - 7 UNC	13.2	6.0
BHP580	MPS64	2.4	60	9.4	240	5.9	150	12.2	310	1-5/8" - 5.5 UNS	14.1	6.4

11.5 Specifications and Dimensions - Bearing Separator Attachment

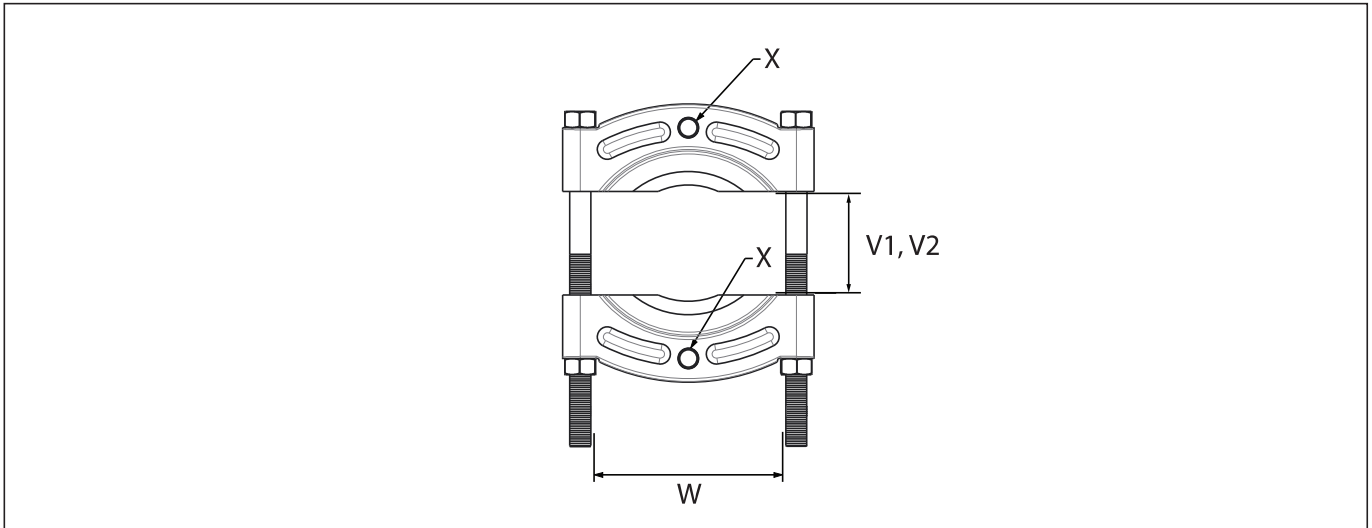

Bearing Separator Attachment Model	Used with Enerpac Master Puller Set	Spread Min.		Spread Max.		Width		Thread Size	Weight	
		V1		V2		W		X	lb	Kg
		in	mm	in	mm	in	mm			
BHP181	MPS14	0.39	10	4.33	110	4.33	110	5/8" - 18 UNF	6.0	2.7
BHP282	MPS24	0.47	12	5.28	134	6.10	155	5/8" - 18 UNF	12.6	5.7
BHP382	MPS36	0.67	17	9.84	250	10.24	260	1" - 14 UNS	62.8	28.5
BHP582	MPS64	0.67	17	9.84	250	10.24	260	1-1/4" - 12 UNF	62.8	28.5

