

Index:

English.....	1-2
Português.....	3-4
Polski.....	5-6

**To Protect Your Warranty,
Use Only ENERPAC Hydraulic Oil.**
Enerpac recommends that all kit components be installed
to insure optimum performance of the repaired product.

WARNING:

To ensure that the internal relief valve setting is correct, check the model number when servicing the product. The setting may require adjustment based on the pressure setting designated by the dash code (-XXXX) of the model number.

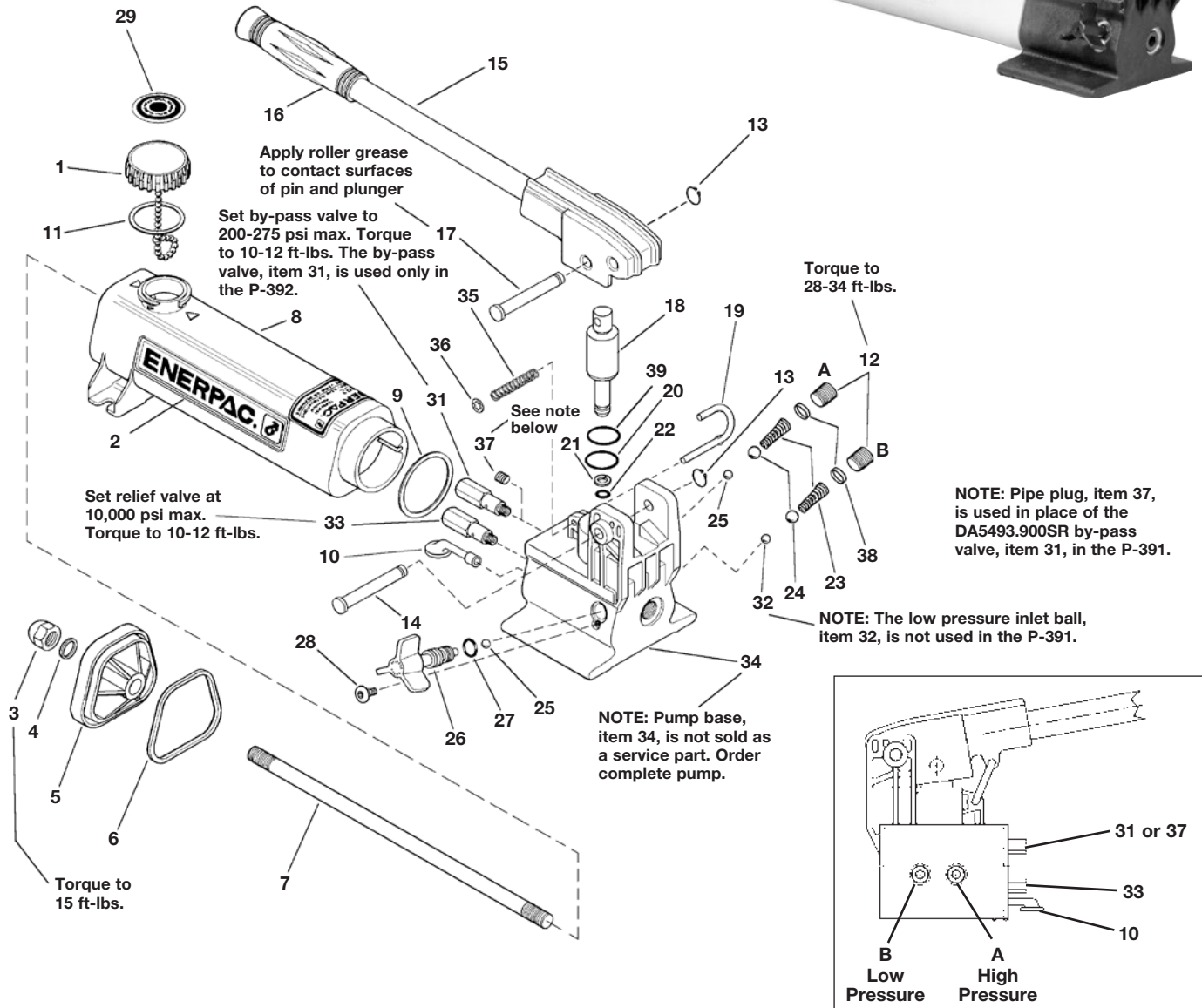

Repair Parts List for Figure 1

Item	Part No.	Qty.	Description	Item	Part No.	Qty.	Description
1	CN766950SR	1	Vent Cap Assembly (incl. item 11,29)	19	CM927061SR	1	Locking Pin (incl. item 35,36)
2	★	1	Enerpac Decal	20	★	1	O-Ring
3	CL341055	1	Acorn Nut	21	★	1	Back-Up Ring
4	★	1	Gasket	22	★	1	O-Ring
5	CN814020SR	1	End Cap (incl. item 3,4,6)	23	★	2	Spring
6	★	1	Gasket O-Ring	24	★	2	5/16" Ball
7	CL127149	1	Tie Rod	25	★	2	7/32" Ball
8	CR72025SR	1	Reservoir (yellow incl. item 2,3,4,6,9,11)	26	CL913900SR	1	Spindle Assembly (incl. item 25,27,28)
	S95032025	1	Reservoir (red incl. item 2,3,4,6,9,11)	27	★	1	O-Ring
9	★	1	Gasket	28	★	1	Screw
10	DA3729900SR	1	Oil Filter	29	★	1	Vent Cap Decal
11	★	1	Gasket	31	DA5493900SR	1	Bypass Valve (P392 Only)
12	CN815006	2	Pipe Plug	32	★	1	7/32" Inlet Check Ball (P392 Only)
13	★	2	Retaining Ring	33	DA8802900SR	1	Relief Valve
14	★CR214061SR	1	Beam Pin (incl. item 13)	34	Order complete pump	1	Base (not available as service item)
15	CL918900SR	1	Beam and Handle Assembly	35	★	1	Spring
16	CL343550	1	Handle Grip	36	★	1	Retaining Ring
17	DC106061SR1	1	Cross Pin	37	A1006245	1	Pipe Plug (P391 Only)
18	CR333040SR	1	Plunger Assembly (incl. item 13,17,21,22)	38	★	2	Spring Cap
				39	★	1	Wiper

★ Indicates items included in, and available only as part of Repair Kit P391K2

NOTE: Bypass Valve, Item 31, and Inlet Check Ball, Item 32, are not used in the single-speed P391 model pump.

Use Item 37 in place of Item 31.