

To Protect Your Warranty, Use Only ENERPAC Hydraulic Oil.

Enerpac recommends that all kit components be installed to insure optimum performance of the repaired product.

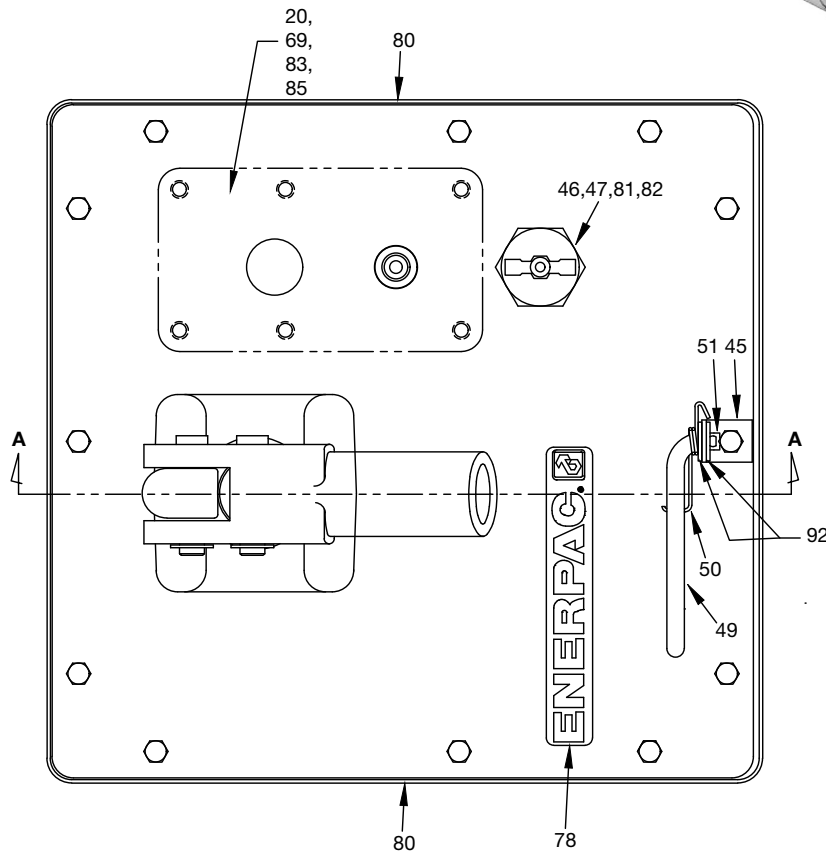

Figure 1

Repair Parts List for Figure 1

Item	Part Number	Qty.	Description	Item	Part Number	Qty.	Description
20	★	6	Copper Gasket	80	*	2	Enerpac Decal (not shown)
45	See item 49	1	Bracket	81	See item 47	1	Vent Plug
46	See item 47	1	O-Ring	82	*	1	Fill Decal
47	CA563024SR	1	Fill Plug (includes 46,81,82)	83	VM2	1	3W2P Valve Asm (P462)
49	CB546017SR	1	Hook (includes 51,45,50,92)		VM4		4W3P Valve Asm (P464)
50	See item 49	1	Spring		VM4L		Locking Valve (P464L)
51	See item 49	1	Cotter Pin 3/32 x 1/2	85	*	1	Valve Decal
69	★	1	Manifold Gasket, Foam	92	See item 49	2	5/16 Flat Washers
78	*	1	Decal				

★ Indicates items included in, and available ONLY as part of Repair Kit P462K3.

* Indicates items included in, and available ONLY as part of Pump Decal Kit P4642DS.

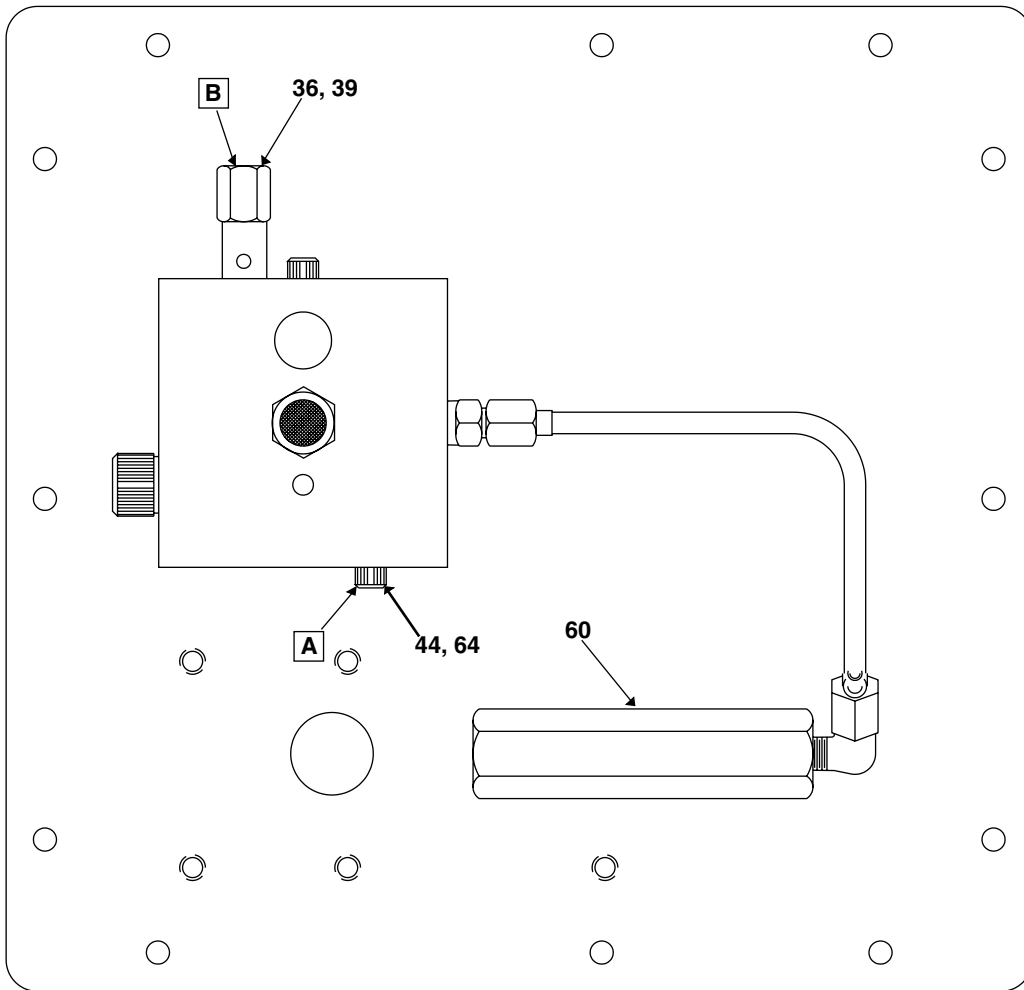

Figure 2

TORQUE SPECS AND RELIEF SETTINGS	
A	Torque item 64 to 7-9 ft.-lbs.
B	Set relief valve (item 39) to 10,800 psi max. Torque to 25-30 ft.-lbs.

Parts List - Figure 2			
Item	Part Number	Qty.	Description
36	★	1	Gasket
39	P181190W	1	Relief Valve (includes item 36)
44	★	1	Gasket
60	DA4885038	1	Adaptor
64	B1002028SR	1	Screw (includes Item 44)
★ Indicates items included in, and available ONLY as part of Repair Kit P462K3.			

TORQUE SPECS AND RELIEF SETTINGS

A	Torque item 33 to 25-30 ft-lbs.
B	Set relief valve (item 39) to 10,000-10,500 psi. Torque to 25-30 ft-lbs.
C	Torque tube nuts (item 43) to 50-150 in-lbs.
D	Torque item 25 to 50-70 ft-lbs.
E	Torque item 14 to 25-30 ft-lbs.
F	Drill out stake mark before removing. Apply Loctite #222 to threads of item 6 before assembling.
G	Torque item 52 to 60-65 in-lbs.
H	Apply Loctite #222 to threads of item 23 before assembling.

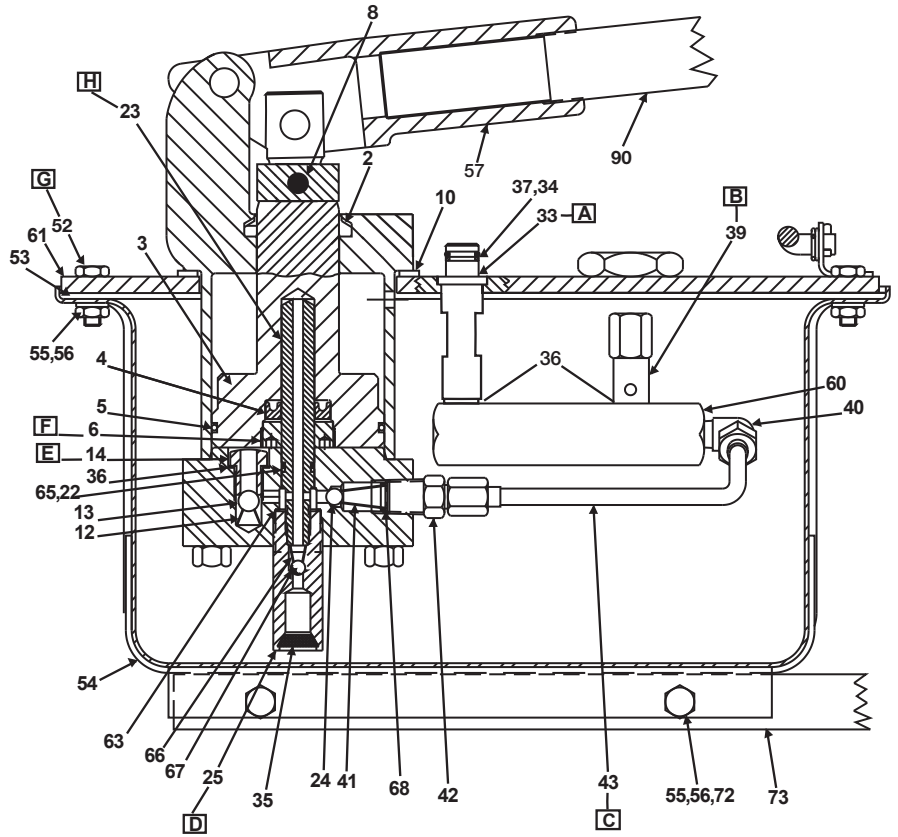

Figure 3

Repair Parts List for Figure 3

Item	Part Number	Qty.	Description	Item	Part Number	Qty.	Description
2	★	1	Wiper Ring	40	B202291	1	Elbow
3	DA4087051SR	1	Plunger Assy. (includes items 4,6,5,8)	41	★	1	Spring
4	★	1	U-Cup	42	CB548096SR	1	Connector (includes items 68,41,24)
5	★	1	O-Ring	43	Y524268	1	Tube
6	F20005	1	Retaining Nut	52	Standard hardware	12	Hex Bolt 1/4-20 NC x 3/4
8	★	1	Sleeve Protectors	53	★	1	Gasket
10	★	1	Gasket	54	CB519025SR	1	Reservoir (includes item 53)
12	★	1	Spring	55	Standard hardware	15	Lockwasher 1/4"
13	★	1	5/16" Ball	56	Standard hardware	15	Nut 1/4-20 NC
14	C596185SR	1	Valve Plug (includes items 36,13,12)	57	CB722060	1	Beam
22	★	1	O-Ring	60	DA4885038	1	Adaptor
23	DA4088051SR	1	Piston (includes items 63,22,65)	61	DA4887098SR	1	Coverplate (includes items 10,53)
24	★	1	1/4" Ball	63	★	1	Gasket
25	DA4109290SR ★	1	Inlet Seat (includes items 35,67,66,63)	65	★	1	Back-Up Washer
33	DA4889038SR	1	Adaptor (includes items 37,34,36)	66	★	1	Spring
34	★	1	Back-Up Washer	67	★	2	7/32" Ball
35	★	1	Filter	68	★	1	Spring Cap
36	★	3	Gasket	72	Standard hardware	4	Hex Bolt 1/4-20 NC x 1 3/4
37	★	1	O-Ring	73	CB550636	1	Pump Leg
39	P181190W	1	Relief Valve (includes item 36)	90	C397900W	1	Handle & Grip Assembly

★ Indicates items included in, and available ONLY as part of Repair Kit P462K3.

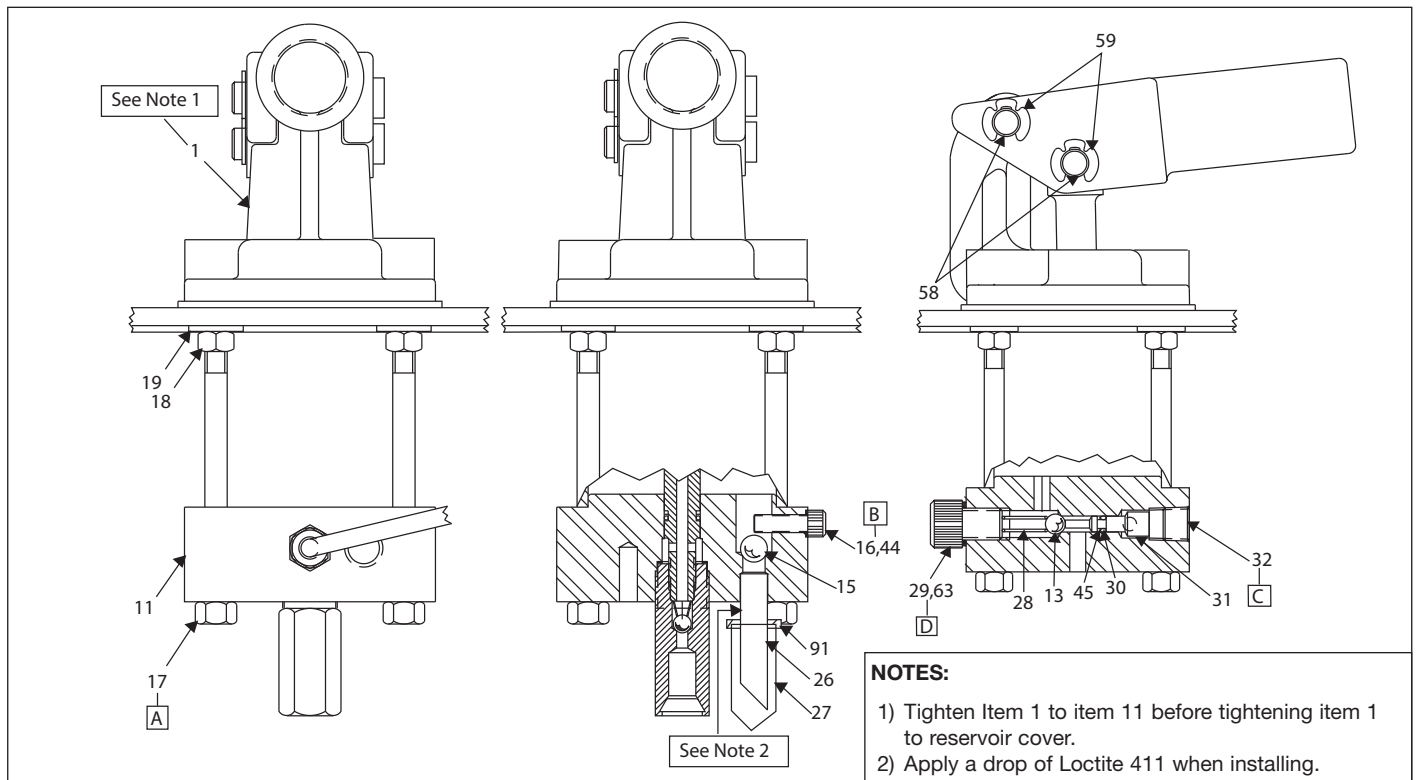

Figure 4

- NOTES:**
- 1) Tighten Item 1 to item 11 before tightening item 1 to reservoir cover.
 - 2) Apply a drop of Loctite 411 when installing.

TORQUE SPECIFICATIONS

A) Torque item 17 to 10-12 ft-lbs.	B) Torque item 16 to 7-9 ft-lbs.	C) Torque item 32 to 44-53 ft-lbs.	D) Torque item 29 to 25-30 ft-lbs.
------------------------------------	----------------------------------	------------------------------------	------------------------------------

Repair Parts List for Figure 4							
Item	Part Number	Qty.	Description	Item	Part Number	Qty.	Description
1	DA4840001	1	Housing	29	B1131028SR	1	Capscrew (includes items 13,28,63)
11	DA4098191	1	Pump Body	30	★	1	O-Ring
13	★	2	5/16" Ball	31	DA4108051SR	1	Piston (includes items 32,30,45)
15	★	1	3/8" Ball	32	A1008245	1	Plug
16	B1008028SR	1	Screw (includes item 44)	44	★	1	Gasket
17	DC230028	4	Socket Hd. Capscrew	45	★	1	Back-Up Washer
18	Standard hardware	4	Hex Nut 5/16-18 UNC	58	DA4888061SR	2	Beam Pin (includes item 59)
19	Standard hardware	4	Lockwasher 5/16"	59	★	2	Retaining Ring
26	DA4884268SR	1	Tube (includes items 27,91)	63	★	1	Gasket
27	★	1	Filter (see item 26)	91	★	1	Clamp (see item 26)
28	★	1	Spring				

★ Indicates items included in, and available only as part of Repair Kit P462K3.