

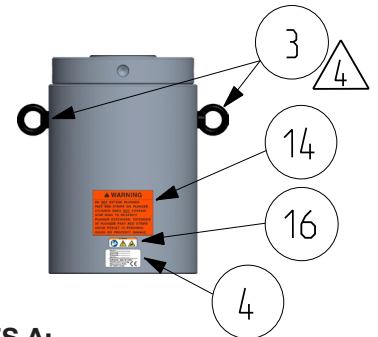

Repair Parts Sheet

RCL CYLINDERS, 30 TON MODELS

Parts Sheet Number	Revision	Revision Date	Product version
RRCL30	Rev. B	07/2020	A

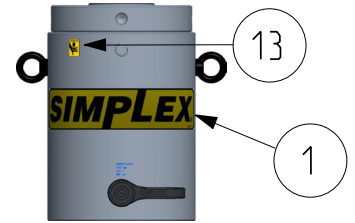
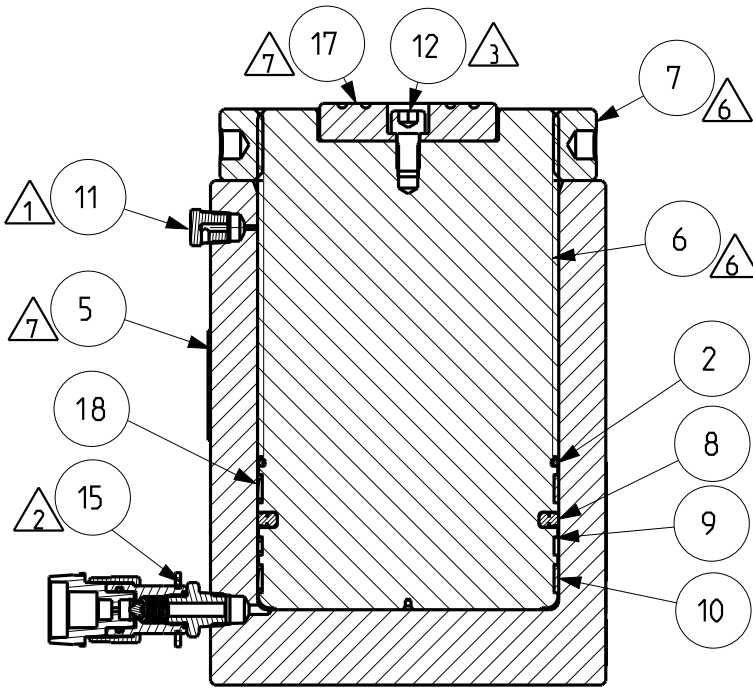

- ▲ = Indicated parts only available in Seal Kit RCL302K
- = Indicated parts only available in Seal Kit RCL306K
- = Indicated parts only available in Seal Kit RCL3012K

NOTES Δ:

- 1- Torque to 23-28 Ft-Lbs [32-38 Nm]
- 2- Torque to 40-60 Ft-Lbs [55-81 Nm]
- 3- Torque to 15-25 Ft-Lbs [20-34 Nm]
- 4- Torque to 40-50 In-Lbs [3.5-5.5 Nm]
- 6- Apply oil wax before assembly
- 7- Apply oil wax after assembly

Nr.	DESCRIPTION	QTY	RCL302	RCL306	RCL3012
1	Simplex Decal	1	▲	■	●
2	O-Ring	1	▲	■	●
3	Eyebolt Rotating	2	24D0205	24D0205	24D0205
4	Characteristics Decal	1	▲	■	●
5	Base	1	52L0457	52L0451	52L0449
6	Plunger	1	53M0447	53M0441	53M0439
7	Nut	1	55L0267	55L0267	55L0267
8	Piston Seal	1	▲	■	●
9	Glide Ring-Piston	1	-	■	●
10	Glide Ring-Piston	1	▲	■	●
11	Plug	1	BSS6348D	BSS6348D	BSS6348D
12	Screw-SHCS. HEX	1	CBE1221028-1A	CBE1221028-1A	CBE1221028-1A
13	Warning Decal	1	▲	■	●
14	Plunger Caution Warning Decal	1	▲	■	●
15	Female coupler	1	DB2771034	DB2771034	DB2771034
16	Caution Decal	1	▲	■	●
17	Saddle	1	HCR50045	HCR50045	HCR50045
18	Glide Ring-Piston	1	▲	■	●