

L4119

Rev. D

03/20

EN

Index:

English (EN)	1-6
Français (FR)	7-12
Deutsch (DE)	13-18
Italiano (IT)	19-24
Español (ES)	25-30
Nederlands (NL)	31-36
Português/Brasil (PT)	37-42
Suomi (FI)	43-48
Norsk (NO)	49-54
Svenska (SV)	55-60
简体中文 (ZH)	61-66
日本語 (JA)	67-72
한국어 (KO)	73-78
Русский (RU)	79-84
Polski (PL)	85-90
Eesti (ET)	91-96

1.0 DELIVERY INSTRUCTIONS

Upon delivery, all components must be inspected for damage incurred during shipping. If damage is found the carrier should be notified at once. Shipping damage is not covered by the Enerpac warranty.

2.0 SAFETY INSTRUCTIONS

Read all instructions carefully. Follow all recommended safety precautions to avoid personal injury as well as damage to the jack and/or damage to other property. Enerpac cannot be responsible for any damage or injury from unsafe use, lack of maintenance or incorrect operation. Do not remove warning labels, tags, or decals. In the event any questions or concerns arise, contact Enerpac or a local Enerpac distributor for clarification.

If you have never been trained on high-pressure hydraulic safety, consult your distributor or service center for a free Enerpac Hydraulic Safety Course.

This manual follows a system of safety alert symbols, signal words and safety messages to warn the user of specific hazards. Failure to comply with these warnings could result in death or serious personal injury, as well as damage to the equipment or other property.

 The Safety Alert Symbol appears throughout this manual. It is used to alert you to potential physical injury hazards. Pay close attention to Safety Alert Symbols and obey all safety messages that follow this symbol to avoid the possibility of death or serious personal injury.

Safety Alert Symbols are used in conjunction with certain Signal Words that call attention to safety messages or property damage messages and designate a degree or level of hazard seriousness. The Signal Words used in this manual are DANGER, WARNING, CAUTION and NOTICE.

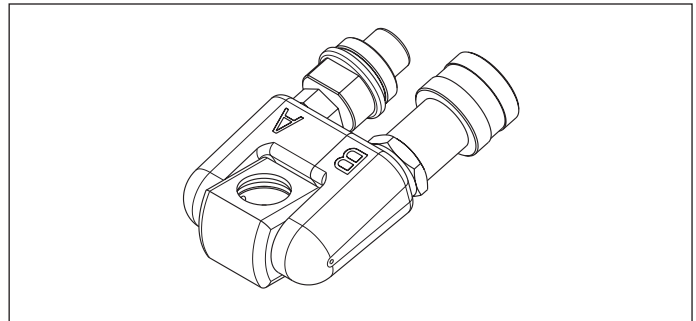

DANGER Indicates a hazardous situation that, if not avoided, will result in death or serious personal injury.

WARNING Indicates a hazardous situation that, if not avoided, could result in death or serious personal injury.

CAUTION Indicates a hazardous situation that, if not avoided, could result in minor or moderate personal injury.

NOTICE Indicates information considered important, but not hazard related (e.g. messages relating to property damage). Please note that the Safety Alert Symbol will not be used with this signal word.

3.0 INTRODUCTION

The TSP300 Pro Series Swivel is an optional accessory available for selected Enerpac torque wrenches. It is compatible with the following wrench and drive unit models:

S-Series Wrenches:	W-Series Drive Units:
• S1500X or S1500PX	• W2000X or W2000PX
• S3000X or S3000PX	• W4000X or W4000PX
• S6000X or S6000PX	• W8000X or W8000PX
• S11000X or S11000PX	• W15000X or W15000PX
• S25000X or S25000PX	• W22000X or W22000PX
	• W35000X or W35000PX

For S-Series wrenches, the swivel is mounted on the wrench housing.
For W-Series wrenches, the swivel is mounted on the drive unit housing.

The TSP300 Pro Series Swivel fits only S-Series wrenches or W-Series drive units which contain an "X" or "PX" suffix at the end of the model number.

If the wrench or drive unit is factory equipped with a pre-installed TSP300 swivel, the model number will end in "PX" instead of "X".

NOTICE Do not attempt to install a TSP300 swivel on an S-Series wrench or W-Series drive unit that does not contain an "X" or "PX" suffix at the end of the model number. The TSP300 is not compatible with these older product versions.

Two different swivel kits are available:

- Swivel kit model TSP300 includes a complete swivel assembly. New O-rings for the swivel manifold block and swivel post are also included. The existing swivel post is reused.

- Swivel kit model TSP300MK includes all items included with the TSP300 kit, plus a new swivel post, four retaining capscrews and two hydraulic port O-rings. This kit must be ordered if the existing swivel post is worn or damaged and requires replacement.

Hydraulic couplings are included with both swivel kits and are pre-installed at the factory prior to shipment.

⚠ WARNING Always completely relieve hydraulic pressure and disconnect both hydraulic hoses from the wrench before beginning any of the following procedures. Be certain that pressure gauge indicates zero (0) psi/bar. Unexpected release of hydraulic oil under pressure may occur if these precautions are not followed. Serious personal injury could result.

NOTICE

- Wipe all surfaces clean before beginning the following procedures. Take every precaution to prevent dirt from entering the wrench. Dirt entry may result in erratic wrench operation and/or damage to wrench.
- The following procedures are to be performed only by persons experienced in maintenance and repair of high pressure hydraulic equipment, using appropriate tools, personal protective equipment and shop facilities. Appropriate safety procedures are to be followed at all times.

4.0 INSTALLATION - TSP300 SWIVEL ASSEMBLY

Refer to Figures 1, 2 and 3 during the following steps. Discard old parts and replace with new parts from the kit as indicated.

- Remove the circlip retainer ring (A) from the top of the swivel post (F).
- Using a pair of flat blade screwdrivers, gently pry the old swivel assembly off of the swivel post (F).
- Inspect the swivel post (F) for obvious signs of wear or damage.

NOTICE

- If the old swivel post is in good condition, it can be reused. Continue with steps 4 through 9 of this procedure
- If old swivel post is worn or damaged, replace it as described in the instructions in Section 5.0. Then, continue with steps 4 through 9 of this procedure.
- Check that the four socket head capscrews (D) securing the swivel post are tight. See Section 5.0, step 6, for torque values.
- Remove the old O-ring (E) from the swivel post (F) and replace it with a new O-ring (E) from the kit. Coat the O-ring with silicone grease before installing. See Figure 2 for location.

NOTICE If O-rings (C) are pre-installed in the swivel manifold block (B8), skip step 6 and go to step 7.

- Install two new O-rings (C) from the kit into the grooves of the swivel manifold block. Coat the O-rings with silicone grease before installing. See Figure 3 for locations.
- After installation, coat all O-rings with a small amount of additional silicone grease. Carefully slide the new TSP swivel assembly (B) onto the swivel post (F).
- Install a new circlip retainer ring (A) from the kit onto the swivel post (F).
- Connect hydraulic hoses and cycle the wrench at 1,000 psi [69 bar] to check for oil leaks. If there are no leaks, cycle the wrench at 10,000 psi [690 bar] and check again for leaks.

Table 1, Parts List - Pro Series Swivel Kits TSP300 and TSP300MK (See Figures 1 through 5)				
Item Ref.	Qty	TSP300	TSP300MK	Description
A	1	◆	◆	Circlip Retaining Ring
B	1	◆	◆	Swivel Assembly (see items B1 - B9)
C	2	◆	◆	O-rings, Swivel Assembly
D	4	---	◆	Capscrew, Socket Head
E	1	◆	◆	O-ring, Swivel Post
F	1	---	◆	Swivel Post
G	2	---	◆	O-ring, Hydraulic Port
H	1	---	---	Drive Unit (W-Series) or Wrench Housing (S-Series)
B1	1	◆	◆	Hydraulic Coupling, Male
B2	1	◆	◆	Hydraulic Adapter
B3	1	◆	◆	Hydraulic Coupling, Female
B4	1	◆	◆	Swivel Arm "A"
B5	1	◆	◆	Swivel Arm "B"
B6	2	◆	◆	O-ring, Swivel Manifold
B7	2	◆	◆	O-ring, Swivel Arm
B8	1	◆	◆	Swivel Manifold Block
B9	1	◆	◆	Capscrew, Swivel Retaining Arms
NOTICE: Refer to the torque wrench repair parts sheet for part numbers.				

⚠ WARNING Pressurized hydraulic oil can penetrate the skin and could cause serious injury. Always repair any oil leaks before using the wrench.

5.0 INSTALLATION - TSP300 SWIVEL POST

Refer to Figures 1, 2 and 3 during the following steps.

- If not already done: Remove the circlip retainer ring (A) from the top of the swivel post (F). Using a pair of screwdrivers, gently pry the old swivel assembly (B) off of the swivel post (F).
- Remove the four socket head capscrews (D) securing the swivel post (F). Gently pry the swivel post (F) from the drive unit or wrench housing (H).
- Wipe clean all surfaces of the drive unit or wrench housing (H). Then, apply a small amount of Loctite 243 thread sealant in each of the four threaded bolt holes (*) in the drive unit or wrench housing (H). Be careful not to drip sealant into the hydraulic ports.
- Install two new O-rings (G) into the ports on the base of the new swivel post (F). See Figure 2 for O-ring locations.
- Place the new swivel post (F) on the drive unit or wrench housing (H), making sure that hydraulic ports are aligned. Be careful that O-rings (G) do not drop out or become pinched or cut.

NOTICE In the following step, be sure to use the new socket head capscrews (D) provided with the TSP300MK kit. Before installation, be certain that capscrews are clean, and free of oil or grease.

6. Install the four new socket head capscrews (D). Tighten them to the torque applicable to your wrench or drive unit model:
 - a. S1500X, S3000X, W2000X and W4000X Series Models: 3.7 Ft.lbs [5.1 Nm].
 - b. S6000X, S11000X, S25000X, W8000X and W15000X Series Models: 7.5 Ft.lbs [10.2 Nm].
 - c. W22000X and W35000X Series Models: 7.5 Ft.lbs [10.2 Nm].

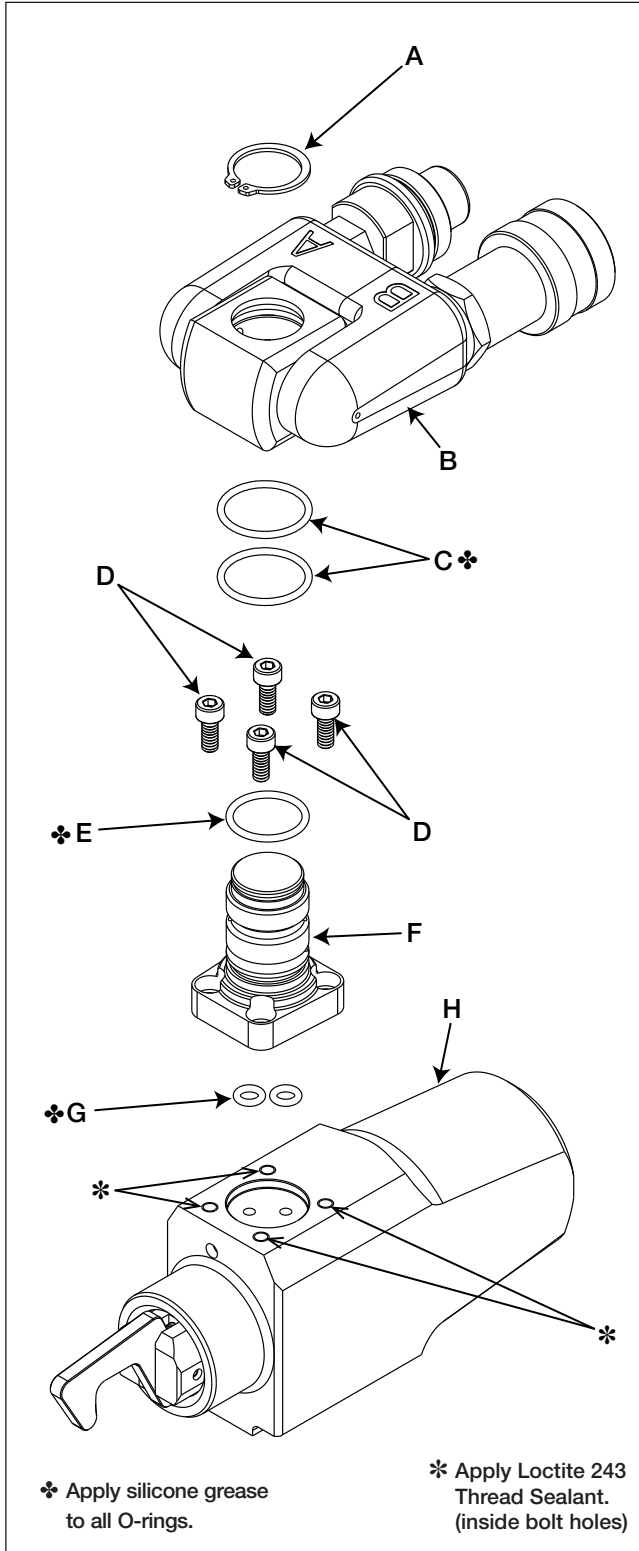

Figure 1, Exploded View - TSP300 Pro Series Swivel

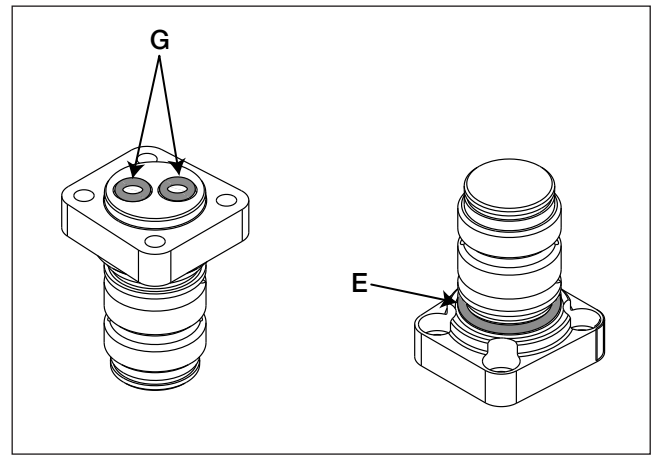

Figure 2, O-ring Installation, Swivel Post

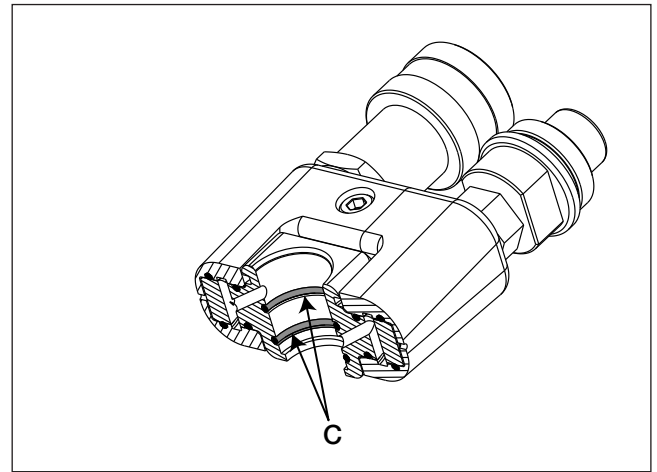

Figure 3, O-ring Installation - Swivel Manifold Block

7. Install the new swivel post O-ring (E) from the kit. Coat the O-ring with silicone grease before installing. See Figure 2 for location.
8. Install the TSP swivel onto the swivel post. Test for proper operation. Refer to steps 6 through 9 of Section 4.0 for instructions.

6.0 HYDRAULIC COUPLING REPLACEMENT

Replace the hydraulic couplings as described in the following steps: Refer to Figures 1 and 4.

1. Remove the circlip retainer ring (A) from the top of the swivel post (F).
2. Using a pair of screwdrivers, gently pry the swivel assembly (B) off of the swivel post (F).

NOTICE Use a vise with soft jaws to hold the swivel when removing and installing hydraulic fittings in the following steps. To prevent possible damage to wrench, never attempt to tighten the hydraulic fittings while the swivel is installed on the wrench.

3. Place the swivel assembly in a vise with soft jaws, and remove the old male coupling (B1), adapter (B2) and female coupling (B3).
4. In preparation for reinstallation, remove any deposits of dried thread sealant remaining on the threads of the swivel assembly (B).

NOTICE Inspect all components before reassembly. Always replace any worn or damaged parts with new ones.

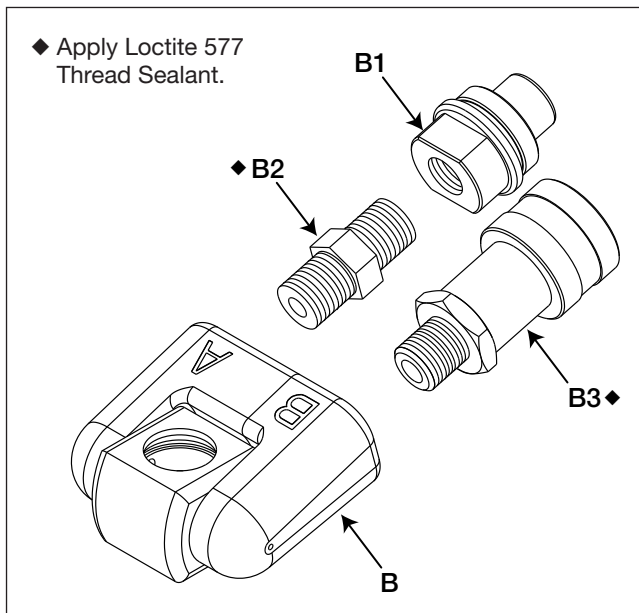

Figure 4, Hydraulic Coupling Replacement

Install new hydraulic fittings by hand. Then, use a wrench to tighten them. Follow steps 6 through 9.

5. Coat the threads on both ends of the adaptor (B2) with Loctite 577 thread sealant. Thread the male coupling (B1) onto one end of the adaptor (B2). Thread the other end of the adaptor (B2) into the *advance* port (marked “A”) of the swivel (B).
6. Tighten the coupling (B1) and adapter (B2) by hand, until they are each finger tight. Then, wrench tighten the fittings an additional 2 to 3 turns beyond finger tight.
7. Coat the threads on the swivel end of the female coupling (B3) with Loctite 577 thread sealant. Thread the coupling into the *retract* port (marked “B”) of the swivel (B).
8. Tighten the coupling (B3) by hand, until it is installed finger-tight. Then, wrench tighten the coupling an additional 2 to 3 turns beyond finger tight.
9. Allow sealant sufficient time to cure (refer to **NOTICE** statement after this step).

NOTICE To allow the sealant sufficient time to cure, wait a minimum period of 3 hours at 68 to 104°F [20 to 40°C], or 6 hours at 40 to 68°F [5 to 20°C] before pressurizing the wrench.

10. Coat O-rings (E and C) with a small amount of silicone grease. Then, carefully slide the swivel assembly (B) onto the swivel post (F).
11. Reinstall the circlip retainer ring (A).
12. Connect hydraulic hoses and cycle the wrench (or drive unit) at 1,000 psi [69 bar] to check for oil leaks. If there are no leaks, cycle the wrench (or drive unit) at 10,000 psi [690 bar] and check again for leaks.

WARNING Pressurized hydraulic oil can penetrate the skin and could cause serious personal injury. Always repair any oil leaks before using the wrench.

7.0 REBUILDING THE SWIVEL ASSEMBLY

Rebuild the swivel assembly as described in the following steps. Refer to Figures 1 and 5.

1. Remove the swivel assembly from the swivel post and remove the hydraulic fittings from the swivel. Refer to steps 1 through 4 in Section 6.0.
2. Loosen and remove socket head capscrew (B9).
3. Firmly rotate swivel arm “A” (B4) and swivel arm “B” (B5) in opposite directions until they become disengaged from each other.
4. Firmly pull swivel arm “A” (B4) and swivel arm “B” (B5) off of the posts of the swivel manifold block.
5. Remove and discard O-rings (B6 and B7).

NOTICE Inspect all components before reassembly. Always replace any worn or damaged parts with new parts. Remove any dirt, old grease or old sealant from reusable parts and make sure that they are clean.

6. Install a new O-ring (B7) into the groove on each swivel arm. Apply silicone grease to O-rings as installed.
7. Install new O-rings (B6) into the grooves on the posts of the swivel manifold block (B8). Apply silicone grease to O-rings as installed.
8. Reinstall swivel arm “A” (B4) and swivel arm “B” (B5) on the posts of the swivel manifold block (B8).
9. Rotate the swivel arms (B4 and B5) toward each other until the tabs are fully engaged in the notches.
10. Coat the threads of the socket head capscrew (B9) with Loctite 243 thread sealant. Tighten the capscrew securely. To allow the sealant sufficient time to cure, wait a minimum period of 3 hours at 68 to 104°F [20 to 40°C], or 6 hours at 40 to 68°F [5 to 20°C] before pressurizing the wrench.

WARNING Capscrew (B9) must remain tightly installed. Never operate wrench with capscrew (B9) loosened or missing. Serious personal injury and/or damage to wrench components may result if swivel arms become loose and/or separated while the wrench is under pressure.

11. Reinstall hydraulic fittings and reinstall the swivel assembly on the swivel post. Test for proper operation. Refer to steps 5 through 12 of Section 6.0 for instructions.

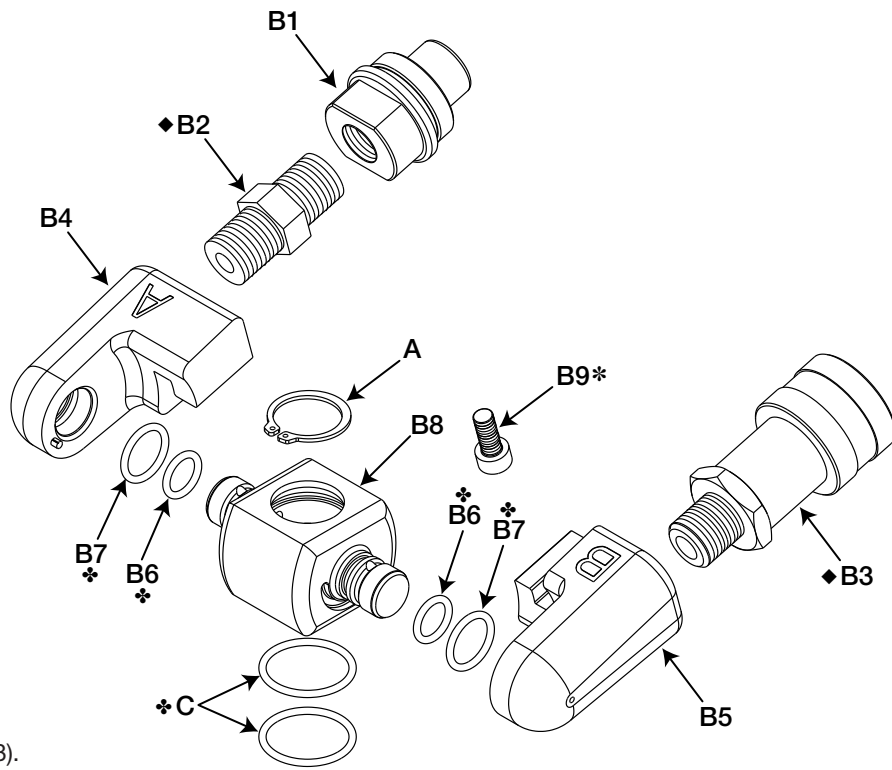

- ❖ Apply silicone grease.
- ◆ Apply Loctite 577 thread sealant (Items B2 and B3).
- * Apply Loctite 243 thread sealant (Item B9).

Figure 5, Exploded Parts View - TSP300 Pro Series Swivel Assembly