

L4184 Rev. C 10/20

Table of Contents:

Section	Page
1.0 IMPORTANT RECEIVING INSTRUCTIONS	1
2.0 SAFETY	1
3.0 PRODUCT DESCRIPTION	4
4.0 PRODUCT DATA	4
5.0 INSTALLATION AND SETUP	6
6.0 OPERATION	8
7.0 INSPECTION, MAINTENANCE & STORAGE	9
8.0 ROUTINE MAINTENANCE PROCEDURES	9
9.0 TROUBLESHOOTING	14



1.0 IMPORTANT RECEIVING INSTRUCTIONS

Visually inspect all components for shipping damage. Shipping damage is not covered by warranty. If shipping damage is found, notify carrier at once. The carrier is responsible for all repair and replacement costs resulting from damage in shipment.

2.0 SAFETY

2.1 Introduction

Read all instructions carefully. Follow all recommended safety precautions to avoid personal injury as well as damage to the product and/or damage to other property. Enerpac cannot be responsible for any damage or injury from unsafe use, lack of maintenance or incorrect operation. Do not remove warning labels, tags, or decals. In the event any questions or concerns arise, contact Enerpac or a local Enerpac distributor for clarification.

If you have never been trained on high-pressure hydraulic safety, consult your distributor or service center for information about an Enerpac Hydraulic Safety Course.

This manual follows a system of safety alert symbols, signal words and safety messages to warn the user of specific hazards. Failure to comply with these warnings could result in death or serious personal injury, as well as damage to the equipment or other property.



The **Safety Alert Symbol** appears throughout this manual. It is used to alert you to potential physical injury hazards. Pay close attention to Safety Alert Symbols and obey all safety messages that follow this symbol to avoid the possibility of death or serious personal injury.

Safety Alert Symbols are used in conjunction with certain Signal Words that call attention to safety messages or property damage messages and designate a degree or level of hazard seriousness. The Signal Words used in this manual are WARNING, CAUTION and NOTICE.



WARNING Indicates a hazardous situation that, if not avoided, **could** result in death or serious personal injury.



CAUTION Indicates a hazardous situation that, if not avoided, **could** result in minor or moderate personal injury.



NOTICE Indicates information considered important, but not hazard related (e.g. messages relating to property damage). Please note that the Safety Alert Symbol will **not** be used with this signal word.

2.2 Hydraulic Pump Safety Precautions (DuroTech Series)



Failure to observe and comply with the following precautions could result in death or serious personal injury. Property damage could also occur.

- Read and completely understand the safety precautions and instructions in this manual before operating the pump or preparing it for use. Always follow all safety precautions and instructions, including those that are contained within the procedures of this manual.
- Operating procedures will vary, depending on the system arrangement and the specific components being used. Always read, follow and completely understand all manufacturer's instructions when operating cylinders, valves and any other hydraulic devices used with the pump. Follow all safety precautions contained in the manufacturer's manuals.
- Always wear appropriate personal protective equipment (P.P.E.) when operating hydraulic equipment. Be sure to wear eye protection, work gloves and protective clothing. Use of additional P.P.E. safety items such as dust mask, non-skid safety shoes, hard hat, and hearing protection (used as appropriate for the conditions) will reduce the chance of personal injuries. The use of these items may also be required by local regulations or laws.

- Do not handle pressurized hoses. Escaping oil under pressure can penetrate the skin. If oil is injected under the skin, see a doctor immediately.
- Do not pressurize disconnected couplers.
- Only use hydraulic cylinders in a coupled system. Never use a cylinder with uncoupled couplers. If the cylinder becomes extremely overloaded, components can fail catastrophically, causing severe personal injury.
- The pump is equipped with a hydraulic safety relief valve that is factory preset to the pump's maximum operating pressure. DO NOT attempt to adjust, bypass or alter the safety relief valve. This valve is not user-adjustable. Adjustment should be performed only by an Enerpac Authorized Service Center.
- The system operating pressure must not exceed the pressure rating of the lowest rated component in the system. Refer to Section 4.1 of this manual for the maximum rated working pressure for your pump model.
- Install pressure gauge(s) in the system to monitor operating pressure. It is your window to see what is happening in the system.
- Never set the pump hydraulic pressure to a higher setting than the maximum rating of the hoses and connected devices. The pressure setting should not exceed the setting of the lowest rated component (pump, cylinder or other hydraulic component) in the circuit.
- Do not exceed equipment ratings. Overloading may cause equipment failure and possible personal injury.
- Always perform a visual inspection of the pump before placing it into operation. If any problems are found, do not use the pump. Have the pump repaired and tested before it is returned to service.
- Fill the pump reservoir with hydraulic oil only to the recommended level. Fill only when cylinders (or other hydraulic actuators) are in their normal de-energized position.
- Never use the pump if it is leaking oil. Do not use the pump if it is damaged, has been altered or is in need of repair.
- Always lift the pump using only the provided lifting handles.
- Allow only trained and experienced personnel to operate the pump.
- Be certain that hydraulic pressure is fully relieved from the cylinder (or other hydraulic actuator) before disconnecting hydraulic hoses, loosening hydraulic fittings, or performing any disassembly or repair procedures.
- If hydraulic equipment is damaged, do not touch or go near any area where high-pressure oil is spraying. Promptly stop usage of the hydraulic equipment and replace the damaged parts with new ones before using the equipment again.
- Do not put your hands or body in line with the face of a disconnected coupler. If the coupler becomes pressurized and leakage occurs, the high-pressure oil stream could penetrate the skin.
- Skin penetration from high-pressure hydraulic oil can result in death or serious personal injury. If oil is injected under the skin, see a doctor immediately.
- Do not drop heavy objects on hoses. A sharp impact may cause internal damage to hose wire strands. Applying pressure to a damaged hose may cause it to rupture.
- Do not lift hydraulic equipment by the hoses or couplers.
- Make sure that all system components are protected from external sources of damage, such as moving machine parts, sharp edges and corrosive chemicals.
- Keep hydraulic equipment away from flames. Flames near a hydraulic oil leak could cause the hydraulic oil to ignite, resulting in a fire.
- For optimum performance, do not expose hydraulic equipment to temperatures of 150°F [65°C] or higher. Excessive heat will soften packings and seals, resulting in possible hydraulic fluid leaks.
- Protect all hydraulic equipment from weld spatter.
- Protect the pump against rain, mud, dust, and humidity when using it outdoors.
- Disconnect air supply hose when pump is not in use for a prolonged period of time. NEVER remove a swivel air connector while the air hose is pressurized.
- Immediately replace worn or damaged parts with genuine Enerpac parts. Enerpac parts are designed to fit properly and to withstand high loads. Non-Enerpac parts may break or cause the product to malfunction.

NOTICE

- Hydraulic equipment must only be serviced by a qualified hydraulic technician. For repair service, contact the Enerpac Authorized Service Center in your area.
- To help ensure proper operation and best performance, use only genuine Enerpac hydraulic oil.

2.3 General Workholding Safety Precautions

⚠ WARNING

Failure to observe and comply with the following precautions and instructions could result in death or serious personal injury. Property damage could also occur.

- Although hydraulic operation moves the control of the clamping fixture to an area of greater safety, operators must still remain alert and use common sense practises during their work.
- Use care when selecting components for the workholding application so that safe operation is ensured. Be certain that all components and devices are of adequate rated capacity to perform their intended functions.
- Verify that all appropriate safety measures have been taken to avoid the risk of injury and property damage from your application or system.
- Be sure that all personnel involved with operating or servicing the workholding devices read and understand the information contained in the manuals included with these devices. Observe and follow all safety instructions and precautions contained in the manuals.
- Design the control units of power operated clamping systems to avoid inadvertent or unauthorized activation.
- Be sure that clamping cylinders and other similar workholding devices are properly positioned before clamping forces are applied.
- Maintain a safe distance from clamping elements and workpiece to avoid personal injury. Stay clear of pinch points. Keep your hands, feet and body away from the clamping area.
- Use mechanical devices and not fingers to hold a part in place until the clamping hydraulics are activated.

⚠ CAUTION

Failure to observe and comply with the following precautions could result in minor or moderate personal injury. Property damage could also occur.

- Be careful to avoid damaging hydraulic hoses. Avoid sharp bends and kinks when routing hydraulic hoses. Do not exceed the minimum bend radius specified by the hose manufacturer. Using a bent or kinked hose will cause severe back-pressure. Sharp bends and kinks will internally damage the hose, leading to premature hose failure.

- To avoid unexpected operation of clamping devices, be sure that control valves are in the neutral position before starting the pump.
- Be certain that clamping devices are activated before the main spindle is started.
- Do not apply an off-center load to the part being machined. Clamping force must be applied directly over the support point.
- Use check valves to maintain hydraulic pressure to clamping devices in the event of a hydraulic line failure.
- Contact your Enerpac office or representative for guidance if in doubt regarding the proper safety precautions to be taken when designing and setting-up your system.

2.4 Additional Safety References

Consult the applicable industry and/or government standards in your country or region for additional safety precautions and work rules applicable to hydraulic pumps, hydraulic workholding devices and related components.

3.0 PRODUCT DESCRIPTION

The Enerpac DuroTech Series Air Driven Hydraulic Pump is intended for high-use, high-flow industrial workholding applications.

Three different maximum pressure ratings are available to suit a wide variety of user requirements. In addition, a choice of two different valve manifold styles is available to accommodate D03 or CETOP type valves.* Refer to Table 4.1 for details.

Each valve manifold contains four stations, allowing for up to four control valves to be installed. Control valves are available from Enerpac (sold separately).

The dual action pump element combines smooth operation with maximum durability. A built in air filter/regulator allows easy adjustment of pump hydraulic pressure and helps protect the pump air components from contaminants.

The large 1.8 gallon [6.8 liter] hydraulic reservoir provides ample oil capacity to power multiple hydraulic devices.

A removable metal shroud allows easy access to the pump element for routine inspection and maintenance activities.

* **Note:** CETOP style manifolds are subject to delayed availability. Contact Enerpac for additional information.

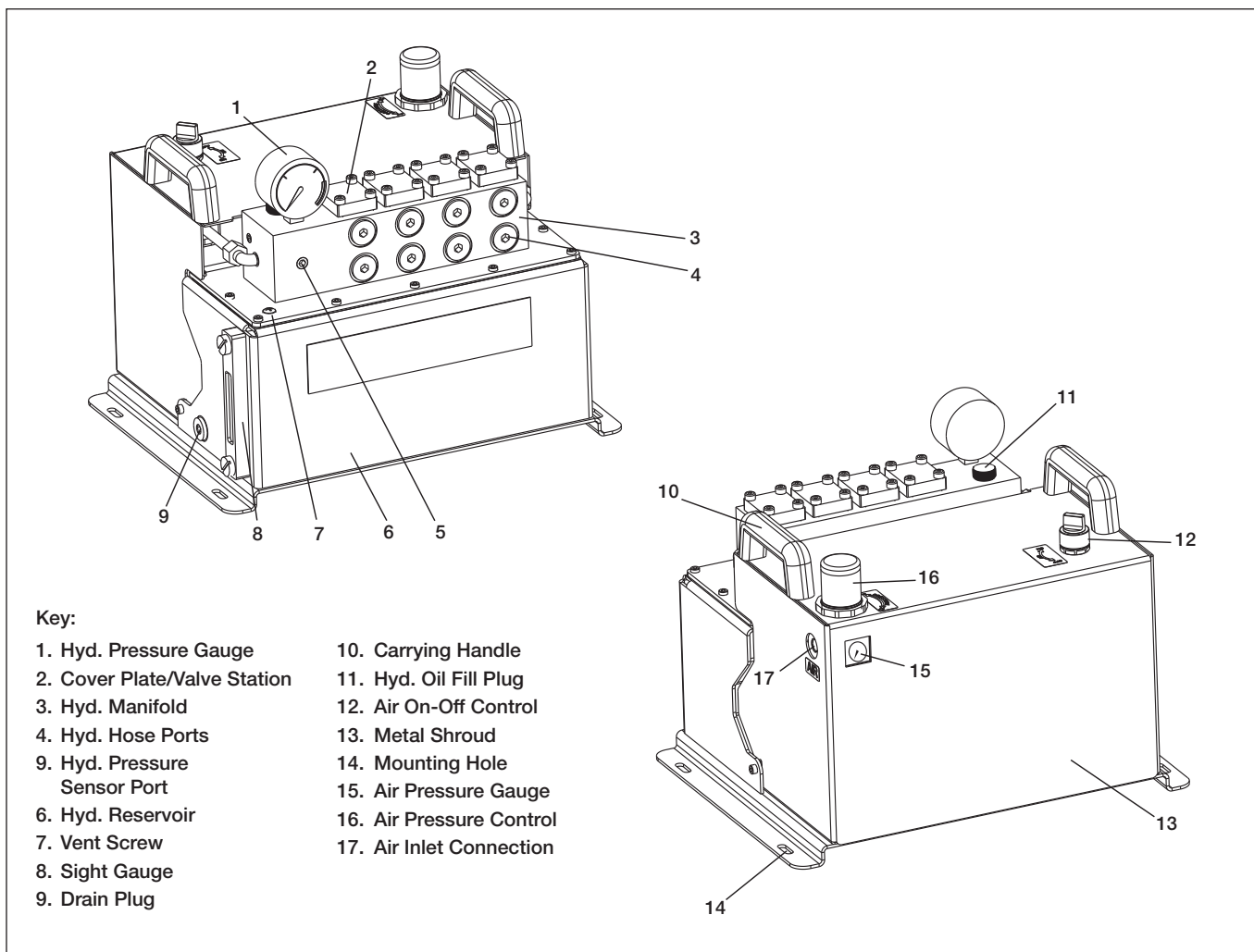

Figure 1 - Major Features and Components

4.0 PRODUCT DATA

4.1 Specifications, Pressure, Flow and Air Consumption

Pump Series	Hydraulic Pressure						Pressure Ratio Hydraulic to Air	Max. Hydraulic Flow @100 psi Air ²⁾ [6.9 bar]		Air Pressure Range		Max Air Consumption @ 100 psi Air [6.9 bar]	
	Max. Hyd. Working Pressure ¹⁾		Max. Hyd. Pressure @100 psi Air ²⁾ [6.9 bar]		Hyd. Safety Relief Valve Setting								
	psi	bar	psi	bar	psi	bar	-	in ³ /min	l/min	psi	bar	scfm	m ³ /min
WAP07	1920	132	1595	110	2000	138	16:1	612	10.0	30-120	2.0-8.2	24	0.68
WAP15	2760	190	2320	160	3000	207	23:1	465	7.6	30-120	2.0-8.2	24	0.68
WAP30	5280	364	4785	330	5500	379	48:1	252	4.1	30-110	2.0-7.6	20	0.57

1) Based on 120 psi [8.3 bar] air pressure for the WAP07 and WAP15 Series, and 110 psi [7.6 bar] air pressure for the WAP30 Series.

2) At zero (0) psi/bar hydraulic pressure.

4.2 Additional Specifications

Pump Series	Reservoir Usable Oil Capacity			Hydraulic Oil Type	Approximate Weight (not including hydraulic oil or control valves)		Operating Temperature Range		Sound Level dBA
	Gallons	in ³	Liters		lb	kg	°C	°F	
WAP07 WAP15 WAP30	1.8	415	6.8	Enerpac HF (Refer to Section 5.3)	71	32.2	0 to 60	32 to 150	75

Pump Series	Air inlet connection	Hydraulic Hose Connections		Hydraulic Valve Manifold Stations		Number of Stations
		Model No. ending in D	Model No. ending in C	Model No. ending in D	Model No. ending in C	
WAP07 WAP15 WAP30	1/4" NPT	#8 SAE	G3/8"	D03	CETOP	4

4.3 Schematic Diagram

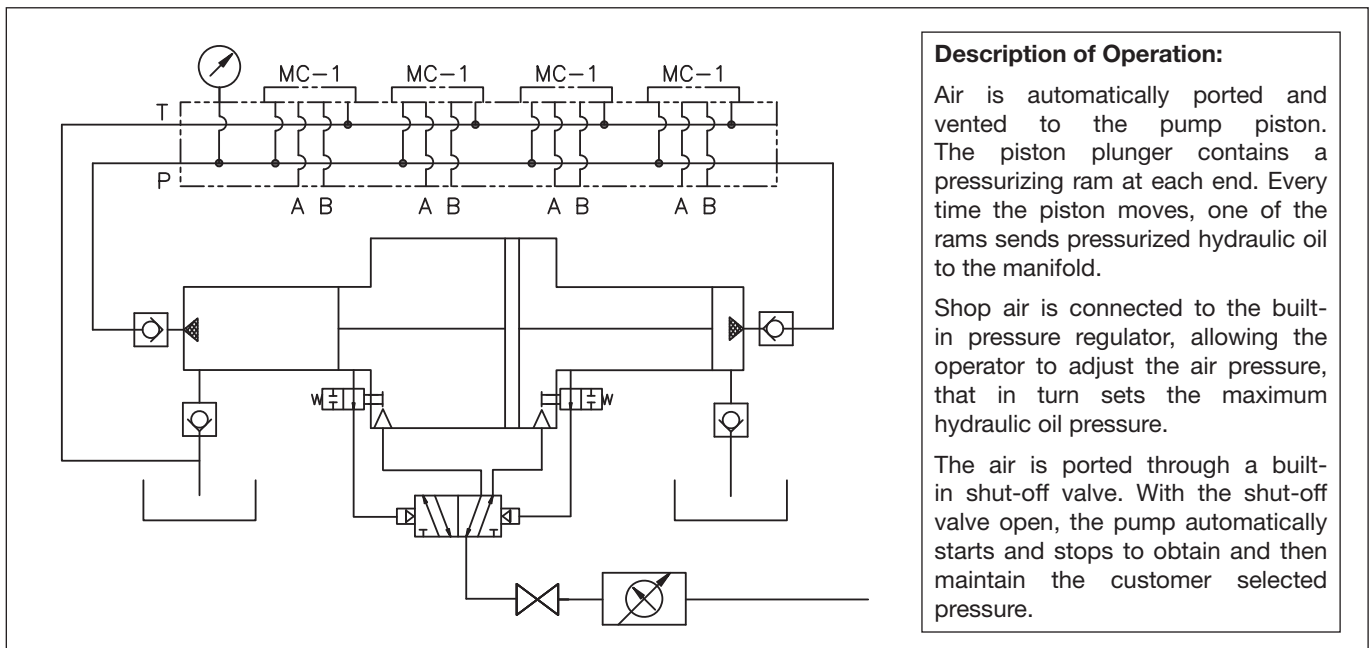

4.4 Pump Dimensions

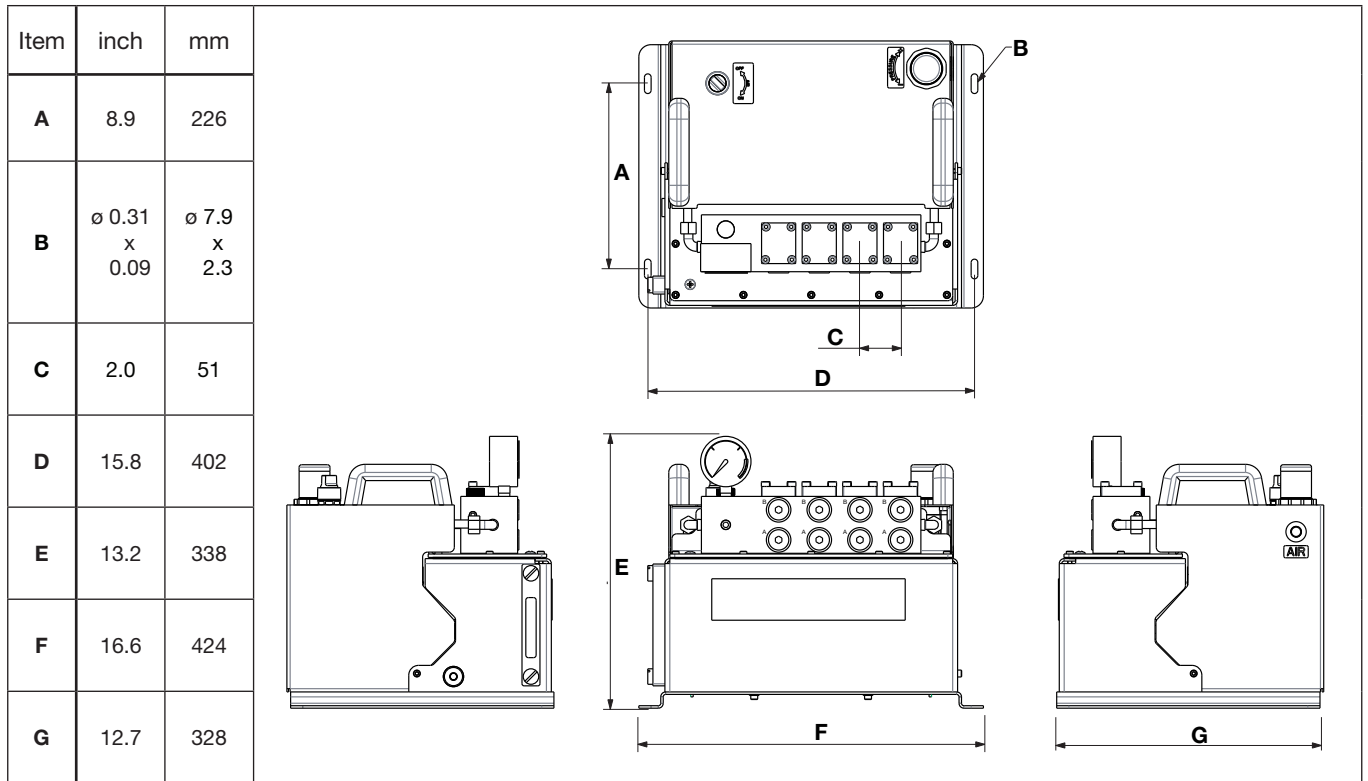

4.5 Performance Curves (hydraulic pressure vs. flow)

Imperial

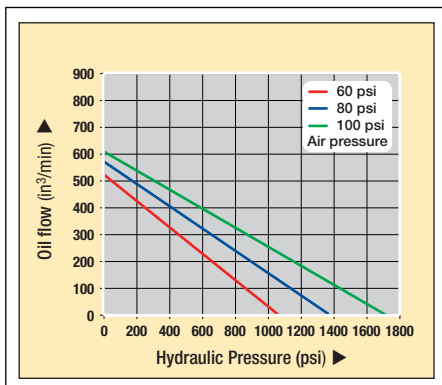

WAP07 Series

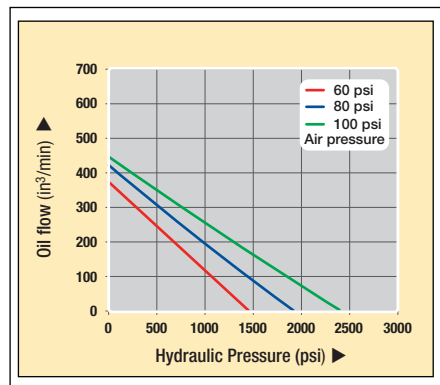

WAP15 Series

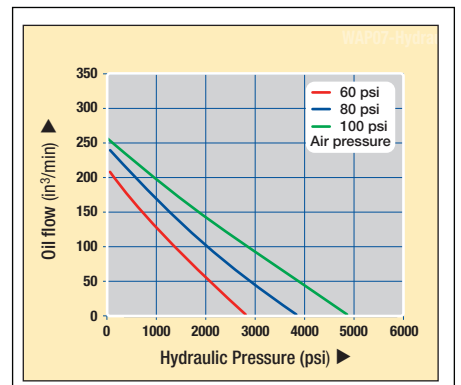

WAP30 Series

Metric

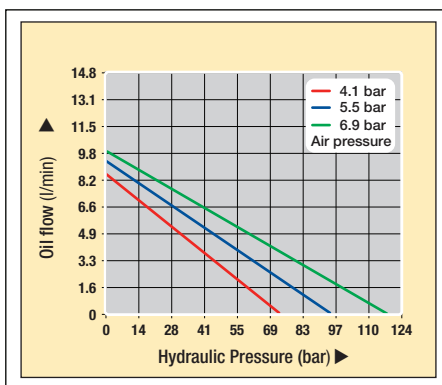

WAP07 Series

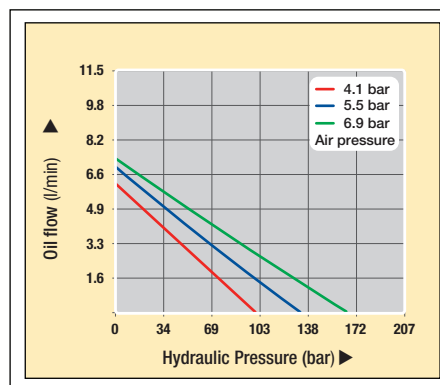

WAP15 Series

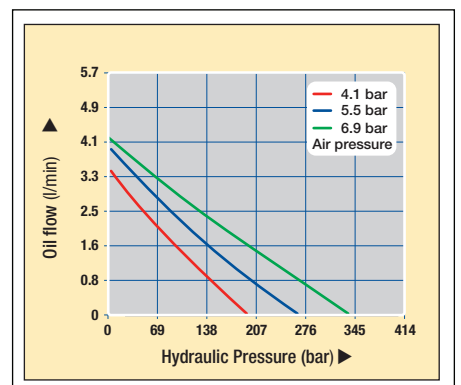

WAP30 Series

NOTICE Performance will be significantly diminished if air pressure falls below 50 psi [3.4 bar]. Actual performance may vary from values shown, due to seal friction, internal pressure drops and manufacturing tolerances.

5.0 INSTALLATION AND SETUP

5.1 Mounting

Install the pump on a solid and level horizontal surface that is capable of supporting the weight of the pump, control valves and any associated equipment.

Four slotted mounting holes are provided on the pump bottom flange. See Figure 2. Secure the pump with 5/16" SAE or M8 ISO screws (user supplied).

NOTICE Pump must be operated only in the horizontal position (with the pump bottom flange facing down). To avoid damage to pump and possible oil leakage, do not attempt to mount the pump on a wall or other vertical surface.

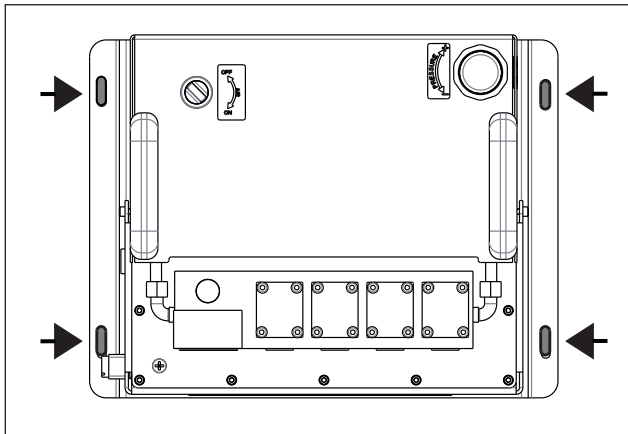

Figure 2 - Mounting Holes

5.2 Valve Installation

The pump is available with a choice of D03, CETOP or VP style control valve ports.

Control valves are sold separately and are not included with the pump. Refer to the Enerpac website or catalog for a description of available control valves and related accessories. Consult your Enerpac distributor or authorized service center if additional valve selection guidance is needed.

NOTICE Tandem center control valves should not be used with DuroTech Series pumps.

When installing control valves, always work in a clean and dry area. Take all appropriate precautions to avoid contamination and dirt entry. Follow the valve manufacturer's instructions carefully to ensure proper installation. Be sure that the cover plates remain tightly installed over all unused valve stations. See Figure 3.

The Enerpac MC-2 cross over cover plate (optional accessory) can be used to covert A and B outlet ports to P and T ports for use with remote mounted valves.

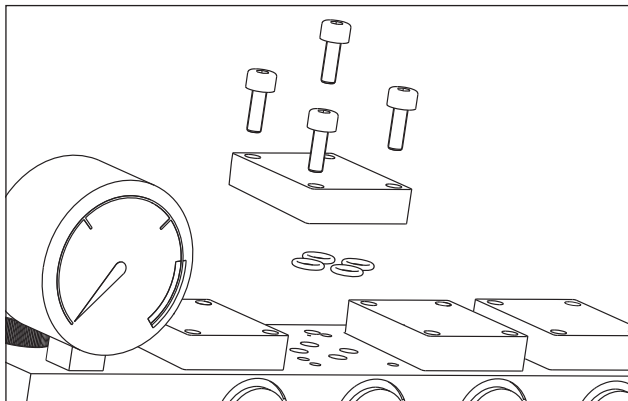

Figure 3 - Control Valve Mounting Station and Cover Plate (D03 Manifold Shown)

5.3 Hydraulic Reservoir

The pump is shipped without oil. Reservoir must be filled with oil before pump is operated.

Use of Enerpac HF Series ISO 32 hydraulic oil is strongly recommended. Enerpac HF oil is available at your local Enerpac Distributor or Authorized Service Center.

NOTICE

- Failure to use the correct oil type (high-quality ISO 32 hydraulic oil) may result in damage to pump hydraulic components and will void the product warranty.
- Be sure that the oil is clean. The oil cleanliness should be maintained to a maximum level of 18/16/13 per the ISO 4406 standard. If the oil develops a milky, cloudy or dark appearance, it should be changed immediately.
- To avoid overfilling and possible equipment damage, add oil to the pump reservoir only after all connected hydraulic devices are de-energized and system pressure is completely relieved.

Add oil as described in the following steps:

1. Be certain that the air shut-off valve is in the OFF position
2. Verify that the pump hydraulic pressure gauge and pump air pressure gauge both read zero (0) psi/bar.
3. Be sure that all connected hydraulic devices are fully de-pressurized.
4. Loosen the vent screw one full turn to provide reservoir venting.
5. Loosen and remove the oil fill plug. See Figure 4.
6. Slowly pour oil through the oil fill port while watching the level in the reservoir sight gauge. Stop pouring when the reservoir is 1/2 to 3/4 full. DO NOT OVERFILL. Refer to Section 5.4 for additional information.
7. Reinstall the oil fill plug after adding oil. Tighten oil fill plug snug tight.

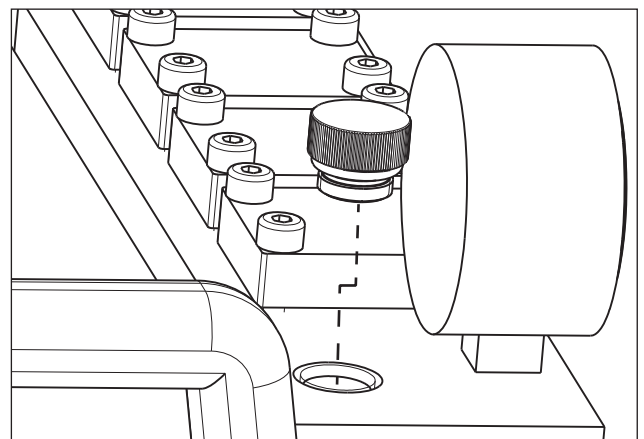

Figure 4 - Oil Fill Plug

5.4 Oil Level

The oil level sight gauge is located on the left-hand side of the pump,

The reservoir should be 1/2 to 3/4 full with all cylinders or other hydraulic actuators fully retracted. See Figure 5.

Never allow the oil level to rise above the top (high) line or fall below the bottom (low) line.

NOTICE Always check oil level with the air on-off control in the OFF position and the hydraulic system fully depressurized. Be certain that all hydraulic actuators are fully retracted. Failure to observe this instruction may result in the reservoir becoming overfilled.

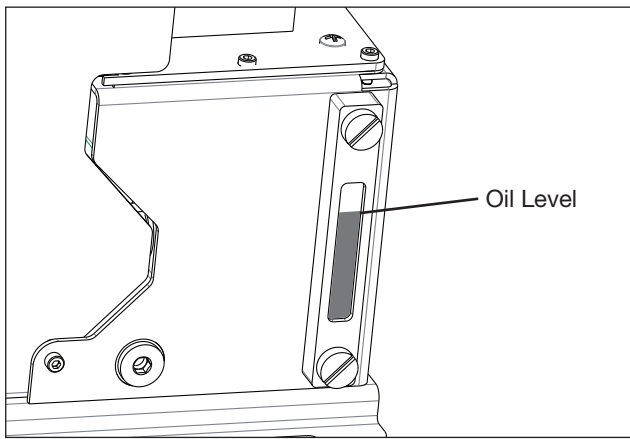

Figure 5 - Oil Level Sight Gauge

Add oil if the oil level drops below 1/2 full. A small amount of additional oil may need to be added to the reservoir after the pump has been operated for the first time.

5.5 Hydraulic Hose Connections

The advance and retract ports are located on the front of the hydraulic manifold. See Figure 6. Note that the top ports are labeled “B” and the bottom ports are labeled “A”.

Port type and thread size will vary, depending on pump model. Refer to Section 4.2 of this manual for additional information.

All hoses, fittings and other hydraulic components in the circuit must be rated at or above the pump maximum working pressure. Refer to sections 4.1 and 6.2 of this manual for additional maximum pressure information.

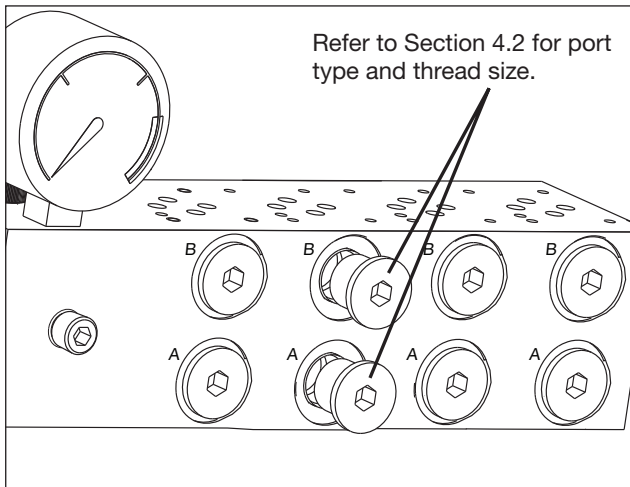

Figure 6 - Hydraulic Connections

5.6 Air Requirements

CAUTION Before connecting the air supply hose, ensure that the air on-off control is in the OFF position. Failure to follow these directions may result in unintended pump startup when air supply hose is connected.

To ensure optimum performance, the air source must be capable of providing a constant supply of air at the required pressure and flow rate for your pump model. Refer to Table 4.1 for additional information.

NOTICE Supply air pressure should not exceed 110 psi [7.5 bar] static for WAP30 Series models. Supply air pressure should not exceed 120 psi [8.2 bar] static for WAP07 and WAP15 Series models.

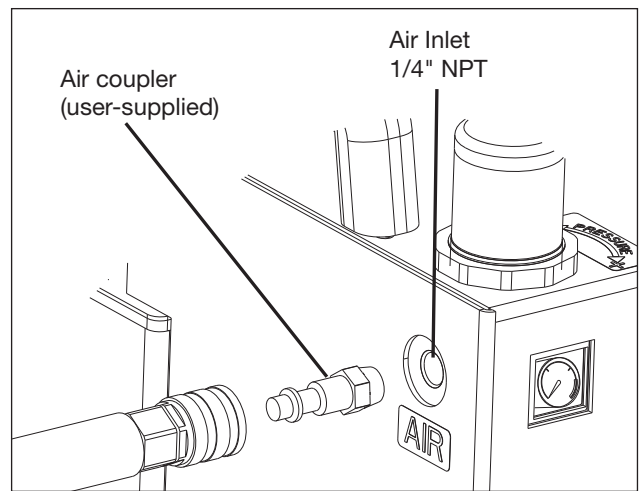

Figure 7 - Pump Air Inlet

Use only dry and filtered compressed air. Use of a water separator is strongly recommended. Pump internal components are self-lubricating. Lubricated air is permitted but NOT required.

The pump air inlet connection is a 1/4" NPT fitting. See Figure 7.

A suitable male air coupler (user supplied) must be installed between the pump air inlet connection and the air supply line or hose. Use PTFE sealing tape (or other suitable pipe sealant) on the threads and torque to 7.4-11.0 ft-lb [10-15 Nm].

To ensure sufficient air flow, the inside diameter of the air supply hose or line must be not less than 0.39 inch [10 mm].

5.7 Venting

A vent screw is located on the pump reservoir. Before using the pump, loosen the vent screw one full turn to open the vent. See Figure 8.

NOTICE Reservoir must be vented during pump operation. Failure to open the vent may result in cavitation and damage to pump components.

The vent should also be opened before adding oil to the reservoir. This will allow the oil to flow more easily into the tank.

The vent should be fully closed during sustained periods of inactivity or whenever the pump is stored. When closing the vent, tighten the vent screw snug tight, so that the underside of the screw head only slightly compresses the O-ring seat.

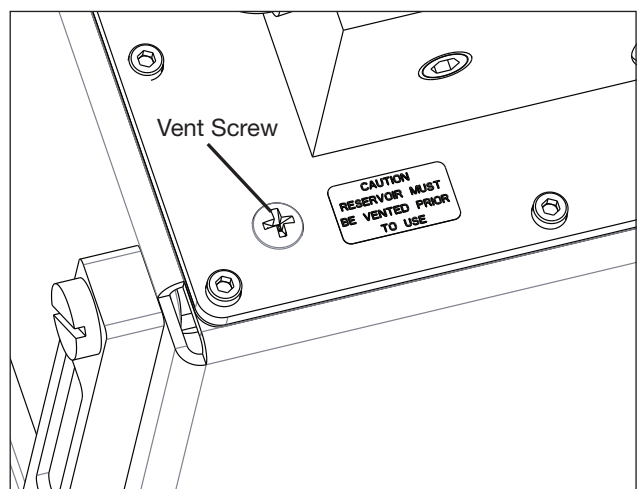

Figure 8 - Vent Screw

5.8 Air On-Off Control

The pump air on-off control operates as follows:

ON position:

- Air from the plant air supply is directed to the pump pneumatic circuit, activating the pump element. Hydraulic pressure will start building immediately, and will be indicated on the pump hydraulic pressure gauge.
- Pump will stop automatically when the user-adjustable pressure setting is reached. Refer to Section 6.1 for additional details.

NOTICE The user-adjustable pressure setting must be adjusted before the pump is placed into operation. Refer to directions in Section 5.9.

OFF position:

- Air from the plant air supply to the pump pneumatic circuit is blocked (shut-off).
- Some residual air pressure may still be present in the pump pneumatic circuit.

WARNING

Air downstream of the air on-off control is NOT vented when the OFF position is selected. Residual air pressure may be present downstream of the control. Movement of hydraulic actuators could occur when control valves are shifted, even when the air on-off control is in the OFF position.

To prevent possible injury, stay clear of hydraulic actuators until all pressure is completely relieved. With the air on-off control in the OFF position, shift the control valve(s) through all positions several times to relieve any residual pressure.

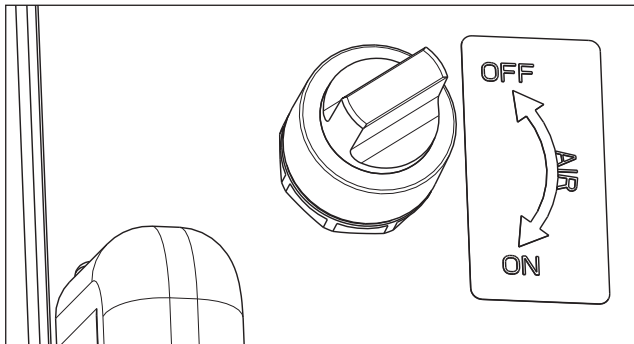

Figure 9 - Air On-Off Control

5.9 Air Pressure Adjustment

Adjustment of the pump air pressure setting results in a corresponding change to the pump hydraulic pressure setting. Adjust the pressure setting as described in the following steps:

1. Move the air on-off control to the OFF position.
2. Connect the air supply hose to the pump air inlet connection.
3. Pull up the air pressure adjustment knob. See Figure 10.
4. Turn the air pressure adjustment knob slowly counterclockwise until the pump air pressure gauge indicates about 43.5 psi [3 bar].
5. While watching the pump air pressure gauge, slowly rotate the air pressure adjustment knob clockwise until the gauge indicates the air pressure setting that corresponds with the hydraulic pressure setting required for your application.

NOTICE The hydraulic-to-air pressure ratio varies, depending on pump model. Refer to the ratios listed in the table in Section 4.1 and to the pressure-flow graphs in Section 4.5.

6. To prevent unexpected actuator operation from occurring in the next step, be sure that all control valves are in the neutral position.

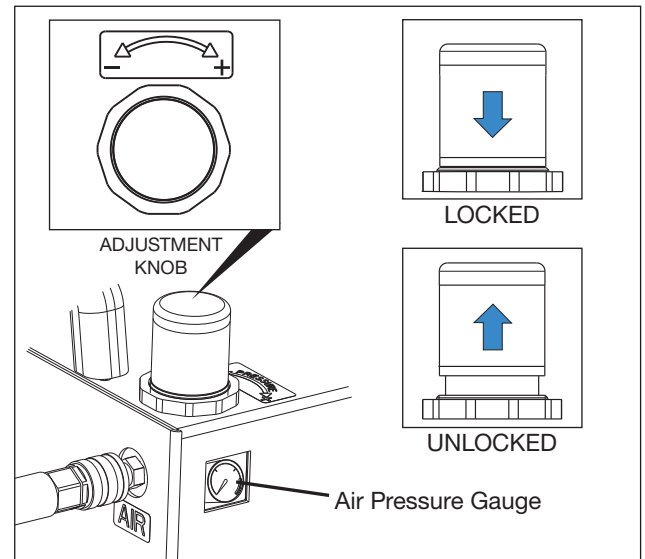

Figure 10 - Air Pressure Adjustment Knob and Pressure Gauge

7. Move the pump air on-off control to the ON position.
8. Check the pump hydraulic pressure gauge. If necessary, readjust the air pressure up or down as required, until the corresponding hydraulic pressure setting is correct for your application.

WARNING The pressure reading shown on the pump hydraulic pressure gauge must not exceed the maximum rating of the lowest rated hydraulic component in the circuit. Failure to observe this instruction may result in catastrophic failure, high pressure oil leakage and/or skin penetration. Serious personal injury or death could result.

9. After confirming the proper setting, press down on the air adjustment knob to lock the setting.

5.10 Air Removal

Trapped air must be removed from the hydraulic cylinder(s) and hoses before the pump is placed into operation.

1. Move the air on-off control to the ON position.
2. Under no load, repeatedly cycle the cylinders (or other hydraulic actuators) from the fully extended to fully retracted position until operation is smooth. Repeat this procedure for each valve station.

Smooth operation indicates that air has successfully been removed from the system.

3. Move the air on-off control to the OFF position.
4. Check the oil level in the pump hydraulic reservoir. If oil level has dropped, add additional oil to the reservoir as required.

NOTICE Refer to Section 5.3 of this manual for hydraulic oil requirements and reservoir filling instructions.

5. Check the air pressure setting after performing air removal procedures. The air pressure setting (and the corresponding hydraulic pressure setting) may drop slightly after the pump has been operated for the first time. If readjustment is required, refer to the instructions in Section 5.9.

6.0 OPERATION

Specific pump operation procedures will vary, depending on control valve type and configuration, workholding devices used and other factors. For detailed operating instructions and related information, refer to the instruction sheet included with your hydraulic valve(s), cylinder(s) or other actuator(s). Refer to Section 6.1 for a general overview of pump operation. Also follow the additional instructions and precautions contained in sections 6.2 and 6.3 of this manual.

6.1 Overview of Operation

Typical operation - with standard closed center or float center control valves (pressure holding type):

- The pump will start immediately if the air on-off control is moved to the ON position while the control valve is in the neutral position. The pump will stop automatically (and remain idle) when pressure reaches the user-adjustable pressure setting.
- If the pump is idle, and the control valve is moved from the neutral position to either the advance or retract position, the pump will start immediately. The pump will stop automatically when pressure reaches the user-adjustable pressure setting.

Typical operation - with spool type closed center or float center control valves (non-sealed type):

- When the air on-off control is in the ON position and the control valve is in the neutral position: The pump will start and stop as needed to maintain the user-adjusted pressure. This feature helps compensate for the normal internal oil leakage present in a spool type control valve.
- Operation is otherwise the same as described for the standard (pressure holding type) control valves.

NOTICE It is mandatory that the operator has a full understanding of all instructions, safety precautions and applicable safety regulations before operating any high force hydraulic equipment. If any questions or concerns, contact your local Enerpac Distributor or Authorized Service Center.

6.2 Maximum Hydraulic Working Pressure

Rated maximum hydraulic working pressure varies, depending on the pump model:

- WAP07 Series: 1920 psi [132 bar].
- WAP15 Series: 2760 psi [190 bar].
- WAP30 Series: 5280 psi [364 bar].

WARNING

Maximum hydraulic system pressure is limited by an internal safety relief valve that is set slightly higher than the pump's maximum rated hydraulic working pressure. Do not attempt to adjust, bypass or alter this valve. It is factory set and is not user-adjustable.

Be certain that all hydraulic hoses, hydraulic cylinders and any other connected hydraulic devices are rated at or above the maximum hydraulic working pressure for your pump model.

Serious personal injury or death could occur if these instructions and precautions are not followed.

6.3 Relieving Pneumatic and Hydraulic Pressure

WARNING

Failure to observe the following instructions and precautions could result in dangerous high pressure oil leakage and possible skin penetration. Death or serious personal injury could result.

Perform the following procedure before disconnecting any hydraulic hoses or lines from either the pump manifold or a connected device, before loosening any hydraulic fittings or before servicing the pump or any connected devices:

1. Move the pump air on-off control to the OFF position. See Figure 9.
2. Disconnect the air supply hose from the pump air inlet connection. Be certain that the pump air pressure gauge indicates zero (0) psi/bar. See Figure 10.
3. Cycle the hydraulic control valve(s) to relieve residual pressure in the pump hydraulic system (this will also remove residual pressure in the pump pneumatic system).

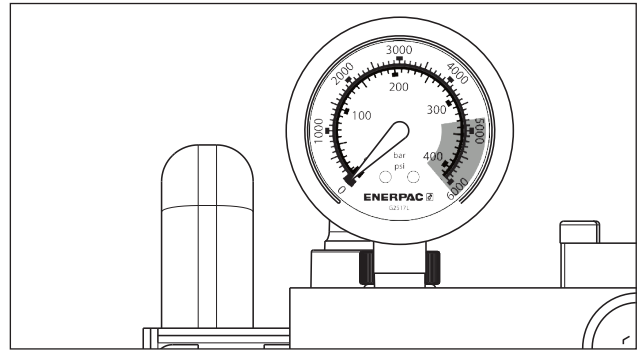

Figure 11 - Pump Hydraulic Pressure Gauge

4. Verify that all hydraulic pressure is completely relieved:
 - Check that the pump hydraulic pressure gauge indicates zero (0) psi/bar. See Figure 11.
 - Verify that other hydraulic pressure gauges in the system (if present) also indicate zero (0) psi/bar.
 - Be sure that no hydraulic hoses are stiff, which may indicate trapped pressure.
5. If any hydraulic pressure remains, cycle the control valve(s) again to relieve pressure. Then, re-check the hydraulic pressure gauge(s) to be sure that no pressure is indicated.

7.0 INSPECTION, MAINTENANCE & STORAGE

- Periodically check the pump for loose hydraulic connections leaks and obvious problems. Replace any damaged components immediately.
- Monitor the pump oil temperature during operation. Do not exceed oil temperatures above 150°F [65°C].
- Install dust caps and plugs on all hydraulic couplings after the hydraulic hoses are disconnected from the pump.
- Keep the pump and all hydraulic components clean.
- Change the hydraulic oil at the recommended interval shown in Section 8.2 of this manual. Change the oil immediately if dirty, or if contamination is suspected.
- Store the pump in a clean, dry and secure location. Keep the stored pump and hoses away from heat and direct sunlight.
- If repair parts are required, refer to the Enerpac website (www.enerpac.com) for the repair parts sheet applicable to your pump model.

NOTICE Hydraulic equipment must only be serviced by a qualified hydraulic technician. For repair service, contact the Enerpac Authorized Service Center in your area.

8.0 ROUTINE MAINTENANCE PROCEDURES

8.1 Preparation

Always perform the following steps before beginning any maintenance or repair procedures contained in Section 8:

1. Disconnect the air supply hose and fully relieve pneumatic and hydraulic pressure. Follow the steps in Section 6.3.
2. Disconnect hydraulic hoses from hydraulic manifold. Install plugs in open ports.
3. Position the pump on a workbench or other substantial work surface.

NOTICE Pump dry weight is approximately 71 lb [32.2 Kg]. This figure does NOT include the weight of the hydraulic oil or the control valves. Actual weight will vary, depending on amount of oil in reservoir and number of control valves installed on manifold.

4. Remove the two screws located on either side of the pump shroud. Remove the pump shroud and position it behind the pump on the work surface. Be careful not to damage the flexible air tubing, which must remain connected. See Figure 12.

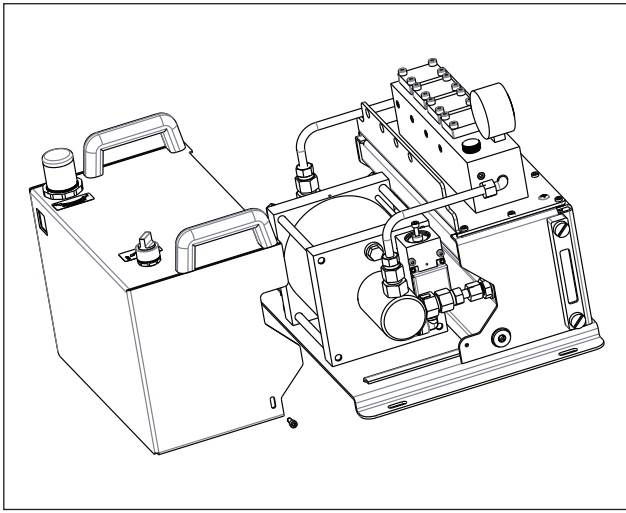

Figure 12 - Pump Shroud Removal
(Note: air tubing removed for illustrative purposes)

8.2 Oil Change

Change the hydraulic oil every 12 months. If the oil is dirty or contaminated, change the oil immediately. Refer to the following steps:

1. Fully relieve pressure in the pneumatic and hydraulic circuits. Disconnect hoses. Refer to maintenance preparation procedures in Section 8.1 of this manual. Also refer to pressure relief procedures in section 6.3.
2. Place the pump on a workbench or other substantial work surface. To allow draining in the next step, position the pump so that the side with the oil drain plug is even with the edge of the workbench.
3. Place a suitable container under the pump oil drain plug. The container capacity must be 1.8 gallon [6.8 liter] or larger.
4. Slowly unscrew the oil drain plug and remove it. See Figure 13. Allow the old oil to flow into the container.

NOTICE Dispose of used oil in accordance with all applicable laws and regulations.

5. Clean and reinstall the oil drain plug.
6. Remove the oil fill plug. See Figure 4.

NOTICE Use of Enerpac HF hydraulic oil is strongly recommended. Refer to Section 5.3 for additional information.

7. Slowly pour new oil through the oil fill opening while watching the oil sight gauge. Continue until reservoir is 1/2 to 3/4 full. **DO NOT OVERFILL.**
8. Reinstall the oil fill plug.

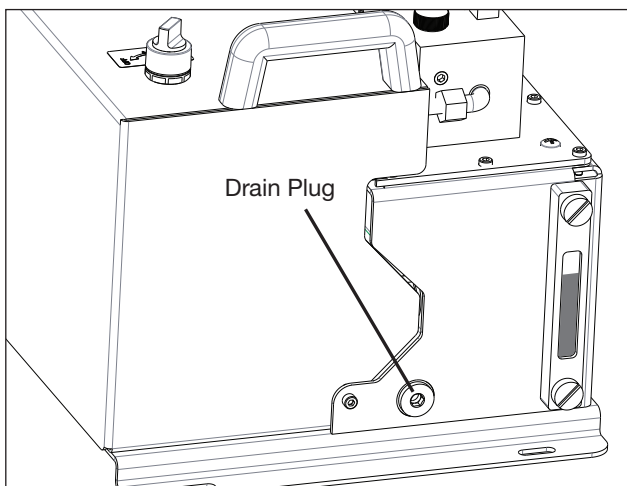

Figure 13 - Drain Plug

9. Reconnect hoses and test pump operation without load before placing the pump back into service. Cycle the hydraulic cylinders (or other hydraulic actuators) until all air is removed and operation is smooth.

8.3 Suction Strainer Replacement

Two suction strainer filters are located inside the pump oil reservoir. Replace these strainers if there is a noticeable drop in oil flow or if it is suspected that the oil is dirty or contaminated. Refer to the following steps:

1. Fully relieve pressure in the pneumatic and hydraulic circuits. Disconnect hoses. Remove pump shroud. Refer to maintenance preparation procedures in Section 8.1 of this manual. Also refer to pressure relief procedures in Section 6.3.
2. Place the pump on a workbench or other substantial work surface.
3. Fully drain all oil from the hydraulic reservoir. Refer to the steps in Section 8.2.

NOTICE To ensure cleanliness, the hydraulic oil **MUST** be changed whenever the suction strainers are replaced.

4. Check that the pump hydraulic pressure gauge indicates zero (0) psi/bar. Hydraulic pressure must be completely relieved before loosening hydraulic fittings in the following step.
5. Loosen the connectors located on each end of the hydraulic manifold. Refer to Figure 14.

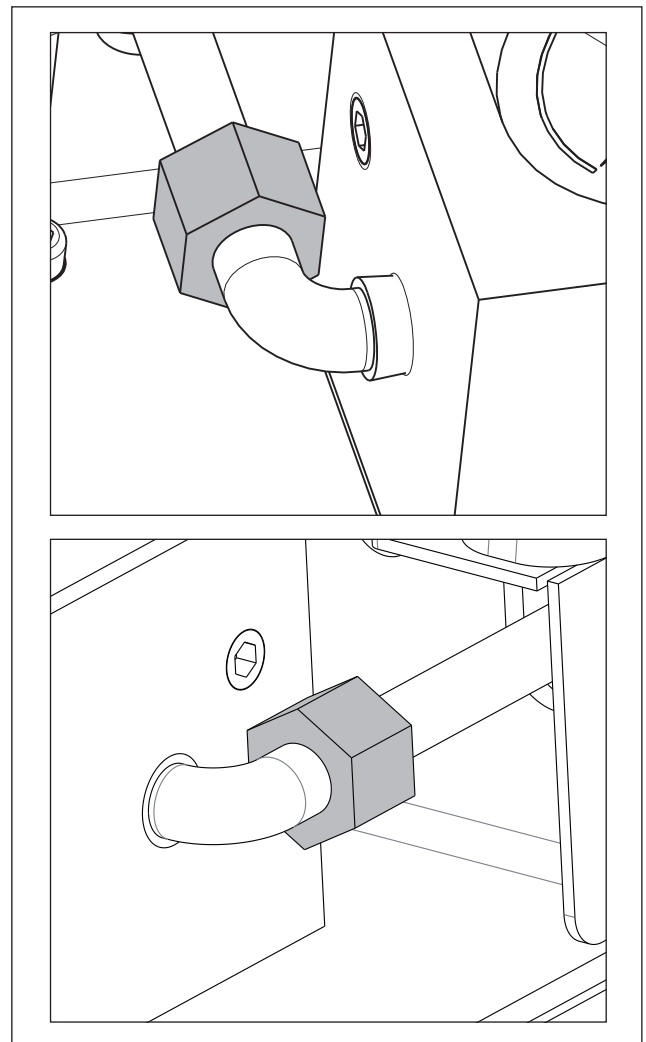

Figure 14 - Connectors
(Located on each end of manifold)

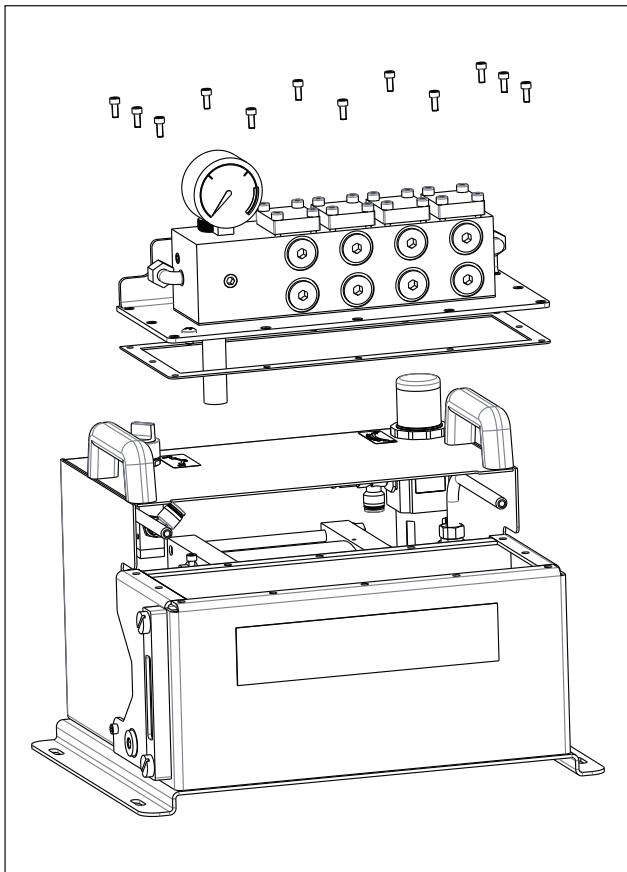

Figure 15 - Manifold Assembly

- Remove the bolts and sealing washers securing the hydraulic manifold and cover plate to the hydraulic reservoir. See Figure 15.

NOTICE Hydraulic manifold and cover plate assembly weighs approximately 20 lb. [9 kg]. Manifold mounted control valves will add additional weight.

- Carefully lift the manifold and cover plate assembly straight up until it is removed from the hydraulic reservoir. See Figure 15. Set this assembly aside, in a clean and dry location.
- Install caps or plugs over all open fittings to prevent dirt entry.
- Inspect the hydraulic reservoir. Remove any sludge or debris from the reservoir interior.
- Unscrew and remove each oil suction strainer. Discard both used suction strainers. See Figure 16.

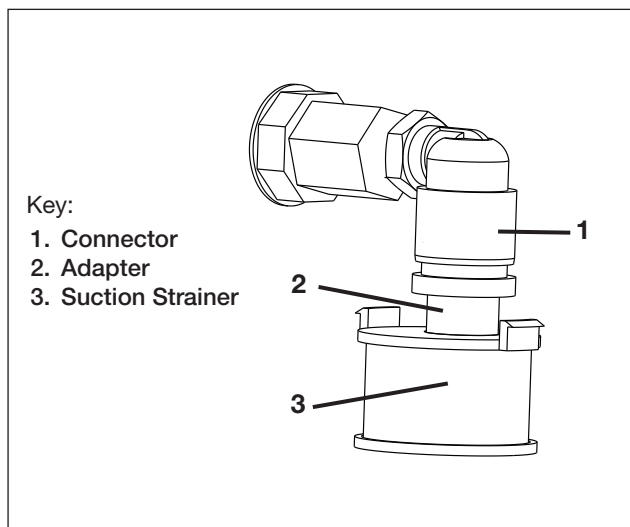

Figure 16 - Suction Strainer

- Install two new oil suction strainers. Be sure that each new suction strainer is oriented as shown in Figure 16. Hydraulic fittings must be assembled so that flat side of suction strainer is parallel with reservoir floor. Refer to the pump repair parts sheet for part number.
- Clean the mating surfaces of the reservoir and the hydraulic manifold cover plate.
- Check the condition of the reservoir gasket. If the gasket is worn or deteriorated, install a new reservoir gasket. Refer to the pump repair parts sheet for part number.
- Remove caps and plugs installed in step 8.
- Carefully lift the manifold and cover plate assembly and position it directly over the hydraulic reservoir opening. Note the locating tabs on either side of the reservoir flange.
- Slowly lower the assembly until the manifold cover plate is supported by the hydraulic reservoir flange. Align bolt holes.
- Apply PTFE pipe thread sealing tape to the threads of the two hydraulic tubes. Engage threads of connectors and hydraulic tubes. Tighten each connector until finger tight. DO NOT final tighten at this time.
- Secure the manifold cover plate to the hydraulic reservoir with twelve bolts and sealing washers. Torque each bolt to 20-22 in-lbs [2.26-2.49 Nm].
- Tighten both connectors an additional 2-3 full turns beyond finger tight.
- Refill the hydraulic reservoir. Refer to the steps in Section 8.2 of this manual.
- Reconnect hoses and test pump operation without load before placing the pump back into service. Cycle the hydraulic cylinders (or other hydraulic actuators) until all air is removed and operation is smooth.

8.4 Air Filter/Regulator

The air filter/regulator contains a removable filter bowl and cleanable air filter. Periodically check the filter bowl for accumulated water and clean the filter. Refer to the following procedure:

- Fully relieve pressure in the pneumatic and hydraulic circuits. Disconnect hoses. Remove pump shroud. Refer to maintenance preparation procedures in Section 8.1 of this manual. Also refer to pressure relief procedures in Section 6.3.
- Locate the air filter/regulator. It is mounted inside the pump shroud.
- Grasp the filter bowl and depress the release button. Pull straight down and remove the filter bowl from the air regulator. See Figure 17.
- Drain any accumulated water from the filter bowl. Remove any dirt or debris. Wipe the filter bowl clean.
- A filter element is located inside the air regulator housing. Using a clean rag, wipe off any loose dirt or dust from the filter element.

NOTICE If the filter element is very dirty, or if the filter bowl is damaged, replace the entire filter/regulator. Replacement parts are not available from Enerpac for this device. Order complete filter/regulator unit. Refer to pump repair parts sheet for filter/regulator part number.

- Reinstall the filter bowl in the air regulator. Be sure it locks into place.
- Reconnect the air supply hose to the pump air inlet connection. Test pump operation without load before placing the pump back into service.

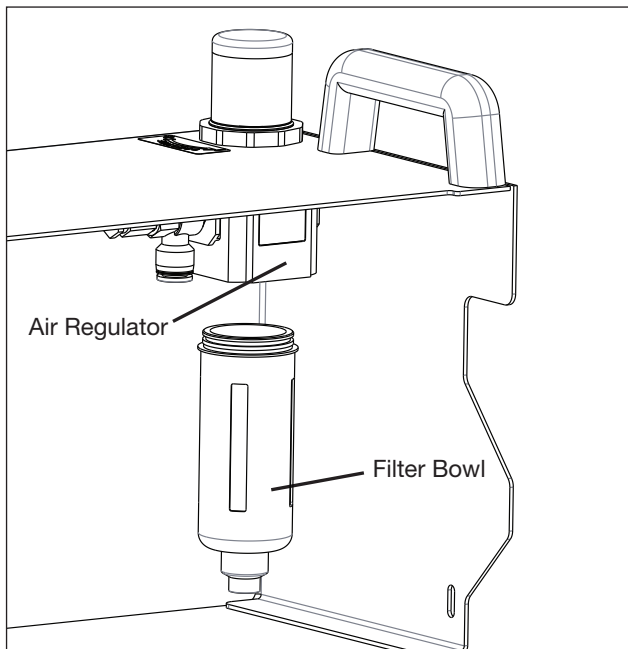

Figure 17 - Air Regulator and Filter Bowl

8.5 Air Shuttle Valve Routine Maintenance

The pump air shuttle valve is located on the right-hand side of the pump element (when the pump is viewed from the rear). The valve end cap and piston must be inspected, cleaned and lubricated at the recommended time interval to ensure optimum pump operation.

NOTICE Disassemble and inspect the pump air shuttle valve at least every 100,000 cycles.

Refer to Figure 18 during the following procedures.

8.5.1 Disassembly

1. Fully relieve pressure in the pneumatic and hydraulic circuits. Disconnect hoses. Remove pump shroud. Refer to maintenance preparation procedures in Section 8.1 of this manual. Also refer to pressure relief procedures in Section 6.3.
2. To aid end cap removal, install an M5 bolt (user supplied) in the tapped center hole of the end cap.

⚠ WARNING A small amount of pressurized trapped air may be present under the end cap. End cap may eject suddenly as it is being removed, even if the pump air pressure gauge indicates zero (0) psi/bar. To prevent possible eye injury, wear safety goggles during disassembly procedures.

3. Using a snap ring pliers, remove the snap ring.
4. Using a suitable needle nose pliers, grasp the head of the M5 bolt. Pull straight up and remove the end cap from the bore of the shuttle valve assembly.
5. Remove the M5 bolt from the end cap and reinstall it in the tapped center hole of the piston.
6. Using a suitable needle nose pliers, grasp the head of the M5 bolt. Pull straight up and remove the piston from the bore of the shuttle valve assembly.

8.5.2 Inspection

1. Using a clean, lint free rag, remove the old grease lubricant from piston, end cap, and from the valve assembly bore.
2. Inspect piston and end-cap for excessive wear, nicks, scratches, corrosion or other problems.

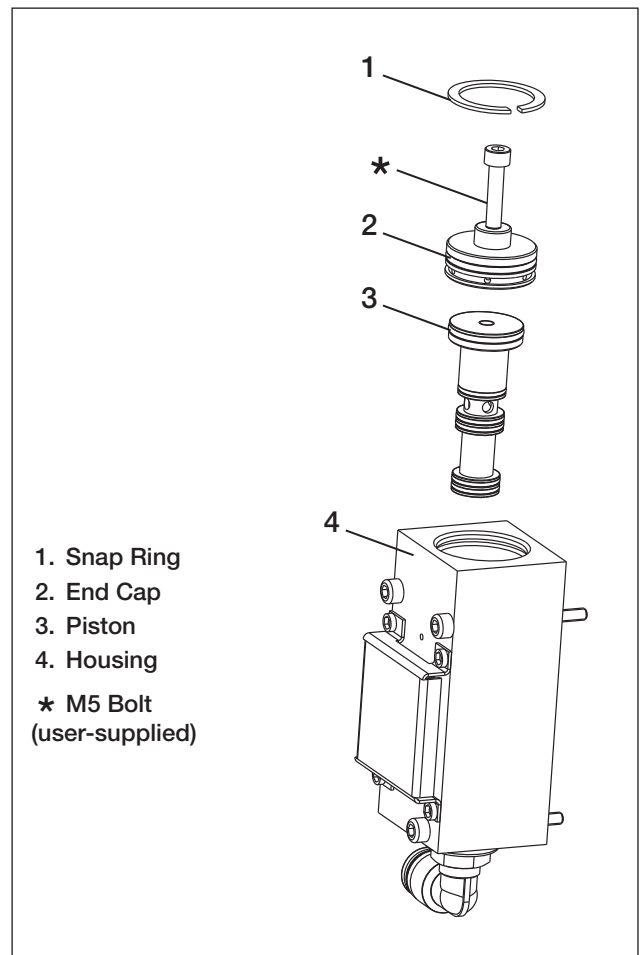

Figure 18 - Air Shuttle Valve Components

3. Check the condition of all piston seals. Replace entire piston assembly if seals are worn or damaged.

NOTICE If obvious wear or damage is indicated, replace the entire air shuttle valve assembly. Individual components and seals are not sold separately.

8.5.3 Reassembly

1. Using a small brush, lubricate the O-rings and seals on the piston with lithium grease.
2. If removed, re-install the M5 bolt in the tapped center hole of the piston.
3. Align the piston with the bore opening and carefully reinstall it in the bore.
4. Using a suitable needle nose pliers, apply firm pressure to the head of the M5 bolt until the piston has bottomed out in the bore of the housing. Then, unscrew and remove the M5 bolt.
5. Align the end cap with the bore opening and position it in the bore.
6. Using a suitable needle nose pliers, apply firm pressure to the end cap until it has bottomed-out, and is located just below the snap ring groove.
7. Using a snap ring pliers, reinstall the snap ring.

8.6 Pump Element Air Switch Maintenance

The pump element contains two air switches, one located on each side of the pump element. The air switches must be inspected, cleaned and lubricated at the recommended time interval to ensure optimum pump performance.

NOTICE Disassemble and inspect the pump air switches at least every 100,000 cycles.

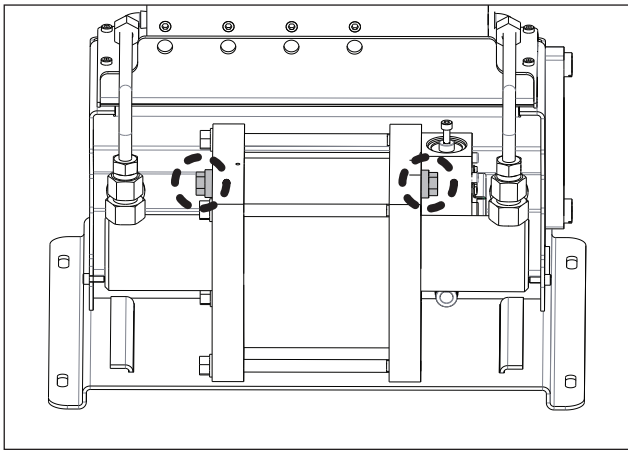

Figure 19 - Air Switches
(viewed with shroud removed)

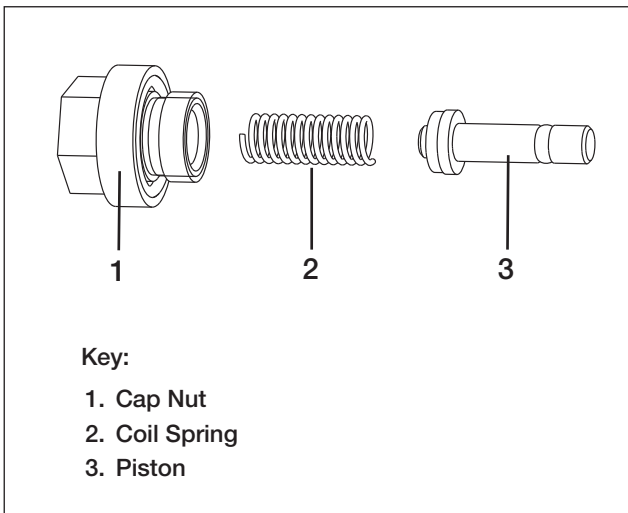

Figure 20 - Air Switch - Exploded View

Always perform maintenance procedures for BOTH air switches. Follow the instructions in sections 8.6.1 through 8.6.3 for each air switch. Refer to Figures 19 and 20.

8.6.1 Disassembly

1. Fully relieve pressure in the pneumatic and hydraulic circuits. Disconnect hoses. Remove pump shroud. Refer to maintenance preparation procedures in Section 8.1 of this manual. Also refer to pressure relief procedures in Section 6.3.
2. Using an adjustable wrench, loosen and remove the air switch cap nut.
3. Using a right-angle needle nose pliers, grasp the end of the air switch piston and carefully pull it straight out of the air switch bore.
4. If it was not removed with the piston, remove the coil spring.

8.6.2 Inspection

1. Using a clean, lint free rag, remove old grease lubricant from the air switch bore, the piston and the coil spring.
2. Inspect piston for obvious wear, nicks, scratches, corrosion or other problems. Recondition or replace piston as required.
3. Check the condition of both piston seals. Replace entire piston assembly if seals are worn or damaged.

NOTICE If obvious wear or damage is indicated, replace the entire air switch assembly. Individual components and seals are not sold separately.

4. Inspect the coil spring. Replace if broken, bent or obviously worn. Refer to pump repair parts list for part number.

8.6.3 Reassembly

1. Using a small brush, lubricate the piston surface, O-rings and seals with lithium grease.
2. Place the coil spring around the piston.
3. Carefully place the piston and coil spring into the air switch bore.
4. Engage the threads on the cap nut with the threads in the air switch bore. Using a wrench, tighten the end cap snug tight.

8.7 Air Exhaust Muffler

The pump air shuttle valve contains a muffler assembly. The muffler felt must be replaced at the recommended time interval to ensure optimum pump performance.

NOTICE Replace the muffler felt at least every 100,000 cycles.

Replace the air exhaust muffler felt as described in the following steps:

1. Fully relieve pressure in the pneumatic and hydraulic circuits. Disconnect hoses. Remove pump shroud. Refer to maintenance preparation procedures in Section 8.1 of this manual. Also refer to pressure relief procedures in Section 6.3.
2. Loosen and remove the four screws securing the cover to the air shuttle valve. See Figure 21.
3. Remove the cover. Remove and discard the old muffler felt.

NOTICE Exhaust muffler felt is not purchasable from Enerpac, but is available from many pneumatic maintenance supply distributors.

4. Place the new muffler felt inside the cover.
5. Position the cover plate against the air shuttle valve and secure it with four screws.

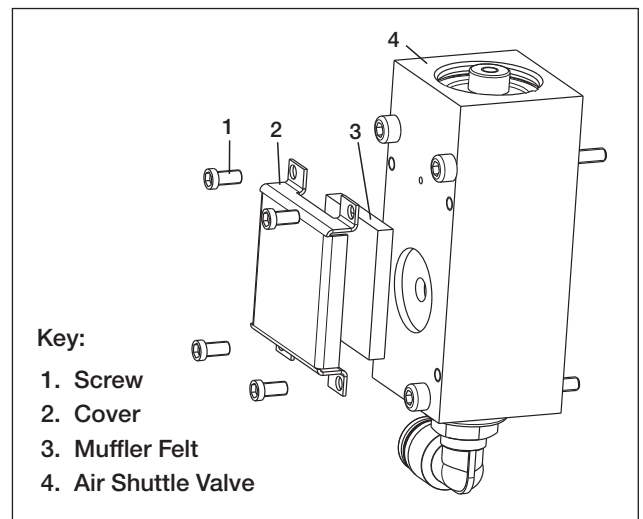

Figure 21 - Air Exhaust Muffler

9.0 TROUBLESHOOTING

Refer to the troubleshooting guide when diagnosing pump operational problems. Please note that the troubleshooting guide is not all-inclusive, and should be considered only as an aid to help diagnose the most common possible problems.

For repair service, contact your nearest Enerpac Authorized Service Center. As required, also refer to the troubleshooting information provided with your hydraulic control valves and other system components.

TROUBLESHOOTING GUIDE		
Problem	Possible Cause	Action
Pump does not cycle.	No air pressure at supply.	Check air supply.
	Pump air-shutoff valve closed.	Open pump air-shutoff valve.
	Pump air pressure regulator set too low.	Check pressure regulator setting.
	Pump air exhaust muffler dirty.	Clean or replace the muffler felt. Refer to Section 8.7 of this manual.
	Pump air shuttle valve needs cleaning and lubrication.	Refer to procedure in Section 8.5 of this manual.
	Pump air motor worn or damaged.	Contact Enerpac Authorized Service Center.
	Pump element jammed.	Contact Enerpac Authorized Service Center.
Pump fails to build hydraulic pressure or builds less than desired pressure.	Low air pressure or volume at air supply.	Check air supply.
	Pump air pressure regulator set too low.	Check regulator setting.
	Pump air exhaust muffler dirty.	Clean or replace the muffler felt. Refer to Section 8.7 of this manual.
	Control valve returning oil to reservoir.	Change position of control valve.
	Low oil level in reservoir.	Check oil level. Add oil as required.
	Pump suction strainer elements dirty.	Replace pump suction strainer elements. Refer to Section 8.3 of this manual.
	Oil leakage at hydraulic hoses, fittings or connected devices.	Replace leaking components as required.
	Internal leakage in control valve or valve manifold.	Repair or replace components as required.
	Internal leakage in pump element. Pump element worn or damaged.	Contact Enerpac Authorized Service Center.
Jerky or erratic pump operation.	Low air pressure or volume at plant air supply.	Check plant air supply.
	Air in hydraulic lines.	Remove air as described in Section 5.10 of this manual.
	Hydraulic oil dirty.	Change hydraulic oil. Use Enerpac HF oil. Refer to Section 8.2 of this manual.
	Low oil level in reservoir.	Check oil level. Add oil as required. Refer to sections 5.3 and 5.4 of this manual.
	Pump suction strainer elements dirty.	Replace pump suction strainer elements. Refer to Section 8.3 of this manual.
	Internal leakage in pump element. Pump element worn or damaged.	Contact Enerpac Authorized Service Center.
Pump Noise.	Low air pressure or volume at air supply.	Check air supply.
	Pump air pressure regulator set too low.	Check regulator setting. Refer to Section 5.9 of this manual.
	Pump air exhaust muffler dirty.	Clean or replace the muffler felt. Refer to Section 8.7 of this manual.
Oil leakage	Loose connections.	Tighten loose connections. Replace any worn or damaged connectors.
	Worn or damaged components.	Repair or replace components as required.

(continued on next page)

TROUBLESHOOTING GUIDE (continued)

Problem	Possible Cause	Action
Excessive moisture in pump exhaust.	Excessive water and/or lubricant in supply air.	Reduce moisture in air. Install water separator. Note: Pump components are self-lubricating. Lubricated air is permitted, but not required.
	Pump air filter bowl needs draining.	Check bowl for water. Drain as required. Refer to Section 8.4 of this manual.
	Pump air filter dirty.	Clean air filter element. Refer to Section 8.4 of this manual.
	Internal leakage in pump element. Pump element damaged or worn.	Contact Enerpac Authorized Service Center.
Low oil flow rate.	Reservoir not vented.	Open vent screw on reservoir. Refer to Section 5.7 of this manual.
	Pump air filter bowl needs draining.	Check bowl for water. Drain as required. Refer to Section 8.4 of this manual.
	Pump air filter dirty.	Clean air filter element. Refer to Section 8.4 of this manual.
	Internal leakage in pump element. Pump element worn or damaged.	Contact Enerpac Authorized Service Center.
	Low air pressure or volume at air supply.	Check air supply.
	Pump air pressure regulator set too low.	Check regulator setting. Refer to Section 5.9 of this manual.
	Pump suction strainer elements dirty.	Replace pump suction strainer elements. Refer to Section 8.3 of this manual.
Cylinder drift.	External system leak.	Repair or replace leaking components as required.
	Internal leak in system component.	Repair or replace leaking components as required.
Cylinder will not return.	Return flow blocked or restricted.	Check system for blockages and make repairs as required. Be sure that all couplers are fully connected.
	Control valve malfunction.	Repair or replace control valve as required.
Air leakage.	Loose air system connections.	Tighten connections as required.
	Worn or damaged air system components.	Repair or replace components as required.

ENERPAC 

www.enerpac.com