

L4241 Rev. A 11/18

<i>Table of Contents:</i>	
<i>Section</i>	<i>Page</i>
1.0 IMPORTANT RECEIVING INSTRUCTIONS . . . . .	1
2.0 SAFETY . . . . .	1
3.0 REPAIR PROCEDURES . . . . .	3
3.1 Pump Disassembly. . . . .	3
3.2 Pump Element Disassembly. . . . .	3
3.3 Piston Seal Removal . . . . .	4
3.4 Piston Seal Replacement. . . . .	4
3.5 End Cap Seal Removal and Replacement. . . . .	4
3.6 Rod Seal Removal . . . . .	4
3.7 Rod Seal Replacement. . . . .	5
3.8 Pump Element Reassembly . . . . .	5
3.9 Pump Installation . . . . .	5
4.0 REPAIR PARTS INFORMATION . . . . .	6



Safety Alert Symbols are used in conjunction with certain Signal Words that call attention to safety messages or property damage messages and designate a degree or level of hazard seriousness. The Signal Words used in this manual are WARNING, CAUTION and NOTICE.

**1.0 IMPORTANT RECEIVING INSTRUCTIONS**

Visually inspect all components for shipping damage. Shipping damage is not covered by warranty. If shipping damage is found, notify carrier at once. The carrier is responsible for all repair and replacement costs resulting from damage in shipment.

**2.0 SAFETY**

**2.1 Introduction**

Read all instructions carefully. Follow all recommended safety precautions to avoid personal injury as well as damage to the product and/or damage to other property. Enerpac cannot be responsible for any damage or injury from unsafe use, lack of maintenance or incorrect operation. Do not remove warning labels, tags, or decals. In the event any questions or concerns arise, contact Enerpac or a local Enerpac distributor for clarification.

If you have never been trained on high-pressure hydraulic safety, consult your distributor or service center for information about an Enerpac Hydraulic Safety Course.

This manual follows a system of safety alert symbols, signal words and safety messages to warn the user of specific hazards. Failure to comply with these warnings could result in death or serious personal injury, as well as damage to the equipment or other property.

 The **Safety Alert Symbol** appears throughout this manual. It is used to alert you to potential physical injury hazards. Pay close attention to Safety Alert Symbols and obey all safety messages that follow this symbol to avoid the possibility of death or serious personal injury.

 **WARNING** Indicates a hazardous situation that, if not avoided, **could** result in death or serious personal injury.

 **CAUTION** Indicates a hazardous situation that, if not avoided, **could** result in minor or moderate personal injury.

 **NOTICE** Indicates information considered important, but not hazard related (e.g. messages relating to property damage). Please note that the Safety Alert Symbol will **not** be used with this signal word.

**2.2 Hydraulic Pump Safety Precautions (DuroTech Series)**

 **WARNING**

**Failure to observe and comply with the following precautions could result in death or serious personal injury. Property damage could also occur.**

- Read and completely understand the safety precautions and instructions in this manual before operating the pump or preparing it for use. Always follow all safety precautions and instructions, including those that are contained within the procedures of this manual.
- Operating procedures will vary, depending on the system arrangement and the specific components being used. Always read, follow and completely understand all manufacturer's instructions when operating cylinders, valves and any other hydraulic devices used with the pump. Follow all safety precautions contained in the manufacturer's manuals.



- Always wear appropriate personal protective equipment (P.P.E.) when operating hydraulic equipment. Be sure to wear eye protection, work gloves and protective clothing. Use of additional P.P.E. safety items such as dust mask, non-skid safety shoes, hard hat, and hearing protection (used as appropriate for the conditions) will reduce the chance of personal injuries. The use of these items may also be required by local regulations or laws.
- Do not handle pressurized hoses. Escaping oil under pressure can penetrate the skin. If oil is injected under the skin, see a doctor immediately.
- Do not pressurize disconnected couplers.
- Only use hydraulic cylinders in a coupled system. Never use a cylinder with uncoupled couplers. If the cylinder becomes extremely overloaded, components can fail catastrophically, causing severe personal injury.
- The pump is equipped with a hydraulic safety relief valve that is factory preset to the pump's maximum operating pressure. DO NOT attempt to adjust, bypass or alter the safety relief valve. This valve is not user-adjustable. Adjustment should be performed only by an Enerpac Authorized Service Center.
- The system operating pressure must not exceed the pressure rating of the lowest rated component in the system. Refer to the instruction sheet provided with your pump for the maximum rated working pressure for your pump model.
- Install pressure gauge(s) in the system to monitor operating pressure. It is your window to see what is happening in the system.
- Never set the pump hydraulic pressure to a higher setting than the maximum rating of the hoses and connected devices. The pressure setting should not exceed the setting of the lowest rated component (pump, cylinder or other hydraulic component) in the circuit.
- Do not exceed equipment ratings. Overloading may cause equipment failure and possible personal injury.
- Always perform a visual inspection of the pump before placing it into operation. If any problems are found, do not use the pump. Have the pump repaired and tested before it is returned to service.
- Fill the pump reservoir with hydraulic oil only to the recommended level. Fill only when cylinders (or other hydraulic actuators) are in their normal de-energized position.
- Never use the pump if it is leaking oil. Do not use the pump if it is damaged, has been altered or is in need of repair.
- Always lift the pump using only the provided lifting handles.
- Allow only trained and experienced personnel to operate the pump.
- Be certain that hydraulic pressure is fully relieved from the cylinder (or other hydraulic actuator) before disconnecting hydraulic hoses, loosening hydraulic fittings, or performing any disassembly or repair procedures.
- If hydraulic equipment is damaged, do not touch or go near any area where high-pressure oil is spraying. Promptly stop usage of the hydraulic equipment and replace the damaged parts with new ones before using the equipment again.
- Do not put your hands or body in line with the face of a disconnected coupler. If the coupler becomes pressurized and leakage occurs, the high-pressure oil stream could penetrate the skin.
- Skin penetration from high-pressure hydraulic oil can result in death or serious personal injury. If oil is injected under the skin, see a doctor immediately.

**Failure to observe and comply with the following precautions could result in minor or moderate personal injury. Property damage could also occur.**

- Be careful to avoid damaging hydraulic hoses. Avoid sharp bends and kinks when routing hydraulic hoses. Do not exceed the minimum bend radius specified by the hose manufacturer. Using a bent or kinked hose will cause severe back-pressure. Sharp bends and kinks will internally damage the hose, leading to premature hose failure.
- Do not drop heavy objects on hoses. A sharp impact may cause internal damage to hose wire strands. Applying pressure to a damaged hose may cause it to rupture.
- Do not lift hydraulic equipment by the hoses or couplers.
- Make sure that all system components are protected from external sources of damage, such as moving machine parts, sharp edges and corrosive chemicals.
- Keep hydraulic equipment away from flames. Flames near a hydraulic oil leak could cause the hydraulic oil to ignite, resulting in a fire.
- For optimum performance, do not expose hydraulic equipment to temperatures of 150°F [65°C] or higher. Excessive heat will soften packings and seals, resulting in possible hydraulic fluid leaks.
- Protect all hydraulic equipment from weld spatter.
- Protect the pump against rain, mud, dust, and humidity when using it outdoors.
- Disconnect air supply hose when pump is not in use for a prolonged period of time. NEVER remove a swivel air connector while the air hose is pressurized.
- Immediately replace worn or damaged parts with genuine Enerpac parts. Enerpac parts are designed to fit properly and to withstand high loads. Non-Enerpac parts may break or cause the product to malfunction.

## NOTICE

- Hydraulic equipment must only be serviced by a qualified hydraulic technician. For repair service, contact the Enerpac Authorized Service Center in your area.
- To help ensure proper operation and best performance, use only genuine Enerpac hydraulic oil.

### 2.3 Additional Safety References

Consult the applicable industry and/or government standards in your country or region for additional safety precautions and work rules applicable to hydraulic pumps, hydraulic workholding devices and related components.

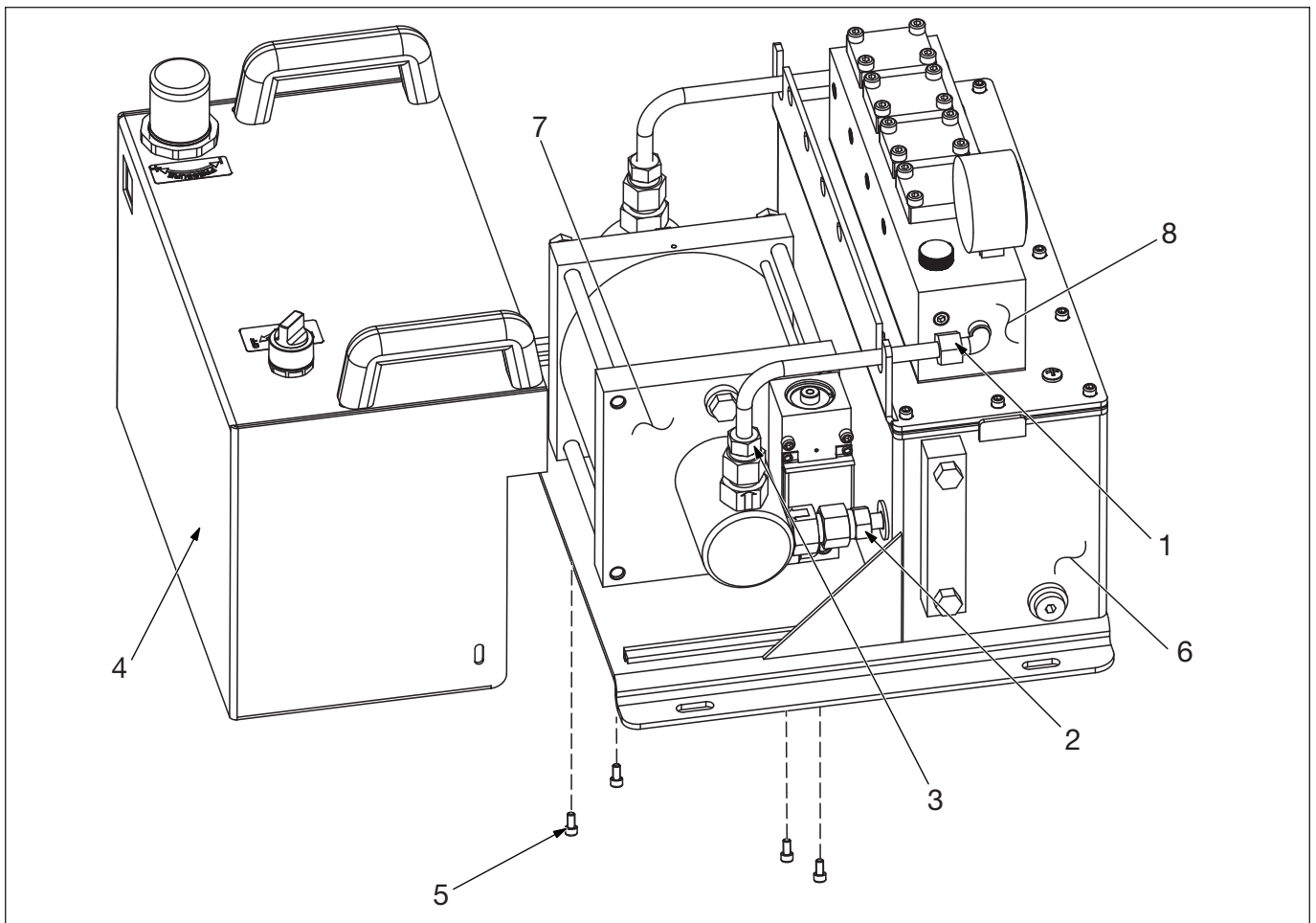

Figure 1, Pump Element Subassembly

### 3.0 REPAIR PROCEDURES

#### 3.1 Pump Disassembly

1. Fully relieve pressure in the pneumatic and hydraulic circuits. Disconnect hoses. Refer to maintenance preparation procedures in Section 8.1 of instruction sheet L4184.
2. Remove cover assembly (Figure 1, Item 4) from pump assembly. Refer to procedure in Section 6.3 of instruction sheet L4184.
3. Using a 3/4" [19 mm] box end wrench, disconnect the pipe-elbow connector (Figure 1, Item 1) from manifold assembly (Figure 1, Item 8).
4. Using a 3/4" [19 mm] box end wrench, disconnect the pipe-elbow connector (Figure 1, Item 3) from piston rod assembly (Figure 1, Item 7).
5. Remove elbow pipe from tank and manifold assemblies (Figure 1, Items 6 and 8).
6. Using a 3/4" [19 mm] box end wrench, disconnect connector (Figure 1, Item 2) from tank assembly (Figure 1, Item 6).
7. Repeat steps 3 through 6 for opposite side.
8. Remove four screws (Figure 1, Item 5) from bottom of tank assembly (Figure 1, Item 6).
9. Remove pump element subassembly (Figure 1, Item 7) from manifold and tank assemblies (Figure 1, Items 6 and 8).

#### 3.2 Pump Element Disassembly

1. Place pump element subassembly in a non-marring vise.
2. Remove four tie-rods (Figure 2, Item 2) from piston rod assembly (Figure 2, Item 1).
3. Using a soft mallet, separate the end caps (Figure 3, Item 1) from cylinder tube (Figure 3, Item 2).
4. Using a soft mallet, drive piston rod (Figure 3, Item 3) out of the cylinder tube (Figure 3, Item 2).

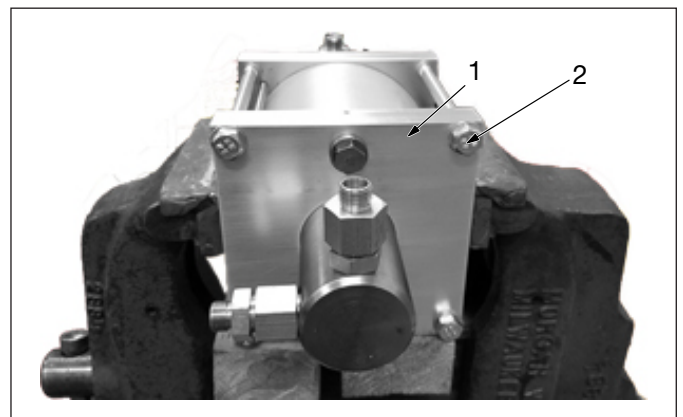

Figure 2, Tie Rod Removal (View 1 of 2)

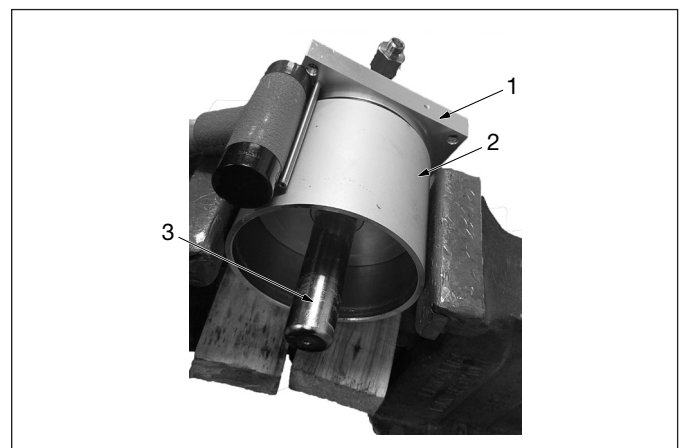
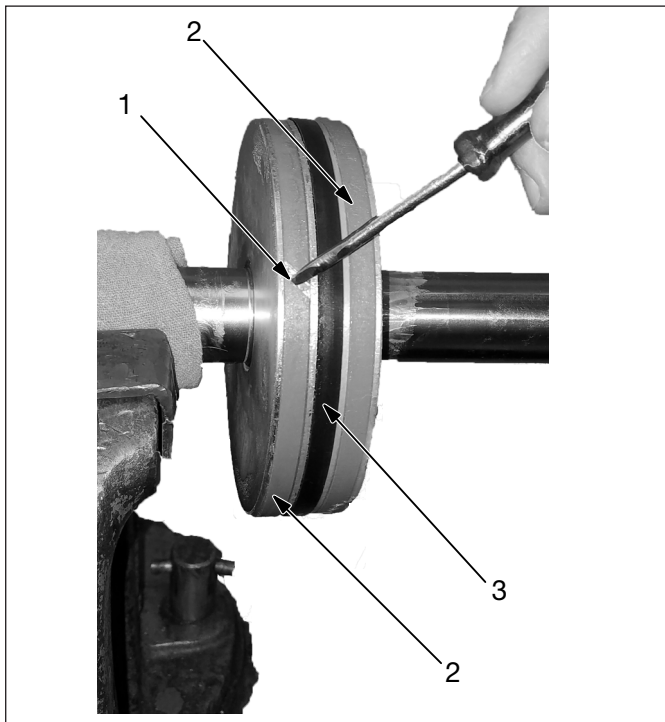

Figure 3, Tie Rod Removal (View 2 of 2)

**NOTICE** Some residual oil will be contained in cylinder tube. Dispose of any used oil in accordance with all applicable laws and regulations.

### 3.3 Piston Seal Removal

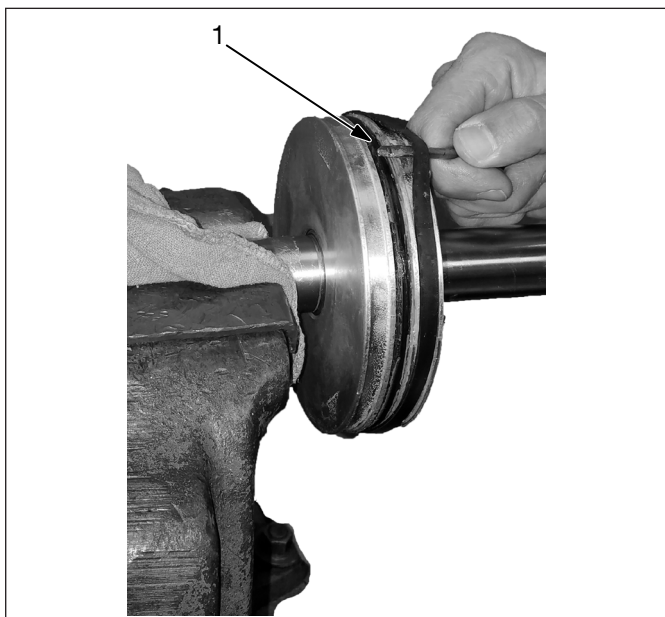

**Figure 4, Piston Seal Removal (View 1 of 2)**

1. Place the pump on a workbench or other substantial work surface.
2. Pry and remove wear band (Figure 4, Item 2) starting at the scarf cut (Figure 4, Item 1).
3. Repeat step 1 for second wear band.
4. Using same non-marring blade, pry up outer piston seal (Figure 4, Item 3). While retaining the seal with blade, rotate the blade around the piston until the outer piston seal is loose. Remove outer piston seal.
5. Remove inner piston seal O-ring (Figure 5, Item 1) that was exposed in step 4.

### 3.4 Piston Seal Replacement

1. Using a clean, lint-free rag, remove old grease and seals (Figure 4, Item 1) from end cap (Figure 4, Item 2).



**Figure 5, Piston Seal Removal (View 2 of 2)**

2. Using a small brush, lightly grease piston grooves and seals before installation.
3. Install inner piston seal O-ring (Figure 5, Item 1) on piston.
4. Install outer piston seal (Figure 4, Item 3) on top of inner piston seal O-ring (Figure 5, Item 1).
5. Install wear band on piston (Figure 4, Item 2).

### 3.5 End Cap Seal Removal and Replacement

Perform steps 1 through 3 for each end cap:

1. Using a clean, lint-free rag and suitable cleaning agent, remove old grease and seal (Figure 6, Item 1) from end cap (Figure 6, Item 2).

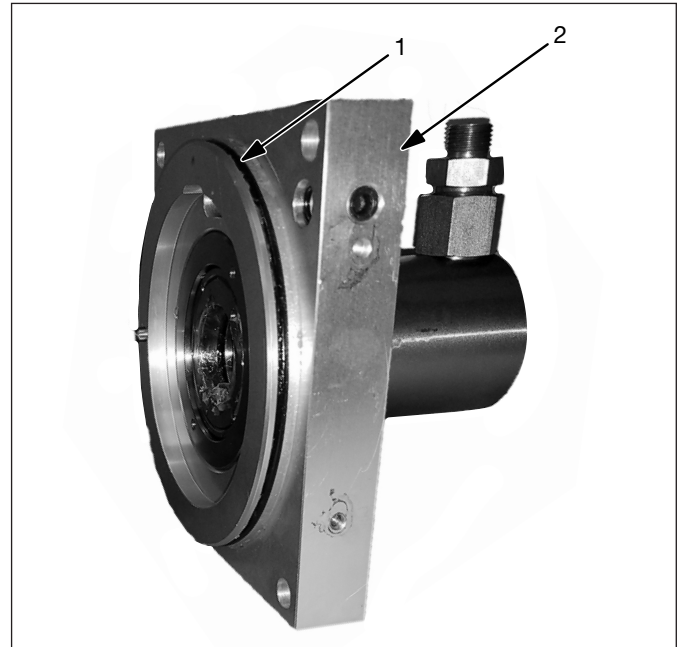
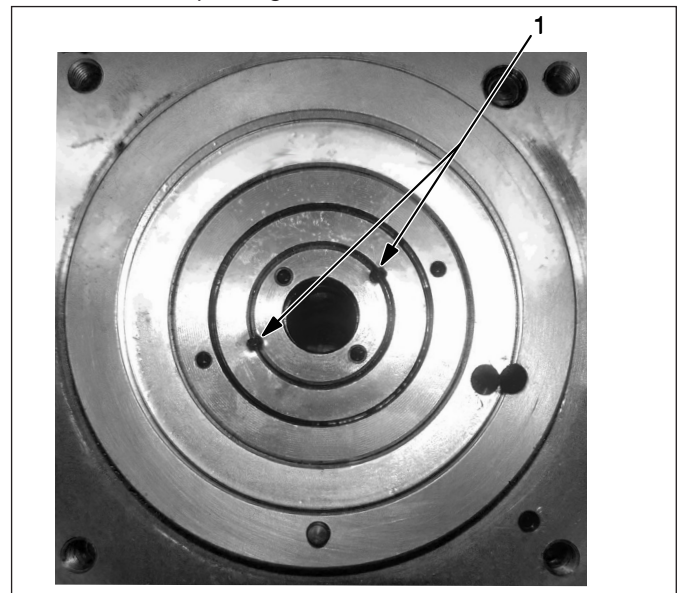

**Figure 6, End Cap Seal Removal**

2. Using a small brush, lightly grease grooves and seals before installation.
3. Install end cap seal on end cap with care so as not to tear the seal.

### 3.6 Rod Seal Removal

1. Secure end cap assembly in a non-marring vise with the seals accessible.
2. Identify the two peening indentations (Figure 7, Item 1).
3. Using a 1/8" inch drill bit, drill an approximately 1/8" deep hole at each peening indentation.



**Figure 7, Peening Indentations**

- Using a spanner wrench, remove stop ring, guide ring, and O-ring (Figure 8, Item 1) from end cap assembly.

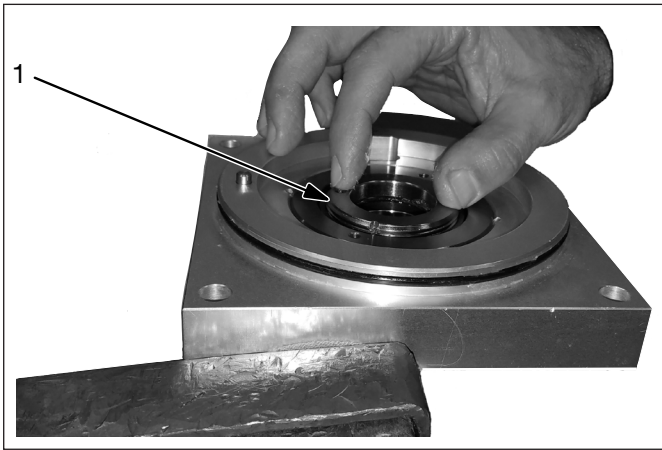

**Figure 8, Stop Ring, Guide Ring and O-ring (View 1 of 2)**

**NOTICE** To prevent permanent damage to pump components when parts are reinstalled, be certain that all old grease and drilling debris is completely removed as described in step 5.

- Using a clean, lint-free rag, remove all old grease and drilling debris from end cap assembly.
- Separate stop ring, guide ring and O-ring (Figure 9, Items 1, 2 and 3) that were removed in step 4. Discard O-ring (Figure 9, Item 2).

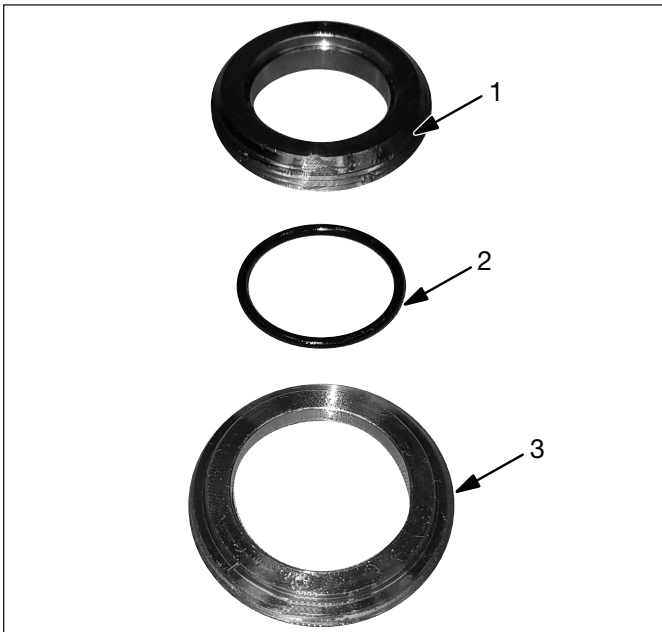

**Figure 9, Stop Ring, Guide Ring, and O-ring (View 2 of 2)**

- Remove U-cup (Figure 10, Item 1) and O-ring (Figure 10, Item 2).

### 3.7 Rod Seal Replacement

- Using a small brush, lightly grease grooves and seals before installation.
- Install O-ring (Figure 10, Item 1).
- Install U-cup (Figure 8, Item 1) in end cap.
- With a spanner wrench, install stop ring, guide ring and O-ring (Figure 9, Items 1, 2 and 3).
- Tighten until snug.

### 3.8 Pump Element Reassembly

- Place cylinder tube in a non-marring vise.
- Using a soft mallet, drive piston rod (Figure 3, Item 3) into the cylinder tube (Figure 3, Item 2).

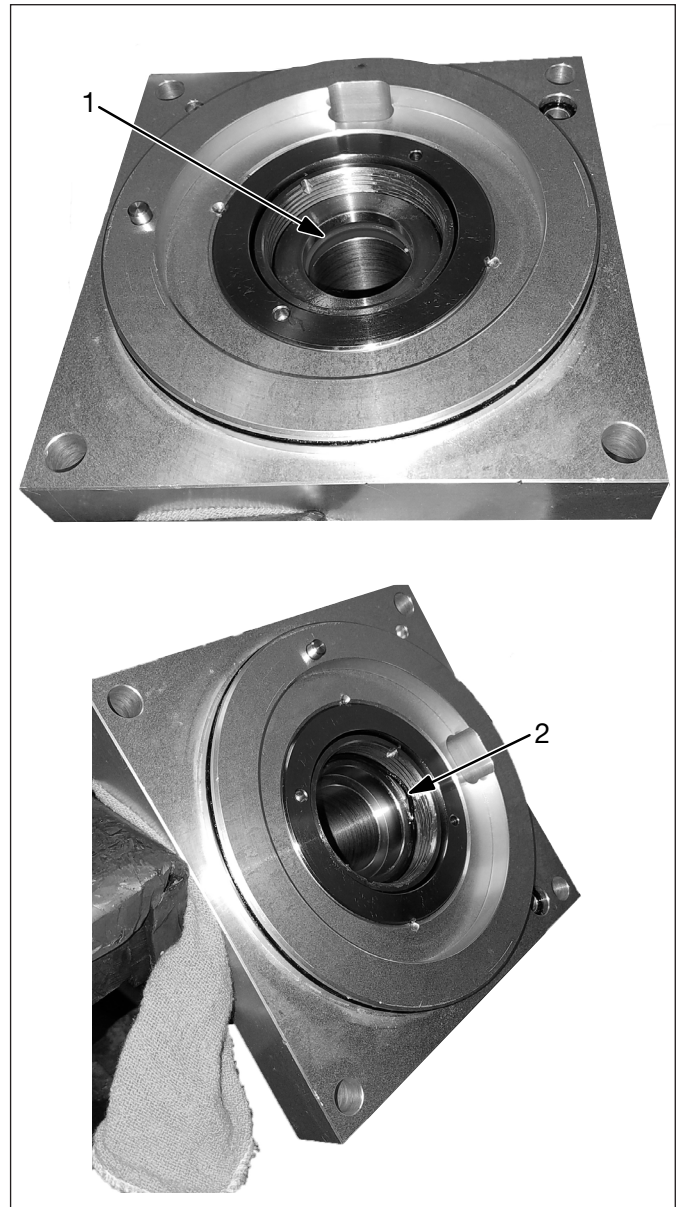

**Figure 10, U-cup and O-ring**

- Using a soft mallet, press the end caps (Figure 3, Item 1) onto the cylinder tube (Figure 3, Item 2).
- Install four tie-rods (Figure 2, Item 2) on piston rod assembly (Figure 2, Item 1).
- Torque tie-rods to 18-20 ft-lbs [25-30 Nm].

### 3.9 Pump Installation

- Install piston rod assembly (Figure 1, Item 7) on manifold and tank assemblies (Figure 1, Items 6 and 8) with four screws (Figure 1, Item 5).
- Tighten screws to 7.4-11 ft-lbs [10-15 Nm].
- Install elbow-pipe from tank and manifold assemblies (Figure 1, Items 6 and 8).
- Using a 3/4" [19 mm] box end wrench, tighten the pipe-elbow connector (Figure 1, Item 1) onto manifold assembly (Figure 1, Item 8).
- Using an adjustable or 3/4" [19 mm] box wrench, tighten the pipe-elbow connector (Figure 1, Item 3) onto piston rod assembly (Figure 1, Item 7).
- Using a 3/4" [19 mm] box end wrench, tighten connector (Figure 1, Item 2) onto tank assembly (Figure 1, Item 6).
- Repeat steps 3 through 6 for opposite side.
- Install cover assembly (Figure 1, Item 4) onto pump assembly. Refer to procedure in Section 6.3 of instruction sheet L4184.

#### 4.0 REPAIR PARTS INFORMATION

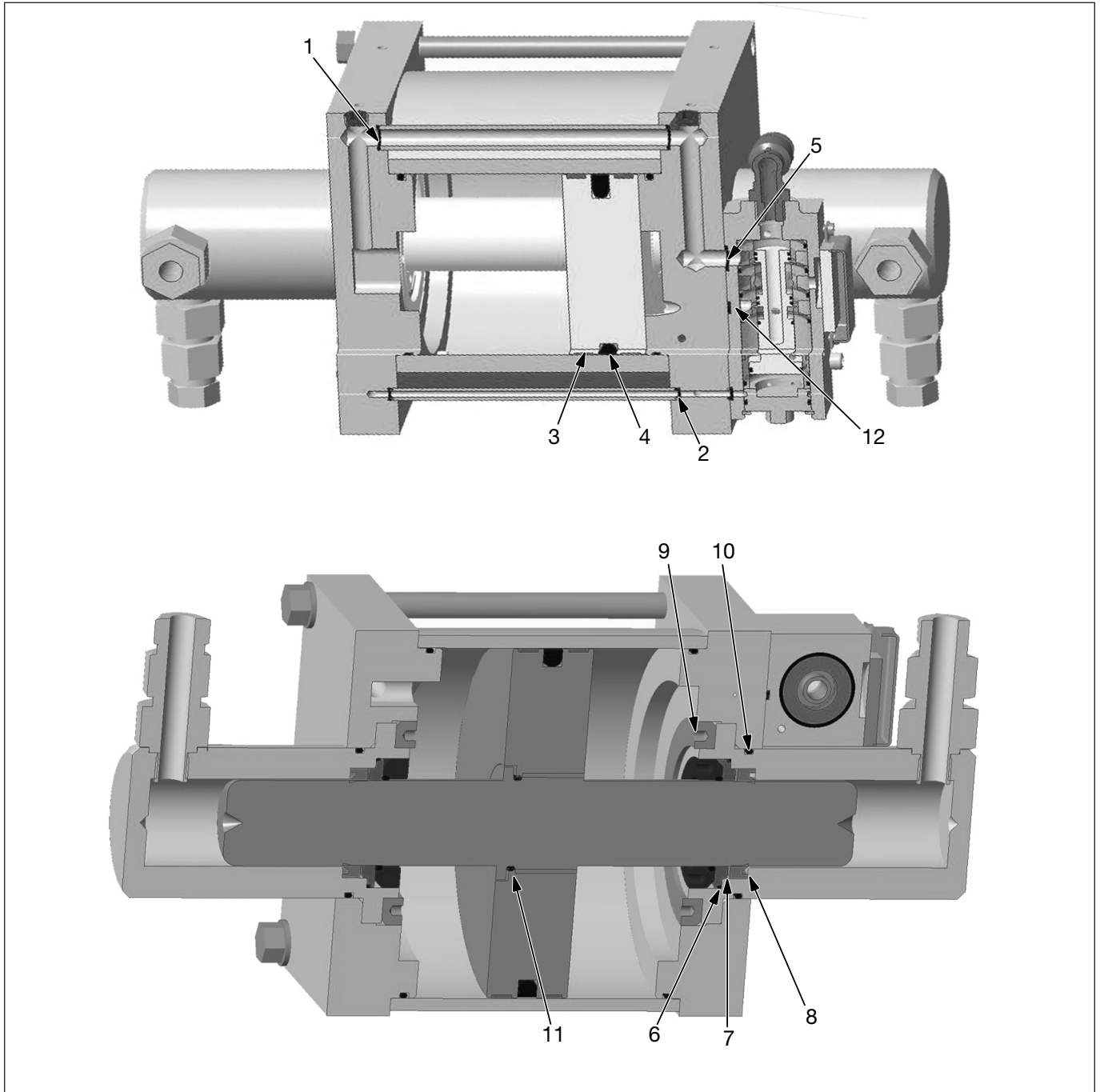

Figure 11, Pump Element Seals

Parts List for Figure 11

Item	Part Number	Qty.	Description	Item	Part Number	Qty.	Description
1	◆ DX9158503	2	O-ring	8	◆ DX7034514	2	GT Ring (WAP07)
2	◆ DX9157503	2	O-ring		◆ DX7034514-2	2	GT Ring (WAP15)
3	◆ DX7071155	2	Wear Ring		◆ DX7034514-4	2	GT Ring (WAP30)
4	◆ DX7070503	1	O-ring	9	◆ DX7037449	2	Retaining Ring (WAP07)
5	◆ DX7048503	3	O-ring		◆ DX7037449-2	2	Retaining Ring (WAP15)
6	◆ DX7038503	2	O-ring (WAP07)		◆ DX7037449-3	2	Retaining Ring (WAP30)
	◆ DX7038503-2	2	O-ring (WAP15)	10	◆ DX7036503	2	O-ring (WAP07)
	◆ DX7038503-3	2	O-ring (WAP30)		◆ DX7036503-2	2	O-ring (WAP15)
7	◆ DX7035338	2	GT Ring Mount (WAP07)		◆ DX7036503-3	2	O-ring (WAP30)
	◆ DX7035338-2	2	GT Ring Mount (WAP15)	11	◆ DX7038503	1	O-ring
	◆ DX7035338-3	2	GT Ring Mount (WAP30)	12	◆ DX7060503	2	O-ring

◆ Items are available in seal kit WAP pump seal kit (DX1701900SR).



