

Specifications

Units: **Imperial** Metric

Maximum Operating Pressure (psi)	10,000
For Use With Torque Wrenches	For use with all Enerpac torque wrenches
Reservoir Capacity (in ³)	277
Usable Oil Capacity (gal)	1
Maximum Flow at Rated Pressure	60 in ³ /min
Output Flow Rate (in ³ /min) 100 psi	700
Output Flow Rate (in ³ /min) 700 psi	535
Output Flow Rate (in ³ /min) 5000 psi	76
Output Flow Rate (in ³ /min) 10000 psi	60
Motor Size (hp)	1.7
Motor Hertz	50/60 Hz
Motor Phases	1 Ph
Motor Voltage	115 V
Duty Cycle	Intermittent
Valve Operation	Solenoid
Valve Type	4-way, 2-position
Power Source	Electric
Pump Control	Pendant
Motor Electrical Specification	115 V, 1 Ph, 50/60 Hz
Weight (lbs)	70

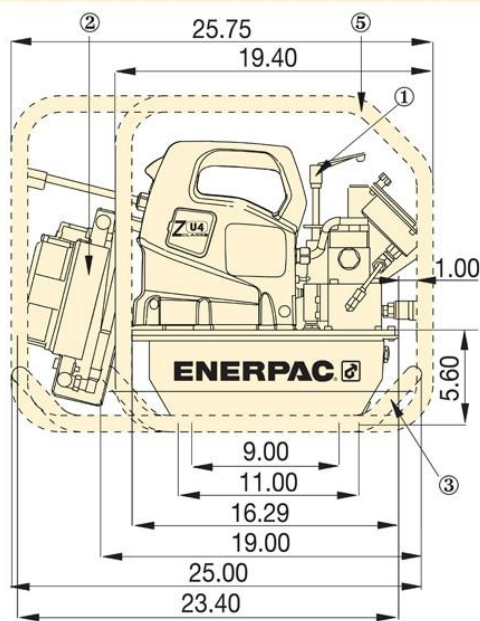

ZU4-Series Torque Wrench Pumps

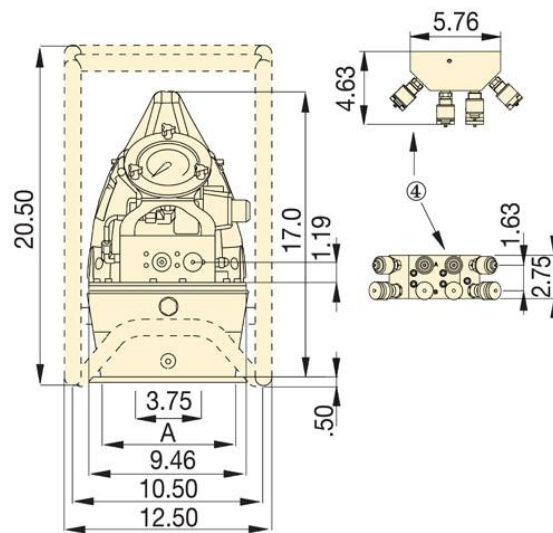

Dimensions shown in inches

- ① User adjustable relief valve
- ② Heat exchanger (optional)
- ③ Skidbar (optional)
- ④ 4-wrench manifold (optional)
- ⑤ Roll cage (optional)