

L2615

Rev. C

08/07

Index:

English	1-3
Français	4-7
Deutsch	8-11
Italiano	12-15
Español	16-19
Nederlands	20-23
Portuguese	24-27
Finnish	28-31
Norwegian	32-34
Swedish	35-37
中文	38-40
日本語	41-43

Repair Parts Sheets for this product are available from the Enerpac web site at www.enerpac.com, or from your nearest Authorized Enerpac Service Center or Enerpac Sales office.

1.0 IMPORTANT RECEIVING INSTRUCTIONS

Visually inspect all components for shipping damage. Shipping damage is **not** covered by warranty. If shipping damage is found, notify carrier at once. The carrier is responsible for all repair and replacement costs resulting from damage in shipment.

SAFETY FIRST

2.0 SAFETY ISSUES



Read all instructions, warnings and cautions carefully. Follow all safety precautions to avoid personal injury or property damage during system operation. Enerpac cannot be responsible for damage or injury resulting from unsafe product use, lack of maintenance or incorrect product and/or system operation. Contact Enerpac when in doubt as to the safety precautions and operations. If you have never been trained on high-pressure hydraulic safety, consult your distribution or service center for a free Enerpac Hydraulic safety course.

Failure to comply with the following cautions and warnings could cause equipment damage and personal injury.

A **CAUTION** is used to indicate correct operating or maintenance procedures and practices to prevent damage to, or destruction of equipment or other property.

A **WARNING** indicates a potential danger that requires correct procedures or practices to avoid personal injury.

A **DANGER** is only used when your action or lack of action may cause serious injury or even death.



WARNING: Wear proper personal protective gear when operating hydraulic equipment.



WARNING: Stay clear of loads supported by hydraulics. A cylinder, when used as a load lifting device, should never be used as a load holding device. After the load has been raised or lowered, it must always be blocked mechanically.



WARNING: USE ONLY RIGID PIECES TO HOLD LOADS. Carefully select steel or wood blocks that are capable of supporting the load. Never use a hydraulic cylinder as a shim or spacer in any lifting or pressing application.



DANGER: To avoid personal injury keep hands and feet away from cylinder and workpiece during operation.



WARNING: Do not exceed equipment ratings. Never attempt to lift a load weighing more than the capacity of the cylinder. Overloading causes equipment failure and possible personal injury. The cylinders are designed for a max. pressure of 700 bar [10,000 psi]. Do not connect a jack or cylinder to a pump with a higher pressure rating.



Never set the relief valve to a higher pressure than the maximum rated pressure of the pump. Higher settings may result in equipment damage and/or personal injury.



WARNING: The system operating pressure must not exceed the pressure rating of the lowest rated component in the system. Install pressure gauges in the system to monitor operating pressure. It is your window to what is happening in the system.



CAUTION: Avoid damaging hydraulic hose. Avoid sharp bends and kinks when routing hydraulic hoses. Using a bent or kinked hose will cause severe back-pressure. Sharp bends and kinks will internally damage the hose leading to premature hose failure.



Do not drop heavy objects on hose. A sharp impact may cause internal damage to hose wire strands. Applying pressure to a damaged hose may cause it to rupture.



IMPORTANT: Do not lift hydraulic equipment by the hoses or swivel couplers. Use the carrying handle or other means of safe transport.



CAUTION: Keep hydraulic equipment away from flames and heat. Excessive heat will soften packings and seals, resulting in fluid leaks. Heat also weakens hose materials and packings. For optimum performance do not expose equipment to temperatures

of 65°C [150°F] or higher. Protect hoses and cylinders from weld spatter.



DANGER: Do not handle pressurized hoses. Escaping oil under pressure can penetrate the skin, causing serious injury. If oil is injected under the skin, see a doctor immediately.



WARNING: Only use hydraulic cylinders in a coupled system. Never use a cylinder with unconnected couplers. If the cylinder becomes extremely overloaded, components can fail catastrophically causing severe personal injury.



WARNING: BE SURE SETUP IS STABLE BEFORE LIFTING LOAD. Cylinders should be placed on a flat surface that can support the load. Where applicable, use a cylinder base for added stability. Do not weld or otherwise modify the cylinder to attach a base or other support.



Avoid situations where loads are not directly centered on the cylinder plunger. Off-center loads produce considerable strain on cylinders and plungers. In addition, the load may slip or fall, causing potentially dangerous results.



Distribute the load evenly across the entire saddle surface. Always use a saddle to protect the plunger.



IMPORTANT: Hydraulic equipment must only be serviced by a qualified hydraulic technician. For repair service, contact the Authorized ENERPAC Service Center in your area. To protect your warranty, use only ENERPAC oil.



WARNING: Immediately replace worn or damaged parts by genuine ENERPAC parts. Standard grade parts will break causing personal injury and property damage. ENERPAC parts are designed to fit properly and withstand high loads.

3.0 HYDRAULIC CONNECTIONS

3.1 Check All Coupler Connections

1. Use Enerpac hi-flow couplers for best results, or Enerpac regular couplers when very low flow pumps are used. (Maximum flow below 1 GPM — 230 cu. in./min.)
2. Connect hoses to valve at designated port locations. If using pipe sealants on male pipe threads, use sparingly and never over ends of fittings where it can be torn loose and get into system.

4.0 OPERATION

1. Connect and secure hoses and cylinders noting that the proper ports are connected.
2. Quick disconnects must be fully engaged and locking collars drawn up fully to ensure free flow of oil between valve and attached component.
3. Before starting pump rotate valve handle counter-

clockwise (CCW), viewed from the top, to open the valve to tank line. Pump can now be run but pressure will not build.

4. To build pressure, rotate the handle clockwise (CW) until the handle stops closing the valve. Pump can now build pressure. Rotation (CCW) will release the pressure and/or load and the decent is controlled by the amount of rotation.

NOTE: The VM22 and VM32 Enerpac valves are equipped with an integral user adjustable relief valve. This relief valve is factory set to 10,000 psi [700 bar]. The valve can be adjusted by first loosening the jam nut and either rotating the setscrew clockwise to increase system pressure or counter-clockwise to reduce system pressure. Set screw must be locked in place with the jam nut when adjustments are done.

5.0 TROUBLE SHOOTING

1. System will not build pressure. Check relief valve in the control valve or in the pump, for proper setting (see pump repair sheet or valve repair sheet). Check and secure all hose connections. If trouble is not corrected, remove cylinder and hoses from the valve. Now place a pressure gauge in port A and close (CW) the valve. If pressure cannot be developed, the unit should be taken to the nearest authorized ENERPAC Service Center. If pressure develops, the cylinder, hoses or couplers are the problem.
2. The cylinder will not build pressure. This is an indication of a worn valve seat which must be replaced by a Service Center.
3. VM22 has a check valve in-line with the pressure port. This check will hold the pressure at port A after the pump is turned off. When the pump is functioning properly, the valve closed, you can jog the pump and hold the pressure at port A.

6.0 MAINTENANCE

1. Periodically check all hydraulic connections to be sure they are tight. Loose or leaking connections may cause erratic and/or total loss of operation. Replace or repair all defective parts promptly.
2. Periodically check the hydraulic oil level in your system.
3. Change hydraulic oil approximately every 250-300 hours of operation. In dusty or dirty areas, it may be necessary to change the oil more frequently.

7.0 STORAGE INSTRUCTIONS

In the event that the unit would be stored for any great length of time (30 days or more), prepare as follows:

1. Wipe the entire unit clean.
2. Disconnect all hydraulic lines to prevent accidental operation.
3. Cover the unit with some type of protective cover.
4. Store in a clean, dry environment that is NOT exposed to extreme temperatures.

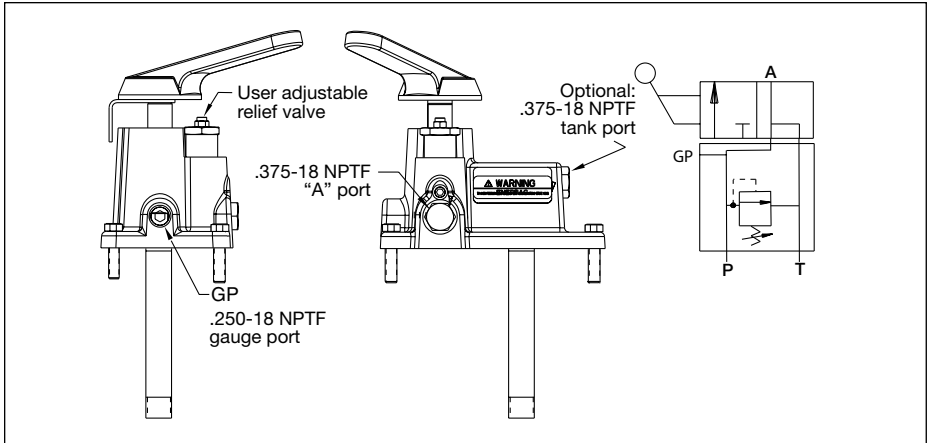

Figure 1, VM32, Pump Mounted

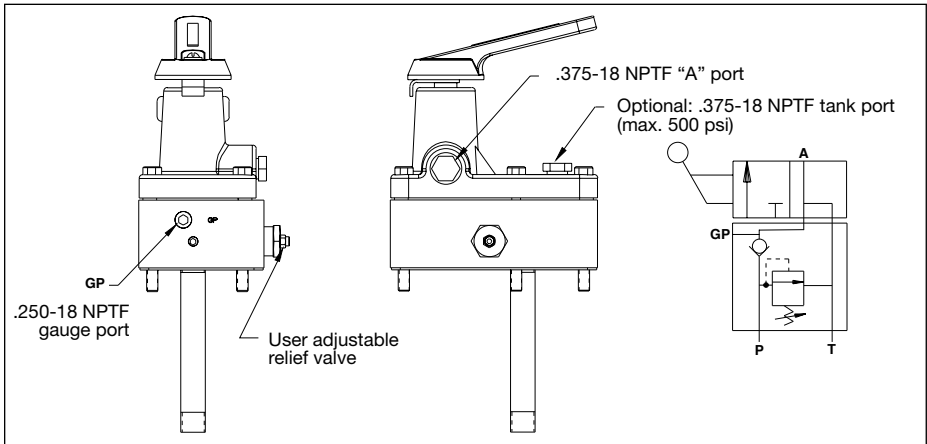

Figure 2, VM22, Pump Mounted

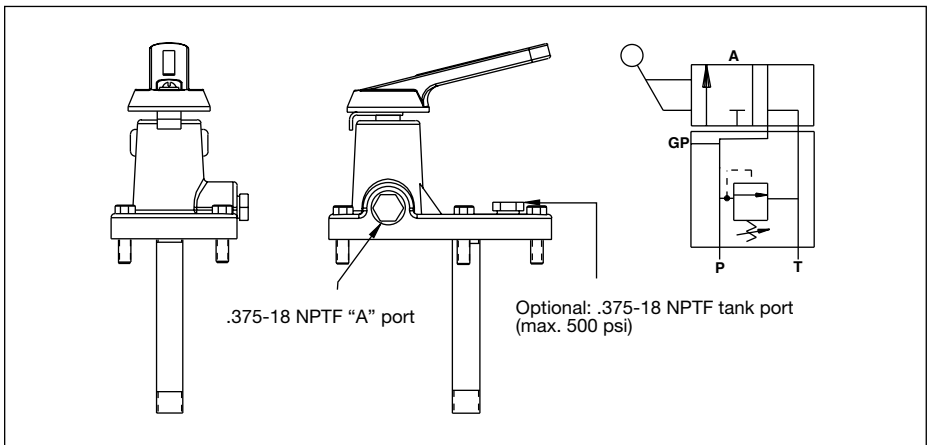

Figure 3, VM2, Pump Mounted