

# ZU Series Specifications and Dimensions

ZU4 Performance							
Motor Size (hp)	Output Flow Rate (in <sup>3</sup> /min)				Motor Electrical Specification (volts-ph-Hz)	Sound Level (dBA)	Relief Valve Adjustment Range (psi)
	100 psi	700 psi	5000 psi	10,000 psi			
1.7	700	535	76	60	115-1-50/60 230-1-50/60	85-90	2,000-10,000

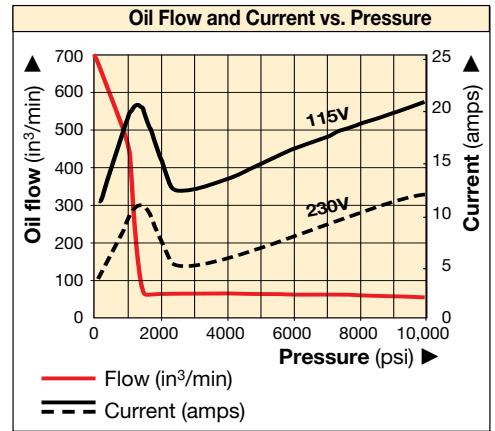

## ZU4 Series with 1.2 and 1.8 gallon reservoirs

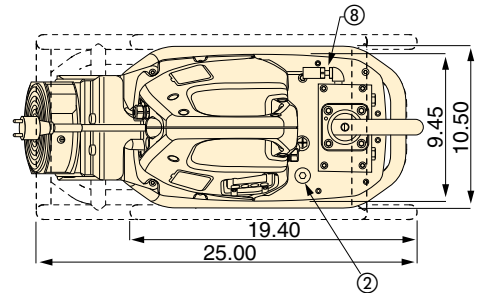
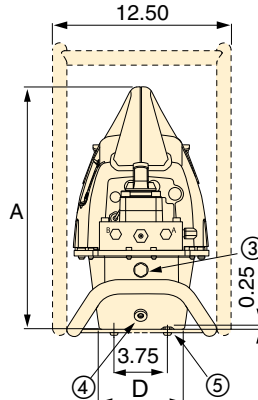
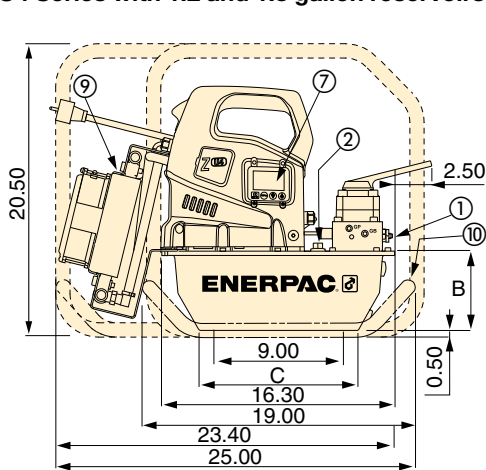

## ZU-4 Series with 5.2 and 10.3 gallon reservoirs (Left view shown without side handle)

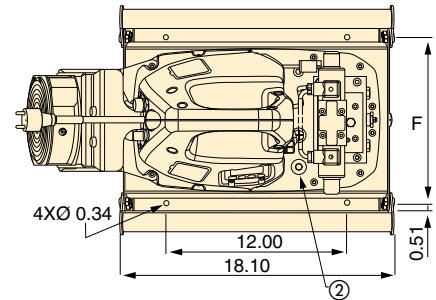
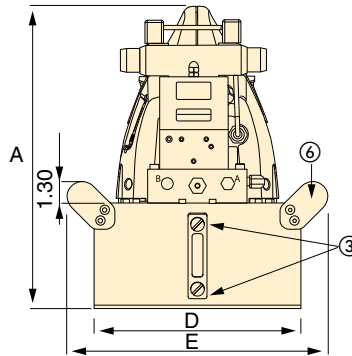
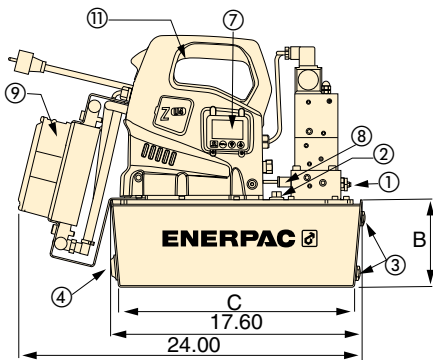

- ① User adjustable relief valve
- ② Oil fill port, SAE#10
- ③ Oil level sight gauge
- ④ Oil Drain, 1/2" NPTF
- ⑤ M8 x 1.25
- ⑥ Handles on all 5.2 and 10.3 gallon reservoirs
- ⑦ Back-lit LCD Electric
- ⑧ Pressure transducer
- ⑨ Heat exchanger
- ⑩ Skid bar
- ⑪ Handle guard installed on all 5.2 and 10.3 gallon reservoirs
- ⑫ Reservoir handles (not shown) included on all 5.2 and 10.3 gallon pumps



◀ Increased output flow and extended brush life increase productivity for post-tensioning applications.

Reservoir Capacity (gal)	Pump Dimensions (in)					
	A	B	C	D	E	F
1.2	16.7	5.6	11.0	6.0	-	-
1.8	16.7	5.6	11.0	8.1	-	-
5.2	18.3	7.1	16.5	16.6	19.7	15.6
10.3	21.7	10.6	15.7	19.9	22.7	18.9