



Instruction Sheet

ZUTP1500-S Series
Electric Tensioning Pumps
21,750 psi [1500 bar]

L4279

Rev. D

08/20

EN

To protect your warranty, use only ENERPAC hydraulic oil.

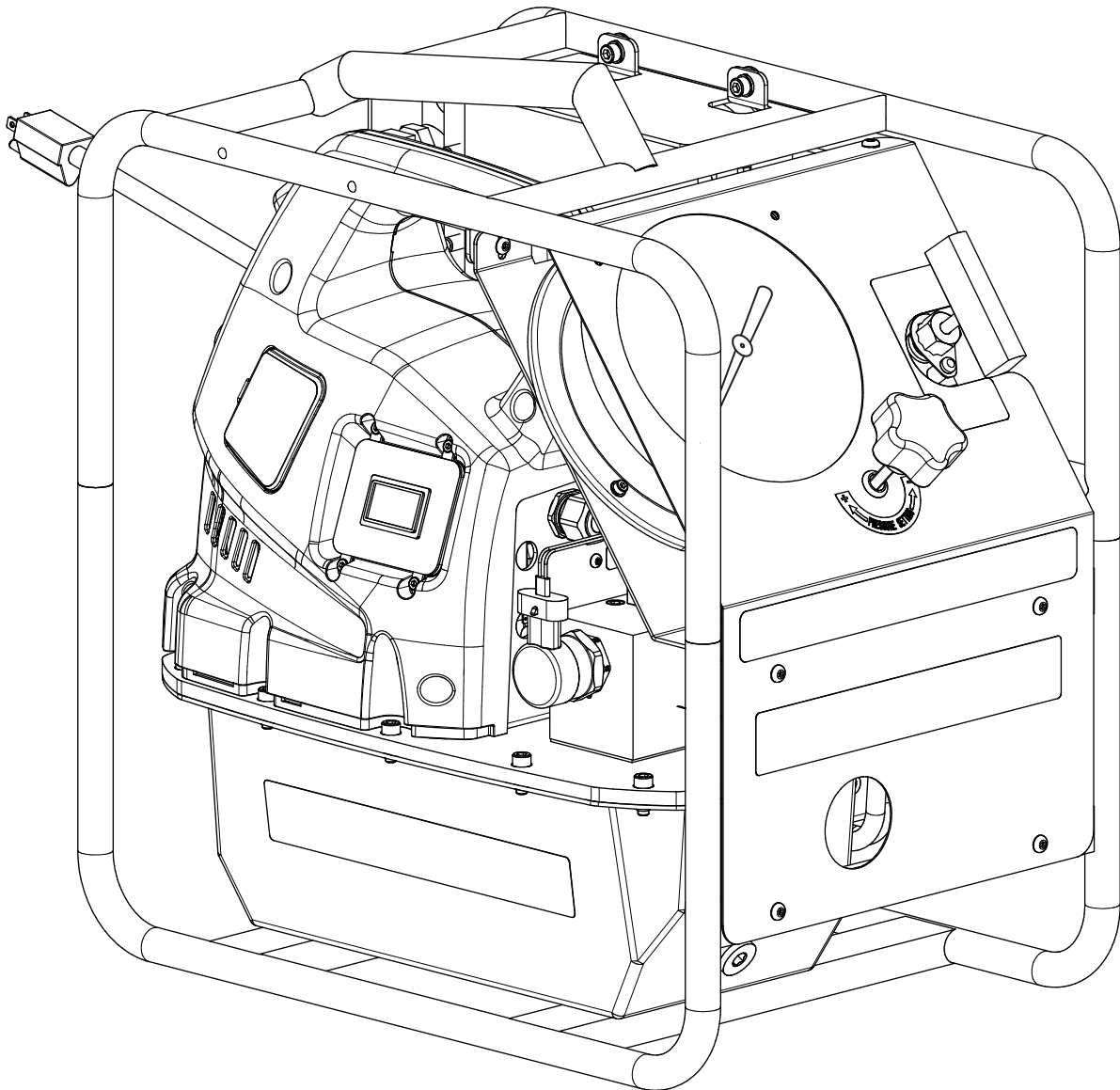

Table of Contents:

1.0 RECEIVING INSTRUCTIONS.....	3	7.0 HYDRAULIC CONNECTIONS	9
2.0 IMPORTANT SAFETY INSTRUCTIONS	3	8.0 POWER REQUIREMENTS.....	9
2.1 Introduction.....	3	9.0 OPERATION.....	9
2.2 General Hydraulic Safety Precautions..	3	9.1 Pendant Controls.....	9
2.3 Hydraulic Tensioning Safety	4	9.2 Depressurizing the System.....	10
2.4 Electrical Safety.....	4	9.3 Setting the Pump Pressure Relief Valve	10
2.4.1 Electrical Safety Precautions	4	9.4 Transporting the Pump.....	11
2.4.2 Use and Care.....	4	9.5 Pump Location.....	11
2.4.3 Disconnecting Power	4	9.6 Preparation for Use	11
2.4.4 Grounding Instructions	5	9.7 Operating Precautions	11
2.4.5 Use Of Extension Cords.....	5	9.8 Operation.....	11
2.5 Additional Precautions.....	5	9.9 Hourmeter	11
3.0 MAJOR FEATURES AND COMPONENTS.....	6	9.10 Circuit Breaker.....	11
4.0 PRODUCT DATA.....	7	10.0 MAINTENANCE.....	12
4.1 External Dimensions	7	10.1 Hydraulic Oil Information	12
4.2 Specifications	7	10.2 Checking Oil Level.....	12
4.3 Recommended Enerpac Ultra High Pressure Hoses and Hydraulic Components (sold separately)	7	10.3 Adding Oil.....	12
4.4 Pressure, Flow and Current Draw.....	8	10.4 Oil Change.....	12
5.0 PRODUCT DESCRIPTION.....	8	10.5 Heat Exchanger Maintenance (pumps equipped with optional heat exchanger)	12
5.1 Introduction.....	8	10.6 Hydraulic Filter Element Cleaning and Replacement.....	13
5.2 Conformance to National & International Standards	8	11.0 TROUBLESHOOTING	14
5.3 Electromagnetic Compatibility (EMC) ..	8	Troubleshooting Guide.....	14
6.0 HYDRAULIC RESERVOIR BREATHER.....	8		

1.0 RECEIVING INSTRUCTIONS

Visually inspect all components for shipping damage. Shipping damage is not covered by warranty. If shipping damage is found, notify carrier at once. The carrier is responsible for all repair and replacement costs resulting from damage in shipment.

2.0 IMPORTANT SAFETY INSTRUCTIONS

2.1 Introduction

Read all instructions carefully. Follow all recommended safety precautions to avoid personal injury as well as damage to the pump and/or damage to other property. Enerpac cannot be responsible for any damage or injury from unsafe use, lack of maintenance or incorrect operation. Do not remove warning labels, tags, or decals. In the event any questions or concerns arise, contact Enerpac or a local Enerpac distributor for clarification.

SAVE THIS INSTRUCTION SHEET FOR FUTURE USE

If you have never been trained on high-pressure hydraulic safety, consult your distributor or service center for information about an Enerpac hydraulic safety course.

This manual follows a system of safety alert symbols, signal words and safety messages to warn the user of specific hazards. Failure to comply with these warnings could result in death or serious personal injury, as well as damage to the equipment or other property.



The **Safety Alert Symbol** appears throughout this manual. It is used to alert you to potential physical injury hazards. Pay close attention to Safety Alert Symbols and obey all safety messages that follow this symbol to avoid the possibility of death or serious personal injury.

Safety Alert Symbols are used in conjunction with certain Signal Words that call attention to safety messages or property damage messages and designate a degree or level of hazard seriousness. The Signal Words used in this manual are DANGER, WARNING, CAUTION and NOTICE.



Indicates a hazardous situation that, if not avoided, **will** result in death or serious personal injury.



Indicates a hazardous situation that, if not avoided, **could** result in death or serious personal injury.



Indicates a hazardous situation that, if not avoided, **could** result in minor or moderate personal injury.



Indicates information considered important, but not hazard related (e.g. messages relating to property damage). Please note that the Safety Alert Symbol will **not** be used with this signal word.

2.2 General Hydraulic Safety Precautions



Failure to observe and comply with the following precautions could result in death or serious personal injury. Property damage could also occur.

- Do not remove or disable the pressure relief valve.
- Never set the pressure relief valve to a higher pressure than the maximum rated pressure of the pump.
- Stay clear of items being tensioned. To avoid personal injury, keep hands and feet away from tensioner pinch point areas.
- Do not handle pressurized hoses. Escaping oil under pressure can penetrate the skin. If oil is injected under the skin, see a doctor immediately.
- Do not pressurize disconnected couplers. Install properly rated blanking couplers in any unused couplers.
- Do not exceed equipment ratings. Overloading may cause equipment failure, possibly result in death or serious personal injury.
- Do not adjust, bypass or tamper with safety relief valves.
- Wear personal protective equipment (P.P.E.) when operating hydraulic equipment. Always wear eye protection. Safety equipment such as dust mask, non-skid safety shoes, hard hat, or hearing protection used for appropriate conditions will reduce personal injuries.
- Immediately replace worn or damaged parts with genuine ENERPAC parts. Standard grade parts will break causing personal injury and property damage.



Failure to observe and comply with the following precautions could result in minor or moderate personal injury. Property damage could also occur.

- Do not use or repair damaged hydraulic hose. Avoid sharp bends and kinks when routing hydraulic hoses. Using a bent or kinked hose will cause severe back-pressure. Sharp bends and kinks will internally damage the hose, leading to premature hose failure.
- Do not drop heavy objects on hose. A sharp impact may cause internal damage to hose wire strands. Applying pressure to a damaged hose may cause it to rupture.
- Do not lift hydraulic equipment by the hoses or swivel couplers. Use the carrying handle or strap.
- Keep hydraulic equipment away from flames and heat. Excessive heat will soften packings and seals, resulting in fluid leaks. Heat also weakens hose materials and packings. For optimum performance, do not expose equipment to temperatures of 150°F [65°C] or higher.
- Protect all hydraulic equipment from weld spatter. Immediately replace worn or damaged parts with genuine Enerpac parts. Enerpac parts are designed to fit properly and to withstand high loads. Non-Enerpac parts may break or cause the pump to malfunction.

NOTICE Hydraulic equipment must only be serviced by a qualified hydraulic technician. For repair service, contact the Enerpac Authorized Service Center in your area.

2.3 Hydraulic Tensioning Safety



Failure to observe and comply with the following precautions could result in death or serious personal injury. Property damage could also occur.

- Never exceed the maximum working pressure of the hydraulic tensioner (21,750 psi or 1500 bar unless otherwise specified). Maximum working pressure is stamped on the tensioner body.
- Never stand in-line with the bolt axis while tensioning or detensioning is in progress. If the bolt should fail, serious personal injury or death could result if loose or broken parts become projectiles. All personnel must be aware of this potential hazard at all times. High pressure hydraulic equipment can be very dangerous if misused.
- Keep away from oil leakages at high pressure. Liquid escaping from highly pressurized equipment has sufficient power to penetrate the skin, which can cause blood poisoning. In the case of such an accident, seek IMMEDIATE medical attention.
- Do not exceed the maximum allowable piston movement (stroke) of the hydraulic tensioner. An indicator will appear when the tensioner is near maximum extension. Refer to the maximum stroke dimension stamped on the tensioner body.
- Never attempt to repair leaks while the system is pressurized. Be sure system pressure gauge indicates zero (0) psi/bar before making repairs.
- Check that the bolt material is capable of taking the initial load to be applied. Hydraulic tensioners are powerful tools and are capable of yielding or breaking studs/bolts if tensile/yield properties are not sufficient to support the load applied.
- Use caution when pressurizing a system. Pressure can rise faster than anticipated. Continuously monitor the pressure gauge during pressurization. Be prepared to stop the pump immediately at any time.
- Be sure that the relief valve is adjusted to the appropriate setting, so the hydraulic tensioners do not apply excessive force for the application. The hydraulic working pressure must not exceed 1500 bar [21,750 psi].
- Never leave a pressurized system unattended. If you must leave the area, stop the pump, fully open the pressure release valve and ensure that hydraulic pressure gauge indicates zero (0) psi/bar.
- Any maintenance or repairs to the hydraulic tensioner(s), the pump or related components must be performed with the equipment in the unpressurized state (0 psi/bar).
- Refer to the tensioner instruction manual for important operation, safety and maintenance information specific to the tensioner(s) being used. Read, understand and follow tension manufacturer's instructions and safety precautions.

2.4 Electrical Safety

2.4.1 Electrical Safety Precautions



Failure to observe the following instructions and precautions may result in serious personal injury or death.

- High voltage is present inside the pump even when motor is off. Before opening the pump housing or performing any maintenance or repairs, be sure that the pump power cord is disconnected from the electrical outlet or other electrical power source.

- Always be certain that the pump is stopped and disconnected from AC power supply before performing any inspection, maintenance or repair procedures.
- Do not leave the pump unattended in the workplace when connected to AC power supply. Take all reasonable precautions to avoid unauthorized use.
- Take precautions so that the pump is not switched on accidentally.
- If it is not possible to unplug the pump power cord from the AC power outlet, the power must be turned off and locked out at the AC power supply.
- Always disconnect the pump from AC power before transporting it.
- Do not use the pump if it cannot be switched on and off using the pendant. Pump must be repaired before use.
- Make sure the pump cooling vents and heat exchanger fan openings (units equipped with heat exchanger only) are unobstructed and free of dirt or dust.
- Do not service or clean the hydraulic tensioner(s) while the pump is operating and/or if pump is connected to AC power supply.
- Keep electric tools out of the reach of children. Do not allow inexperienced users or users who have not read the instructions to operate them.

2.4.2 Use and Care



Failure to observe and comply with the following precautions could result in death or serious personal injury. Property damage could also occur.

- Store the pump indoors. Keep in a secured area to prevent use by unauthorized personnel.
- Do not clean the pump with a water spray or the like.
- Do not operate the pump with a damaged cord or plug, or after the pump malfunctions or is dropped or damaged in any manner. Return the pump to the nearest Enerpac authorized service center for examination, repair, or electrical or mechanical adjustment.

2.4.3 Disconnecting Power



Failure to observe and comply with the following precautions could result in death or serious personal injury. Property damage could also occur.

- Be sure that the pump is off before removing plug from electrical outlet.
- Do not unplug the pump by pulling on the cord. To unplug, grasp the plug, not the cord.
- Remove plug from electrical outlet when the pump is not in use and before servicing or cleaning the pump.

2.4.4 Grounding Instructions



Failure to observe the following instructions and precautions may result in serious personal injury or death.

- The pump must be properly grounded. In the event of malfunction or breakdown, grounding provides a path of least resistance for electric current to reduce the risk of electric shock. The pump is equipped with a cord having an equipment grounding conductor.
- A grounding plug is included with the cord. The plug must be plugged into an appropriate outlet that is properly installed and grounded in accordance with all local codes and ordinances.
- Improper connection of the pump grounding conductor can result in electric shock. The conductor with insulation having an outer surface that is green with or without yellow stripes is the pump grounding conductor.
- If the cord and/or plug are damaged, do not connect the pump to a live electrical outlet. Repair or replace the damaged items as required and be sure the grounding conductor is properly wired before reconnecting the pump to the outlet. Consult a qualified electrician if grounding conductor wiring procedures are not completely understood or if there is any doubt as to whether the pump is properly grounded.
- Do not modify the plug provided with the pump. If the plug will not fit in the outlet, have a proper outlet installed by a qualified electrician.
- A qualified electrician should be consulted if there is any doubt as to whether an outlet box is properly grounded.
- This pump is equipped with an electric power cord and plug specific to its rated single-phase voltage. No adapter should be used with the plug
- If the pump must be reconnected for use on a different type of electric circuit, the reconnection should be made by a qualified electrician. After the reconnection, the pump should comply with all local codes and ordinances.

2.4.5 Use Of Extension Cords



Failure to observe the following instructions and precautions may result in serious personal injury or death.

- Use the proper size extension cord with the pump power cord when use of an extension cord is necessary. A qualified electrician should be consulted to help specify and select the proper size extension cord. The marked electrical rating of the extension cord should be at least as great as the electrical rating of the pump.
- The extension cord should be a grounding-type 3-wire cord for single-phase power.
- A long extension cord should be arranged so that it will not drape over any working area where it can be tripped over, snagged, or pulled on unintentionally.
- If the pump is to be operated outdoors and an extension cord is needed, use only an outdoor-use extension cord. An outdoor-use extension cord will be clearly marked with the suffix letter “W” and the statement “Suitable for Use with Outdoor Appliances.”

2.5 Additional Precautions

WARNING Do not use electric pumps in an explosive atmosphere. Sparks and electrical arcing could ignite combustible vapors or airborne dust.

WARNING Do not expose the pump to rain, water, or moisture. Though the pump can be operated outdoors, in case of rain, the pump needs to be taken indoors. Failure to observe this precaution could result in an electric shock. Death or serious personal injury could occur.



CAUTION The pump is designed for a 33% duty cycle (10 minutes ON, 20 minutes OFF). Please allow time for the pump to cool before continuing with cycles. Failure to observe this precaution may result in motor damage.

CAUTION To prevent damage to the pump electric motor, check power specifications on pump data plate. Use of incorrect outlet will damage the motor.

3.0 MAJOR FEATURES AND COMPONENTS

Key

1. Heat Exchanger (optional)
2. Power Cord
3. Pendant
4. Oil Outlet Coupler
5. Hydraulic Reservoir Breather
6. Pressure Gauge
7. Manual Pressure Release Valve
8. User Adjustable Relief Valve Knob
9. User Adjustable Relief Valve Locknut
10. Oil Level Sight Glass
11. Drain Plug
12. Manifold
13. Control Valve (solenoid operated)
14. Hydraulic Reservoir
15. Shroud Air Vents
16. Hourmeter
17. Carrying Handle

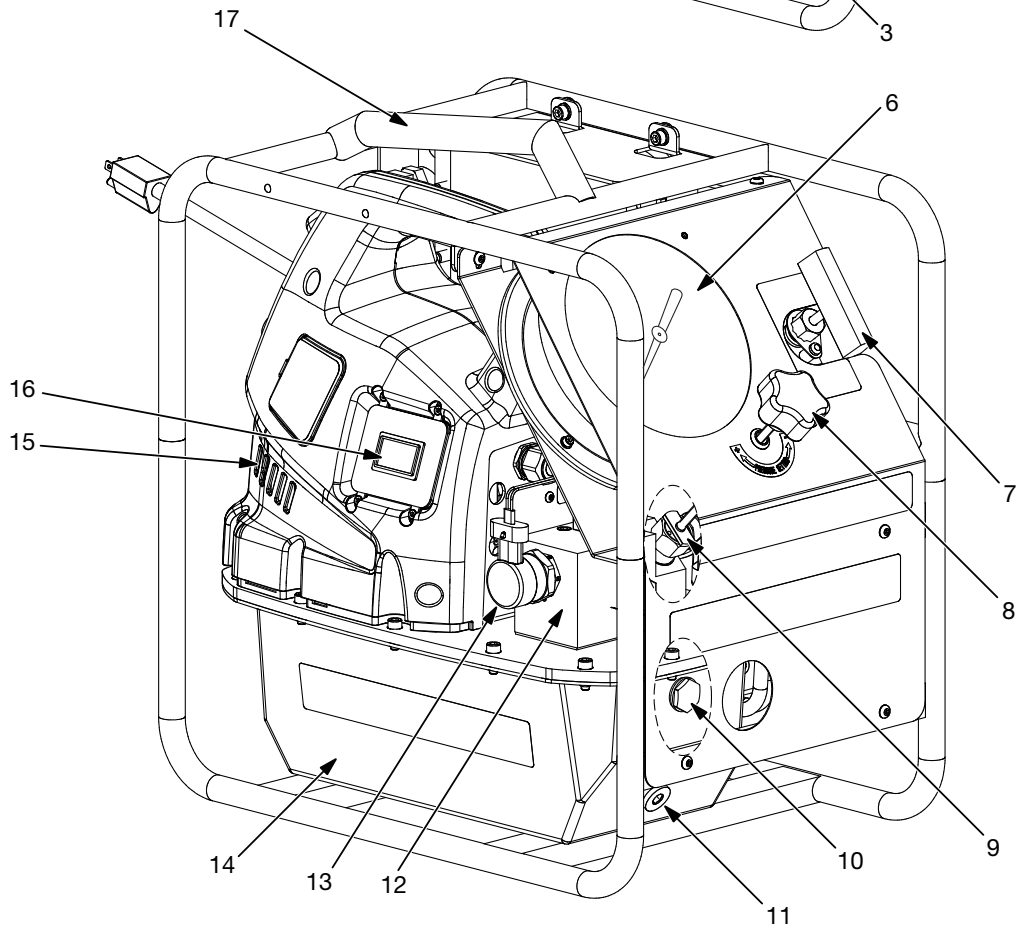
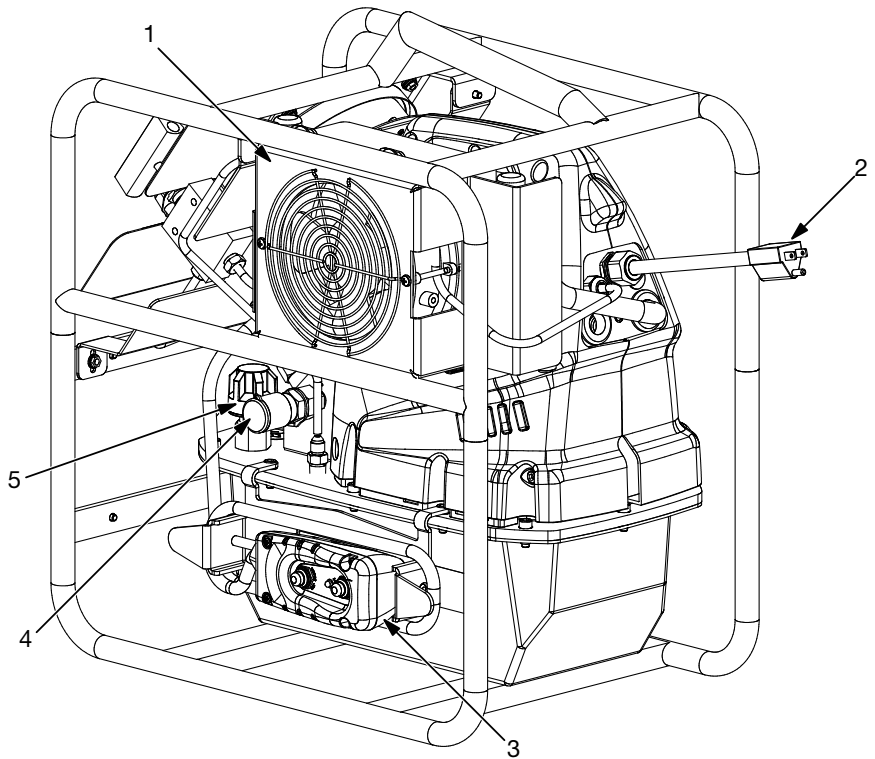

4.0 PRODUCT DATA

4.1 External Dimensions

Item	Dimension	
	inch	mm
A	19.00	483
B	18.75	476
C	20.64	524
D	12.75	324

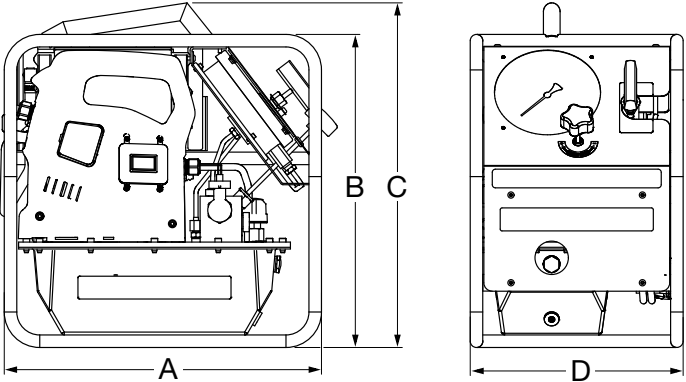

4.2 Specifications

Motor Size		Motor Duty Cycle	Output Flow Rate (approximate)				Sound Level	Usable Oil Capacity	
hp	kW		0 psi [0 bar]	10,000 psi [700 bar]	15,000 psi [1000 bar]	21,750 psi [1500 bar]	dBA	gallons	liters
1.7	1.25	33% (10 min. ON, 20 min. OFF)	230 in ³ /min [3.80 l/min]	32 in ³ /min [0.52 l/min]	27 in ³ /min [0.44 l/min]	20 in ³ /min [0.33 l/min]	89	1	3.8

NOTICE Output flow rates shown are based on 60 Hz operation. Flow rates at 50 Hz will be approximately 5/6 of these values

Pump Model Number	Rated Voltage	Plug Type	Heat Exchanger	Weight with Oil (approximate)	
				lbs	kg
ZUTP1500SB	115 VAC, 1-ph	NEMA 5-15	No	65	29.5
ZUTP1500SB-H	115 VAC, 1-ph	NEMA 5-15	Yes	75	34.0
ZUTP1500SI	230 VAC, 1-ph	NEMA 6-15	No	65	29.5
ZUTP1500SI-H	230 VAC, 1-ph	NEMA 6-15	Yes	75	34.0
ZUTP1500SE	230 VAC, 1-ph	Schuko	No	65	29.5
ZUTP1500SE-H	230 VAC, 1-ph	Schuko	Yes	75	34.0

Temperature Range	Hydraulic Oil Type	Seal Materials	Max. Hydraulic Working Pressure	Electric Current Draw
-20°F to 140°F [-29°F to 50°C]	Enerpac HF (ISO 32) or ISO 64 Synthetic	Buna, Viton and Polyurethane	21,750 psi [1500 bar]	(Refer to graphs in Section 4.4)

4.3 Recommended Enerpac Ultra High Pressure Hoses and Hydraulic Components (sold separately)

Description	Model Number	Length		Connections	
		ft	m	End 1	End 2
Hydraulic Tensioner Hose	HT1503	3.28	1.00	G ¼ 120° Cone	G ¼ 120° Cone
Hydraulic Tensioner Hose	HT1510	9.84	3.00	G ¼ 120° Cone	G ¼ 120° Cone
Hydraulic Tensioner Hose	* HT1503HR	3.28	1.00	BH150 Coupler	BR150 Coupler
Hydraulic Tensioner Hose	* HT1510HR	9.84	3.00	BH150 Coupler	BR150 Coupler

Description	Model Number		
	Complete Set	Female Half	Male Half
Quick Disconnect Coupler	* B150	* BR150	* BH150
Quick Disconnect Coupler And Adaptor Kit	* BW150AW	---	---
Quick Disconnect Blanking Coupler Set	* B150B	---	---

* Includes dust caps.

NOTICE Model numbers of ultra high pressure hydraulic hoses and components are subject to change without notice. Refer to Enerpac catalog for latest information and additional product details.

4.4 Pressure, Flow and Current Draw

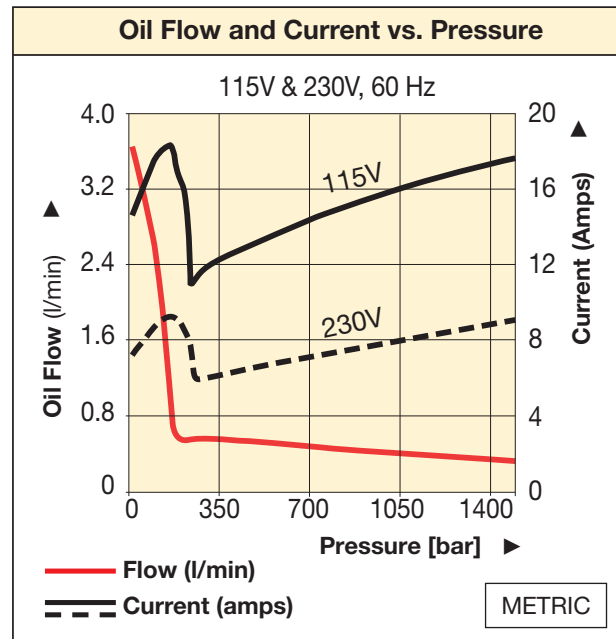
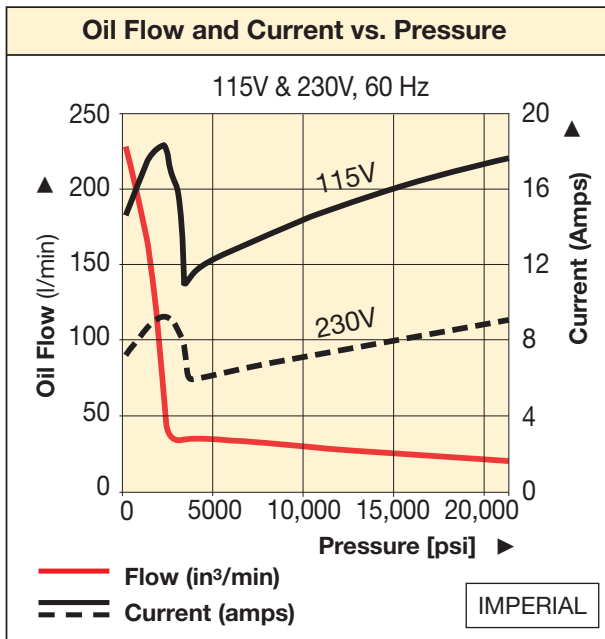

NOTE: Output flow rates shown are for 60 Hz operation. Flow rates at 50 Hz will be approximately 5/6 of these values.

5.0 PRODUCT DESCRIPTION

5.1 Introduction

The ZUTP1500-S Series electric tensioning pumps are designed to operate ultra high pressure hydraulic tensioners rated at 21,750 psi [1500 bar] working pressure.

A 20 foot [6 m] pendant and electric solenoid valve are included on all pump models, allowing the operator to easily pressurize and depressurize the system as required.

Major features include:

- 1.7 hp [1.25 kW] heavy-duty universal motor.
- Remote control 2 button pendant.
- Electric solenoid operated control valve.
- Manual pressure release valve.
- Replaceable 10 micron oil filter.
- Two-stage pump design for fast system fills and controlled flow at high pressures.
- Panel mounted 6" [152 mm] pressure gauge.

5.2 Conformance to National & International Standards

Energac declares that the ZUTP1500-S Series pumps have been tested and conform to applicable standards and are approved to carry the CE, TÜV C and US, and FCC certification marks. An EU declaration of conformity is enclosed separately.

5.3 Electromagnetic Compatibility (EMC)

The ZUTP1500-S Series pumps have been tested and certified to conform to CE-EMC Emission and Immunity standards and to FCC Emission standards.

6.0 HYDRAULIC RESERVOIR BREATHER

A shipping plug is installed in the breather port on the top of the reservoir. Before using the pump, remove the shipping plug and install the adapter fitting and breather. These parts are included loose in the shipment. Refer to Figure 1.

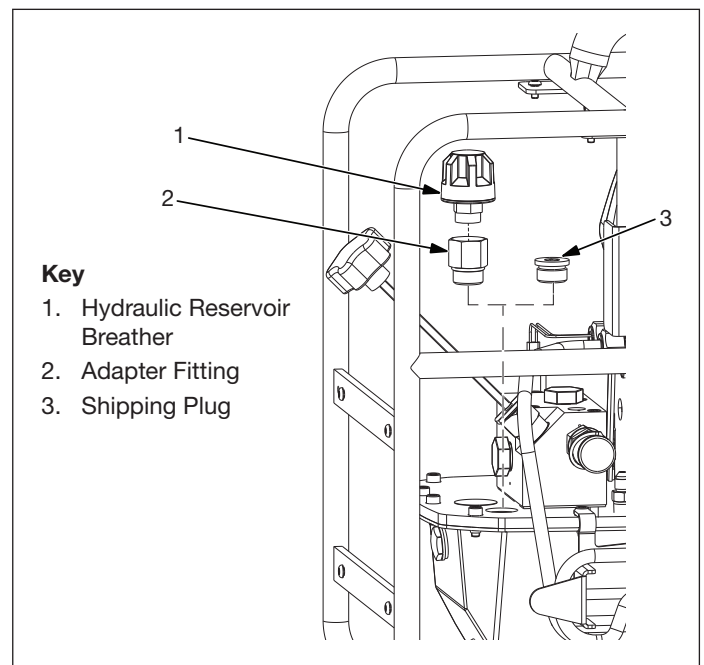

Figure 1, Hydraulic Reservoir Breather

7.0 HYDRAULIC CONNECTIONS

WARNING

Failure to observe and comply with the follow precautions could result in death or serious personal injury. Property damage could also occur.

- To prevent accidental startup of the pump, be certain that the pump is disconnected from electrical power before connecting or disconnecting hydraulic hoses.
- The ZUTP1500-S Series pumps must be operated only with hydraulic hoses and fittings rated to operate at 21,750 psi [1500 bar] working pressure. Hoses and fittings of a lower pressure rating will rupture or burst.

NOTICE Enerpac recommends the use of Enerpac HT1500 Series thermoplastic hoses with the ZUTP1500-S Series pumps. These hoses are rated at 21,750 psi [1500 bar]. Refer to Section 4.3 and the Enerpac catalog for additional information.

The ZUTP1500-S Series pumps are equipped with a female quick-disconnect hydraulic coupler for the oil outlet. This coupler is rated at 21,750 psi [1500 bar]. Refer to Figure 2.

Before connecting a hose to the oil outlet coupler, verify that the pressure gauge indicates zero (0) psi/bar. Be certain that all hydraulic pressure is fully relieved before continuing. If any pressure remains, then relieve pressure as described in Section 9.2.

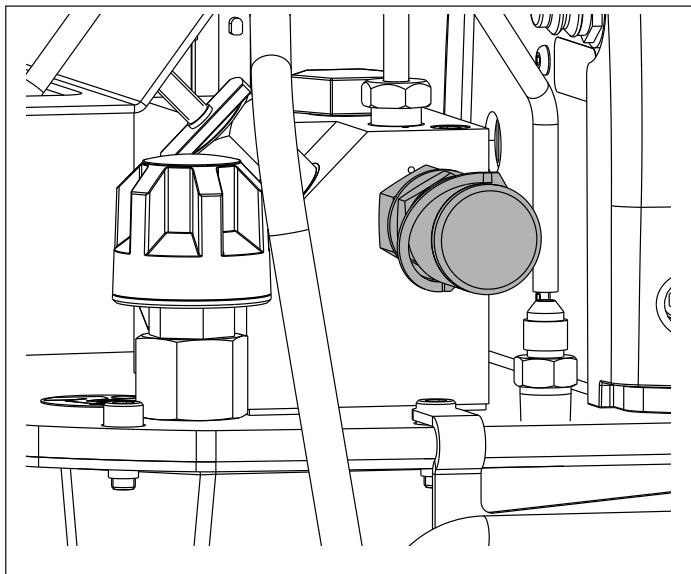

Figure 2, Oil Outlet Coupler

8.0 POWER REQUIREMENTS

The ZUTP1500-S Series pumps are available in three different versions to suit different electrical power requirements:

- Models ZUTP1500SB and ZUTP1500SB-H are designed for 115 VAC, single-phase, 50-60 Hz power. These models have a USA style NEMA 5-15 power plug.
- Models ZUTP1500SI and ZUTP1500SI-H are designed for 230 VAC, single-phase 50-60 Hz power. These models have a NEMA 6-15 power plug.
- Models ZUTP1500SE and ZUTP1500SE-H are designed for 230 VAC, single-phase 50-60 Hz power. These models have a European style “Schuko” power plug.

Before connecting electrical power to the pump, be certain that the power supply is the proper voltage and Hz for the pump version that you are using. Refer to the pump data plate. Also refer to Section 2.4 for important electrical safety information and precautions.

WARNING

Failure to follow the electrical safety precautions contained in Section 2.4 of this manual could result in electric shock. Death or serious personal injury could occur.

9.0 OPERATION

9.1 Pendant Controls

Refer to Figure 3.

NOTICE The user adjustable pressure relief valve setting must be set high enough for pressure to build when the motor is started. Refer to Section 9.3 for user adjustable pressure relief valve setting instructions.

- The motor jog button starts and stops the motor. When the motor jog button is pressed the motor starts. This builds system pressure and the hydraulic tensioner(s) is actuated for as long as the button is depressed. Releasing the button will stop the motor, but a check valve will hold system pressure.
- When the pressure dump button is pressed, system pressure is relieved and flow is directed to the reservoir. Flow will continue to be directed to the reservoir until the motor jog button is pressed.
- The active indicator light will illuminate when the motor jog button is pressed. It will remain illuminated until the pressure dump button is pressed or the power cord is disconnected.

CAUTION

The pump is designed for a 33% duty cycle (10 minutes ON, 20 minutes OFF). Please allow time for the pump to cool before continuing with cycles. Failure to observe this precaution may result in motor damage.

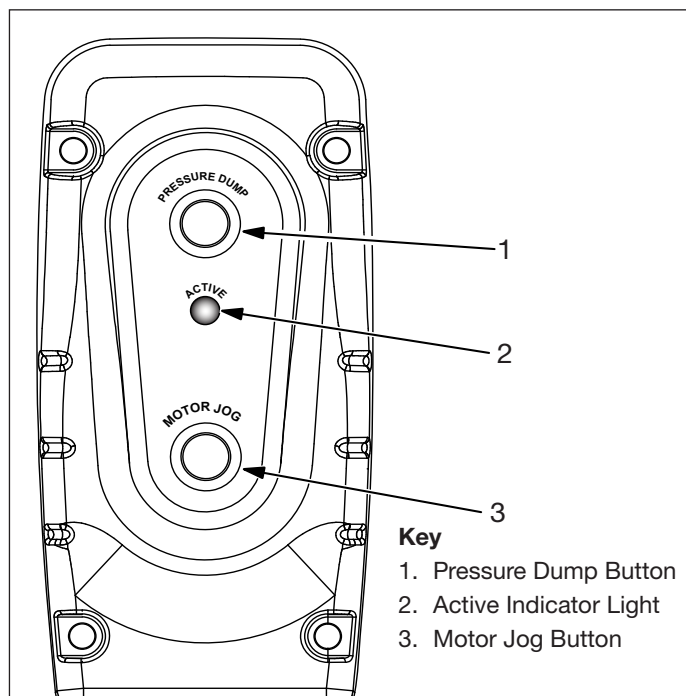

Figure 3, Pendant

9.2 Depressurizing the System

To relieve system pressure:

1. If not already connected, connect the pump to an electrical power source.
2. Press the pressure dump button. Refer to Figure 3.
3. Check that the pressure gauge indicates zero (0) psi/bar.

If electrical power fails, or if the control valve solenoid or pendant malfunctions, system pressure may be trapped. To manually relieve pressure under these conditions:

1. Rotate the manual pressure release valve handle counterclockwise to the open position to release pressure. Refer to Figure 4.
2. Verify that the pressure gauge indicates zero (0) psi/bar.
3. Rotate the handle on the manual pressure release valve clockwise to the closed position to close the valve. Tighten until hand tight. To prevent damaging the valve, DO NOT use excessive force.

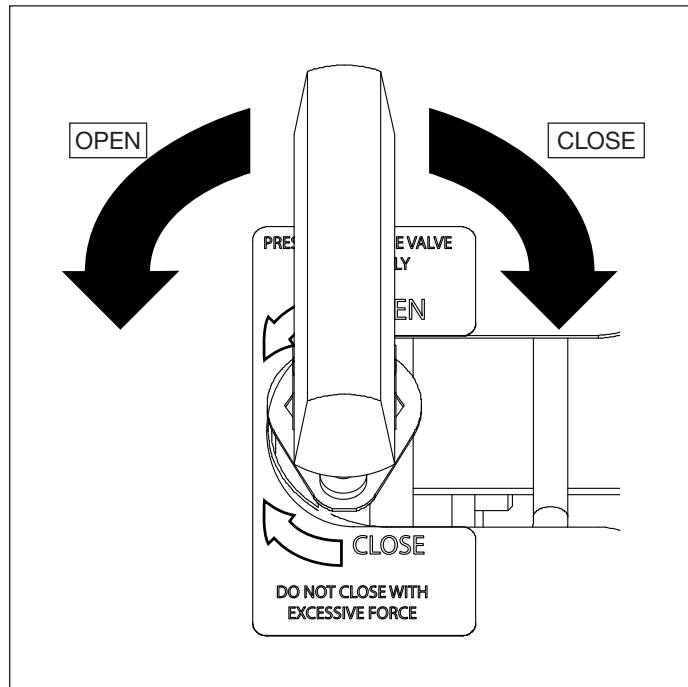

Figure 4, Manual Pressure Release Valve

9.3 Setting the Pump Pressure Relief Valve

NOTICE The relief valve pressure setting must be adjusted before the pump is placed into operation.

Set the pump pressure relief valve as described in the following steps:

1. Verify that the pressure gauge indicates zero (0) psi/bar. Be certain that all hydraulic pressure is fully relieved before continuing this procedure. If any pressure remains, then relieve pressure as described in Section 9.2.
2. Disconnect hose (if connected) from the oil outlet coupler. Refer to Figure 2.
3. Install a male blanking coupler in the oil outlet coupler.

WARNING Use of a compatible male blanking coupler rated at 21,750 psi [1500 bar] is mandatory. Refer to Section 4.3 of this manual for blanking coupler set information. Use of an incompatible blanking coupler may result in high pressure oil leakage and/or catastrophic failure (projectile hazard). Death or serious personal injury could result.

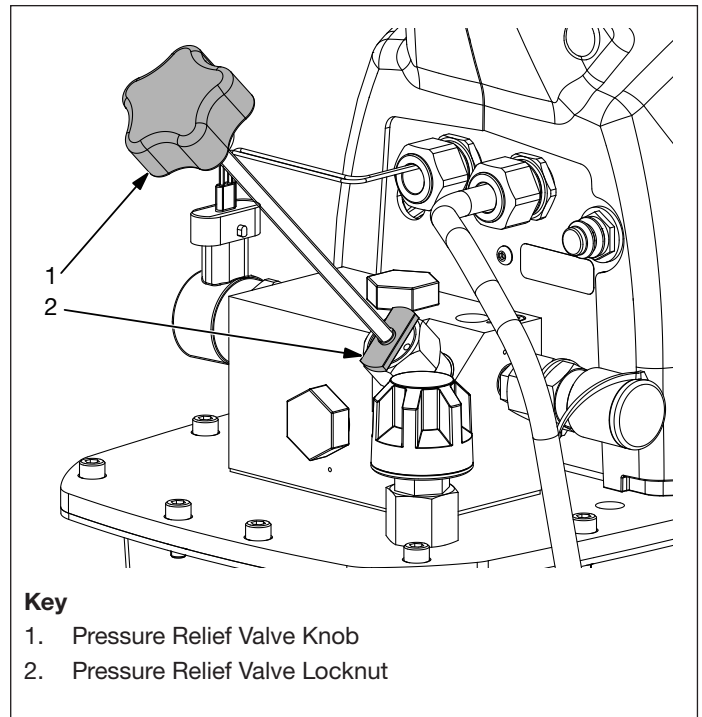

Figure 5, Pressure Relief Valve (user adjustable)

4. Loosen the pressure relief valve locknut to allow for pressure adjustment. Refer to Figure 5.
5. Turn the pressure relief valve knob several turns counterclockwise so that the relief valve is set lower than the desired setting. Refer to Figure 5.

NOTICE When adjusting the relief valve pressure, always start at a low setting. Then slowly increase the pressure to the desired setting.

6. Press and hold the motor jog button. The pump motor will start and pressure will begin building immediately.

WARNING

Pump maximum working pressure is 21,750 psi [1500 bar]. Do not set the relief valve pressure above 21,750 psi [1500 bar]. Failure to observe and comply with this instruction, may result in excessive hydraulic working pressures. High pressure oil leakage and/or component failures may occur. Death or serious personal injury could result.

7. While continuing to press and hold the motor jog button, slowly turn the user adjustable pressure relief valve knob clockwise (as required) until the desired pressure reading is shown on the pressure gauge.
8. When the desired reading is shown on the pressure gauge, release the motor jog button. The pump motor will stop.
9. After verifying that the pressure setting is correct, push the dump pressure button, to relieve pressure. Verify that the pressure gauge indicates zero (0) psi/bar.

WARNING

The pump contains an internal safety relief valve that is factory set to approximately 22,550 psi [1554 bar].

The safety relief valve is NOT user-adjustable. Never tamper with or attempt to readjust or disable the safety relief valve.

The safety relief valve should be serviced and adjusted only by an Enerpac Authorized Service Center.

9.4 Transporting the Pump

Always transport the pump using the handle at the top of the roll cage.

To prevent possible damage, never attempt to transport or reposition the pump by dragging it by the hose, power cord or pendant.

9.5 Pump Location

Place the pump in a location where airflow around the pump shroud vents are free and unobstructed.

On pumps equipped with the optional heat exchanger, be sure that the fan vents are not blocked by walls or other objects.

9.6 Preparation for Use

Before use, set the pump pressure relief valve and connect the hydraulic tensioner(s) and hose(s) as described in the following steps:

1. Set the pump pressure relief valve to the desired setting. Refer to Section 9.3.
2. After setting the pressure relief valve, press the pressure dump button to relieve any trapped pressure in the pump element and manifold. Refer to Section 9.2.
3. Release the pressure dump button. Check that the pressure gauge indicates zero (0) psi/bar. Be sure there is no pressure shown.
4. Connect hydraulic tensioner(s) and hose(s). Refer to the tensioner manufacturer's instructions for detailed tensioner setup and installation instructions. Also refer to instructions and precautions in Section 7.0 of this manual.

9.7 Operating Precautions



Failure to observe and comply with the following instructions and precautions could result in catastrophic tensioner failure and/or high pressure oil leakage. Death or serious personal injury could occur.

- Do not continue pressurizing hydraulic tensioner(s) after they reach maximum stroke length or operating pressure.
- Before pressurizing the system, read and understand all instructions and safety precautions applicable to the hydraulic tensioner(s) being used. Refer to the tensioner manufacturer's instructions for detailed tensioner operation and safety information.
- Follow safe work practices in accordance with all applicable laws, regulations and industry standards.
- Continuously monitor the pressure gauge while the pump is running.
- Stop the pump immediately if the tensioner maximum stroke length is reached or if oil leakage occurs. Pressures can rise faster than anticipated.

9.8 Operation

Operate the pump as described in the following steps. Refer to Figure 3 for a diagram of the pendant controls.

1. Press and hold the motor jog button to start the pump motor. The active indicator light will illuminate and pressure will begin building immediately. Continuously observe the pressure gauge while the pump is running.

NOTICE The amount of time required to pressurize a hydraulic circuit will vary depending on the quantity and type of hydraulic tensioner(s) connected, hydraulic hose lengths and other factors.

2. When the desired operating pressure is reached, release the motor jog button. The pump will stop and the active indicator light will remain lit.
3. Press the pressure dump button to relieve pressure. The active indicator light will turn off. The pressure gauge should indicate zero (0) psi/bar.

NOTICE For some systems, it may be necessary to manually retract the tensioner(s) after the hydraulic pressure is relieved.

9.9 Hourmeter

The pump is equipped with a digital hourmeter that displays the motor's elapsed running time. It should be used as a guide to help determine when oil changes and other scheduled maintenance procedures should be performed. The hourmeter operates only when the motor is running. It is not resettable.

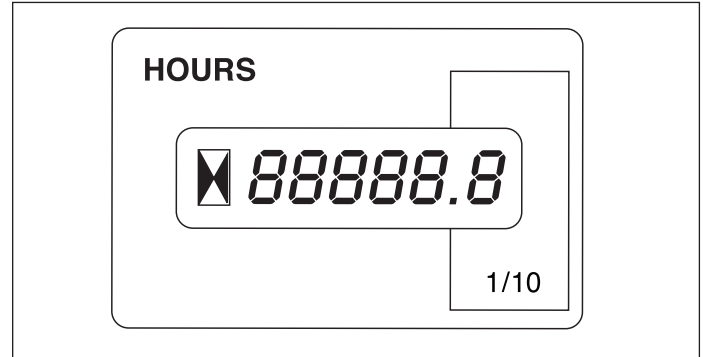

Figure 6, Hourmeter

9.10 Circuit Breaker

The pump circuit breaker is located at the front of the pump shroud. In the event of an electrical overload the circuit breaker will trip and the pump will stop. After investigating and correcting the source of the overload, push the circuit breaker button to reset. Refer to Figure 7.

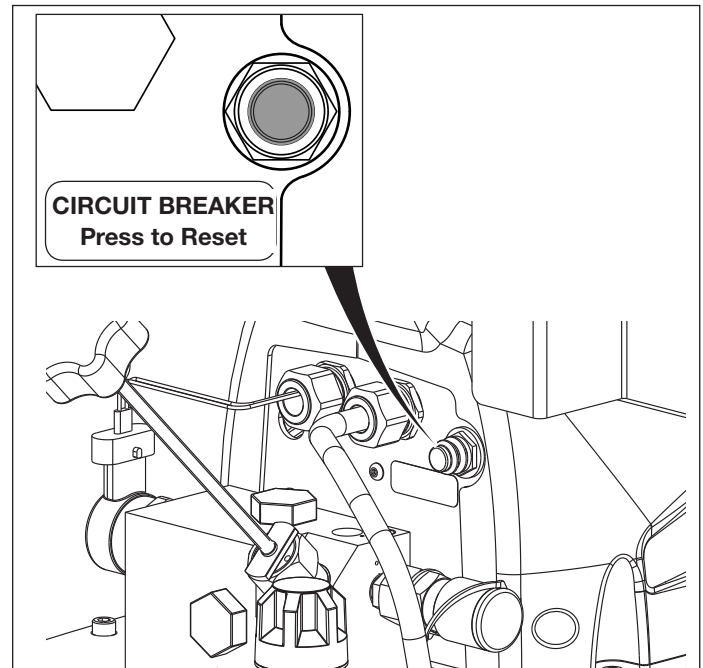

Figure 7, Circuit Breaker

10.0 MAINTENANCE



Failure to observe and comply with the following precautions could result in death or serious personal injury. Property damage could also occur.

- To avoid accidental starting, the pump must be disconnected from electrical power before maintenance is performed.
- Fully relieve all system pressure before performing any maintenance.

10.1 Hydraulic Oil Information

The pump reservoir is filled with Enerpac HF hydraulic oil (ISO Grade 32) prior to shipment. This oil is suitable for most applications and working environments.

For applications where unusually high ambient temperatures and/or extended duty cycles cause the oil temperature to exceed 130°F [54°C], the use of ISO Grade 64 synthetic hydraulic oil is recommended. This will help maintain maximum pump performance.

NOTICE Never mix oils of different viscosities. Mixing oil viscosities may result in damage to pump hydraulic components and will void the product warranty.

10.2 Checking Oil Level

1. Be sure hydraulic tensioner(s) is fully retracted.
2. Verify that the pressure gauge indicates zero (0) psi/bar. Be certain that all hydraulic pressure is fully relieved before continuing this procedure. If any pressure remains, then relieve pressure as described in Section 9.2.
3. Disconnect the power cord from the electrical outlet.
4. Be sure that the pump is placed on a level surface.
5. Visually check the oil level by looking through the oil level sight glass. Reservoir is FULL when oil level is about halfway between the top and bottom of the sight glass. Refer to Figure 8.

If oil level is low:

Add oil as described in Section 10.3. Refer to Section 10.1 for oil specifications.

NOTICE Be sure that the oil is clean. If the oil has a milky, cloudy or dark appearance, it should be changed immediately as described in Section 10.4.

10.3 Adding Oil

NOTICE Never mix oils of different viscosities. Mixing oil viscosities may result in damage to pump hydraulic components and will void the product warranty.

1. Be sure hydraulic tensioner(s) is fully retracted.
2. Verify that the pressure gauge indicates zero (0) psi/bar. Be certain that all hydraulic pressure is fully relieved before continuing this procedure. If any pressure remains, then relieve pressure as described in Section 9.2.
3. Disconnect the power cord from the electrical outlet.
4. Disconnect hydraulic hose from oil outlet coupler.
5. Remove hydraulic reservoir breather. Refer to Section 6.0.
6. Slowly pour new oil into the reservoir through the breather port. Refer to Section 10.1 for oil specifications. Refer to Section 10.2 for oil level check instructions.

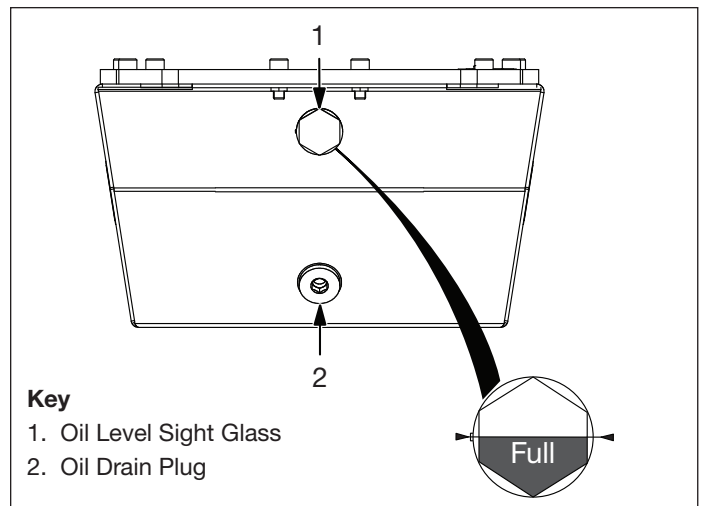

Figure 8, Sight Glass and Drain Plug

NOTICE Remove and dispose of any spilled oil in accordance with all applicable laws and regulations. Use only new oil poured from a clean container.

7. Reinstall hydraulic reservoir breather.

10.4 Oil Change

1. Be sure hydraulic tensioner(s) is fully retracted.
2. Verify that the pressure gauge indicates zero (0) psi/bar. Be certain that all hydraulic pressure is fully relieved before continuing this procedure. If any pressure remains, then relieve pressure as described in Section 9.2.

3. Disconnect the power cord from the electrical outlet.
4. Disconnect hydraulic hose from oil outlet coupler.

NOTICE The pump is equipped with a 1 gallon [3.8 liter] hydraulic reservoir. Be sure the pan or container is large enough to hold all the drained oil.

5. Place a suitable pan or container of appropriate capacity under the hydraulic reservoir drain plug. Refer to Figure 8.
6. Remove hydraulic reservoir drain plug.

NOTICE Remove and dispose of any used oil in accordance with all applicable laws and regulations.

7. Allow used oil to drain completely from the hydraulic reservoir.
8. Clean hydraulic reservoir drain plug and remove any metal shavings (plug is magnetic).
9. Reinstall hydraulic reservoir drain plug.
10. Clean or replace the hydraulic filter element. Refer to Section 10.6 for procedure.
11. Refill the reservoir with new hydraulic oil as described in Section 10.3

NOTICE It is recommended that the hydraulic reservoir breather be replaced at every oil change. Refer to Figure 1 for assembly details.

10.5 Heat Exchanger Maintenance (pumps equipped with optional heat exchanger)

- Check that the heat exchanger fan openings are unobstructed and free of dirt or dust.
- Check for loose or missing fasteners and components. Tighten or replace as required.
- Check the heat exchanger core and lines for oil leaks. If leaks are found, make repairs as required.
- Verify that heat exchanger fan starts when pump motor starts.

10.6 Hydraulic Filter Element Cleaning and Replacement

NOTICE To ensure optimal performance, always clean or replace the hydraulic filter element at every oil change.

To properly inspect, clean and replace the hydraulic filter, refer to the following steps:

1. Verify that the pressure gauge indicates zero (0) psi/bar. Be certain that all hydraulic pressure is fully relieved before continuing this procedure. If any pressure remains, then relieve pressure as described in Section 9.2.
2. Disconnect the power cord from the electrical outlet.
3. Loosen the user adjustable pressure relief valve locknut. Turn the relief valve knob counterclockwise until the shaft disengages from the threaded fitting on the valve manifold. Refer to Figure 5.
4. Remove the six M4 capscrews securing the front panel to the roll cage. Remove the front panel to provide access. Refer to Figure 9.

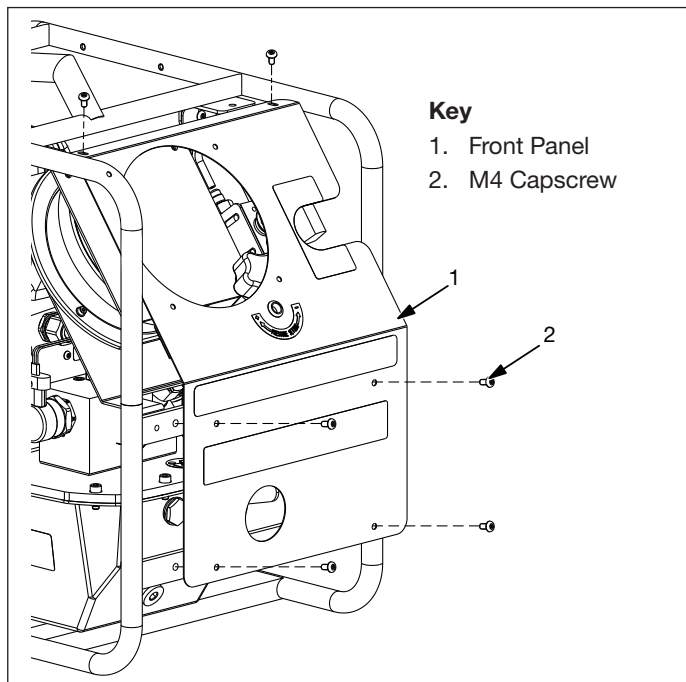

Figure 9, Front Access Panel



Be certain that hydraulic pressure is fully relieved before loosening the gland plug in the next step. Failure to observe this instruction may result in the uncontrolled release of pressurized hydraulic oil when gland plug is loosened. Skin penetration and serious personal injury may result.

5. Using a 1" wrench or socket, loosen and remove the gland plug from the valve manifold. Refer to Figure 10.

NOTICE After the gland plug is removed, the filter spacer, filter element and anti-extrusion disc can be removed with a pick or by carefully tipping the pump forward until the parts drop out.

6. Remove the filter spacer, filter element and anti-extrusion disc.
7. Remove any loose debris that may have accumulated on the filter spacer, filter element and anti-extrusion disc. Flush and clean the filter element.

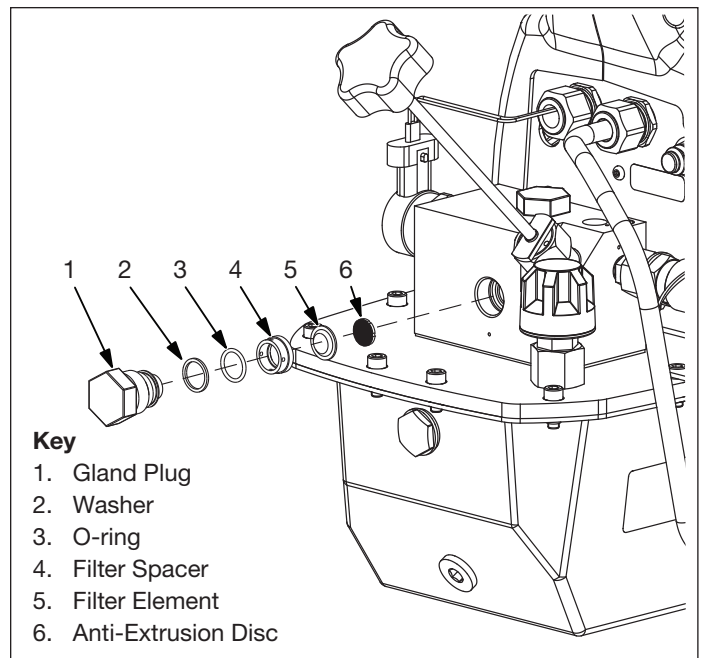

Figure 10, Filter Element

NOTICE The filter element should not be reused if it is very dirty. If embedded particles cannot be removed from the mesh by flushing, replace the old filter element with a new one. Refer to the pump repair parts sheet for replacement filter element part number.

8. Install the anti-extrusion disc. Be sure that the mesh side of the disc faces outward, toward the manifold opening.
9. Install the filter element. It can be installed with either side toward the manifold opening.
10. Install the filter spacer into the filter element.
11. Inspect the gland plug, O-ring and backup ring. Replace these parts if worn or damaged.
12. Thread the gland plug into the valve manifold using a 1" wrench or socket. Torque to 60-65 ft-lbs [81-88 Nm].
13. Reinstall the front panel on the roll cage with six M4 capscrews.
14. Thread the shaft of the user adjustable pressure relief valve knob into the threaded fitting on the valve manifold. After threads are engaged, rotate the user adjustable pressure relief valve knob clockwise several turns.
15. Readjust the relief pressure. Refer to Section 9.3.

11.0 TROUBLESHOOTING

The information in the Troubleshooting Guide is intended as an aid to help diagnose and correct various possible problems that may occur.

For repair service, contact your nearest Enerpac Authorized Service Center. Only an Enerpac Authorized Service Center should be permitted to service the pump and its components.



Failure to observe and comply with the following precautions could result in death or serious personal injury. Property damage could also occur.

- Never tighten or loosen hydraulic fittings while the pump hydraulic system or connected components are pressurized. Escaping oil under pressure can penetrate the skin, causing serious personal injury.
- Keep hands, fingers and other body parts clear of pinch points and moving parts when observing operation during troubleshooting.
- To prevent accidental start-up of pump during servicing, always disconnect the pump from electrical power sources before performing any maintenance or repair procedures.

Troubleshooting Guide			
Problem	Possible Cause	Action	
1. Pump will not start.	a. No power.	Be sure that the pump power plug is connected to AC power supply. Be sure that the voltage is correct for the pump model.	
	b. Pump circuit breaker tripped.	Push pump circuit breaker button to reset.	
	c. Low voltage.		Turn off other electric loads.
			Use heavier gauge extension cord.
	d. Motor brushes worn to end of life.	Contact Enerpac Authorized Service Center.	
2. Motor stops under load.	Low voltage.	Turn off other electric loads.	
		Use heavier gauge extension cord.	
3. Pump fails to build pressure or builds less than full pressure.	a. Pressure dump button is depressed.	Release pressure dump button.	
	b. Low oil in reservoir.	Add oil to reservoir. Refer to Section 10.3.	
	c. Manual pressure release valve is not fully closed (or cannot be fully closed due to internal wear).	Close valve hand tight. If wear is suspected, contact Enerpac Authorized Service Center.	
	d. Relief valve setting too low.	Adjust relief valve pressure. Refer to Section 9.3.	
	e. External system leak.	Repair or replace components as required.	
	f. Pump hydraulic filter element clogged.		Replace pump hydraulic filter element. Refer to Section 10.6.
			Change hydraulic oil. Refer to Section 10.4.
	g. Pump hydraulic oil intake screen is dirty.	Clean or replace hydraulic intake screen. Change hydraulic oil and filter element. Refer to Sections 10.4 and 10.6.	
	h. Internal leak in pump control valve.	Contact Enerpac Authorized Service Center.	
i. Internal leak in system component.	Contact Enerpac Authorized Service Center.		
4. Pump takes an excessively long time to build pressure.	a. Cold hydraulic oil.	Warm the hydraulic oil to approximately 60°F [15°C] by running the pump and allowing the oil to flow over the user-adjustable relief valve (set to 1000 psi [68 bar]).	
	b. Manual pressure release valve is not fully closed (or cannot be fully closed due to internal wear).	Close valve hand tight. If wear is suspected, contact Enerpac Authorized Service Center.	

(continued on next page)

Troubleshooting Guide (continued)		
Problem	Possible Cause	Action
4. Pump takes an excessively long time to build pressure. (continued)	c. Pump hydraulic filter element clogged.	Replace pump hydraulic filter element. Refer to Section 10.6. Change hydraulic oil. Refer to Section 10.4.
	d. Higher oil viscosity needed.	Change to ISO Grade 64 synthetic oil. Completely drain and refill reservoir per instructions in Section 10.4. NOTICE To prevent damage to pump, do not combine different oil grades.
	e. Install a heat exchanger.	Contact Enerpac Authorized Service Center.
5. Pump builds to full pressure, but hydraulic tensioner does not move.	a. Load greater than hydraulic tensioner capacity at full pressure.	Reduce load or increase hydraulic tensioner capacity.
	b. Flow to hydraulic tensioner is blocked.	Check hydraulic couplers for full engagement. Check hose for blockage or kinks.
6. Pressure is not relieved when pressure dump button is pressed.	a. Low voltage.	Check for proper voltage. Dump function may not operate if voltage is low.
	b. Pendant cable wires loose or broken.	Contact Enerpac Authorized Service Center. NOTICE If indicator light on valve solenoid illuminates when pressure dump button is pressed and released, pressure dump switch and pendant wiring are probably OK. Check for defective solenoid coil.
	c. Pump control valve needs cleaning or is not opening.	Contact Enerpac Authorized Service Center.
	d. Loose connections and/or damaged electrical components inside pump shroud.	Contact Enerpac Authorized Service Center.
7. Low oil flow.	a. Low oil level in hydraulic reservoir.	Check oil level and add oil to hydraulic reservoir if needed. Refer to Sections 10.2 and 10.3.
	b. Pump hydraulic filter element clogged.	Replace pump hydraulic filter element. Refer to Section 10.6. Change hydraulic oil. Refer to Section 10.4.
	c. Pump hydraulic intake screen dirty.	Clean or replace hydraulic intake screen. Change hydraulic oil. Refer to Section 10.4.
8. Hydraulic tensioner drifts back on its own when motor jog button is released.	a. External system leak.	Inspect all hydraulic connection. Tighten, repair or replace components as required.
	b. Pump check valve malfunctioning.	Contact Enerpac Authorized Service Center.
	c. Pump control valve needs repair.	Contact Enerpac Authorized Service Center.
9. Hydraulic tensioner will not return (or cannot be manually returned) when pressure is relieved.	a. Flow is restricted or blocked.	Check hydraulic couplers for full engagement. Check hose for blockage or kinks.
	b. Pump control valve malfunction.	Contact Enerpac Authorized Service Center.
10. Pump runs hot.	a. Flow restricted.	Check hydraulic couplers for full engagement. Check hose for blockage or kinks.
	b. Oil flowing over the relief valve for long periods of time.	Reduce the amount of motor running time while oil is flowing over the relief valve.
	c. Heat exchanger not working (pumps equipped with heat exchanger only).	Check for proper operation of heat exchanger. Repair or replace heat exchanger as required.

ENERPAC 
www.enerpac.com