

Pro L12000QNL/L12002QNL

Quick Reference

This *Quick Reference* card gives brief instructions on connecting your projector and using common features. For details, see the online *User's Guide*.

IMPORTANT: Before using this product, make sure you read these instructions and the safety instructions in the online *User's Guide*.

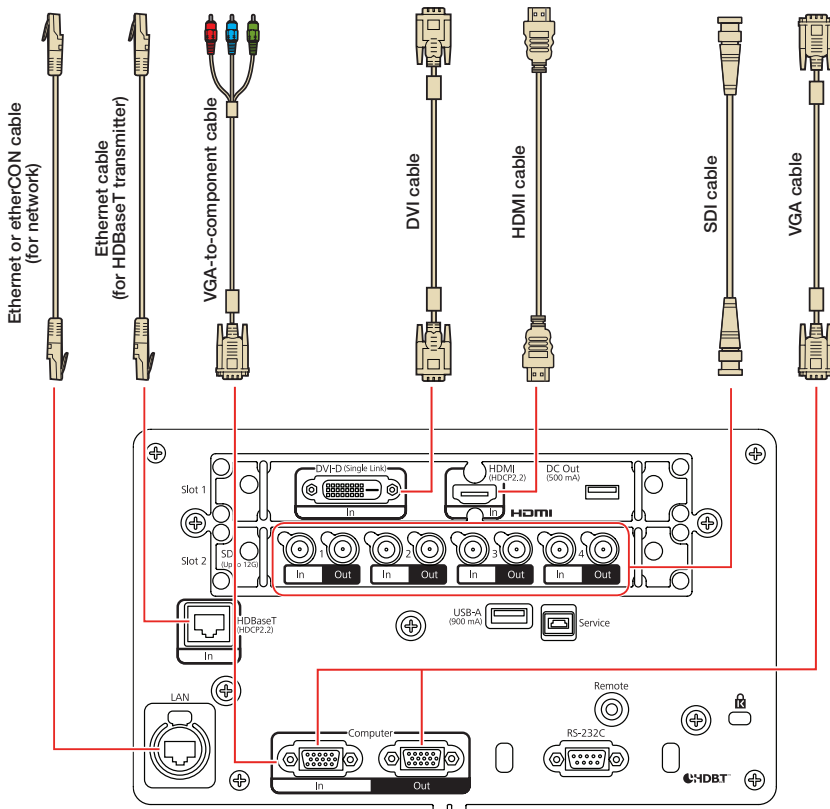

Turning the Projector On

1. Turn on your computer or image source.
2. Remove the lens cover.
3. Press the **⓪ On** button. After the Status light stays on, the projector is ready.

Note: If the Direct Power On function is enabled, you can turn the projector on without pressing the **⓪ On** button; just flip the switch controlling the outlet to which the projector is connected. To turn on this feature, see the online *User's Guide*.

If the projector does not turn on, make sure the power switch on the side of the projector is turned on.

If your image does not appear, see “Switching Between Image Sources” or “Troubleshooting.”

Changing the Language of the Projector Menu

The default language of the projector's menu system is English, but you can change it as necessary.

1. Press the **Menu** button to access the projector's menu system.
2. Select **Extended > Language**.
3. Select your language.
4. When you're done, press the **Menu** button to exit.

Changing the Projection Mode

You can change the projection mode to flip the image over top-to-bottom or left-to-right using the projector menus.

1. Press the **Menu** button.
2. Select **Extended > Projection**.
3. Select a projection mode.
4. When you're done, press the **Menu** button to exit.

You can also flip the image over top-to-bottom by pressing the **Shutter** button on the remote control for about five seconds.

Note: To rotate the menu display, change the **OSD Rotation** setting in the **Extended > Display** menu.

Switching Between Image Sources

Press the **Search** button (remote control) or one of the source buttons (remote control or projector).

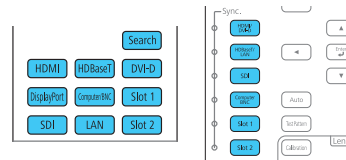

Changing the Screen Type Setting

Set the Screen Type setting to the screen's aspect ratio.

1. Press the **Menu** button.
2. Select **Extended > Display > Screen > Screen Type**.

3. Select the screen's aspect ratio.

Note: The displayed image should match the screen's size and shape.

4. When you're done, press the **Menu** button to exit.

Note: After changing the screen type, you may need to change the aspect ratio of the projected image depending on the input signal. Press the **Aspect** button on the remote control to change the aspect ratio, if necessary.

Adjusting Image Position

1. Press the **Lens Shift** button on the remote control or projector.



2. Press the arrow buttons to adjust the position of the projected image.
3. When you're done, press the **Esc** button to finish the adjustment.

If the projector is on a table, you can level the image by turning any of the projector's adjustable feet.

Focusing and Zooming

Press the **Focus** or **Zoom** buttons on the remote control to adjust the image.

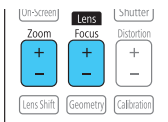

You can also focus and zoom using the projector buttons.

1. Press the **Focus** or **Zoom** button on the projector.

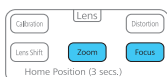

2. Press the ◀ or ▶ arrow buttons to make the adjustment.
3. Press the **Esc** button to finish the adjustment.

Note: Depending on the lens you use, you may need to adjust the Distortion setting after you adjust the Focus setting. See the online *User's Guide*.

Correcting Image Shape

If your image is uneven on the sides, you can use the projector's distortion correction features, such as H/V-Keystone and Quick Corner®, to adjust the shape. See the online *User's Guide*.

Making Other Image Adjustments

For help on using the projector's features to improve the image quality, see the online *User's Guide*. You can also view information on how to adjust the image color, position, and edges (Edge Blending) when projecting from multiple projectors to create one seamless widescreen image.

Turning the Projector Off

Press the ⏻ **Standby** button to turn the projector off. If you see a confirmation message, press the ⏻ **Standby** button again.

Note: You can also just flip the switch controlling the outlet to which the projector is connected instead.

Troubleshooting

If you see a blank screen or the message **No signal**

- Make sure the projector Status light is on and not flashing, and the lens cover is removed.
- Make sure the cables are connected correctly. See the online *User's Guide*.
- You may need to change the image source. See “Switching Between Image Sources.” Also make sure the source device is turned on.

If the projector and the notebook don't display the same image

Windows®

Press the function key on your keyboard that lets you display on an external monitor. It may be labeled **CRT/LCD** or have an icon such as . You may have to hold down the **Fn** key while pressing it (such as **Fn + F7**). Wait a moment for the display to appear. You may need to press the keys again to display the image on both devices.

On Windows 7 or later, hold down the Windows key and press **P** at the same time, then click **Duplicate**.

Mac

Open **System Preferences** and select **Displays**. Click the **Arrangement** tab and select the **Mirror Displays** checkbox.

Where to Get Help

Manuals

For more information about using the projector, you can view or download the online manuals from the Epson website, as described below.

Internet support

Visit www.epson.com/support (U.S.) or www.epson.ca/support (Canada) and search for your product to download software and utilities, view manuals, get FAQs and troubleshooting advice, or contact Epson.

Speak to a support representative

To use the Epson® PrivateLine® Support service, call (800) 637-7661. This service is available for the duration of your warranty period. You may also speak with a projector support specialist by dialing (562) 276-4394 (U.S.) or (905) 709-3839 (Canada).

Support hours are 6 AM to 8 PM, Pacific Time, Monday through Friday and 7 AM to 4 PM, Pacific Time, Saturday.

Days and hours of support are subject to change without notice. Toll or long distance charges may apply.

Purchase supplies and accessories

You can purchase air filters (V13H134A58), screens, and other accessories from an Epson authorized reseller. To find the nearest reseller, call 800-GO-EPSON (800-463-7766). Or you can purchase online at www.epsonstore.com (U.S. sales) or www.epsonstore.ca (Canadian sales).

Remote Control Map

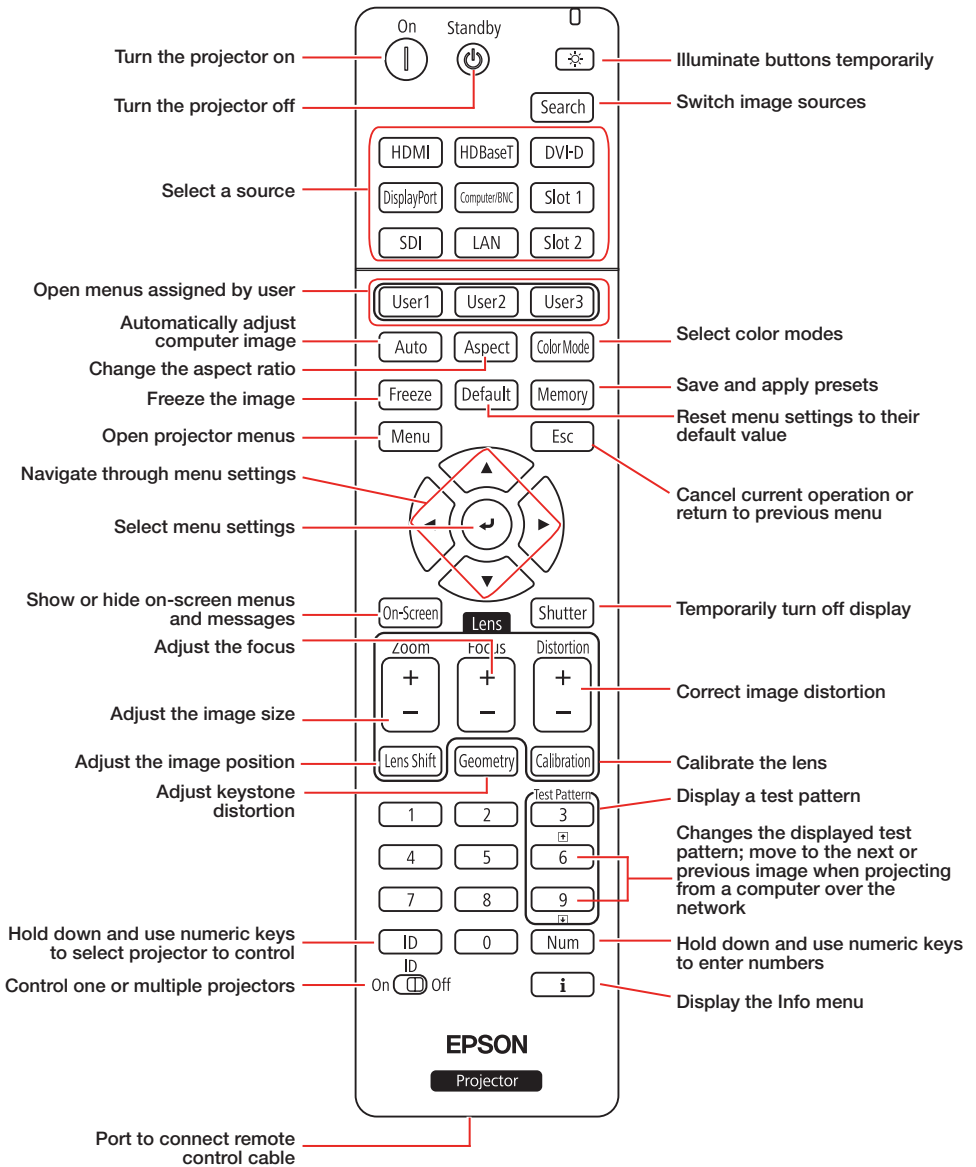

EPSON[®]
EXCEED YOUR VISION



EPSON and Quick Corner are registered trademarks and EPSON Exceed Your Vision is a registered logomark of Seiko Epson Corporation.

PrivateLine is a registered trademark of Epson America, Inc.

Windows is a registered trademark of Microsoft Corporation in the United States and/or other countries.

Mac is a trademark of Apple Inc., registered in the U.S. and other countries.

General Notice: Other product names used herein are for identification purposes only and may be trademarks of their respective owners. Epson disclaims any and all rights in those marks.

This information is subject to change without notice.

© 2019 Epson America, Inc., 9/19

CPD-56234



413670200