

# THE HYBRID KANGAROO

## HORIZONTAL BAR ADJUSTMENT INSTRUCTIONS

If you have an offset weight on your Hybrid and want to move your main monitor more in line with your eyes, by moving the entire horizontal bar left or right please follow the steps below.

Step 1: Start off by removing your monitor and laptop from the unit. Raise the unit to the standing position, tighten the brakes and slide the unit around to face the back side of the lifting assembly. Shown below.

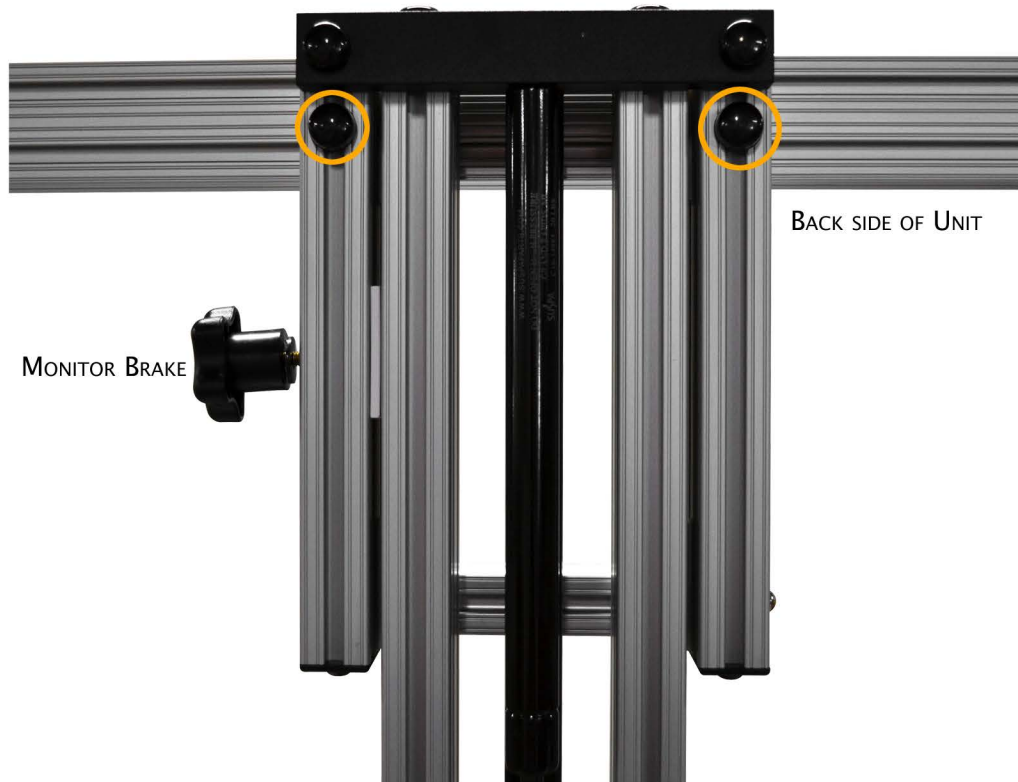

Step 2: Remove the two black plastic caps notated above with a set of pliers or a flat head screw driver.

Step 3: Loosen the two exposed bolts by only 1/2 to a full turn with a 7/16 wrench. **!!! DO NOT LOOSEN THE BOLTS FULLY, THEY WILL DISENGAGE FROM THE NUTS HOLDING THE HORIZONTAL BAR !!!**

Step 4: The Horizontal bar should now be able to slide left or right. We suggest putting the heaviest application in front of your eyes. Once you have the bar in the location you like, please tighten both loosened bolts from step 3. Once you have your monitor and laptop/secondary monitor in position and mounted, make sure the unit is still sturdy.