

THE KANGAROO ELITE - ASSEMBLY INSTRUCTIONS

Assembly Parts list

- A. (2) Black Screw Covers
- B. (2) 1/4-20 x 3.50 Hex Head Bolts
- C. (1) 5/32 Allen Wrench
- D. (2) Fender Washers
- E. (2) Acorn Nuts
- F. (3) 1/4-20 x 7/8 BHCS
- G. (2) Thick Black Washers
- H. (1) 7/16 Wrench
- I. (2) Locking Star Washers

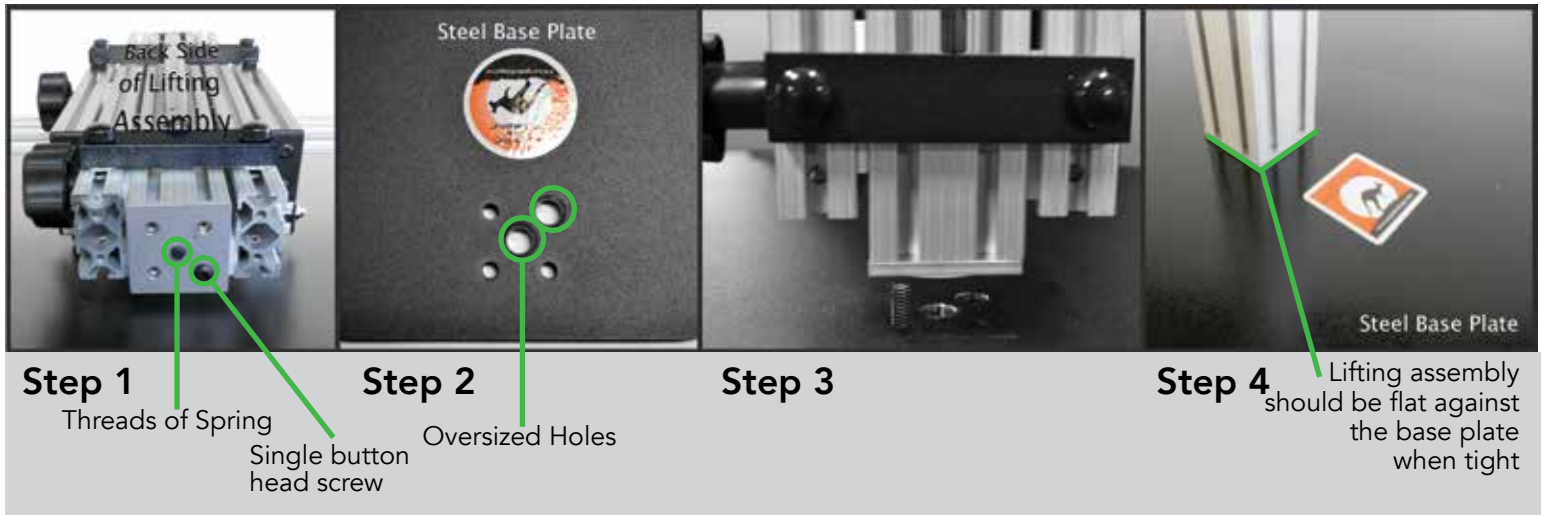

Step 1: Lay the lifting assembly on a solid surface with the back side up as shown. Notice the single Button Head Bolt in the assembly union plate. **DO NOT LOOSEN THE SINGLE BUTTON HEAD BOLT THAT IS NOTATED.**

Step 2: Notice the (2) oversized holes in the Base Plate. The Single Button Head Bolt will go into the oversized hole on the top right, while the other 3 holes should line up with the base. The center oversized hole is not used with this unit.

Step 3: With the Base Plate over hanging the table about 2 inches, hold the Lifting Assembly above the Base Plate and align the Single Button Bolt into the oversized hole. Place one 1/4-20 x 7/8 BHCS{F} through the base plate to screw in the lifting assembly.

Step 4: Insert and thread the other (2) 1/4-20 x 7/8 BHCS{F} through the Base Plate and into the Lifting Assembly. Once all (3) bolts are threaded in, tighten securely with the 5/32 allen wrench{C}. Lifting Assembly should be flat against the Base and all three bolts should look like the picture above.

THE KANGAROO ELITE - ASSEMBLY INSTRUCTIONS



Step 5: Put (1) Locking Star Washer{I} on each of the 1/4 –20 x 3.50 Hex Head Bolts{B}.

Step 6: Insert the (2) 1/4-20 x 3.50 Hex Head Bolts{B} through the holes in the Vertical Rail.

Step 7: Put (1) Fender Washer{D} on each of the 1/4-20 x 3.50 Hex Head Bolts{B} on the other side of the Vertical Rail.

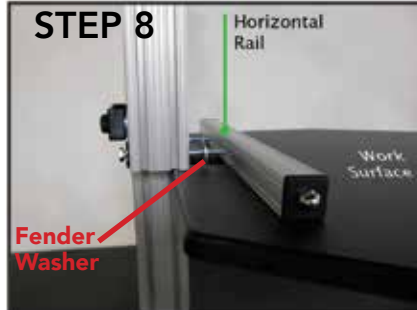

Step 8: Lift the Work Surface up and align the holes in the Horizontal Rail with the (2) 1/4-20 x 3.50 Hex Head Bolts{B}. Push the Work Surface onto the Hex Head Bolts until the threads of the bolts come through the Horizontal Rail.



Step 9: Put (1) Black Washer{G} and (1) Acorn Nut{E} on the end of each of the Hex Head Bolts. Using the 7/16 wrench{H} tighten the Acorn Nuts securely.

Step 10: Mount your monitors. Follow the mounting instructions below to mount your monitors.

A

B

ALREADY ATTACHED TO YOUR UNIT

C

M4x12 (x4) M4x30 (x4)

D

M6x12 (x4) M6x30(x4)

E

16X8X20 (x4)

F

NOT REQUIRED

M16x51 (x2) Ø8x40 (x2)

G

S=3mm (x1)

1.

Option C-D

OR

2.

Lock screw

Once slid into place use the provided allen wrench to tighten the silver set screw to lock the bracket in place.

3.

Option C-D, E

360° ±15°

60°

60mm 3.5"

THE KANGAROO ELITE



The Kangaroo Elite is designed to hold your monitors mounted in a fixed position, and will travel up and down with your keyboard and mouse on the work surface. Your Kangaroo Elite is shipped in the down position with the work surface brake tightened. The mounts may need adjusted to your desired height for both the seated and standing position.

The Kangaroo Elite has (1) spring that assists in raising your unit to the standing position and works best when your monitor and keyboard are in place. This reduces the amount of pressure needed to lower the unit.

Always push down with both hands on the horizontal rear rail when lowering the work surface.

HOW TO USE THE KANGAROO ELITE

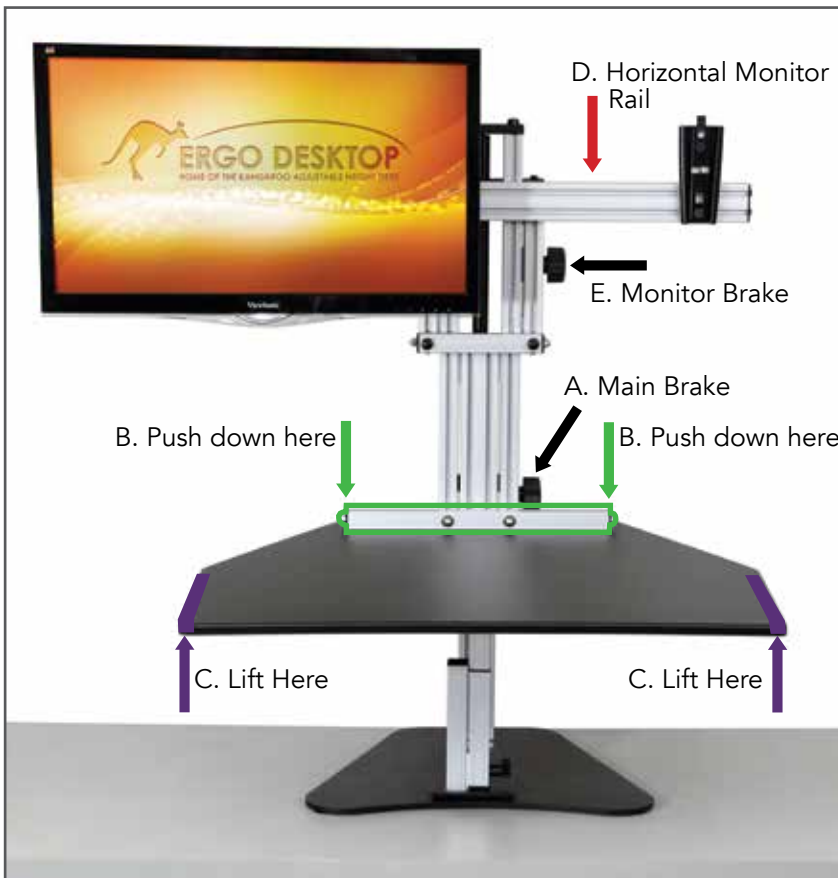

To move the mount horizontally closer or farther apart, simply loosen the bolt attached to the horizontal monitor rail (D) by a single turn with a 5/32 allen wrench. Once you have reached the desired position tighten the bolt.

To raise the Elite, loosen the main brake(A) and lift the main work surface on the sides(C & C). Once you have the work surface at the required height tighten the main brake.

To lower the Elite, loosen the main brake(A) and lean into the unit using your upper body weight pushing down with both hands on the horizontal bar at the rear of the main work surface (B & B).

Raise and lower the monitor rail by loosening the monitor brake(E) and either lift up or push down on the monitor rail(D). Once the monitors reach your desired level, tighten the monitor brake.

A. Main Brake

B. Work Surface Rail

C. Main Work Surface

D. Horizontal Monitor Rail

E. Monitor Brake

ADJUST THE STOPPING BOLT

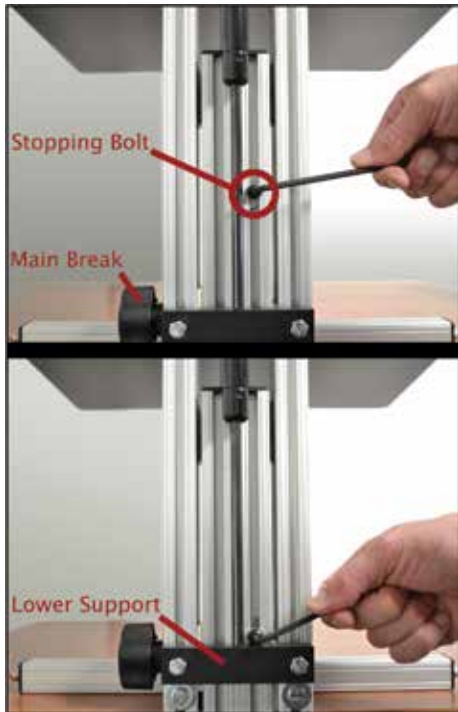

On the back side of your unit you will notice a small bolt located on the lifting tower. This bolt is used as our work surface stopper. It is currently set at 15", the highest our unit should go. This setting is for a 6'2" user on a 30" high desk. If you are shorter than this, raise the unit to your desired height and tighten the Main Brake. Adjust the stopping bolt by loosening the bolt **with one turn** and drop the bolt down to reach the lower support, and re-tighten the stopping bolt.

If you are a taller individual and need to raise the stopping bolt, please note that the work surface can get up to 16 1/2 inches but you will be raising the unit into the oil dampening zone of the spring. This makes it a little more difficult to lower the unit into the seated position when raised to this maximum point.

Our work surface should only be raised to your belt or navel line. This creates a 90-110 degree angle in your elbows which is suggested in the standing position. This will also allow you to lower the unit with ease by simply transferring your upper body weight into the back of the unit.

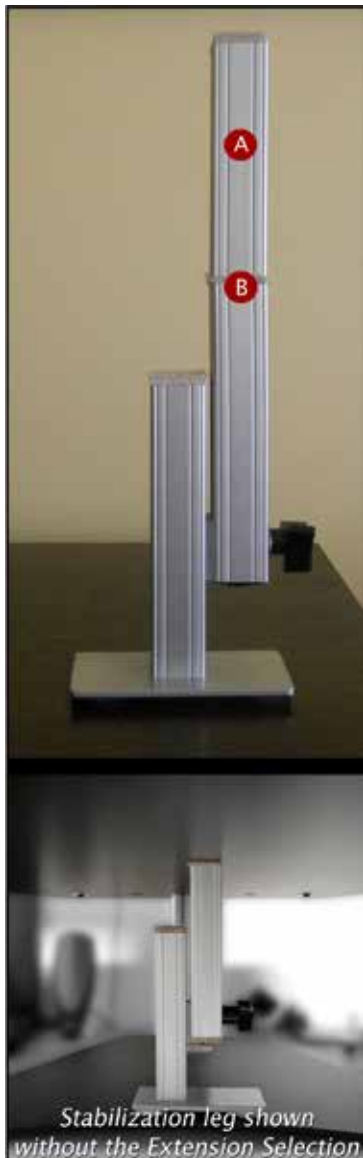

THE STABILIZATION LEG

Your adjustable height desk top unit comes with an adjustable leg that can be used to give you maximum stability when you are using "The Kangaroo" in the standing position.

Raise the Kangaroo work surface to your desired standing height and tighten the work surface brake.

Place the adjustable leg under the work surface and loosen the adjustable leg brake. Only loosen the brake by a turn or two, too much and the brake will disengage from the slot.

Extend the adjustable leg until it engages the bottom of the work surface and then tighten the adjustable leg brake.

The leg is shipped with the extension section installed to give you additional height adjustment. If this is too tall for your application, simply unscrew the extension selection.

A Extension selection

B Screws into here

ALWAYS REMEMBER TO REMOVE THE STABILIZATION LEG BEFORE LOWERING YOUR WORK SURFACE

THE KANGAROO ELITE

HORIZONTAL BAR ADJUSTMENT INSTRUCTIONS

If you have an offset weight on your Elite and want to move your main/larger monitor more in line with your eyes, by moving the entire horizontal bar left or right please follow the steps below.

Step 1: Start off by removing your monitors from the unit. Raise the unit to the standing position, tighten the brakes and slide the unit around to face the back side of the lifting assembly. Shown below.

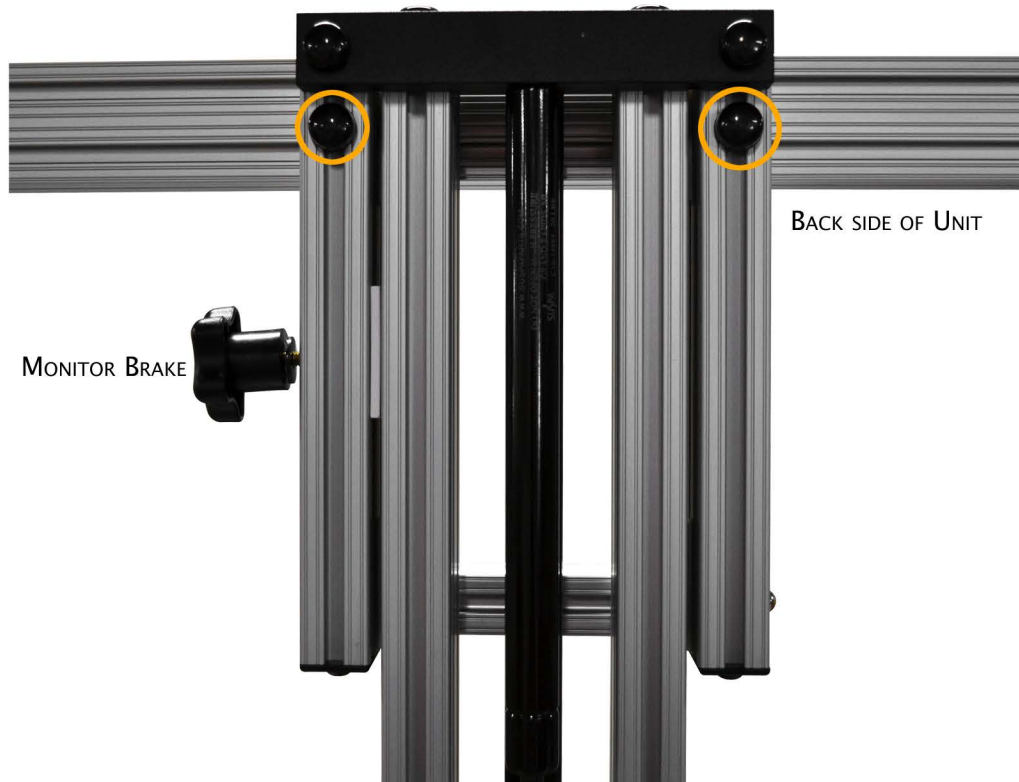

Step 2: Remove the two black plastic caps notated above with a set of pliers or a flat head screw driver.

Step 3: Loosen the two exposed bolts by only 1/2 to a full turn with a 7/16 wrench. **!!! DO NOT LOOSEN THE BOLTS FULLY, THEY WILL DISENGAGE FROM THE NUTS HOLDING THE HORIZONTAL BAR !!!**

Step 4: The Horizontal bar should now be able to slide left or right. We suggest putting the heaviest monitor in front of your eyes. Once you have the bar in the location you like, please tighten both loosened bolts from step 3. Once you have your monitors in position and mounted, make sure the unit is still sturdy.

THE KANGAROO PRO - ASSEMBLY INSTRUCTIONS

Assembly Parts list

- A. (2) Black Screw Covers
- B. (2) 1/4-20 x 3.50 Hex Head Bolts
- C. (1) 5/32 Allen Wrench
- D. (2) Fender Washers
- E. (2) Acorn Nuts
- F. (3) 1/4-20 x 7/8 BHCS
- G. (2) Thick Black Washers
- H. (1) 7/16 Wrench
- I. (2) Locking Star Washers

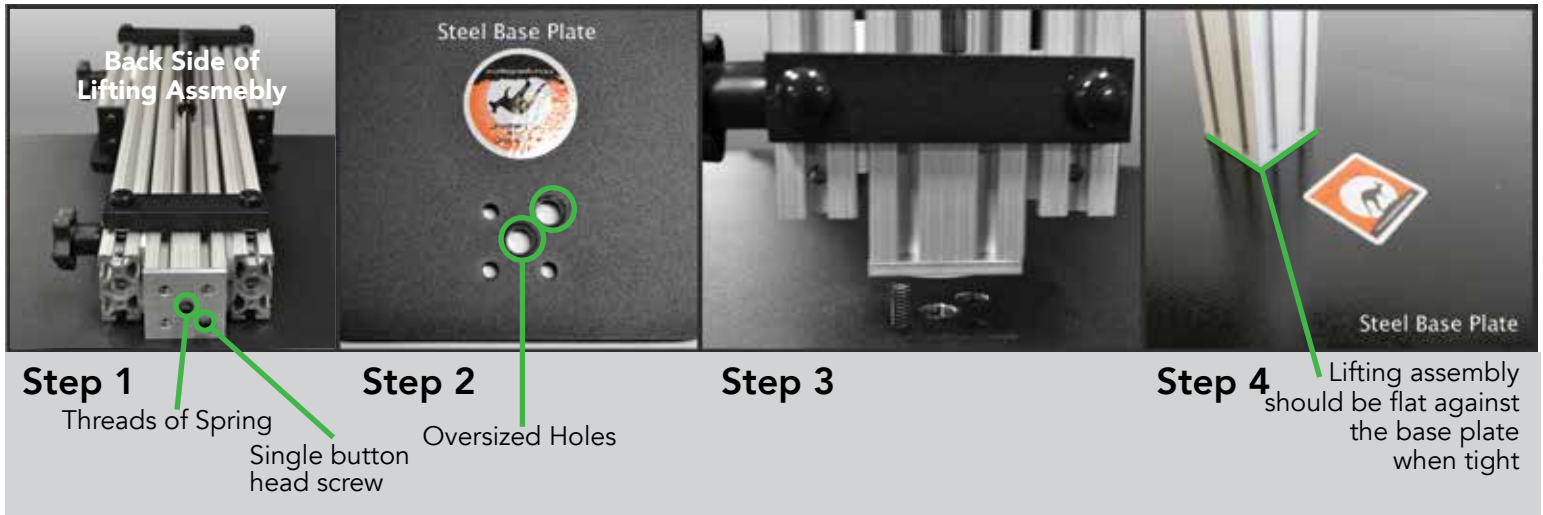

Step 1: Lay the lifting assembly on a solid surface with the back side up as shown. Notice the single Button Head Bolt in the assembly union plate. **DO NOT LOOSEN THE SINGLE BUTTON HEAD BOLT THAT IS NOTATED.**

Step 2: Notice the (2) oversized holes in the Base Plate. The Single Button Head Bolt will go into the oversized hole on the top right, while the other 3 holes should line up with the base. The center oversized hole is not used with this unit.

Step 3: With the Base Plate over hanging the table about 2 inches, hold the Lifting Assembly above the Base Plate and align the Single Button Bolt into the oversized hole. Place one 1/4-20 x 7/8 BHCS{F} through the base plate to screw in the lifting assembly.

Step 4: Insert and thread the other (2) 1/4-20 x 7/8 BHCS{F} through the Base Plate and into the Lifting Assembly. Once all (3) bolts are threaded in, tighten securely with the 5/32 allen wrench{C}. Lifting Assembly should be flat against the Base and all three bolts should look like the picture above.

THE KANGAROO PRO - ASSEMBLY INSTRUCTIONS



Step 5: Put (1) Locking Star Washer{I} on each of the 1/4 –20 x 3.50 Hex Head Bolts{B}.

Step 6: Insert the (2) 1/4-20 x 3.50 Hex Head Bolts{B} through the holes in the Vertical Rail.

Step 7: Put (1) Fender Washer{D} on each of the 1/4-20 x 3.50 Hex Head Bolts{B} on the other side of the Vertical Rail.

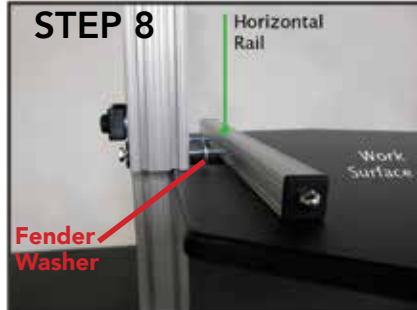

Step 8: Lift the Work Surface up and align the holes in the Horizontal Rail with the (2) 1/4-20 x 3.50 Hex Head Bolts{B}. Push the Work Surface onto the Hex Head Bolts until the threads of the bolts come through the Horizontal Rail.



Step 9: Put (1) Black Washer{G} and (1) Acorn Nut{E} on the end of each of the Hex Head Bolts. Using the 7/16 wrench{H} tighten the Acorn Nuts securely.

Step 10: Mount your monitor. Follow the mounting instructions below to mount your monitor.

A

B

ALREADY ATTACHED TO YOUR UNIT

1.

Option C-D

OR

Option E

C

M4x12 (x4) M4x30 (x4)

D

M6x12 (x4) M6x30 (x4)

E

16X8X20 (x4)

F

NOT REQUIRED

M1x01 (x2) Ø8x40 (x2)

G

S=3mm (x1)

2.

Lock screw

B

3.

±15°

360°

60°

90mm

3.5"

THE KANGAROO PRO



The Kangaroo Elite is designed to hold your monitors mounted in a fixed position, and will travel up and down with your keyboard and mouse on the work surface. Your Kangaroo Elite is shipped in the down position with the work surface brake tightened. The mounts may need adjusted to your desired height for both the seated and standing position.

The Kangaroo Elite has (1) spring that assists in raising your unit to the standing position and works best when your monitor and keyboard are in place. This reduces the amount of pressure needed to lower the unit.

Always push down with both hands on the horizontal rear rail when lowering the work surface.

HOW TO USE THE KANGAROO PRO

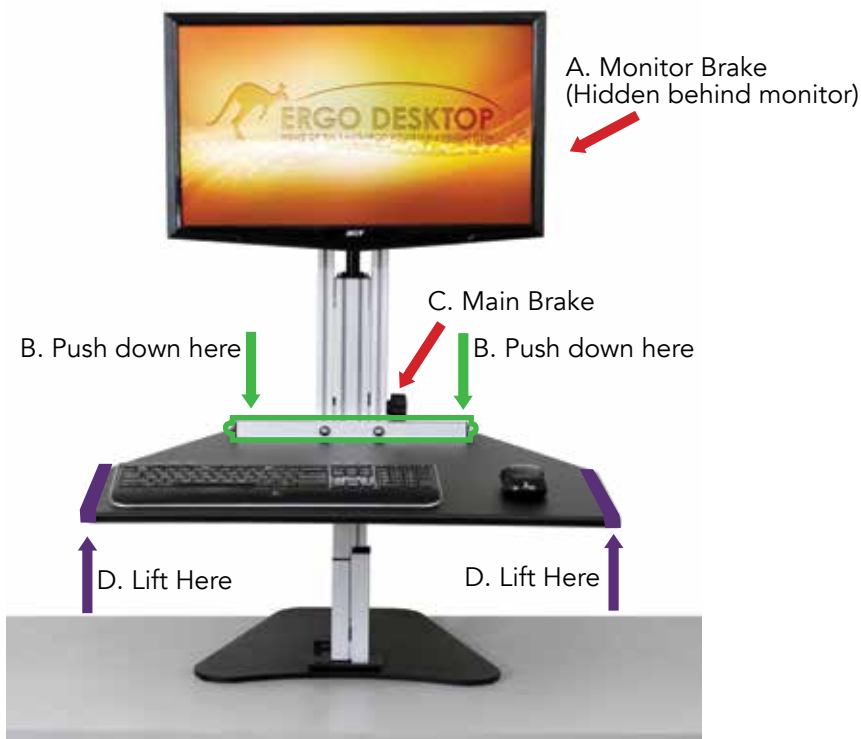

To raise the Kangaroo Pro, loosen the main brake(C) and lift the main work surface on the sides(D & D).

To raise the monitor, loosen the monitor brake(A), and raise the monitor with two hands. Once the desired height is reached, tighten the monitor brake.

To lower the Kangaroo Pro, loosen the main brake(C) and lean into the unit using your upper body weight pushing down with both hands on the horizontal bar at the rear of the main work surface (B & B).

To Lower the monitor, loosen the monitor brake(A) and push down with one or two hands on the monitor.

A. Monitor Brake

B. Work Surface Rail

C. Main Brake

D. Main Work Surface

ADJUST THE STOPPING BOLT

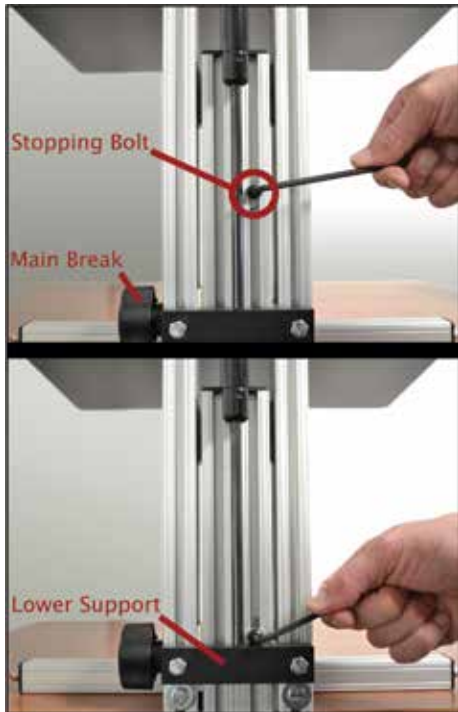

On the back side of your unit you will notice a small bolt located on the lifting tower. This bolt is used as our work surface stopper. It is currently set at 15", the highest our unit should go. This setting is for a 6'2" user on a 30" high desk. If you are shorter than this, raise the unit to your desired height and tighten the Main Brake. Adjust the stopping bolt by loosening the bolt **with one turn** and drop the bolt down to reach the lower support, and re-tighten the stopping bolt.

If you are a taller individual and need to raise the stopping bolt, please note that the work surface can get up to 16 1/2 inches but you will be raising the unit into the oil dampening zone of the spring. This makes it a little more difficult to lower the unit into the seated position when raised to this maximum point.

Our work surface should only be raised to your belt or navel line. This creates a 90-110 degree angle in your elbows which is suggested in the standing position. This will also allow you to lower the unit with ease by simply transferring your upper body weight into the back of the unit.

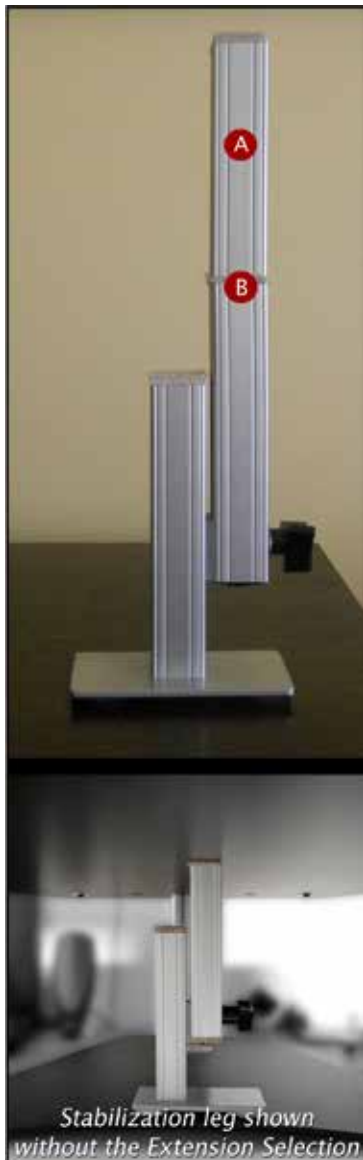

THE STABILIZATION LEG

Your adjustable height desk top unit comes with an adjustable leg that can be used to give you maximum stability when you are using "The Kangaroo" in the standing position.

Raise the Kangaroo work surface to your desired standing height and tighten the work surface brake.

Place the adjustable leg under the work surface and loosen the adjustable leg brake. Only loosen the brake by a turn or two, too much and the brake will disengage from the slot.

Extend the adjustable leg until it engages the bottom of the work surface and then tighten the adjustable leg brake.

The leg is shipped with the extension section installed to give you additional height adjustment. If this is too tall for your application, simply unscrew the extension selection.

A Extension selection

B Screws into here

ALWAYS REMEMBER TO REMOVE THE STABILIZATION LEG BEFORE LOWERING YOUR WORK SURFACE