

**LearnFit**<sup>®</sup>  
by *ERGOTRON*<sup>®</sup>

Height-Adjustable  
Sit-Stand Desks for  
Active Students



Dear Students & Educators,

Here is your first high-five for taking the steps towards a more productive and active classroom! Considering to integrate LearnFit® Sit-Stand Desks into your classrooms is a great first step in achieving those goals. As we all know, **kids are meant to move!**

To help you and your schools get started with “rolling out” a LearnFit classroom, we have assembled this Getting Started kit. In it, you’ll find background information and ideas on how you could use your LearnFit in your own classroom. You are a pioneer – we hope that you can springboard off of these ideas to create your own truly dynamic environment that’s just right for you and your school.

Online Resources:

- [LearnFit Product Information](#)
- [Ergotron Spotlight Schools](#): Hear what teachers, administrators and students are saying about their LearnFit experience
- [Education Research](#): Visit this link for the latest sit-stand research in education

Collaborate with us! Follow Us on [Twitter](#) with #learnfit or check us out on [Facebook](#) and [Pinterest](#)!

We hope that you find this kit helpful. We are always open to suggestions and feedback that you may have so please feel free to [contact us](#) and share!

Sincerely,  
Ergotron’s LearnFit Team





# Features



Tablet slot



Water bottle holder



Pencil tray



Lever for height adjustment



Backpack hook

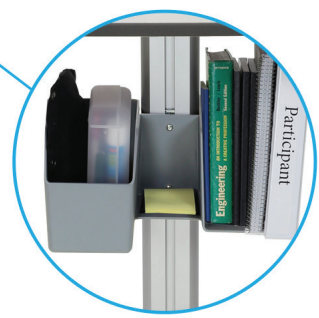

Storage basket (optional)

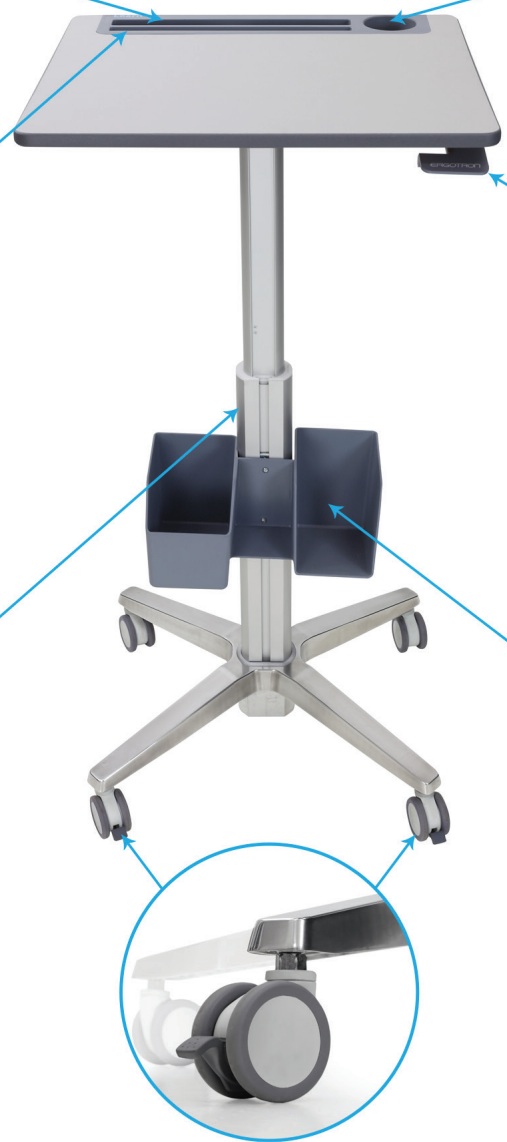

Locking casters





# Easy 2-step Assembly

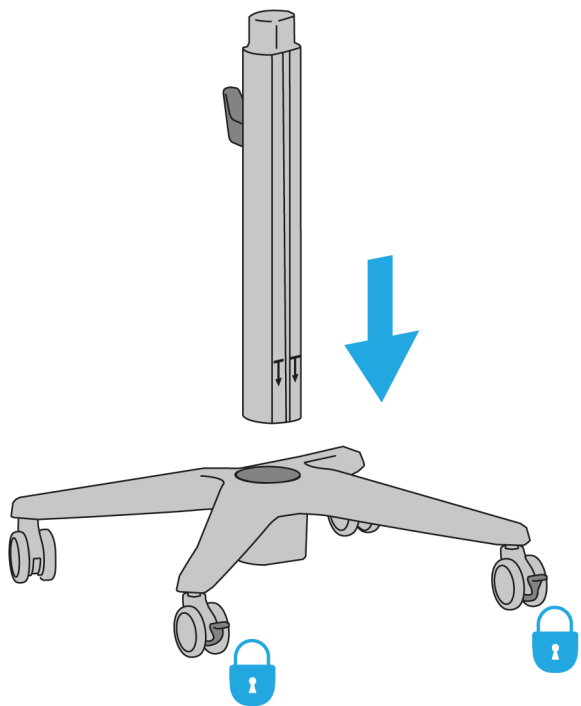

1

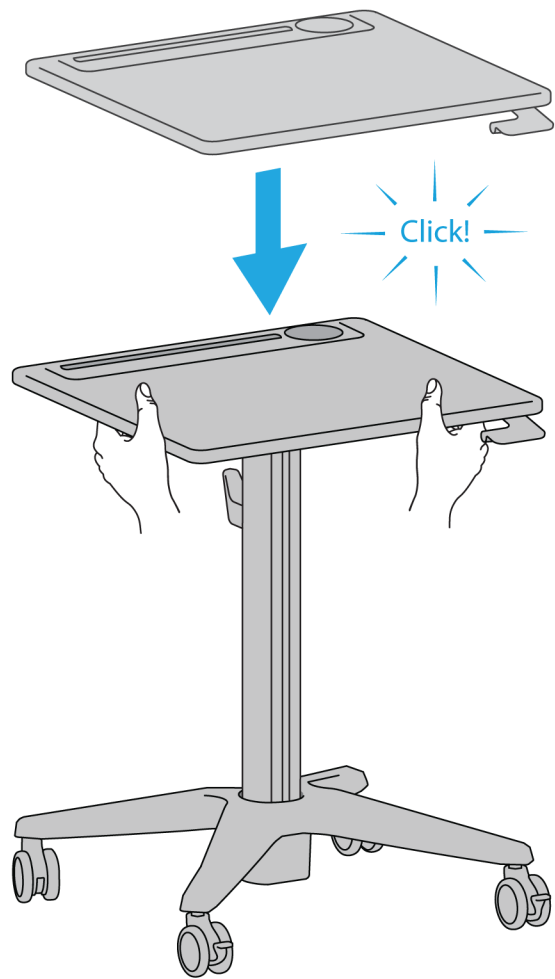

2





# Room Layout Ideas

Rows

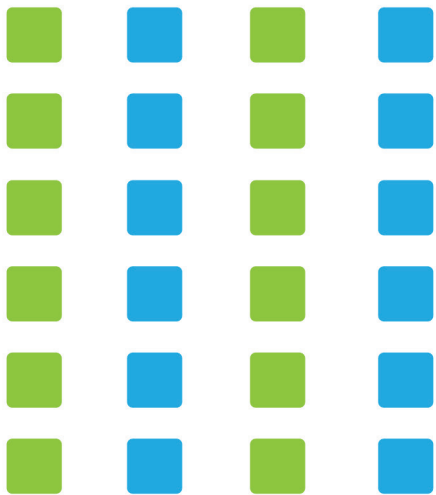

Groups

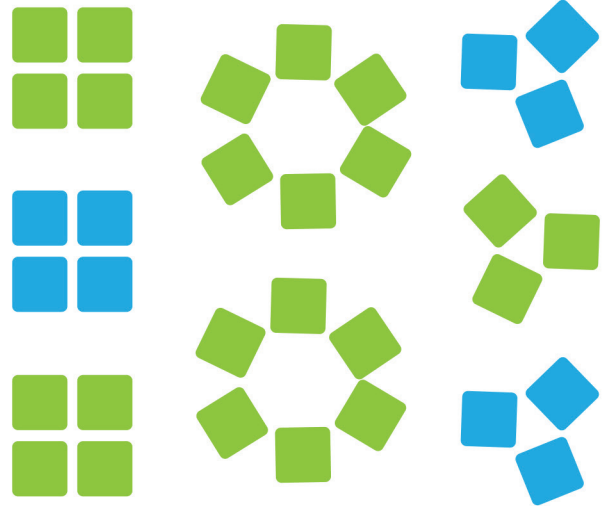

Instruction

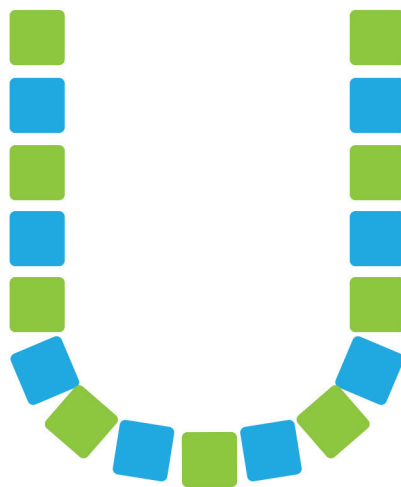



A body in motion stays in motion ~ Isaac Newton

## How do we keep our students in motion?

### PROBLEM

Today's sedentary lifestyles are affecting our youth and their classroom performance. Compound this with pressures to sacrifice physical education time for more classroom time for the core subjects.

### CHALLENGE

How do we increase in-class physical activity to help our students' overall health and performance?

### INTRODUCING: THE LEARNFIT® SIT-STAND DESK

Transform classrooms into active learning environments with on-demand height-adjustable student desks.

Studies show that introducing low-level physical activity into the classroom has a positive impact on student health, classroom engagement and academic performance.

### HEALTH BENEFITS



#### INCREASE HEART RATE <sup>1</sup>

Oxygen is essential for brain function, and enhanced blood flow increases the amount of oxygen transported to the brain.



**Heart Rate**  
Significant increase in heart rate from seated to standing work = 10 bpm (p = .012)



#### MAINTAIN INSULIN EFFECTIVENESS <sup>1</sup>

The low-level physical activity of standing requires many unconscious muscle contractions, which stimulates insulin signaling, resulting in more effective insulin function and overall more healthy long-term blood/glucose levels. <sup>3</sup>



**Blood Glucose\***  
\*The concentration of sugar in the blood  
Seated peak to trough 106 minutes  
Standing peak to trough 60 minutes



#### BURN MORE CALORIES <sup>1</sup>

Studies show that standing throughout the day instead of just sitting can burn 40 extra calories per hour.

Subjects in the 85th percentile in weight for their age and gender who used the standing desks experienced a 32% increase in calorie expenditure compared with those in the control group. <sup>2</sup>



**Calorie (kcal) Expenditure**  
Significant increase in calorie expenditure from seated to standing work = 0.7 kcals/minute (p = .014)





## CLASSROOM ENGAGEMENT

Maintaining low-level physical activity – such as standing in the classroom – not only has positive health effects, but also results in greater student focus and attention. Increased blood circulation and oxygenation leads to alert and engaged students. “Standing actually improved attention, on-task behavior, alertness and classroom engagement.”<sup>2</sup>

## ACADEMIC PERFORMANCE

Greater focus and engagement during everyday class time builds preparedness, combined with greater alertness during test time helps lead to greater academic performance. Sustained healthy metabolism leads to greater everyday classroom focus, which has a positive effect on test scores. “Children who are more active performed better on standardized tests, and showed greater attention and faster thinking skills than did children who are less active.”<sup>4</sup>

- Encourages healthy student behavior that leads to physical and academic improvements
- Looking sharply down at a digital learning device puts excessive pressure on the neck. PrecisionHeight™ Technology provides a healthier way to learn – students simply adjust the height of the desktop for easier viewing and to help reduce neck strain
- Using the hand lever, each student instantly and intuitively personalizes the desk to his or her preferred height
- No need for school staff to make adjustments before, during or after school hours
- One size fits all – height adjustment range is designed for students ages 9 through adult
- Mobile, locking casters – easily roll the LearnFit desks to quickly reconfigure classrooms for small group collaborative breakouts, and easily return to full classroom configuration when done
- Tablet slot, water bottle holder and backpack hook included
- Super durable worksurface construction stands up to demanding classroom conditions
- Optional LearnFit Storage Bin provides three separate compartments for storing student supplies; adjustable Classroom Stool supports sit-stand activity
- Assembles in less than 60 seconds; no tools required





# Story Rounds Activity

Divide the class up into 4 groups and give them a story topic. Move the LearnFit desks into your appropriate group. Students in the 1<sup>st</sup> group will write the first paragraph and then pass on to the next group for them to write the second paragraph and so on. The 1<sup>st</sup> group should write the final paragraph and can also edit for spelling and punctuation if desired. Then the class reads the story out loud.

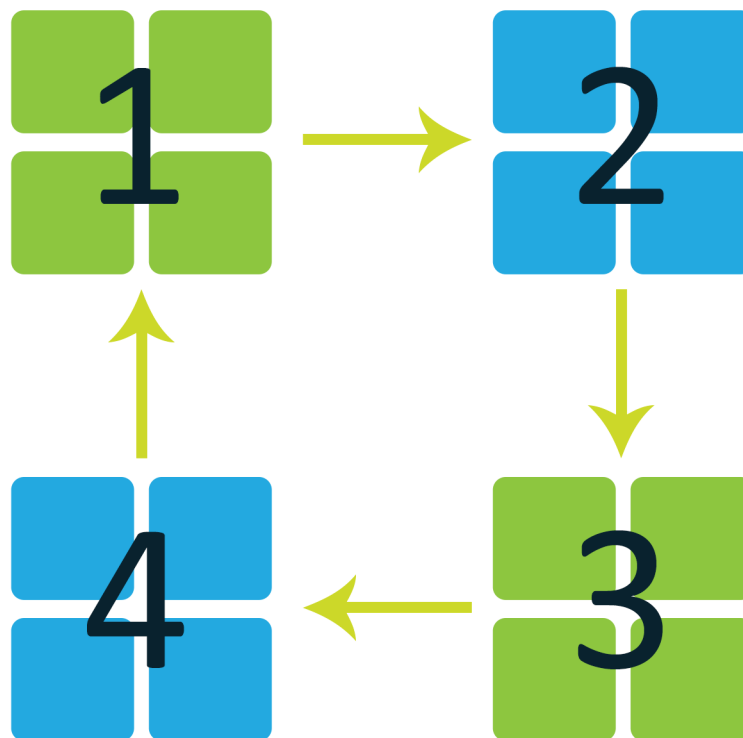





# Math Matching Game

Divide the class in two groups. Give the first group math problems and the second one the answers. Students with the math problems need to move their desk to the students holding the correct answers.

**Tip:** Laminate your cards for future use.

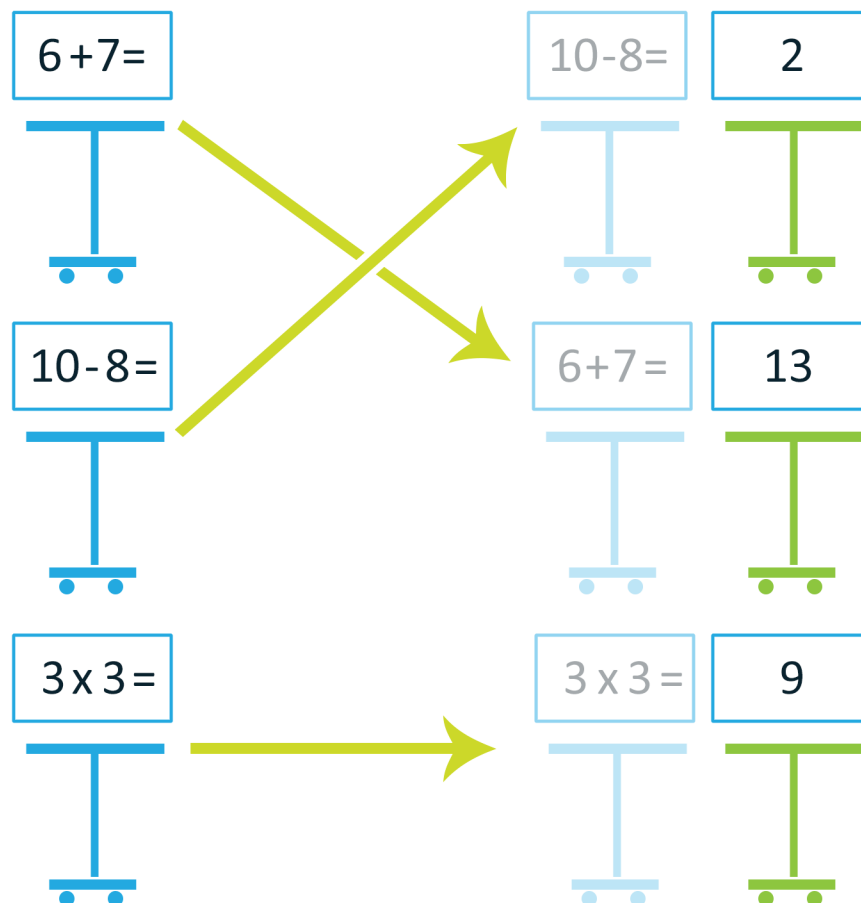

# Solar System Game

Line up nine LearnFit desks with the “Sun” card on the 1<sup>st</sup> one. Pick eight students. Hand each student a card with the name of a planet in random order. Have the students display their cards on the LearnFit desks in order of the solar system. Teach them about rotation around the sun. If space allows, have the students move the desks to rotate around the “Sun” LearnFit.

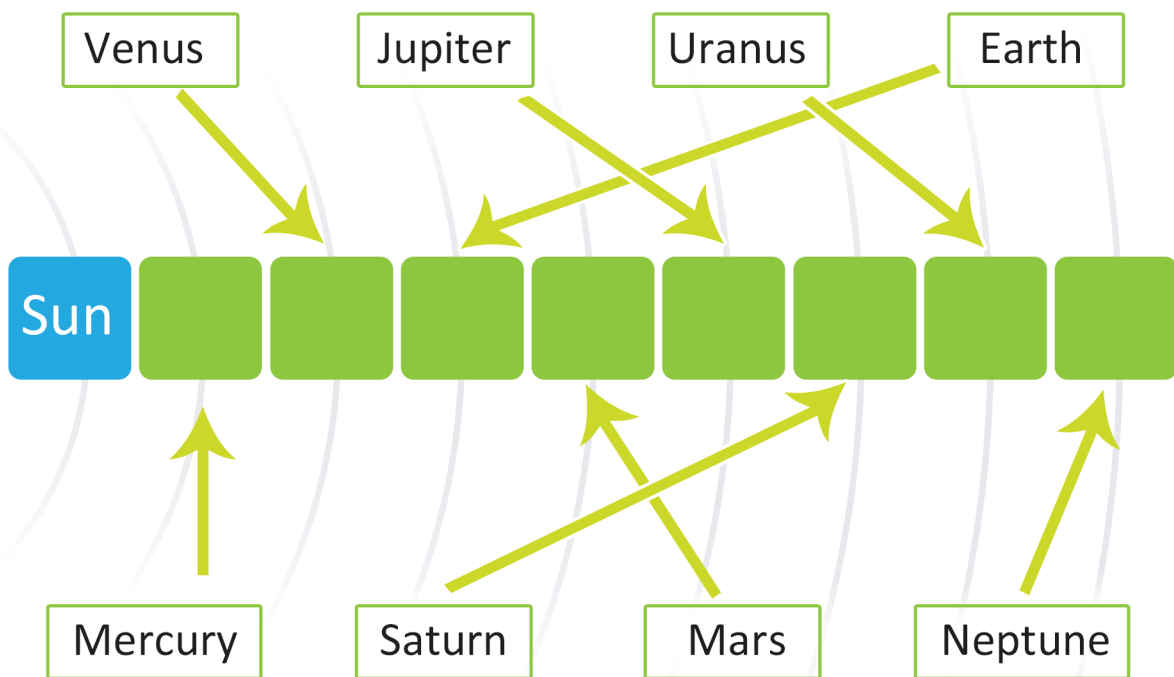



# Research & Presentation Project

## Reducing Sedentary Behavior and Introducing Standing into the Classroom and Workplace

Divide the class into 6 small collaborative groups by moving their LearnFit desks to different parts of the classroom. Each group should work together to research, develop content and organize a presentation for an assigned topic below.



1 Sedentary Trends & Health Impact



4 The Link Between Physical Activity, Learning & Productivity



2 Health Benefits of Introducing Standing into the Classroom



5 The Link Between Physical Activity & Academic Performance



3 Classroom Benefits of Introducing Standing into the Classroom



6 Long Term Benefits of Reducing Sedentary Behaviors

A delegate from each group should work together to develop an introduction and conclusion to the presentation. For the final group presentations, LearnFit desks can be rolled to form a “U” to focus on presenting classmates.

**Tip:** This would make a good article for the school newspaper.

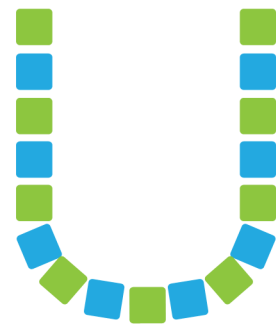



# Language Arts

## Short Story Analysis

Divide the class into 6 groups to analyze different aspects of short stories or other literature. Within each group, have students sound-off 1 through 4. Each group begins discussing the assigned element. After a short time, the teacher calls out for those numbered 1/2/3/4 to rotate around the room clockwise to the next literary element group to join and contribute to that discussion.



Setting



Character



Plot



Point of View



Conflict



Theme





It helps me pay attention longer, because when I'm sitting it's easier for me to doze off, and when I'm standing it keeps my energy up.

**K**

Kara  
8th Grader  
Montera Middle School  
Oakland, CA



My experience is that it's a fundamentally unreasonable thing that we ask kids to do - to sit and pay attention for 6 hours a day from K through 12.

**K**

Krishna  
8th Grade Math Teacher  
Montera Middle School  
Oakland, CA



Some students can sit for hours and that's great, but others can't. So having a system that allows students to be standing and having energy flowing without being disruptive is great.

**A**

Ashanti  
Assistant Principal  
Montera Middle School  
Oakland, CA



I like how you can change the height of the desk to make it personalized to you.

**N**

Noah  
8th Grader  
Montera Middle School  
Oakland, CA



It gives you more energy because you're not just sitting down.

**P**

Paloma  
8th Grader  
Montera Middle School  
Oakland, CA



The mobility aspect has opened so many doors.

**M**

Melissa  
4th Grade Teacher  
Belle Terre  
Elementary School  
Palm Coast, FL





# Resources

**ERGOTRON®**



@Ergotron

[education.ergotron.com](http://education.ergotron.com)

For LearnFit case studies  
and product information



ErgotronInc



[juststand.org](http://juststand.org)

For research on the benefits  
of standing and moving  
in the classroom



#LearnFit

see our spotlight on  
the classroom board



#LearnFit

- 1 University of Chester BBC Study, Cardiovascular and metabolic markers among office workers when standing vs. sitting, Dr. John Buckely et. al., 2013
- 2 The Impact of Stand-Biased Desks in Classrooms on Calorie Expenditure in Children, Benden, Blake, Wendel, Huber, published in American Journal of Public Health, August 2011
- 3 Minimal Intensity Physical Activity (Standing & Walking) of Longer Duration Improves Insulation Action and Plasma Lipids More than Shorter Periods of Moderate to Vigorous Exercise (Cycling) in Sedentary Subjects When Energy Expenditure is Comparable, Duvivierk, Schaper, Bremers, van Crombrugge, Menheere, Kars, Savelberg, Maastricht University, Department of Internal Medicine, Maastricht University Maastricht Centre, Maastricht, the Netherlands
- 4 Educating the Student Body: Taking Physical Activity and Physical Education to School, The Institute of Medicine of the National Academies

For more information, or to read these studies yourself, visit [www.JustStand.org](http://www.JustStand.org)



# Action Plan for Students

What you can do to take a stand against sitting.

- Create a PSA (Public Service Announcement) video about sitting disease. Remember, have fun with it! You could go retro and make the video in black and white like the old-school PSAs. Or maybe have a very serious person in a suit warning you against some crazy scenario (think sitting in a chair all day makes it easier for the zombies to catch you).
- Write an article for your school paper or newsletter about the benefits of standing more throughout the day. Or why you think it would be cool to have LearnFit in your classroom.
- If you already have LearnFit in your classroom, send a care package to other schools in your district to get them excited about the standing movement. You could include any videos or newspaper stories you created, as well as letters or quotes from your friends on why they like standing. Don't forget to include some swag in the package like pins or stickers.
- Share! The best way to get the word out is to talk about it.



# Notes / Doodles



[education.ergotron.com](http://education.ergotron.com)