

### Dual Display Arm

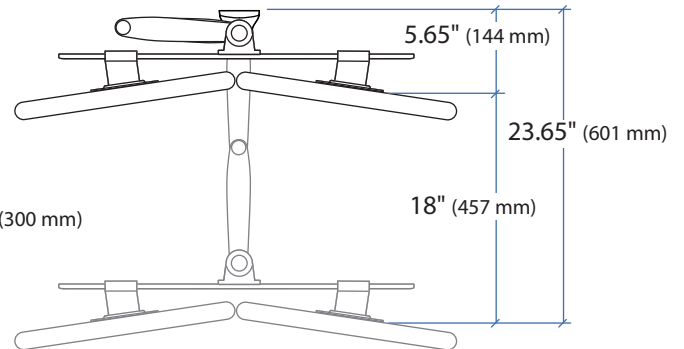

Top View

#### Wall Mount Bracket

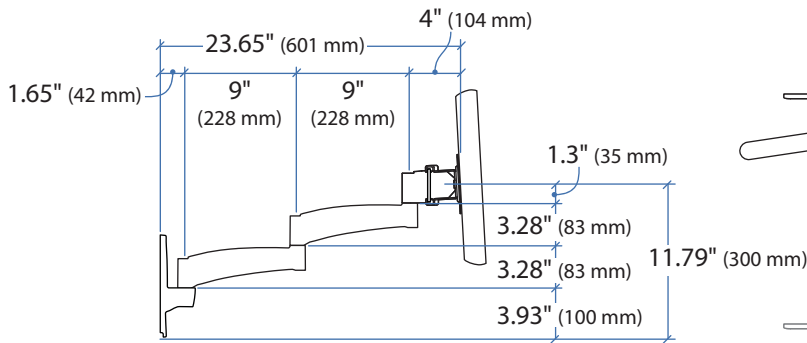
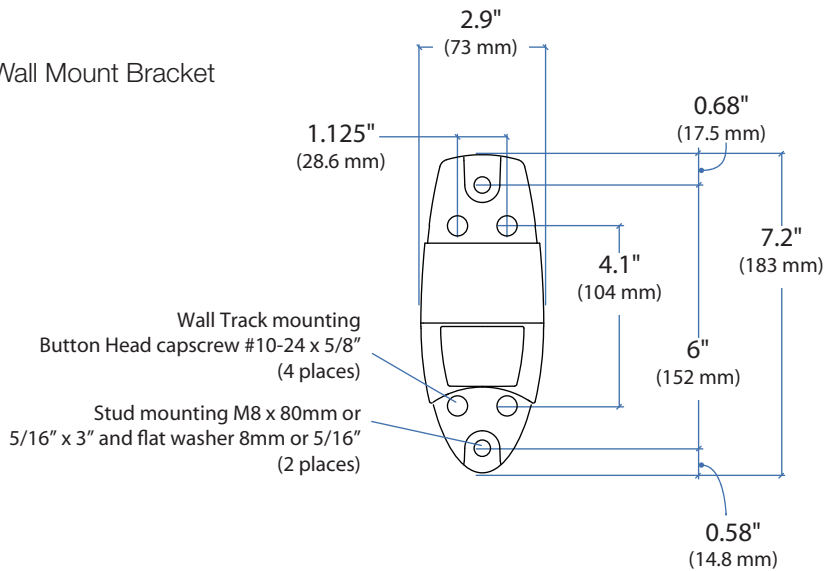

#### Maximum Monitor Width

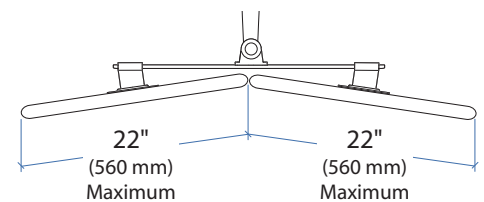

#### Range of Motion

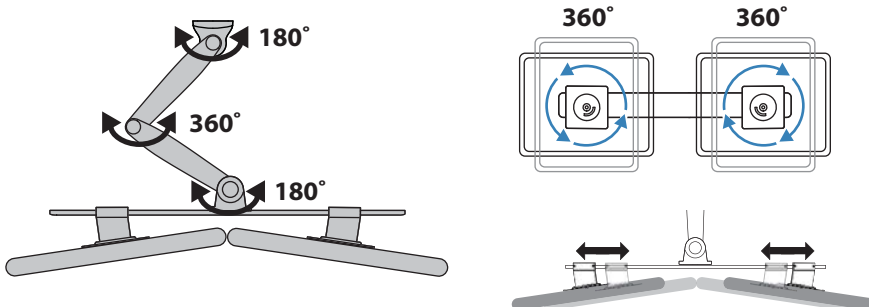

#### Maximum Weight Capacity

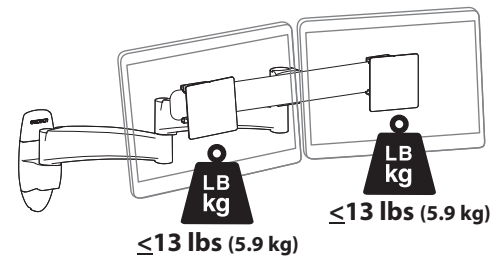

© 2010 Ergotron, Inc. rev. 02/10/2010 DIM-200 Dual Content is subject to change without notification

#### Americas Sales and Corporate Headquarters

St. Paul, MN USA  
(800) 888-8458  
+1-651-681-7600  
www.ergotron.com  
sales@ergotron.com

#### EMEA Sales

Amersfoort, The Netherlands  
+31 33 45 45 600  
www.ergotron.com  
info.eu@ergotron.com

#### APAC Sale

Tokyo, Japan  
www.ergotron.com  
apaccustomerservice@ergotron.com

#### Worldwide OEM Sales

www.ergotron.com  
info.oem@ergotron.com

