

4x

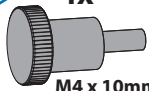

M4 x 10mm

4x



M4 x 10mm

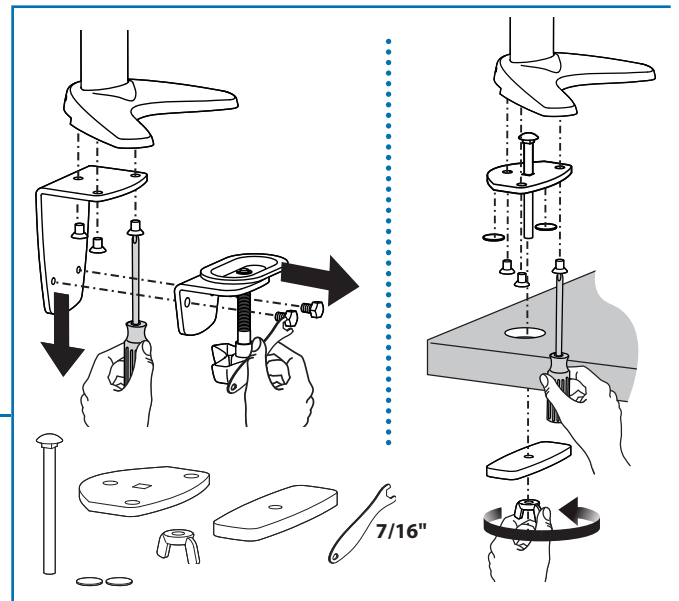
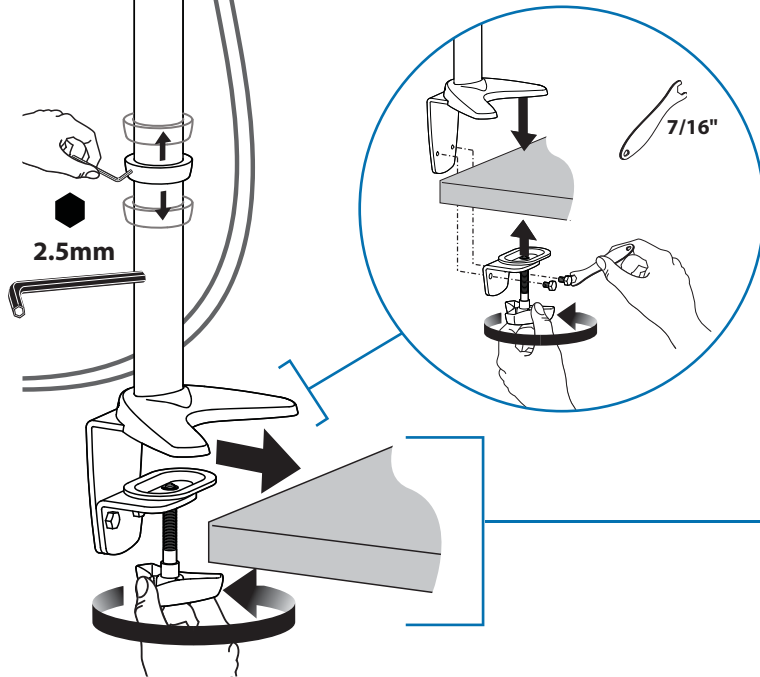
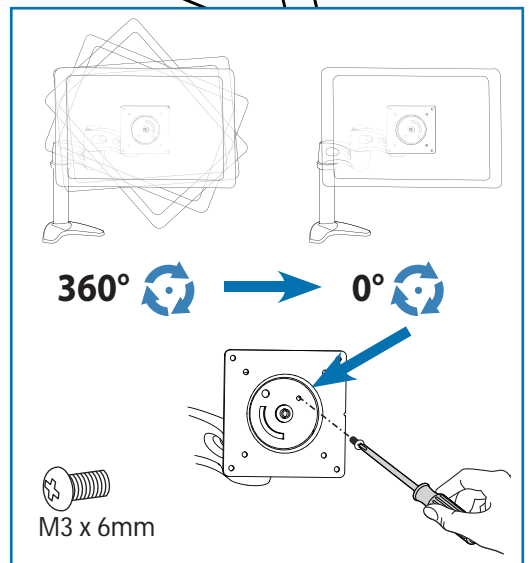



# Adjustment

# Ajuste Réglage

# Einstellung Instellen

# Regolazione 調整

# 调节

Follow these instructions to tighten or loosen tension.  
 Siga estas instrucciones para ajustar o aflojar la tensión.  
 Suivez ces instructions pour desserrer ou resserrer la tension.  
 Befolgen Sie diese Anleitung, um die Spannung zu lockern oder zu verstärken.  
 Volg deze instructies om de spanning te vergroten of te verkleinen.

Seguire queste istruzioni per aumentare o ridurre la tensione di bloccaggio.  
 压力を増減するには次の手順に従います。  
 遵照这些说明拧紧或拧松。

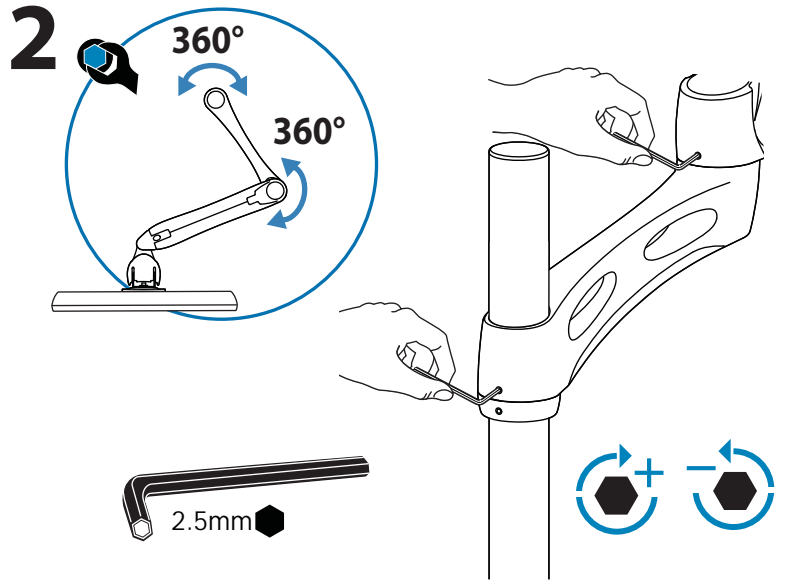
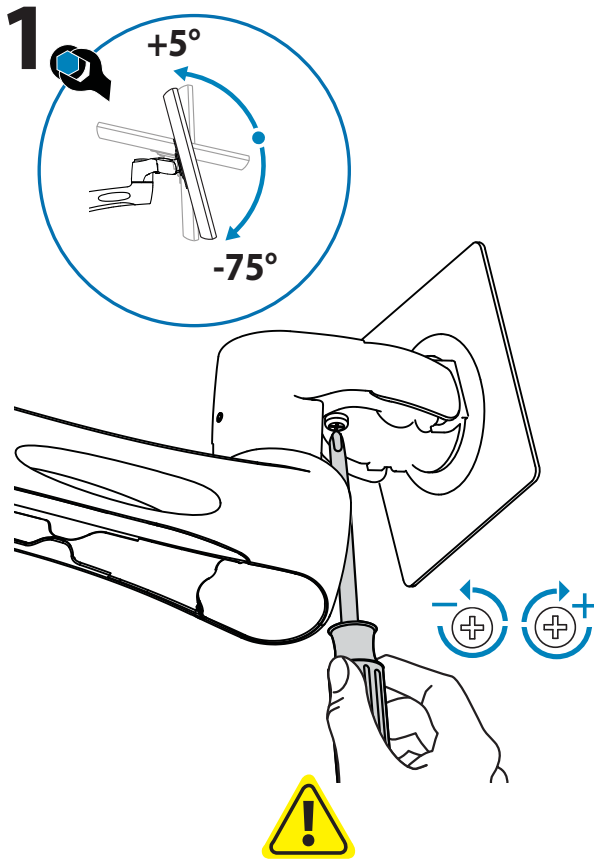

**CAUTION: DO NOT** remove screw. Removing screw may cause damage to equipment.

**Cuidado: NO quite el tornillo!** Quitar el tornillo puede causar daños en el equipamiento.

**Attention : N'ENLEVEZ PAS la vis !** Enlever la vis pourrait endommager votre équipement.

**Achtung: Bitte entfernen Sie unter keinen Umständen die Stellschraube.** Das Entfernen dieser Stellschraube führt zu Beschädigungen an Schwenkarm und Monitor.

**Let op: verwijder GEEN schroeven!** Het verwijderen van schroeven kan schade aan de apparatuur veroorzaken.

**Attenzione: NON rimuovere le viti!** Ciò potrebbe causare danno all'apparecchiatura.

**注意: ネジは取り外さないようにしてください。**ネジを取り外すと、器具が破損する原因となります。

**小心: 不要拆除螺丝。**拆除螺丝可能会损坏设备。

## Ergotron Limited Warranty

Ergotron warrants that its products will remain free of defects in material and workmanship for five (5) years. All subject to the exceptions, exclusions and limitations as set forth below.

Exceptions to this warranty include:

- Three (3)-year warranty on all Neo-Flex™ by Ergotron products
- StyleView Carts:
  - Two (2)-year warranty on all power supply components by Ergotron
  - Battery carries an up to a one (1)-year performance warranty (see Limitations below) and six (6)-month warranty against manufacturer's defects. Note: In EU, the warranty against manufacturer's defects is two (2)-years.
  - One (1)-year warranty on all electronic non-power supply components (excludes AA batteries)
- OEM products resold by Ergotron are warranted by the respective manufacturer
- Product that is refurbished by Ergotron and sold by Ergotron carries a 90-day warranty
- Thirty (30)-day warranty on all service programs
- Ergotron warranties are nontransferable

**Exclusive Remedy:** If any Ergotron equipment is or becomes defective in material or workmanship during the warranty period, Ergotron will determine with the customer if the product defect is covered under warranty. Ergotron, at its sole discretion, may replace or repair the unit determined to be under warranty at a designated Ergotron location or at the customer location. The purchaser must get pre-approved authorization to return product to Ergotron. The Purchaser must contact Ergotron to obtain an RMA (Return Material Authorization) number. Ergotron will promptly repair or replace the item and ship it to Purchaser at no charge to the Purchaser. Performance of repair or replacement does not renew or extend the warranty period.

**THIS REMEDY IS THE EXCLUSIVE REMEDY FOR BREACH OF WARRANTY AS TO THE EQUIPMENT,** except in respect to personal injury. Purchaser shall give Ergotron immediate written notice of any personal injury resulting from use of Ergotron equipment.

**Exclusions and Limitations:** Ergotron disclaims liability for injuries or losses caused by or associated with installation or use of its equipment in any manner other than in strict conformance with the instructions set forth in its installation manuals, supplemental assembly and installation instruction sheets, technical bulletins or product literature, or by equipment that has been altered, damaged or misused.

Warranty on fully charged batteries left in an unused state for more than three (3) consecutive months is automatically void. Warranty on fully discharged batteries left in an unused state for more than three (3) consecutive days is automatically void.

Two (2)-year warranty on all power supply components by Ergotron; battery carries a 90 day performance warranty and six (6) month warranty against manufacturer's defects. Performance warranty is extended to 1 year on the battery providing:

- StyleLink software is installed and it shows compliance with exclusions and limitations
- Battery is not discharged below 25% capacity more than 25 times
- Battery is fully recharged at least once every 36 hours

Purchaser is not relied upon and Ergotron disclaims any and all warranties other than the expressed warranty stated above, subject to the exclusions and limitations provided herein. Ergotron disclaims all other warranties, expressed or implied, including but not limited to the warranties of merchantability and fitness for a particular purpose. Ergotron further disclaims liability to purchaser and all others for all consequential, incidental and special damages caused by or in connection with the products, their use or misuse, and their performance or nonperformance.

While Ergotron, Inc. makes every effort to provide accurate and complete information on the installation and use of its products, it will not be held liable for any editorial errors or omissions (including those made in the process of translation from English to another language), or for incidental, special or consequential damages of any nature resulting from furnishing this instruction and performance of equipment in connection with this instruction. Ergotron, Inc. reserves the right to make changes in the product design and/or product documentation without notification to its users. For the most current product information, or to know if this document is available in languages other than those herein, please contact Ergotron. No part of this publication may be reproduced, stored in a retrieval system, or transmitted in any form or by any means, electronic, mechanical, photocopying, recording or otherwise without the prior written consent of Ergotron, Inc., 1181 Trapp Road, Eagan, Minnesota, 55121, USA Patents Pending and Patented U.S. & Foreign. Ergotron is a registered trademark of Ergotron, Inc.

## Americas Sales and Corporate Headquarters

St. Paul, MN USA  
 (800) 888-8458  
 +1-651-681-7600  
 www.ergotron.com  
 sales@ergotron.com

## EMEA Sales

Amersfoort, The Netherlands  
 +31 33 45 45 600  
 www.ergotron.com  
 info.eu@ergotron.com

## APAC Sales

Tokyo, Japan  
 www.ergotron.com  
 info.apac@ergotron.com

## Worldwide OEM Sales

www.ergotron.com  
 info.oem@ergotron.com