

Ergotron® LX

Dimensional & Range of Motion Illustrations

Wall Mount LCD Arm

Dimensions

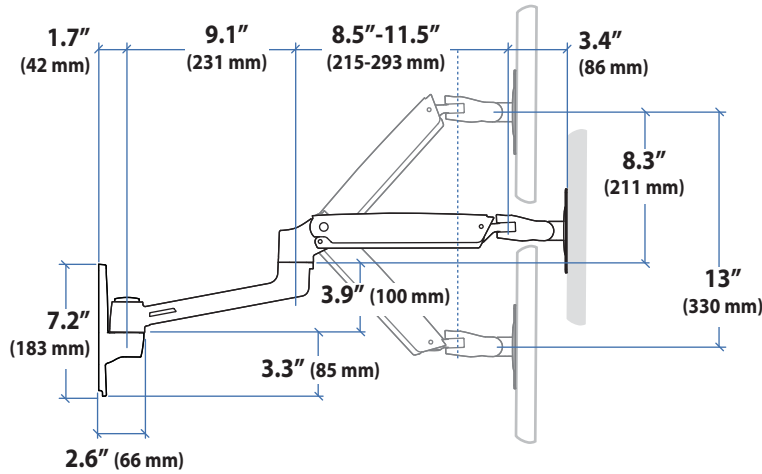

Wall Mount Bracket

Stud mounting:

M8 x 80mm or 5/16" x 3" and flat washer 8mm or 5/16" (2 places)

Wall Track mounting:

Button head cap screw #10-24 x 5/8" (4 places)

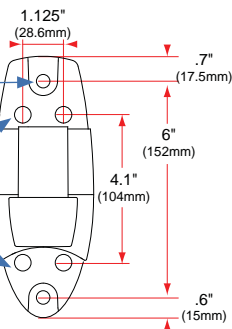

Range of Motion

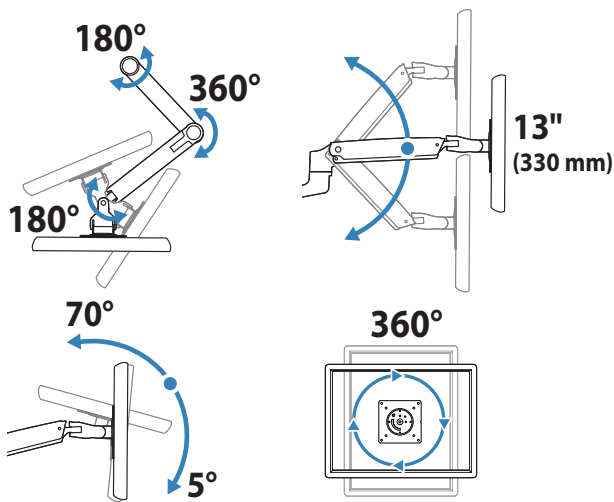

Weight Capacity

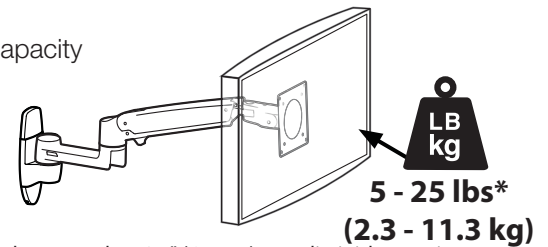

Monitor depth greater than 2.5" (64 mm) may diminish capacity. Call Ergotron for more information.

* The lower most range of motion for vertical lift is decreased up to 4.5" (114 mm) when arm is adjusted to hold over 20lbs (9 kgs).

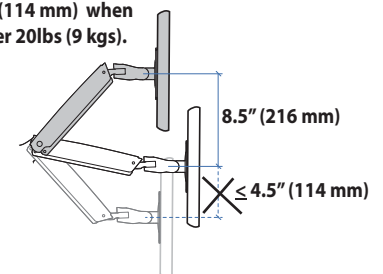

© 2014 Ergotron, Inc. rev. 07/17/2014 DIM-LXWM Content is subject to change without notification

Americas Sales and Corporate Headquarters

St. Paul, MN USA
(800) 888-8458
+1-651-681-7600
www.ergotron.com
sales@ergotron.com

EMEA Sales

Amersfoort, The Netherlands
+31 33 45 45 600
www.ergotron.com
info.eu@ergotron.com

APAC Sale

Tokyo, Japan
www.ergotron.com
apaccustomerservice@ergotron.com

Worldwide OEM Sales

www.ergotron.com
info.oem@ergotron.com

