

Dimensions

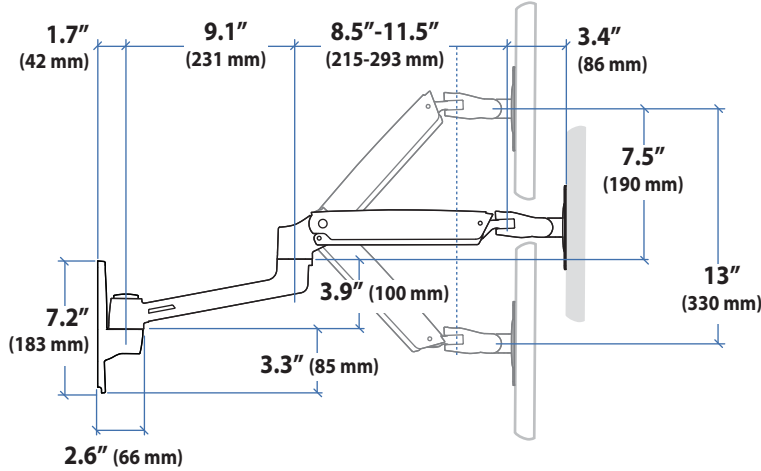

Wall Mount Bracket

Stud mounting:

M8 x 80mm or 5/16" x 3" and flat washer 8mm or 5/16" (2 places)

Wall Track mounting:

Button head cap screw #10-24 x 5/8" (4 places)

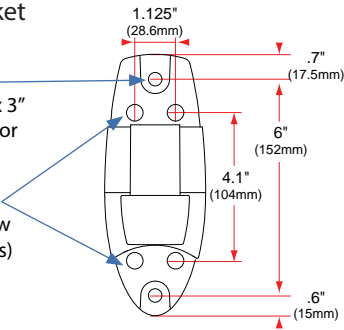

Range of Motion

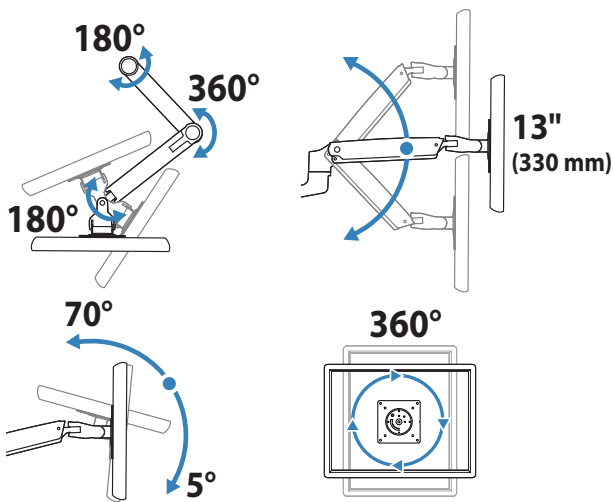

Weight Capacity

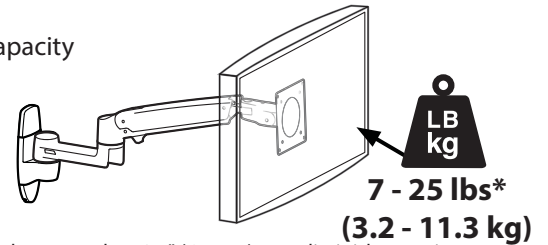

Monitor depth greater than 2.5" (64 mm) may diminish capacity. Call Ergotron for more information.

* The lower most range of motion for vertical lift is decreased up to 4.5" (114 mm) when arm is adjusted to hold over 20lbs (9 kgs).

