

# LX Desk Mount LCD Arm

## Touchboards

205 Westwood Ave, Long Branch, NJ 07740  
 Phone: 866-94 BOARDS (26273) / (732)-222-1511  
 Fax: (732)-222-7088 | E-mail: sales@touchboards.com

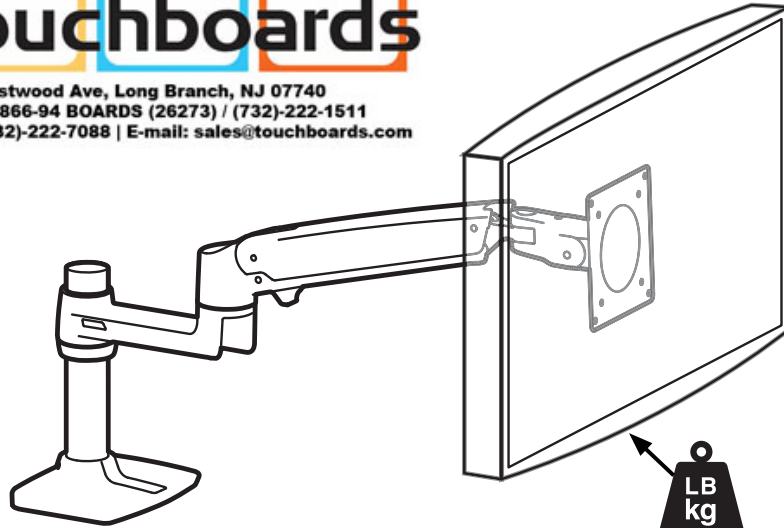

**7 - 25 lbs\***  
**(3.2 - 11.3 kg)**

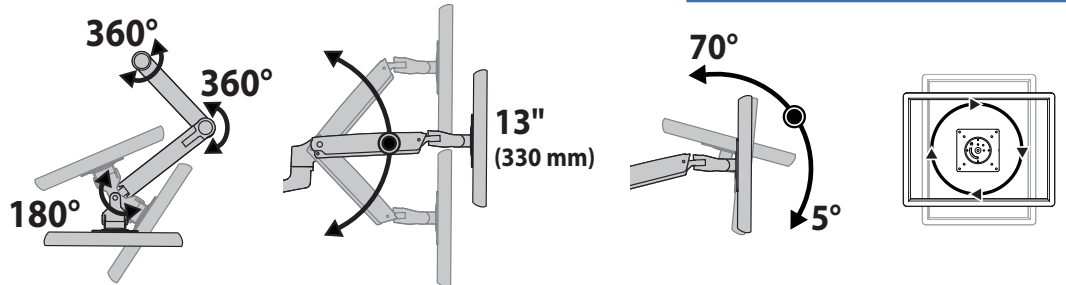
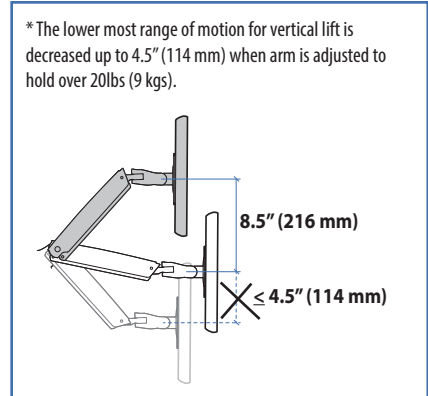

	A	B	C	D	E
1	  <b>1x</b>	<b>1x</b> 	<b>4x</b>  M4 x 10mm	<b>1x</b> 	<b>1x</b>  4mm
2			<b>4x</b>  M4 x 10mm		<b>1x</b>  2.5mm
3		<b>1x</b> 	<b>1x</b>  M3 x 6mm	<b>2x</b> 	

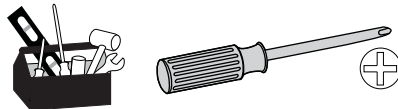

For the latest User Installation Guide please visit: [www.ergotron.com](http://www.ergotron.com)



User's Guide - English  
 Guía del usuario - Español  
 Manuel de l'utilisateur - Français  
 Gebrauchersgids - Deutsch  
 Benutzerhandbuch - Nederlands  
 Guida per l'utente - Italiano  
 Användarhandbok - svenska  
 ユーザーガイド : 日本語  
 用户指南 : 汉语



Includes  
 Constant Force™  
 Technology







[www.ergotron.com](http://www.ergotron.com)

USA 1-800-888-8458  
 Europe +31 (0)33-45 45 600  
 China 400-120-3051

# Hazard Symbols Review

These symbols alert users of a safety condition that demands attention. All users should be able to recognize and understand the significance of the following Safety Hazards if encountered on the product or within the documentation. Children who are not able to recognize and respond appropriately to Safety Alerts should not use this product without adult supervision!

Symbol	Signal Word	Level of Hazard
	<b>NOTE</b>	A NOTE indicates important information that helps you make better use of this product.
	<b>CAUTION</b>	A CAUTION indicates either potential damage to hardware or loss of data and tells you how to avoid the problem.
	<b>WARNING</b>	A WARNING indicates either potential for property damage, personal injury, or death.
	<b>ELECTRICAL</b>	An Electrical indicates an impending electrical hazard which, if not avoided, may result in personal injury, fire and/or death.

## Safety



Important! You will need to adjust this product after installation is complete. Make sure all your equipment is properly installed on the product before attempting adjustments. This product should move smoothly and easily through the full range of motion and stay where you set it. If movements are too easy or difficult or if product does not stay in desired positions, follow the adjustment instructions to create smooth and easy movements. Depending on your product and the adjustment, it may take many turns to notice a difference. Any time equipment is added or removed from this product, resulting in a change in the weight of the mounted load, you should repeat these adjustment steps to ensure safe and optimum operation.

 **Warning:** Because mounting surface materials can vary widely, it is imperative that you make sure mounting surface is strong enough to handle mounted product and equipment.

 **Caution:** To avoid the potential to pinch cables it is important to follow the cable routing instructions in this manual. Failure to follow these instructions may result in equipment damage or personal injury.

1

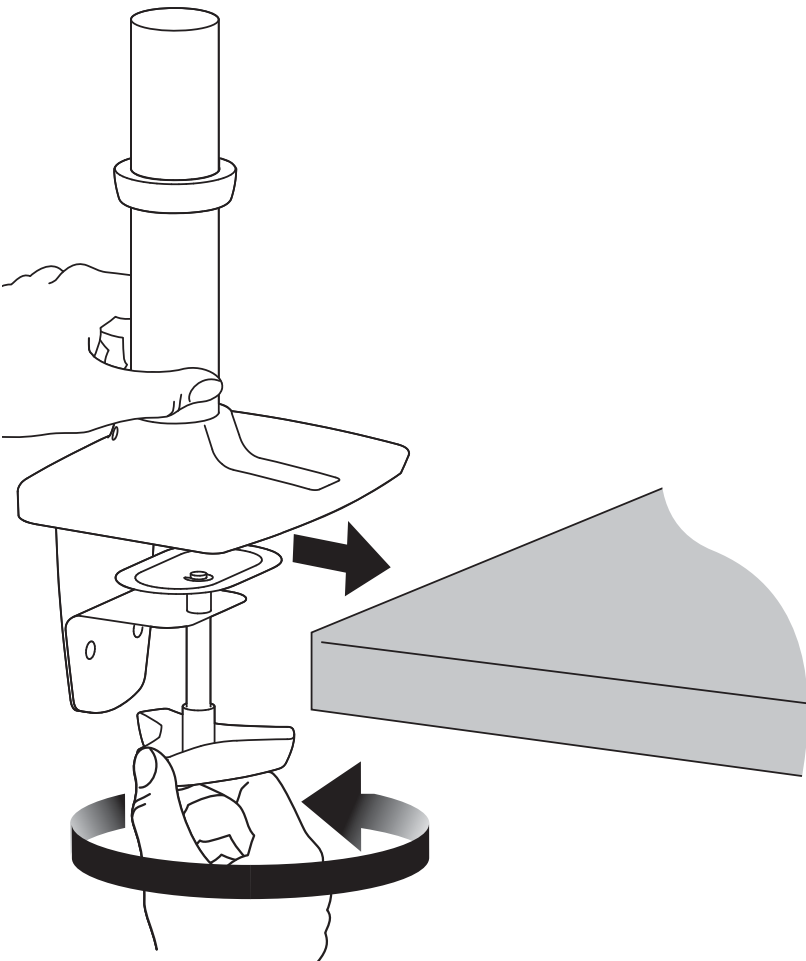
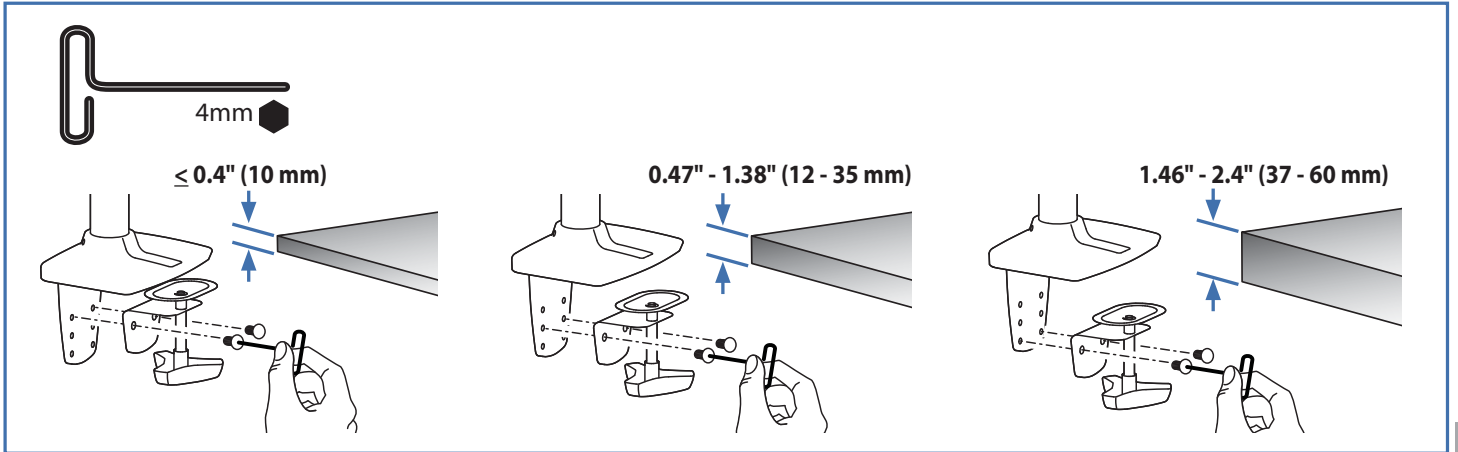
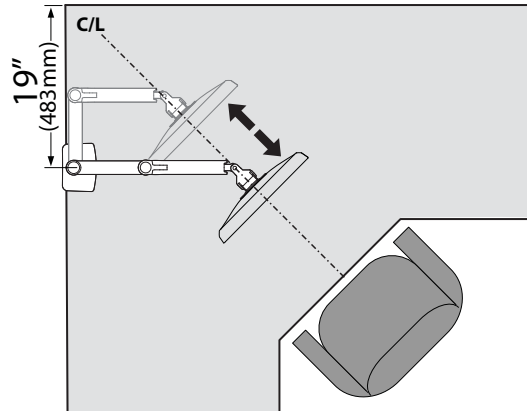
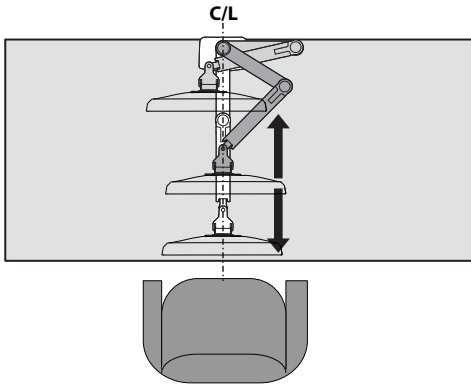

ENGLISH

2

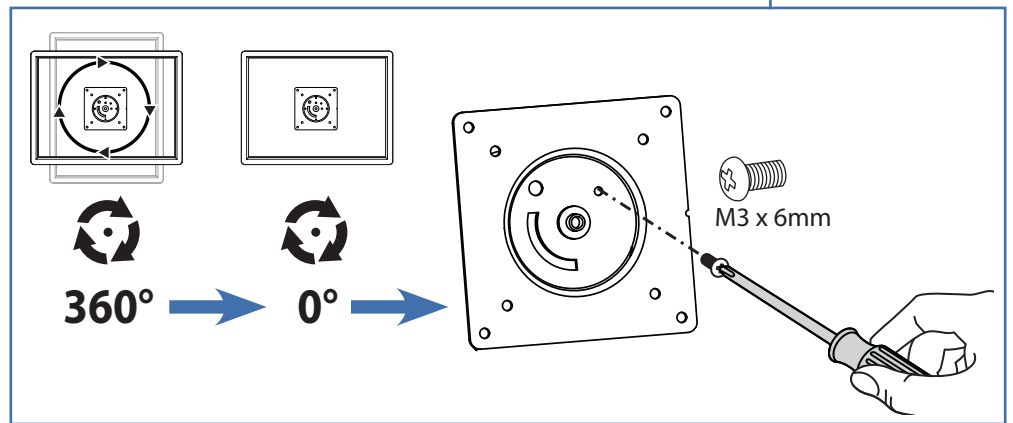
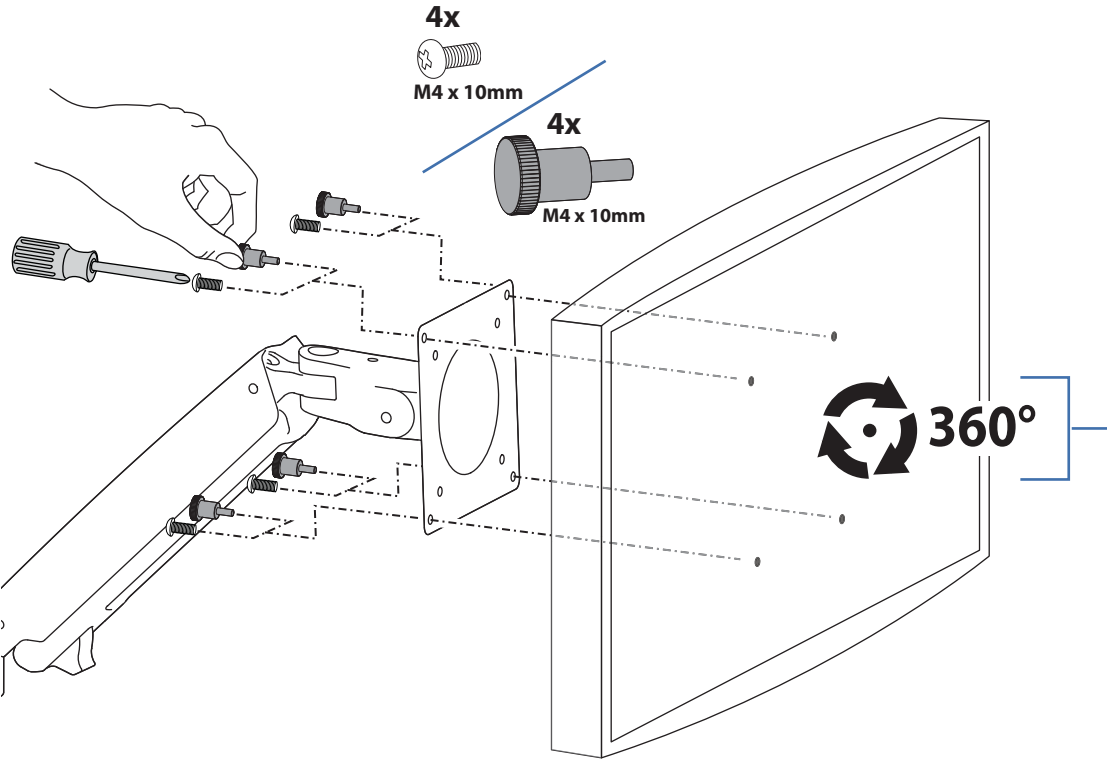

**WARNING! Stored Energy Hazard:** The arm mechanism is under tension and will move up rapidly, on its own, as soon as attached equipment is removed. For this reason, **DO NOT** remove equipment unless the arm has been moved to the highest position! Failure to follow this instruction may result in serious personal injury and/or equipment damage!

# Touchboards

205 Westwood Ave, Long Branch, NJ 07740  
 Phone: 866-94 BOARDS (26273) / (732)-222-1511  
 Fax: (732)-222-7088 | E-mail: sales@touchboards.com

3

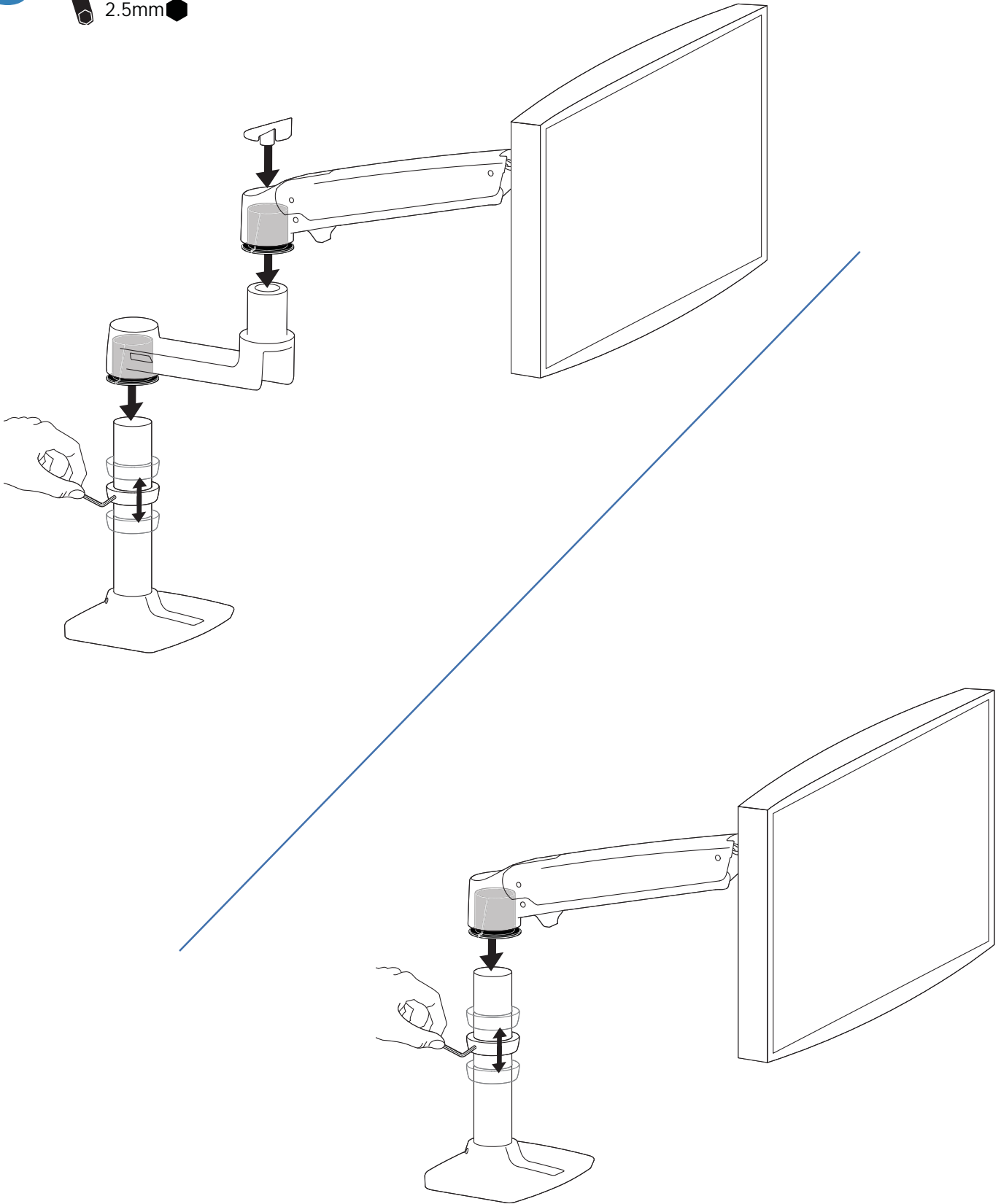

ENGLISH

4



**NOTE:** Leave enough slack in cable to allow full range of motion.



**Caution:** To avoid the potential to pinch cables it is important to follow the cable routing instructions in this manual. Failure to follow these instructions may result in equipment damage or personal injury.

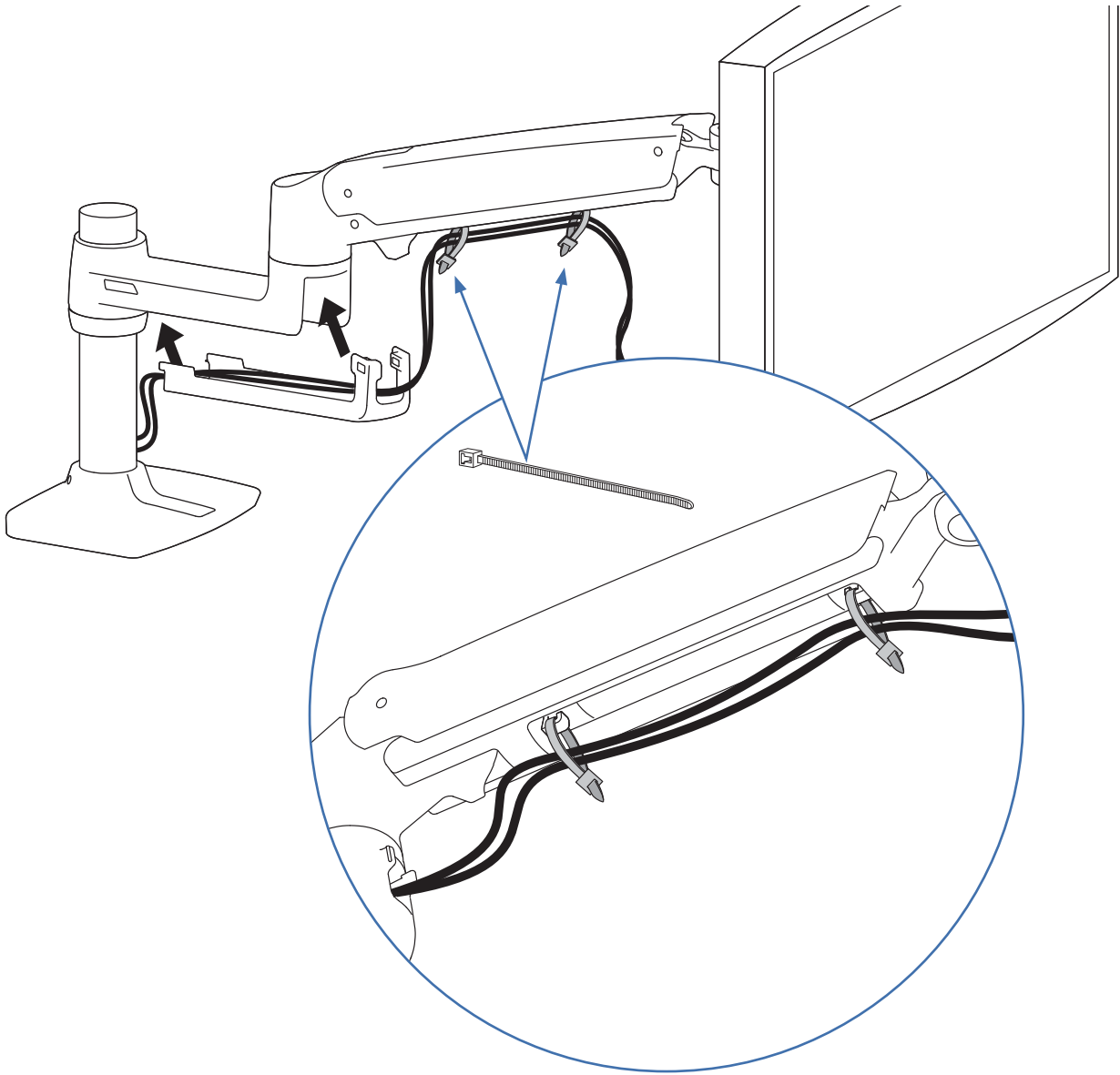

ENGLISH

5

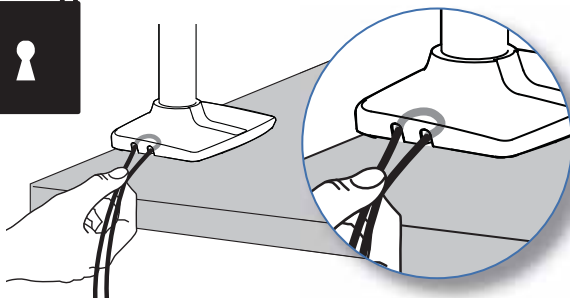

# 6 Lift – Up and down

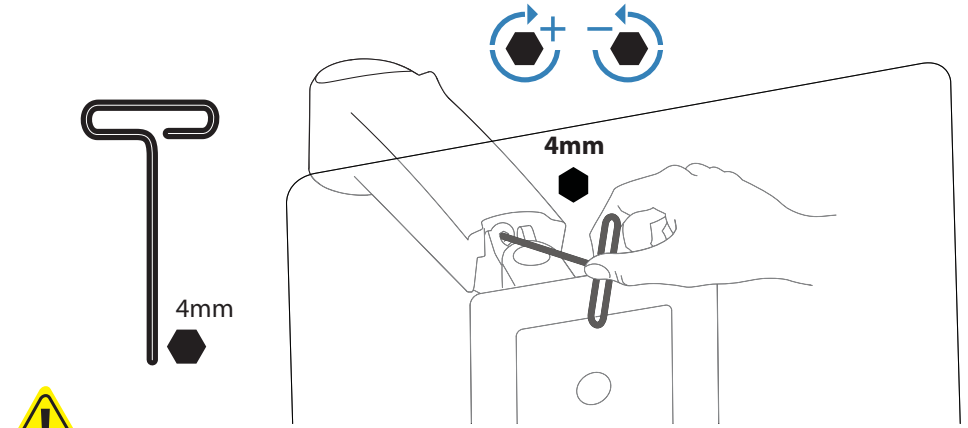
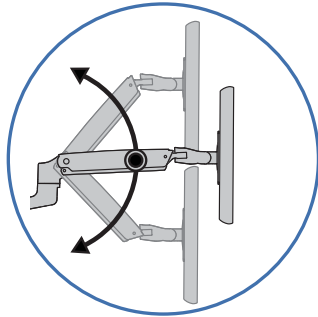

**CAUTION: DO NOT** overtighten fasteners. Overtightening may cause damage to your equipment.



### Increase Lift Strength

If the mounted weight is too heavy or this product does not stay up when raised, then you'll need to increase Lift Strength:



### Decrease Lift Strength

If the mounted weight is too light or this product does not stay down when lowered, then you'll need to decrease Lift Strength:



# b Tilt – Forward and Backward

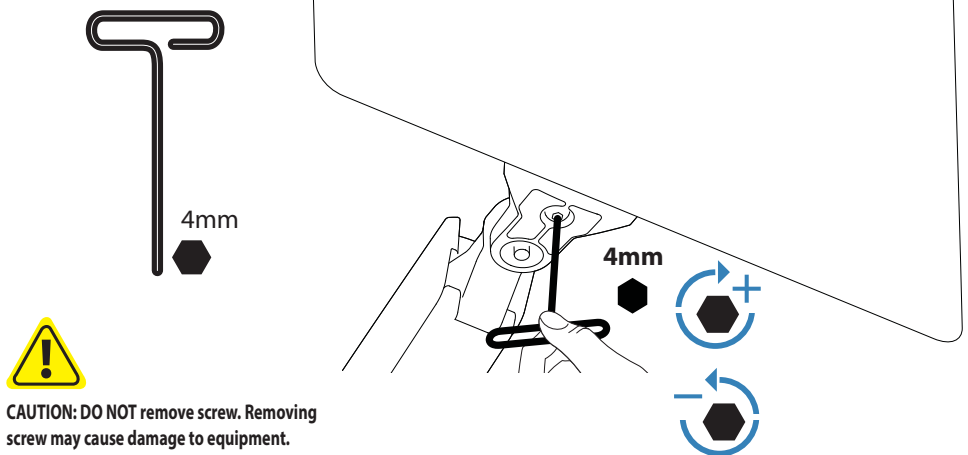
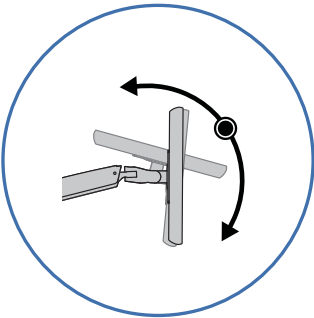

**CAUTION: DO NOT** remove screw. Removing screw may cause damage to equipment.



### Increase Friction

If this product moves too easily, then you'll need to increase friction:





### Decrease Friction

If this product is too difficult to move, then you'll need to decrease friction:

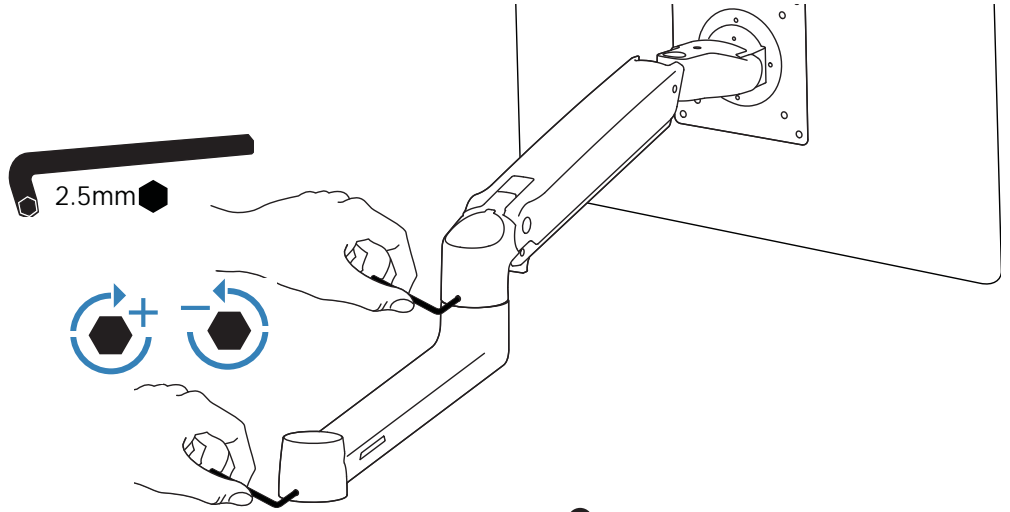
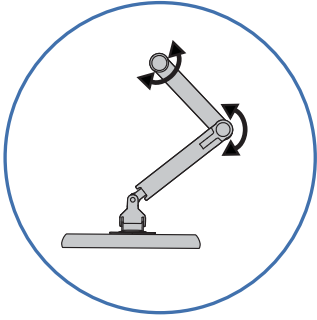

### C Arm Swing - Side-to-side



**+**  **Increase Friction**  
If this product moves too easily, then you'll need to increase friction:

**-**  **Decrease Friction**  
If this product is too difficult to move, then you'll need to decrease friction:



### d Rotate - Portrait/Landscape

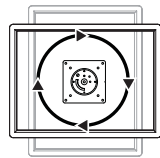

360°

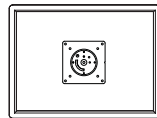

0°

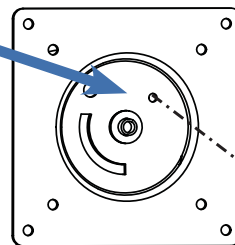

  
M3 x 6mm

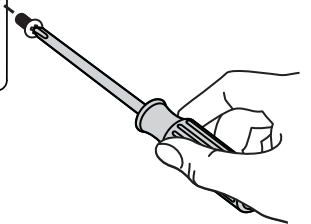



Set Your Workstation to Work For YOU!

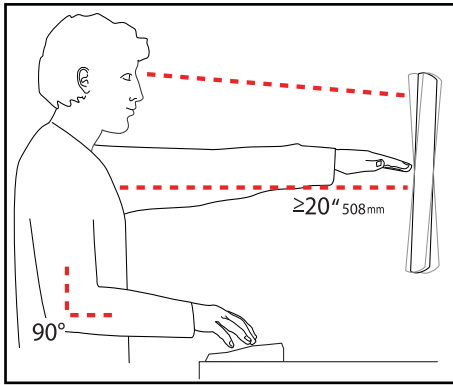

Learn more about ergonomic computer use at:  
[www.computingcomfort.org](http://www.computingcomfort.org)

- Height** Position top of screen slightly below eye level.  
Position keyboard at about elbow height with wrists flat.
- Distance** Position screen an arm's length from face—at least 20" (508mm).  
Position keyboard close enough to create a 90° angle in elbow.
- Angle** Tilt screen to eliminate glare.  
Tilt the keyboard back 10° so that your wrists remain flat.

- To Reduce Fatigue  
Breathe - Breathe deeply through your nose.  
Blink - Blink often to avoid dry eyes.  
Break • 2 to 3 minutes every 20 minutes  
• 15 to 20 minutes every 2 hours.

For Warranty visit: [www.ergotron.com/warranty](http://www.ergotron.com/warranty)

For Service visit: [www.ergotron.com](http://www.ergotron.com)

For local customer care phone numbers visit: <http://contact.ergotron.com>

# Touchboards

205 Westwood Ave, Long Branch, NJ 07740

Phone: 866-94 BOARDS (26273) / (732)-222-1511

Fax: (732)-222-7088 | E-mail: [sales@touchboards.com](mailto:sales@touchboards.com)

**Americas Sales and  
Corporate Headquarters**

1181 Trapp Rd.  
St. Paul, MN USA  
(800) 888-8458  
+1-651-681-7600  
[www.ergotron.com](http://www.ergotron.com)  
[sales@ergotron.com](mailto:sales@ergotron.com)

**EMEA Sales**

Amersfoort, The Netherlands  
+31 33 45 45 600  
[www.ergotron.com](http://www.ergotron.com)  
[info.eu@ergotron.com](mailto:info.eu@ergotron.com)

**APAC Sales**

Tokyo, Japan  
[www.ergotron.com](http://www.ergotron.com)  
[apaccustomerservice@ergotron.com](mailto:apaccustomerservice@ergotron.com)

**Worldwide OEM Sales**

[www.ergotron.com](http://www.ergotron.com)  
[info.oem@ergotron.com](mailto:info.oem@ergotron.com)

**ERGOTRON®**

While Ergotron, Inc. makes every effort to provide accurate and complete information on the installation and use of its products, it will not be held liable for any editorial errors or omissions (including those made in the process of translation from English to another language), or for incidental, special or consequential damages of any nature resulting from furnishing this instruction and performance of equipment in connection with this instruction. Ergotron, Inc. reserves the right to make changes in the product design and/or product documentation without notification to its users. For the most current product information, or to know if this document is available in languages other than those herein, please contact Ergotron. No part of this publication may be reproduced, stored in a retrieval system, or transmitted in any form or by any means, electronic, mechanical, photocopying, recording or otherwise without the prior written consent of Ergotron, Inc., 1181 Trapp Road, Eagan, Minnesota, 55121, USA. Patents Pending and Patented U.S. & Foreign. Ergotron is a registered trademark of Ergotron, Inc.

© 2015 Ergotron, Inc. All rights reserved.