

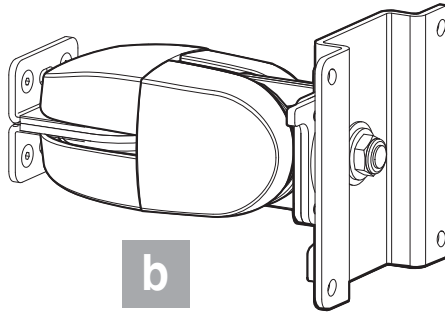

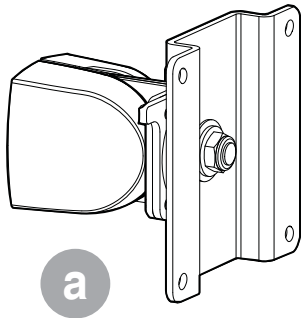

100 Series Flat Panel Monitor Pivots Vertical Surface, Direct Mount

www.ergotron.com
 USA 1-800-888-8458
 Europe +31 (0)33-45 45 600
 China 86-769-86018920

Touchboards

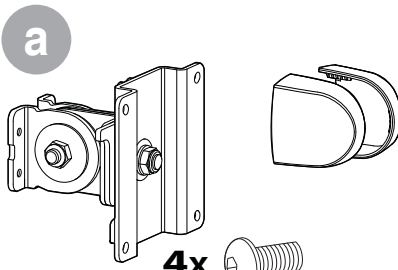
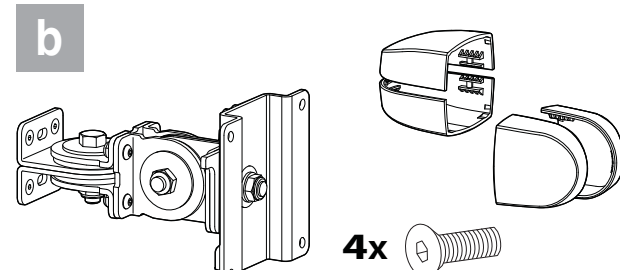
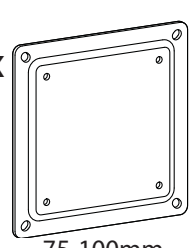
205 Westwood Ave, Long Branch, NJ 07740
 Phone: 866-94 BOARDS (26273) / (732)-222-1511
 Fax: (732)-222-7088 | E-mail: sales@touchboards.com

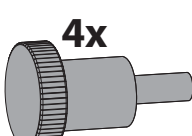

	A	B
1	 <p>4x #8-32 x 5/16"</p>	 <p>4x #8-32 x 3/8"</p>
2	 <p>1x 75-100mm</p>  <p>4x #8-32</p>  <p>4x M4 x 10mm</p>  <p>4x M4 x 10mm</p>  <p>1x 3/32"</p>	

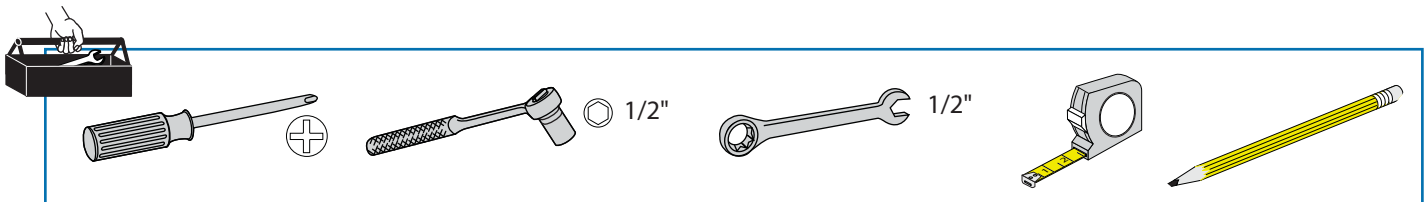

1 Determine Ergonomic Mounting Height

Set Your Workstation to Work For YOU!

- Height** Position top of screen slightly below eye level.
Position keyboard at about elbow height with wrists flat.
- Distance** Position screen an arm's length from face—at least 20" (508mm).
Position keyboard close enough to create a 90° angle in elbow.
- Angle** Tilt screen to eliminate glare.
Tilt the keyboard back 10° so that your wrists remain flat.

To Reduce Fatigue

- Breathe - Breathe deeply through your nose.
- Blink - Blink often to avoid dry eyes.
- Break • 2 to 3 minutes every 20 minutes
- 15 to 20 minutes every 2 hours.

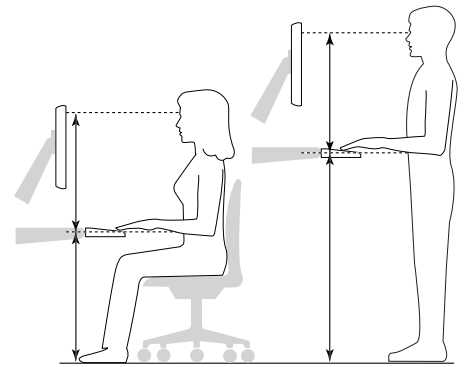

Learn more about ergonomic computer use at:
www.computingcomfort.org

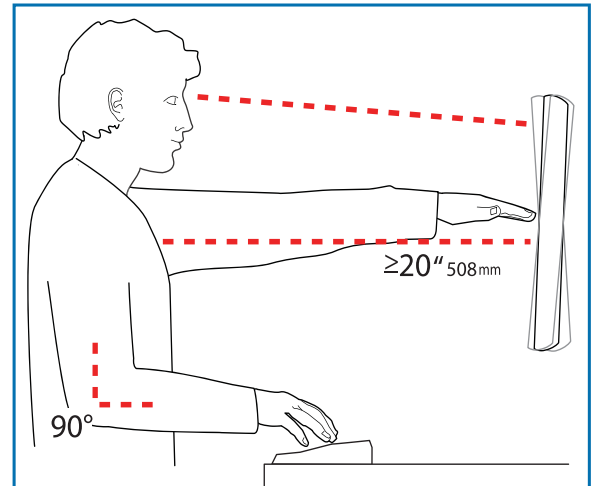

2 Determine Mounting Configuration



WARNING

Because surfaces vary widely and the ultimate mounting method is out of Ergotron's control, it is imperative that you consult with appropriate engineering, architectural or construction professional to ensure that your Ergotron mounting solution is mounted properly to handle applied loads.

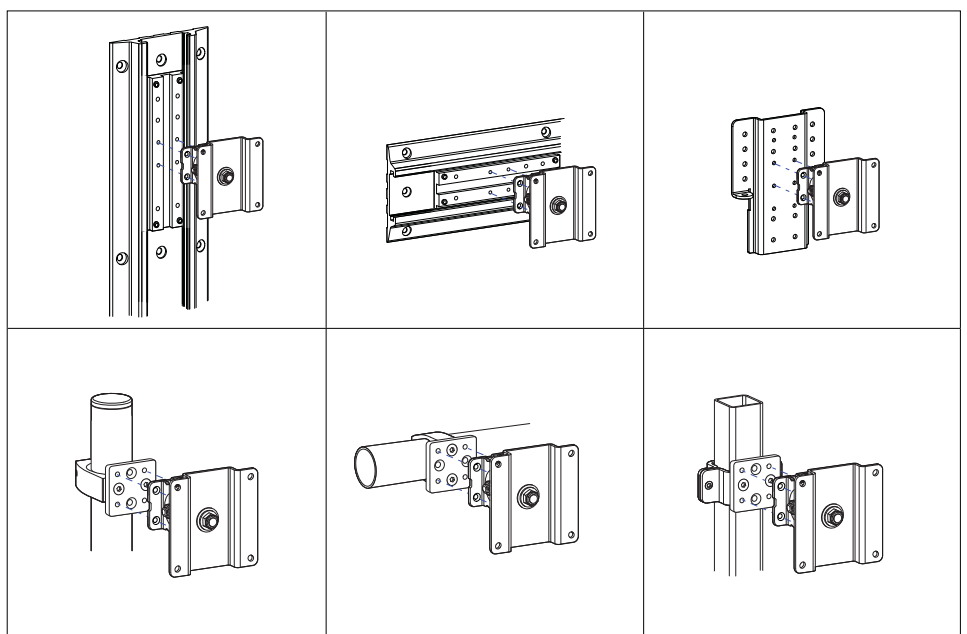
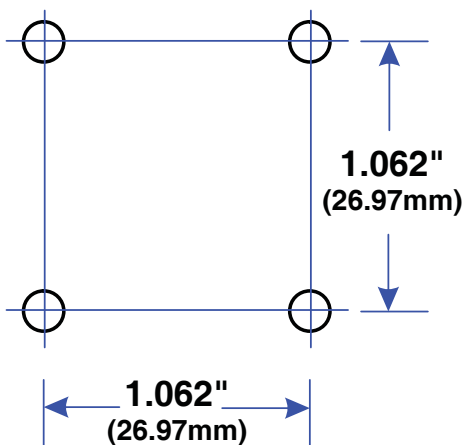

NOTE: Fasteners may unwind due to vibration caused by movement of mounting solution over time. Inspect mounting solution for loose fasteners on a routine basis. If desired, apply a light duty thread locking adhesive to fasteners before installation to prevent back-out.

3 Mount Pivot

a 4x #8-32 x 5/16"

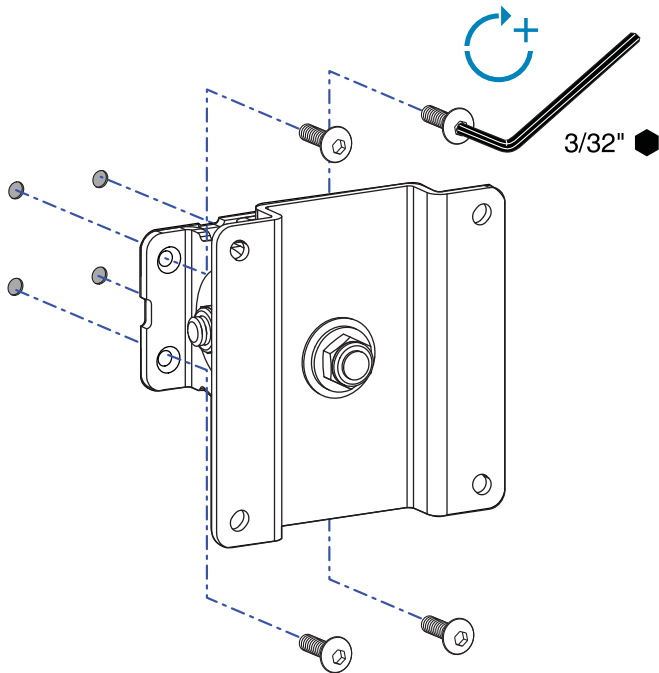

b 4x #8-32 x 3/8"

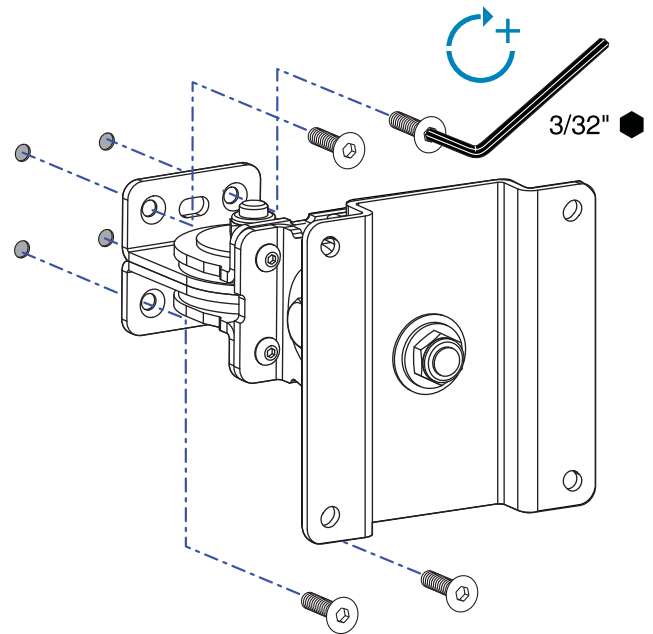

4 Attach Monitor

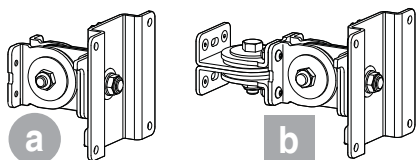

c
75 mm

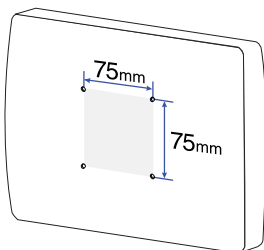

d
100 mm

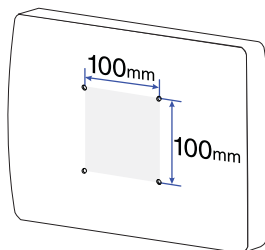

X mm

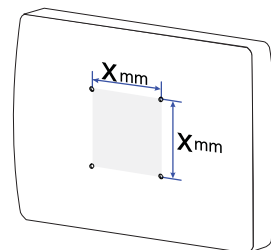

www.ergotron.com
USA 1-800-888-8458
Europe +31 (0)33-45 45 600
China 86-769-86018920



If your monitor uses a screw size other than M4 x 10mm, DO NOT use the M4 x 10mm screws or knob provided as they could result in damage to the monitor.

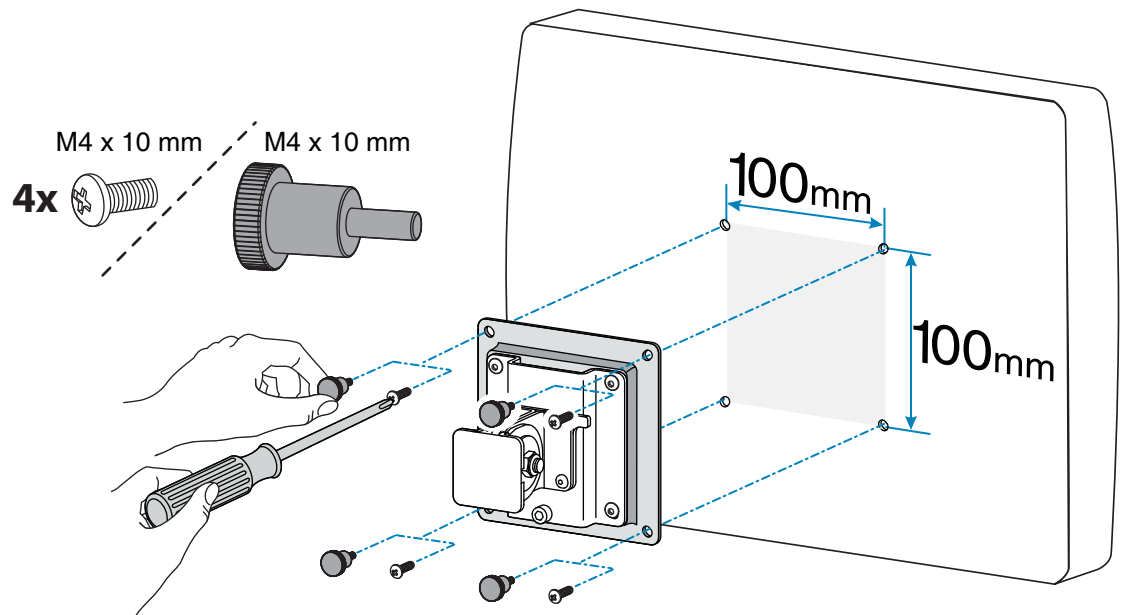
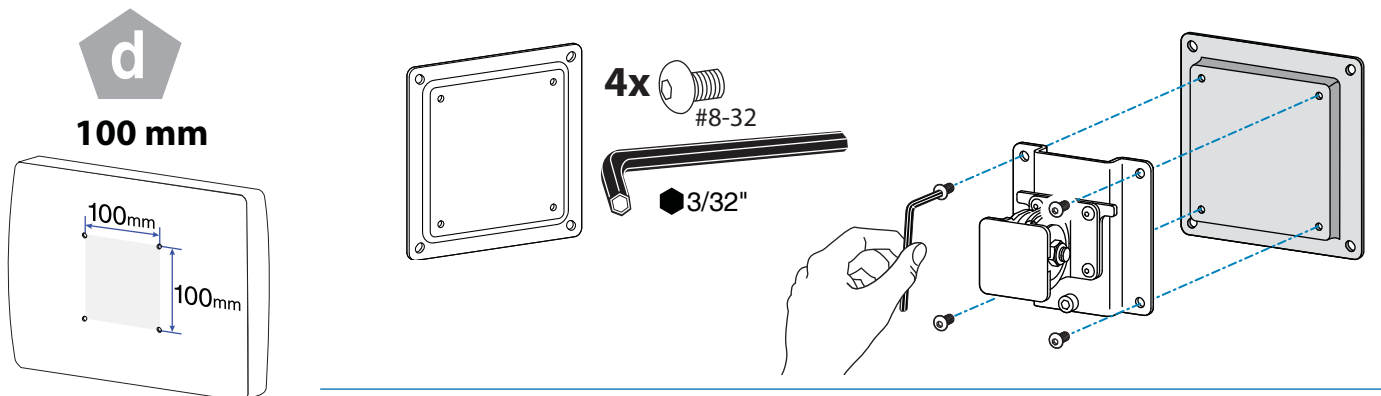
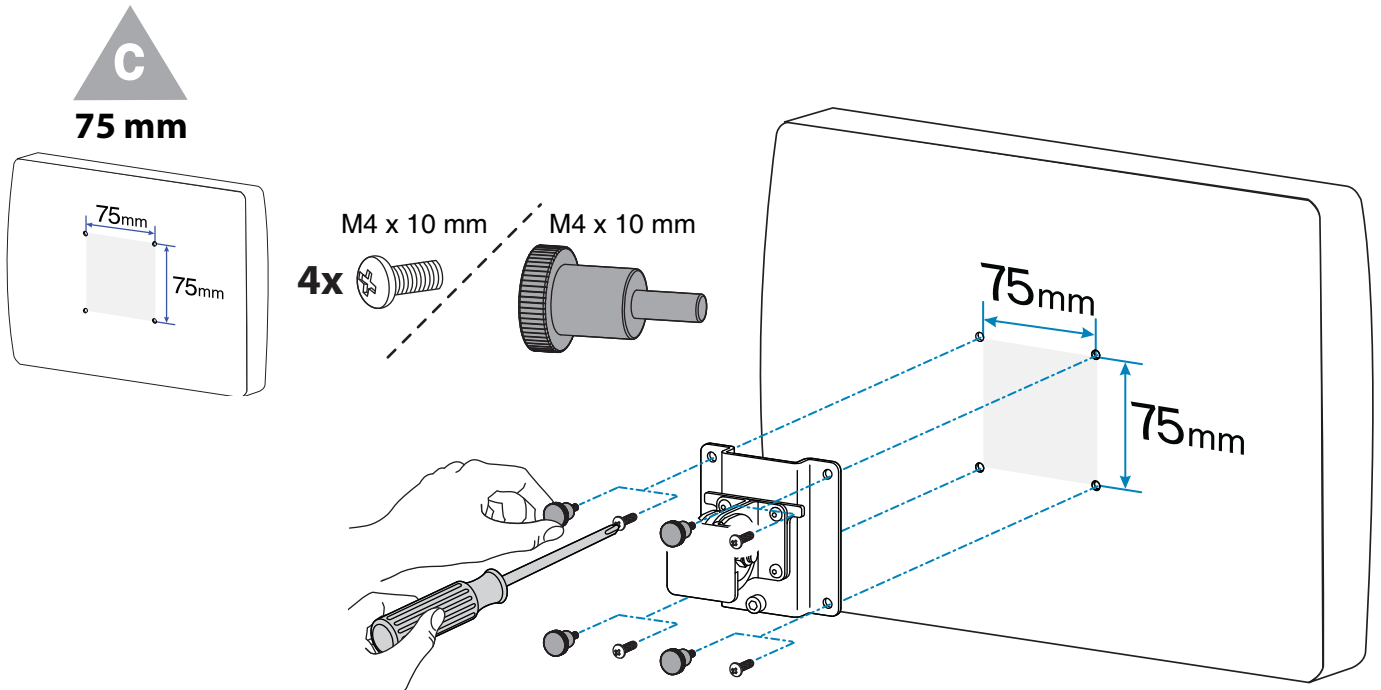

5 Tilt Motion

Tilt monitor up and down through entire pivot range of motion. If it does not stay in place or movement in one direction is stiff, pivot needs adjustment - see below. Adjust until monitor stays in place and tilting forces, up or down, are equal.

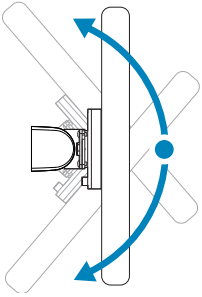

Adjust Tilt

To Increase Tension: Turn screw clockwise.

To Decrease Tension: Turn screw counterclockwise.

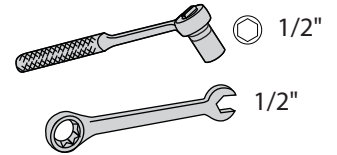
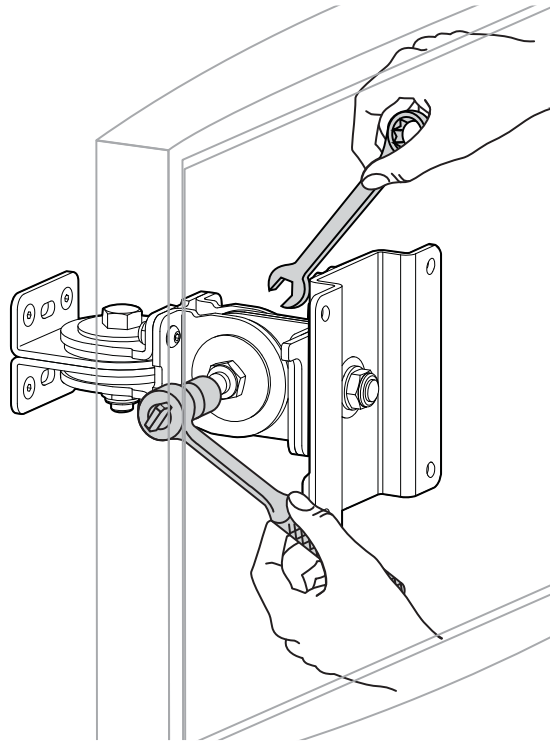

6 Side-to-Side Motion

Move monitor side-to-side through entire range of motion. If it does not stay in place at any point it will need adjustment - see below. Adjust so side-to-side moving forces are equal.

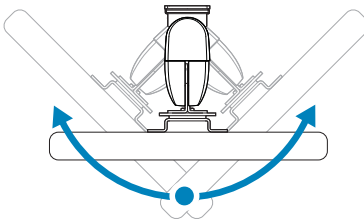

Adjust Side-to-Side

To Increase Tension: Turn screw clockwise.

To Decrease Tension: Turn screw counterclockwise.

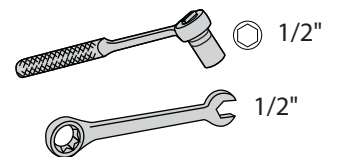
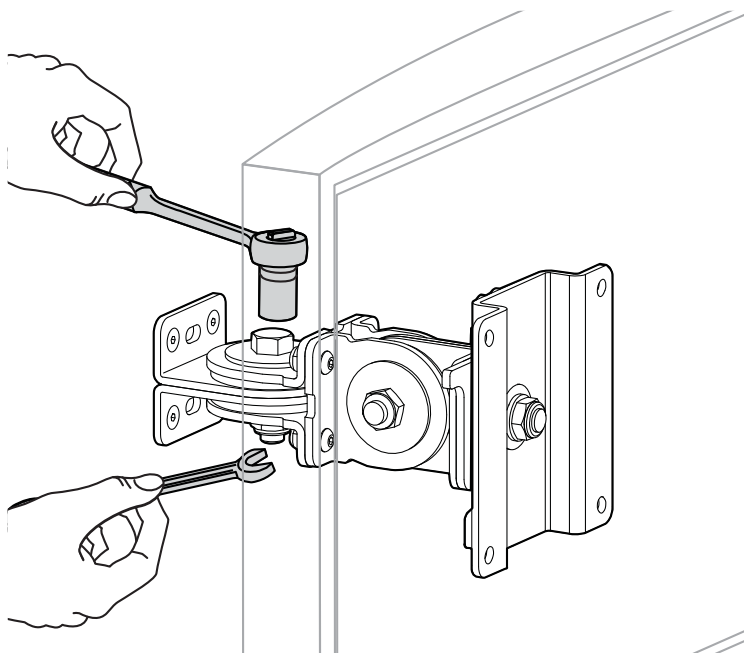

7

Portrait/Landscape

Rotate monitor from Portrait to Landscape through entire range of motion. If it does not stay in place or movement in one direction is stiff, tension needs adjustment - see below. Adjust until monitor stays in place and tension, portrait to landscape, is equal.

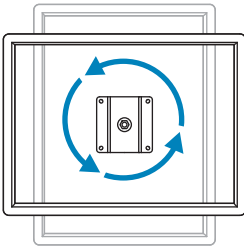

Adjust Portrait/Landscape

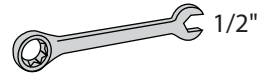

To Increase Tension: Turn screw clockwise.

To Decrease Tension: Turn screw counterclockwise.

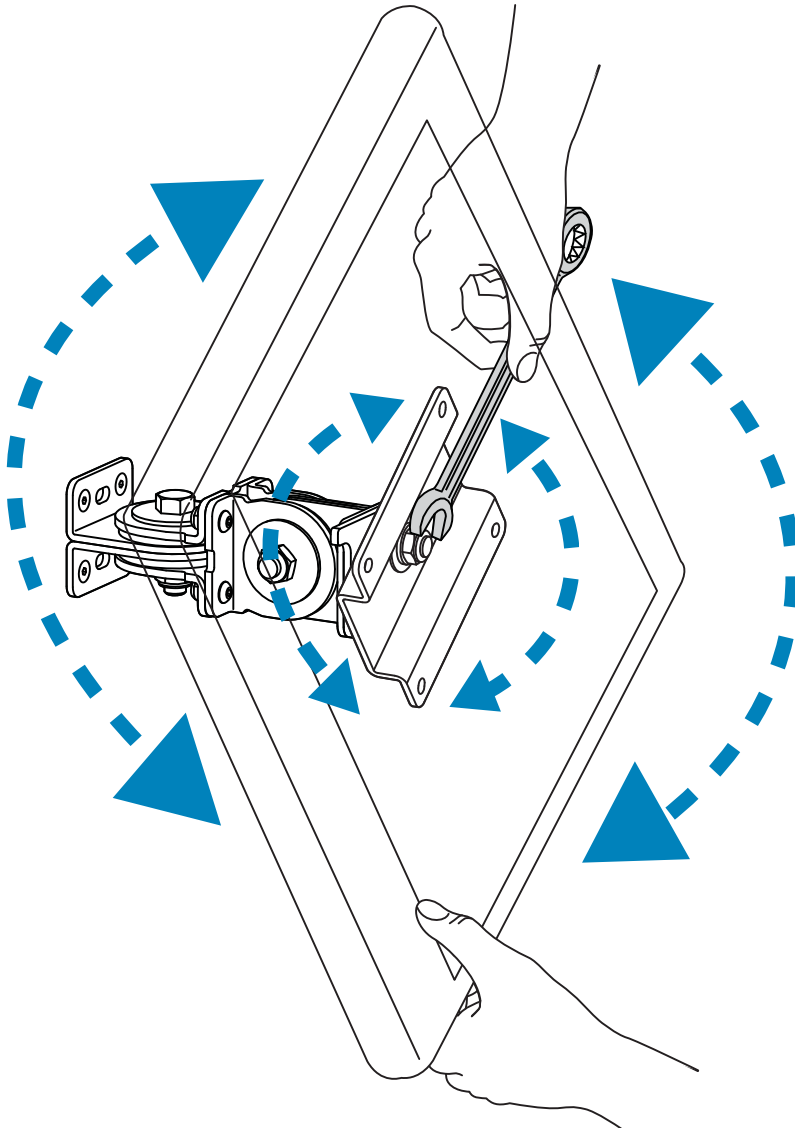



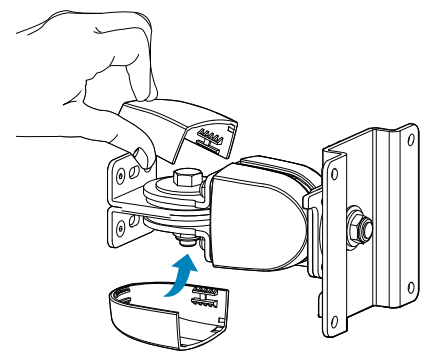
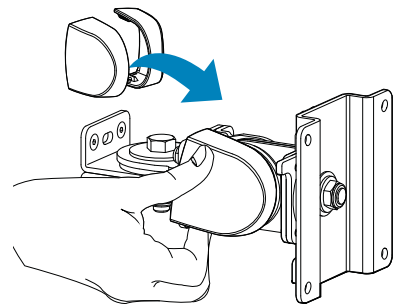
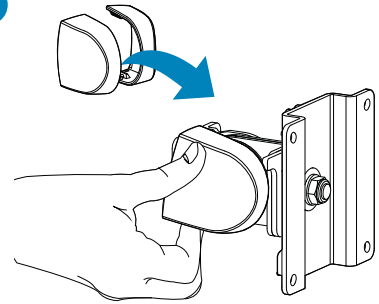

8

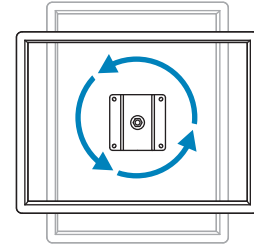
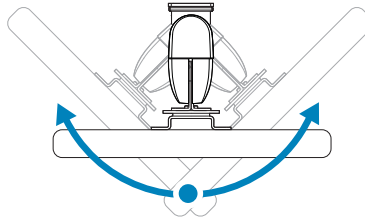
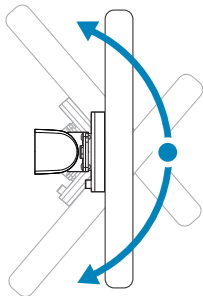

? Troubleshooting



Symptom	Probable Cause	Solution
Monitor tilts up and down too easily or with difficulty.	Pivot Tension needs adjustment.	8 Tilt Motion 
	Monitor exceeds weight capacity*.	 www.ergotron.com USA 1-800-888-8458 Europe +31 (0)33-45 45 600  China 86-769-86018920
Monitor moves side-to-side too easily or with difficulty.	Pivot Tension needs adjustment.	9 Side-to-Side Motion 
Monitor rotates from portrait to landscape too easily or with difficulty.	Pivot Tension needs adjustment.	10 Portrait/Landscape 

* Weight Capacities:

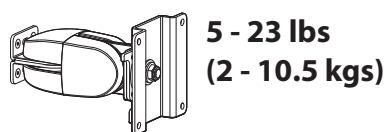
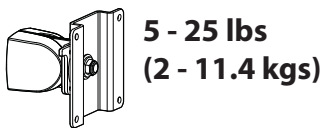

205 Westwood Ave, Long Branch, NJ 07740
 Phone: 866-94 BOARDS (26273) / (732)-222-1511
 Fax: (732)-222-7088 | E-mail: sales@touchboards.com

