



INSTALLATION INSTRUCTIONS

Slat Wall Clamp System

Made in the U.S.A.

Read these instructions first and follow all steps in sequence.

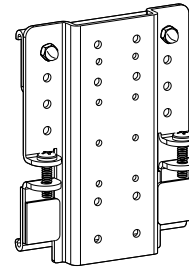

COMPONENTS

- A Upper Clamp
- B Lower Clamp
- C Slat Wall Bracket

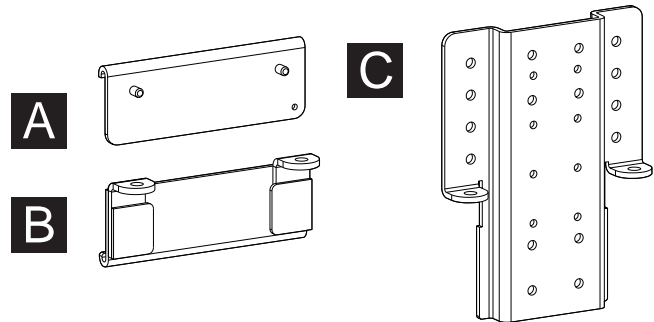

NOTE: Illustrations depict typical product. Yours may vary slightly.

FASTENERS

- a #10-24 Acorn Nut
- b 1/4-20 x 1" Phillips Pan Head Screw

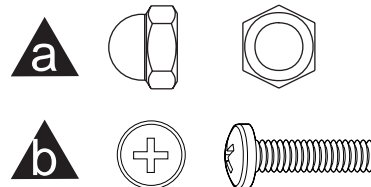

TOOLS REQUIRED

3/8" Open end wrench (customer supplied)

Hang Upper Clamp to edge of Slat Wall.

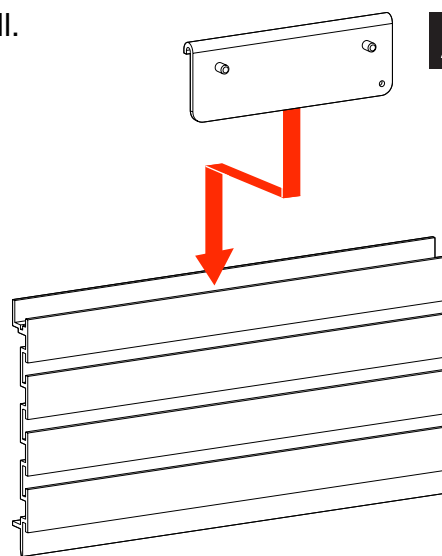

STEP
1



205 Westwood Ave, Long Branch, NJ 07740
Phone: 866-94 BOARDS (26273) / (732)-222-1511
Fax: (732)-222-7088 | E-mail: sales@touchboards.com

Slide Slat Wall Bracket onto Lower Clamp.

STEP
2

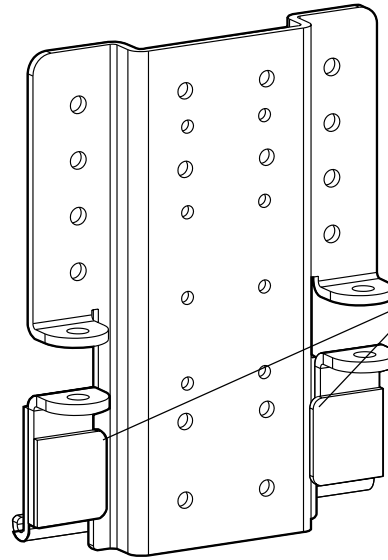
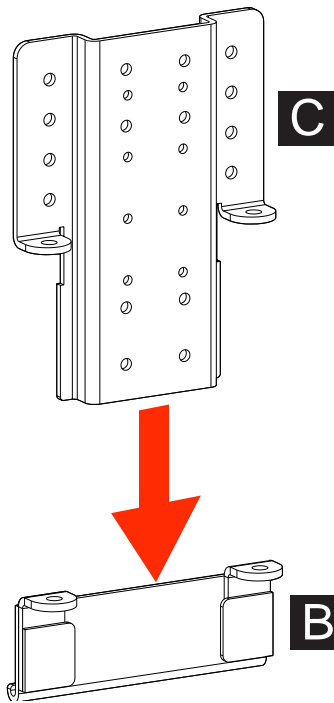

NOTE:
Wall Bracket slides
beneath tabs of
Lower Clamp.

Mount Slat Wall Bracket/Lower Clamp
assembly to Upper Clamp.



STEP
3

Thread Acorn Nuts onto Upper Clamp pins.

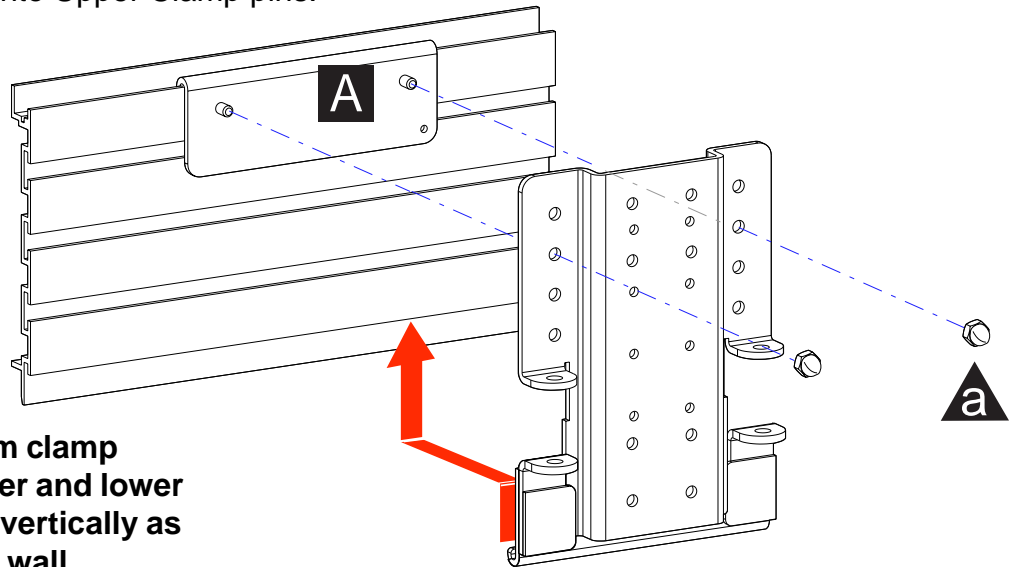

NOTE: For maximum clamp
strength, place upper and lower
clamps as far apart vertically as
possible on the slat wall .

Using a 3/8" wrench, tighten Acorn Nuts.

STEP
4

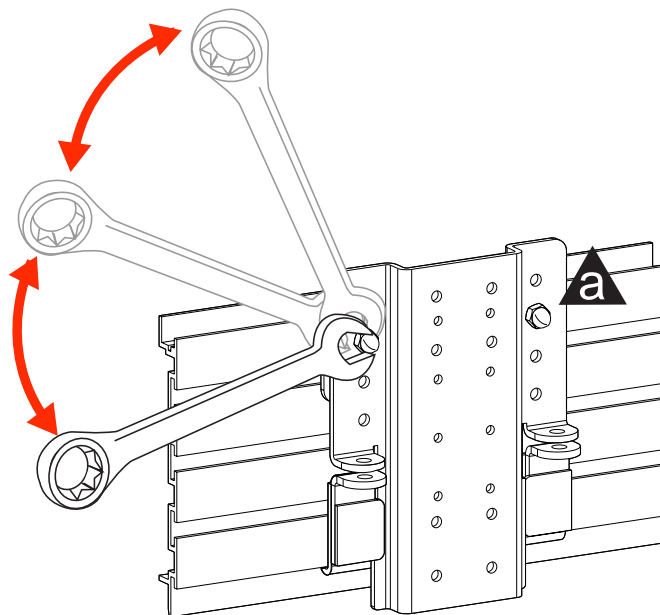

Using a Phillips screwdriver with provided screws, secure Slat Wall Bracket to Lower Clamp.



STEP
5

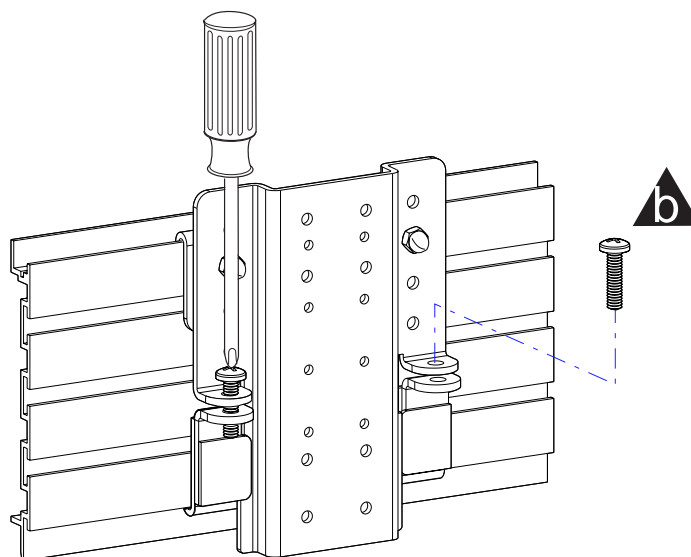

Mounting Patterns



205 Westwood Ave, Long Branch, NJ 07740
 Phone: 866-94 BOARDS (26273) / (732)-222-1511
 Fax: (732)-222-7088 | E-mail: sales@touchboards.com

- A** 100 Series Direct Mount Pivot
- B** 200 Series Vertical Mount Bracket
- C** 400 Series Flat Panel Monitor Arm with Fixed Mount
- D** 400 Series Flat Panel Monitor Arm with Rotate Mount

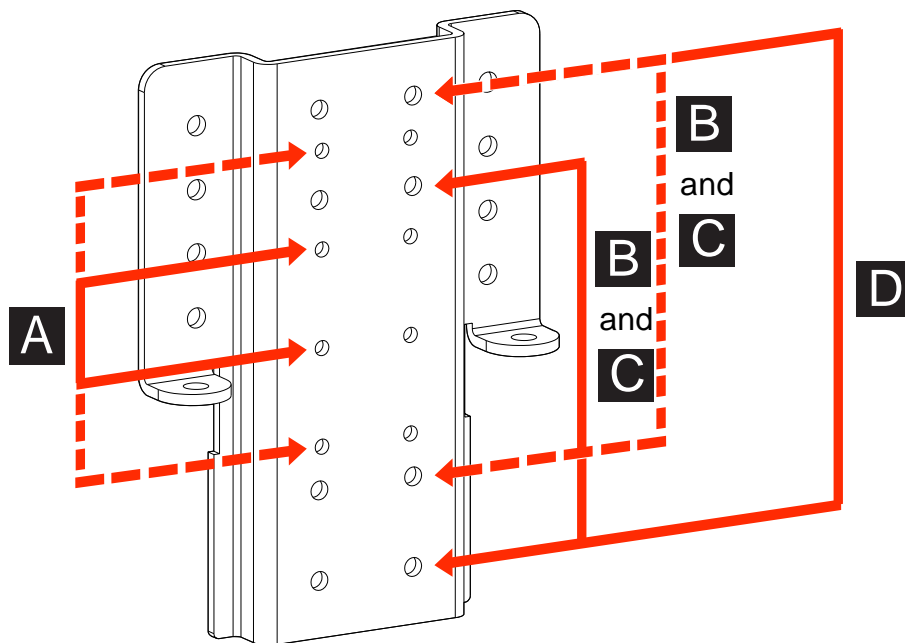

Replacement Parts

| Part Number | Description |
|-------------|------------------------|
| 696-569 | Mounting Hardware Kit* |

* Kit Includes: two #10-24 Acorn Nuts and two 1/4-20 x 1" Phillips Pan Head Screws



1181 Trapp Road • St. Paul, MN 55121
 800-383-1916 • in MN: 651-681-7600
 Fax: 651-681-7717 • www.ergotron.com

Patents Pending & Patented U.S. & Foreign.
 Ergotron is a registered trademark of Ergotron, Inc.
 Reproduction of this material in whole or part for any purpose other than that authorized by Ergotron, Inc. is prohibited.

© 2000 Ergotron Inc. All rights reserved.