

GLIDE VHD

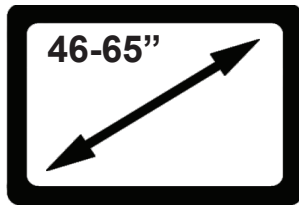

This product is intended to be mounted on a wood stud wall or a solid concrete wall. A wood stud wall is defined as consisting of a minimum of 2x4 wooden studs (2" wide by 4" deep) with a maximum of 5/8" drywall.

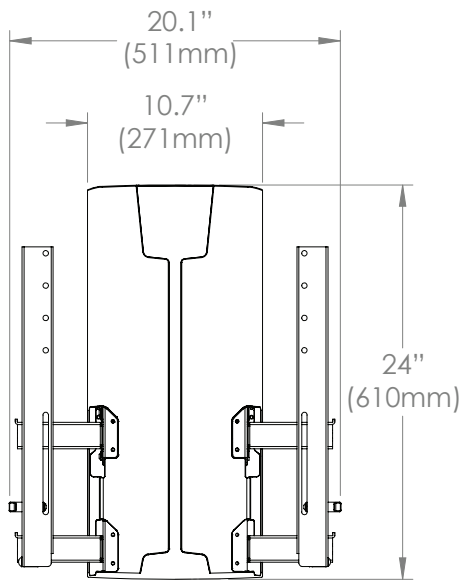

FRONT VIEW

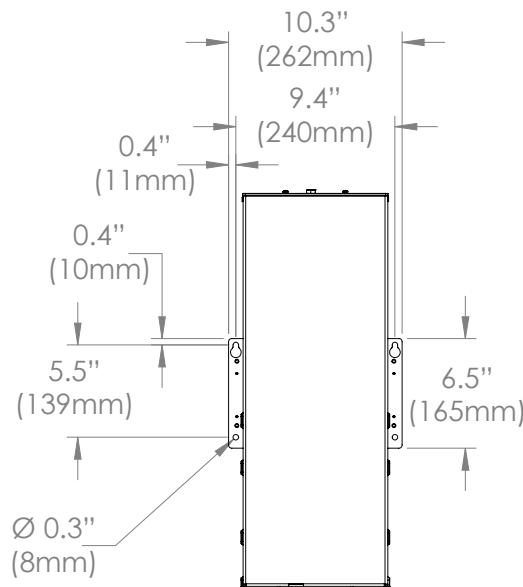

WALL MOUNTING

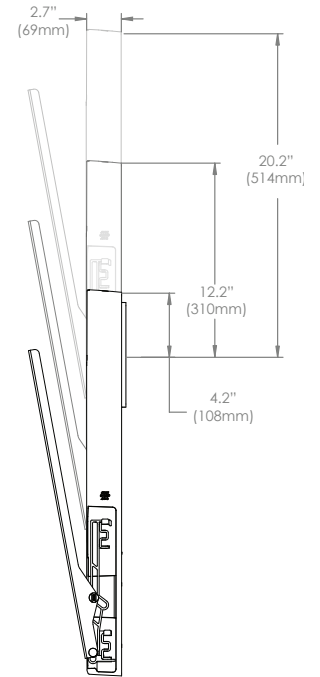

VERTICAL LIFT
Centered Wall Plate

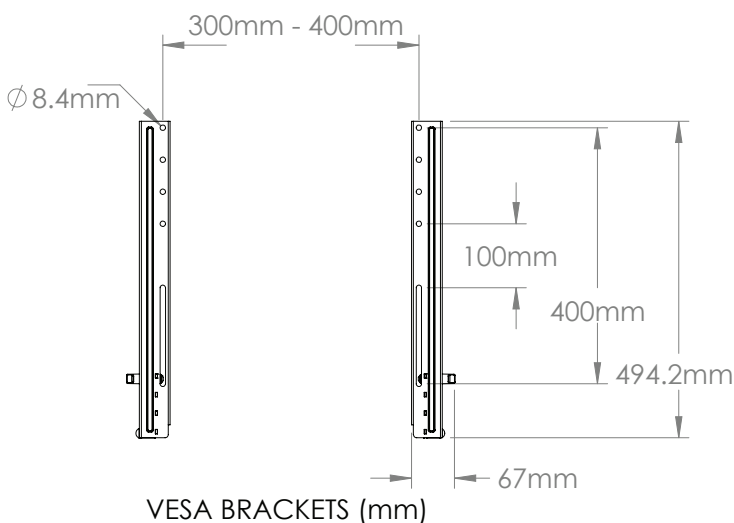

VESA BRACKETS (mm)

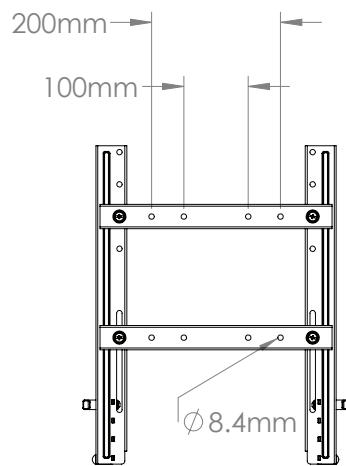

VESA BRACKETS (mm)
WITH ADAPTERS

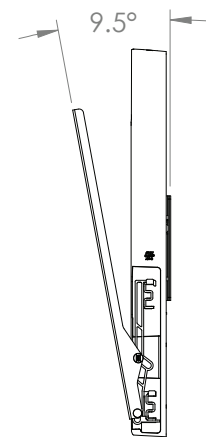

TILT RANGE

© 2013 Ergotron, Inc. rev. 06/26/13 DIM-GlideVHD Content is subject to change without notification

Americas Sales and Corporate Headquarters

St. Paul, MN USA
(800) 888-8458
+1-651-681-7600
www.ergotron.com
sales@ergotron.com

EMEA Sales

Amersfoort, The Netherlands
+31 33 45 45 600
www.ergotron.com
info.eu@ergotron.com

APAC Sales

Tokyo, Japan
www.ergotron.com
apaccustomerservice@ergotron.com

Worldwide OEM Sales

www.ergotron.com
info.oem@ergotron.com

