

Auto Retractable Keyboard Assembly

for use with Ergotron products:

25-022

60-593



CAUTION:

Product is shipped with a stop screw that **MUST** be removed before use. **DO NOT REMOVE STOP SCREW BEFORE ATTACHING KEYBOARD TRAY.** Failure to follow these instructions will cause equipment damage.

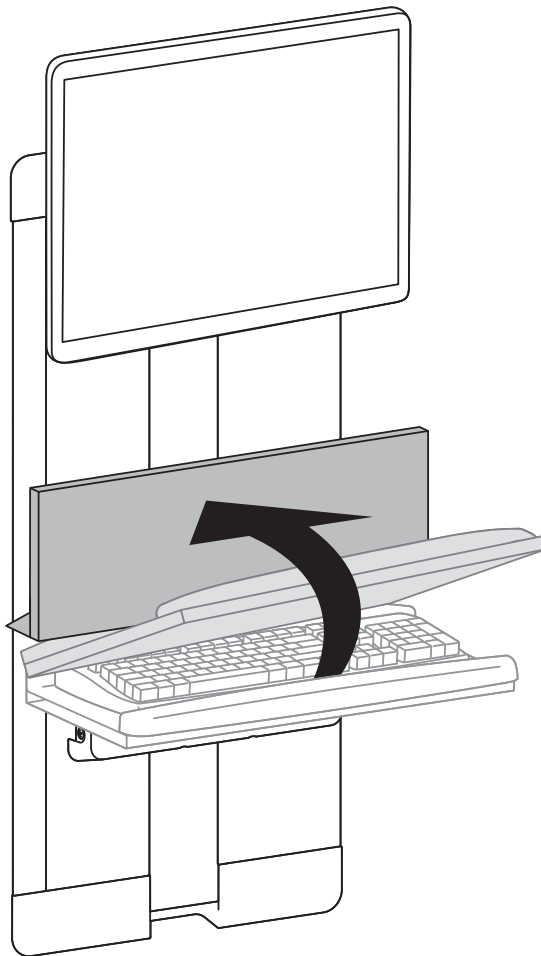

Max Weight Capacity

2.5 lbs
(1.14 kg)

Max Keyboard Depth

<7"
(178 mm)

Minimizing Vertical Lift Storage Profile
 For keyboard to fit under the monitor when in storage position, follow these guidelines:
 Dimension "A" must be no greater than 7-7/8" (200 mm).
 NOTE: Keyboard needs to attach to the lowest set of holes as shown in Step 3

Centerline of Four-Hole VESA FDMI Pattern

A

Rear of Monitor



	A	B	C	D	E
1	1x	1x		4x	1x
2	1x	2x 1x	3x	2x	2x

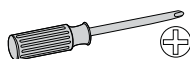

Depending on the design of your VL, you may need any one or combination of these 4 tools to remove your keyboard tray and pivot.

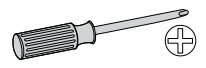
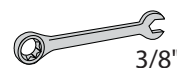

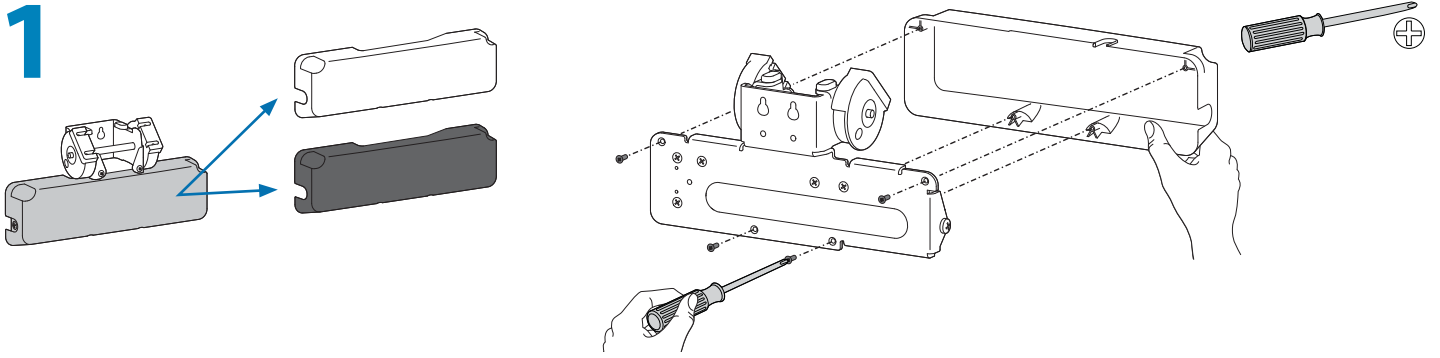

2 a

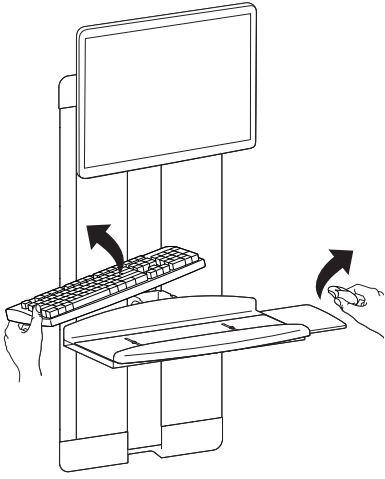

b

Depending on the design of your VL, you may need any one or combination of these 4 tools to remove your keyboard tray and pivot.

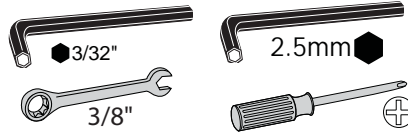

c

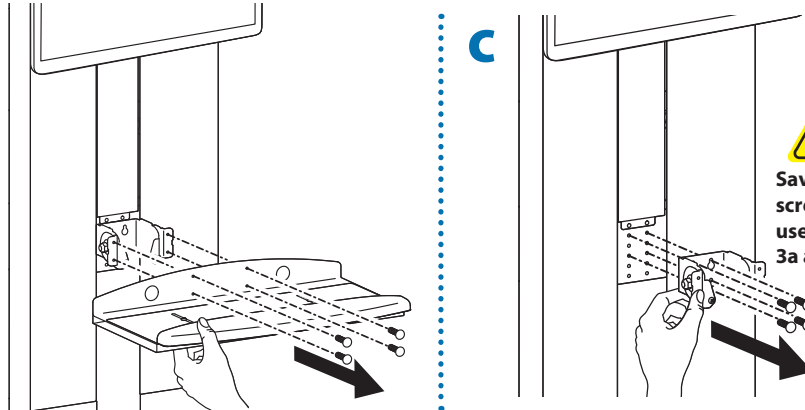

Save these screws for use in steps 3a and 3c.

3 a

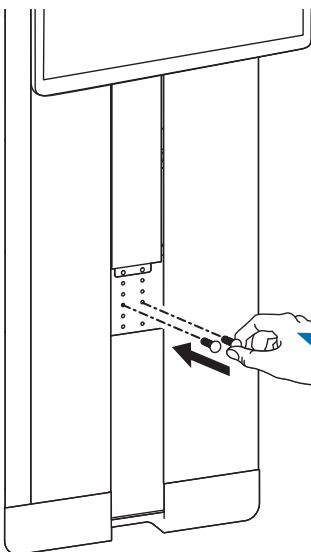

Attach pivot screws to middle set of holes (third up from the bottom set) so pivot attaches at lowest position.

b

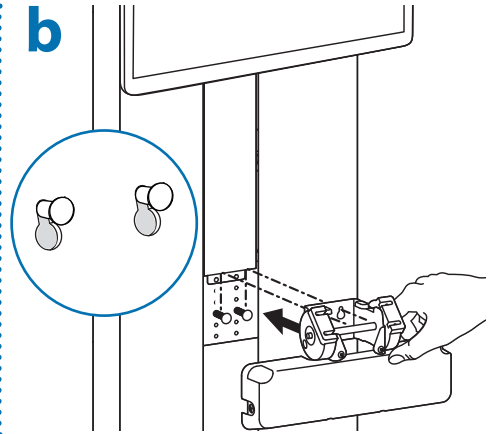

c

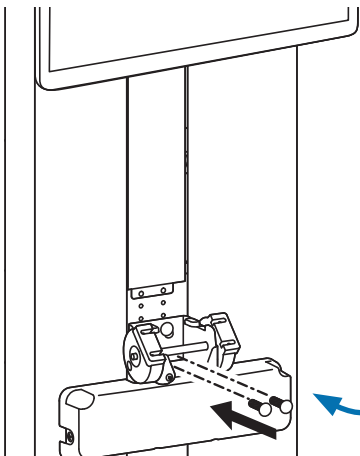

d

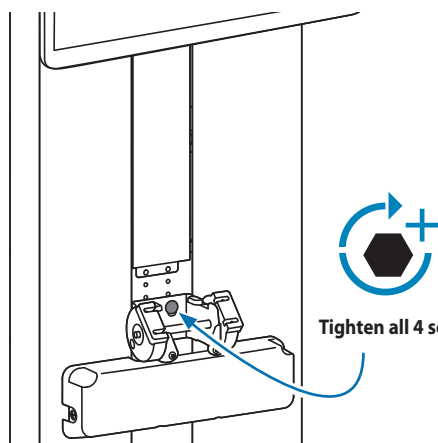

Tighten all 4 screws

4 a

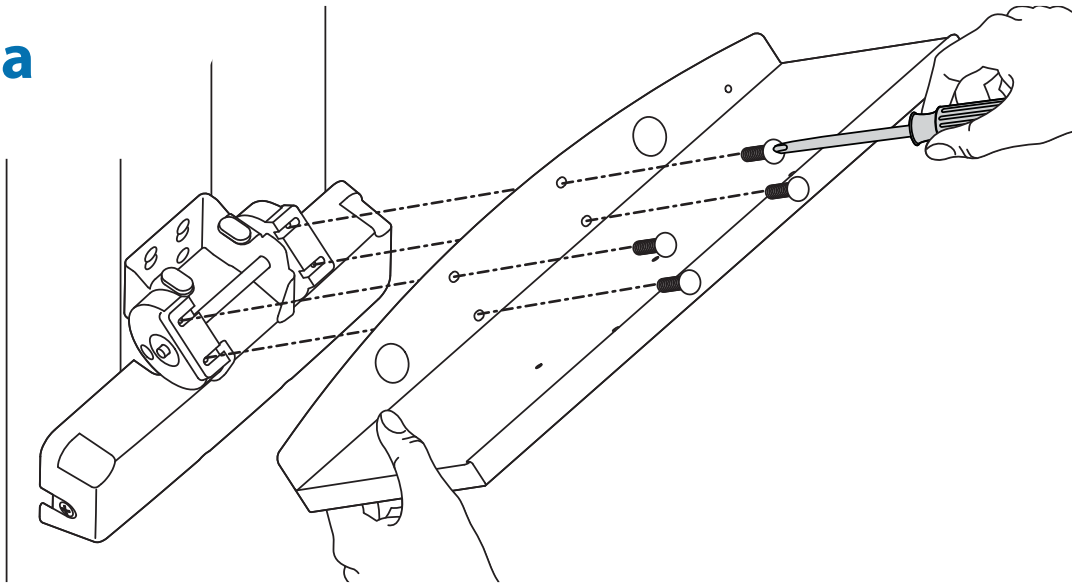

4x 
M4 x 12mm

b REMOVE STOP SCREW BEFORE USE.



CAUTION:

**Product is shipped with a stop screw that MUST be removed before use.
DO NOT REMOVE STOP SCREW BEFORE ATTACHING KEYBOARD TRAY.
Failure to follow these instructions will cause equipment damage.**

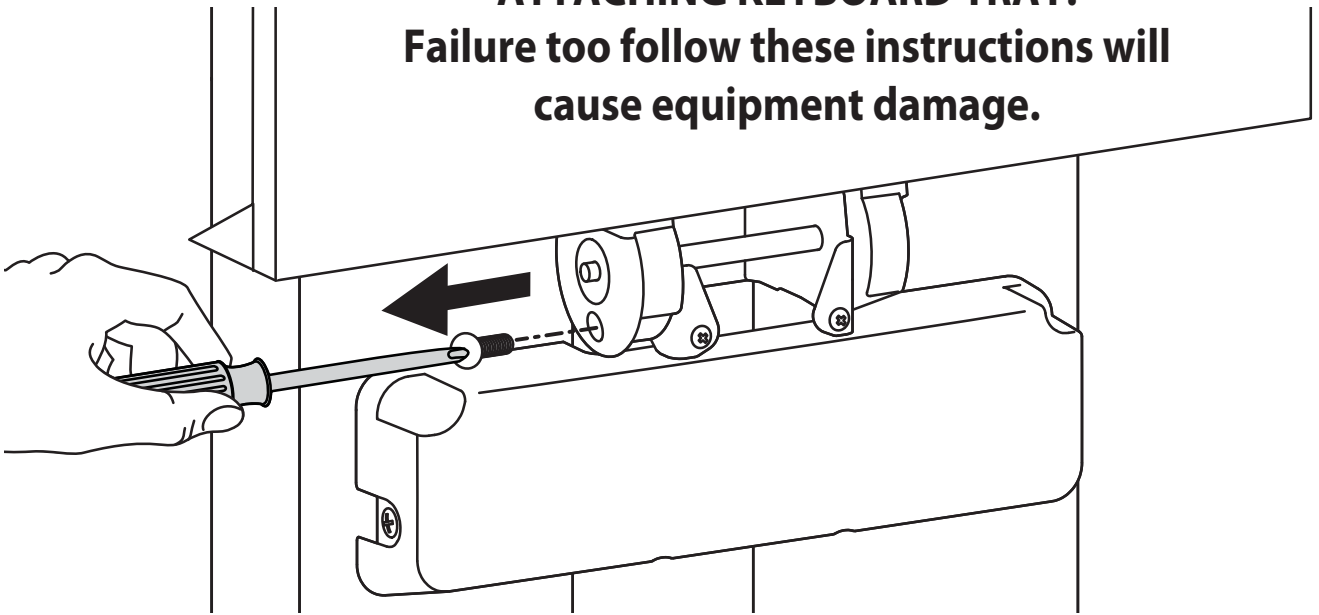

c

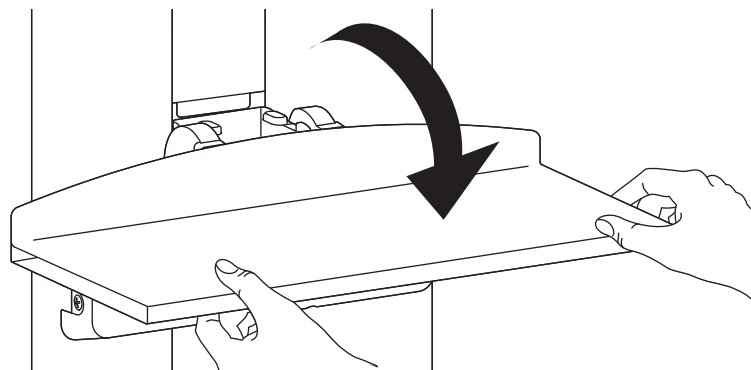

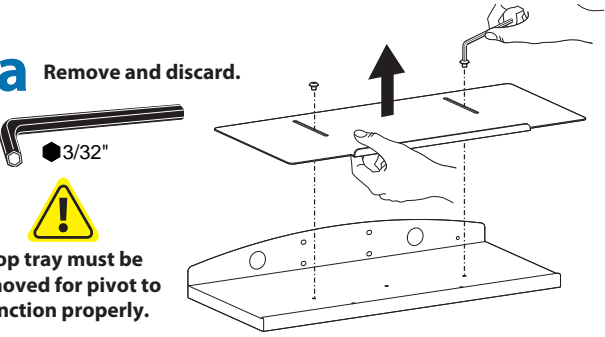
5 a Remove and discard.  **3/32"**

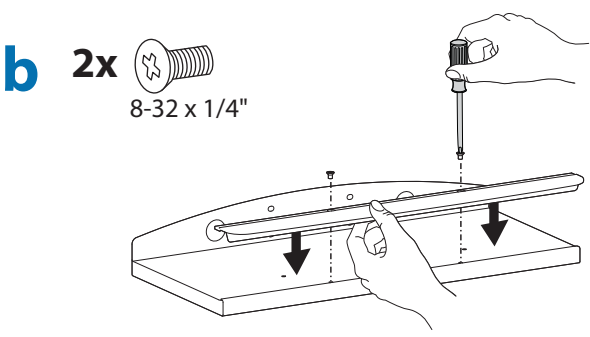
b 2x  8-32 x 1/4"

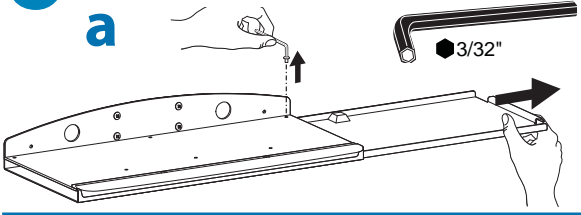

Top tray must be removed for pivot to function properly.

6 Attach the loop (soft) side of the velcro to the bottom of the mouse tray to eliminate rattle when the tray is stowed upright.

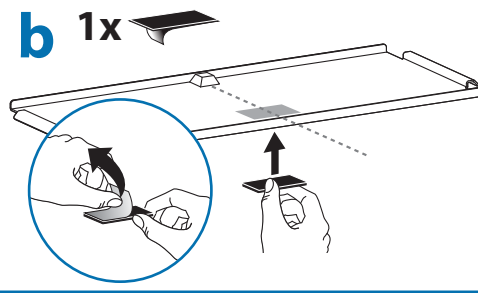
a  **3/32"**

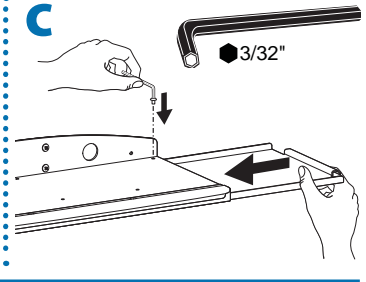
b 1x 

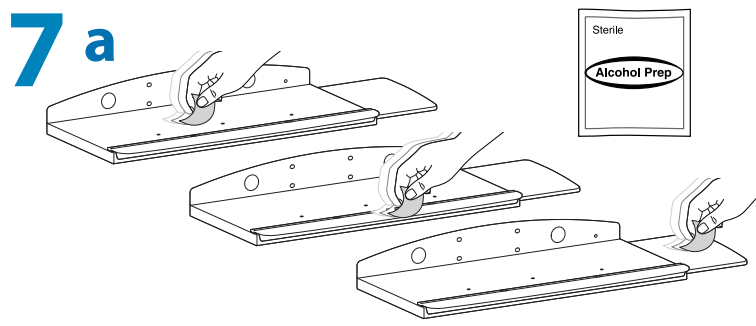
c  **3/32"**

7 a  

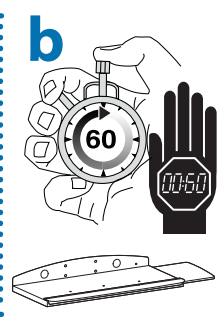
b  60

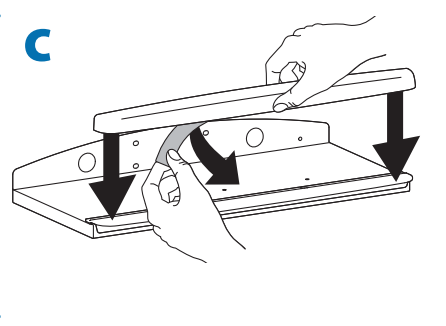
c 

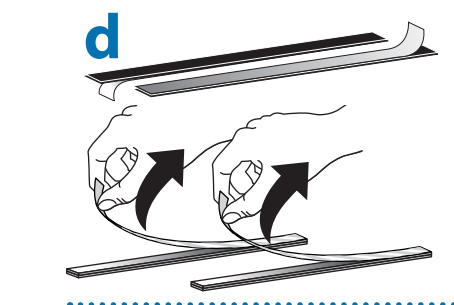
d 

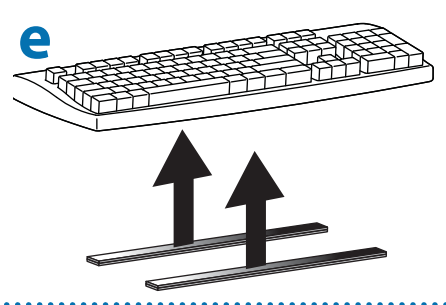
e 

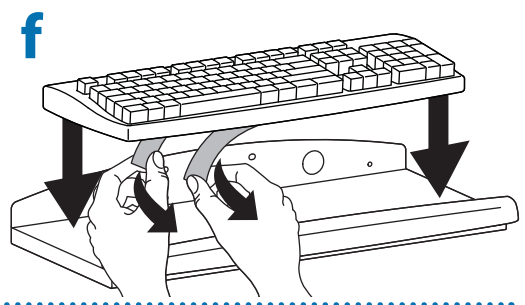
f 

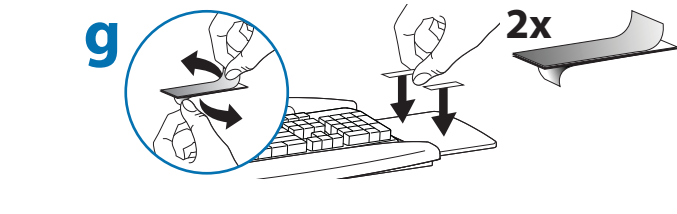
g  2x

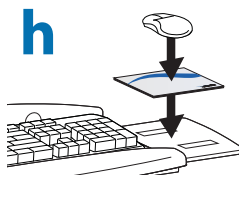
h 

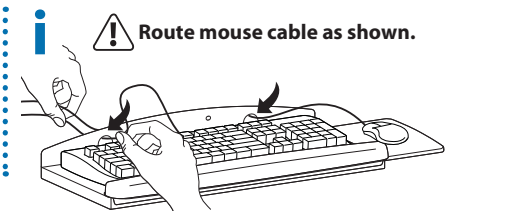
i  **Route mouse cable as shown.**

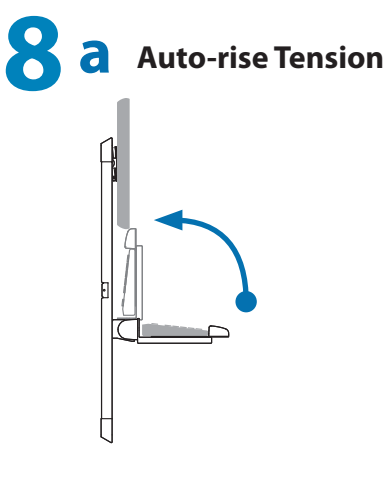
8 a Auto-rise Tension 

 Follow these instructions to tighten or loosen tension.

1. Mount all Equipment (keyboard, wrist rest, mouse pad, mouse, ect.).
2. Tighten screw slowly (turn clockwise) until tray auto rises to full up position. Screw may require several turns

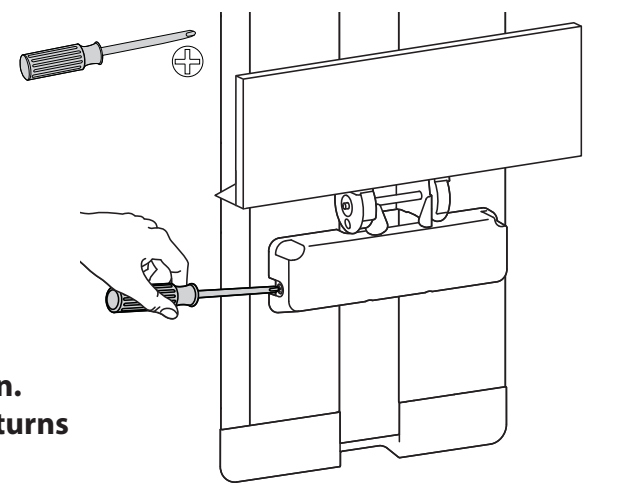

Remove Auto-rise

NOTE: If you would like to remove the auto-rise feature:

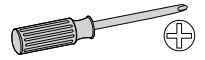

1. Mount all Equipment
(keyboard, wrist rest, mouse pad, mouse, ect.).

2. Loosen screw to decrease the tension
(turn counter clockwise) until the tray no longer auto-rises.



Minimum Weight Capacity

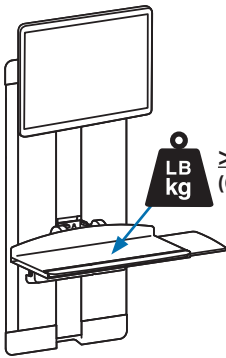

LB
kg ≥ 0.75 lbs
(0.34 kg)

The equipment mounted to the tray must equal 0.75 lbs (0.34 kg) or greater for the tray to stay down with no auto rise.

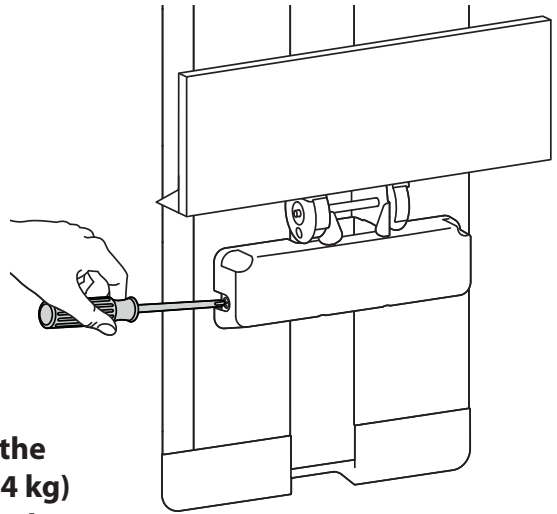

b Tilt

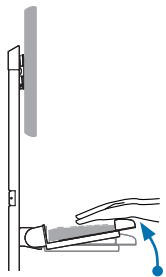
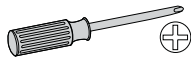

Tighten both screws for less keyboard tilt.



Loosen both screws for more keyboard tilt.

NOTE: Adjust both screws equally.

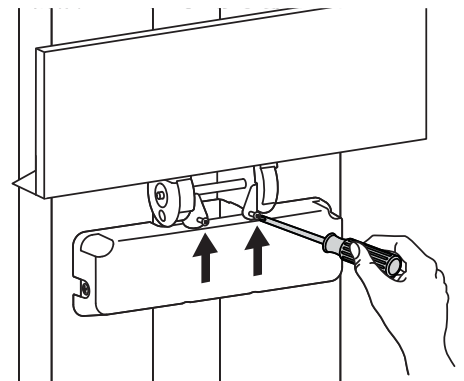

c You may need to adjust lift tension after equipment has been added or removed.

It is important that you adjust this product according to the weight of the mounted equipment as described in the following steps. Any time equipment is added or removed from this product, resulting in a change in the weight of the mounted load, you should repeat these adjustment steps to ensure safe and optimum operation.

Adjustments should move smoothly and easily through the full range of motion and stay where you set it. If adjustments are difficult and do not stay in the desired position, follow the instructions to loosen or tighten the tension to create a smooth, easy adjustment motion. Depending on your product and the adjustment, it may take several turns to notice a difference.

Lift – Up and down



Follow these instructions to tighten or loosen tension.

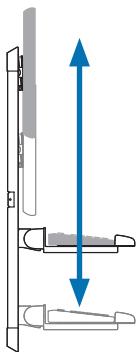
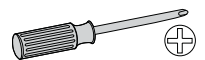

1

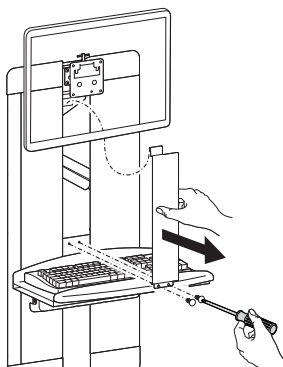

2

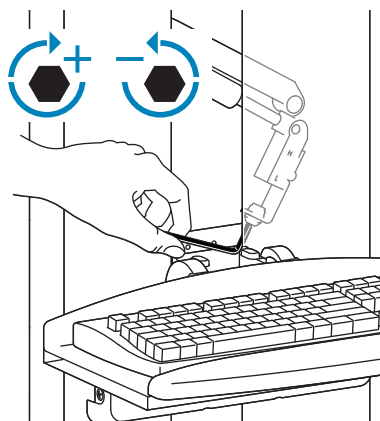

3

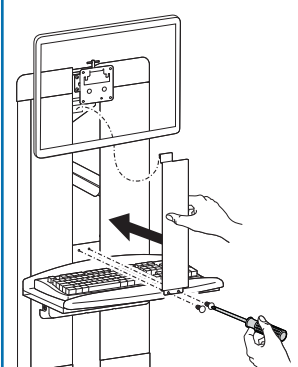

Ergotron Limited Warranty

Ergotron warrants that its products will remain free of defects in material and workmanship for five (5) years. All subject to the exceptions, exclusions and limitations as set forth below.

Exceptions to this warranty include:

- Three (3)-year warranty on all Neo-Flex™ by Ergotron products
- StyleView Carts:
 - Two (2)-year warranty on all power supply components by Ergotron
 - Battery carries an up to a one (1)-year performance warranty (see Limitations below) and six (6)-month warranty against manufacturer's defects. Note: In EU, the warranty against manufacturer's defects is two (2)-years.
 - One (1)-year warranty on all electronic non-power supply components (excludes AA batteries)
- OEM products resold by Ergotron are warranted by the respective manufacturer
- Product that is refurbished by Ergotron and sold by Ergotron carries a 90-day warranty
- Thirty (30)-day warranty on all service programs
- Ergotron warranties are nontransferable

Exclusive Remedy: If any Ergotron equipment is or becomes defective in material or workmanship during the warranty period, Ergotron will determine with the customer if the product defect is covered under warranty. Ergotron, at its sole discretion, may replace or repair the unit determined to be under warranty at a designated Ergotron location or at the customer location. The purchaser must get pre-approved authorization to return product to Ergotron. The Purchaser must contact Ergotron to obtain an RMA (Return Material Authorization) number. Ergotron will promptly repair or replace the item and ship it to Purchaser at no charge to the Purchaser. Performance of repair or replacement does not renew or extend the warranty period.

THIS REMEDY IS THE EXCLUSIVE REMEDY FOR BREACH OF WARRANTY AS TO THE EQUIPMENT, except in respect to personal injury. Purchaser shall give Ergotron immediate written notice of any personal injury resulting from use of Ergotron equipment.

Exclusions and Limitations: Ergotron disclaims liability for injuries or losses caused by or associated with installation or use of its equipment in any manner other than in strict conformance with the instructions set forth in its installation manuals, supplemental assembly and installation instruction sheets, technical bulletins or product literature, or by equipment that has been altered, damaged or misused.

Warranty on fully charged batteries left in an unused state for more than three (3) consecutive months is automatically void. Warranty on fully discharged batteries left in an unused state for more than three (3) consecutive days is automatically void.

Two (2)-year warranty on all power supply components by Ergotron; battery carries a 90 day performance warranty and six (6) month warranty against manufacturer's defects. Performance warranty is extended to 1 year on the battery providing:

- StyleLink software is installed and it shows compliance with exclusions and limitations
- Battery is not discharged below 25% capacity more than 25 times
- Battery is fully recharged at least once every 36 hours

Purchaser has not relied upon and Ergotron disclaims any and all warranties other than the expressed warranty stated above, subject to the exclusions and limitations provided herein. Ergotron disclaims all other warranties, expressed or implied, including but not limited to the warranties of merchantability and fitness for a particular purpose. Ergotron further disclaims liability to purchaser and all others for all consequential, incidental and special damages caused by or in connection with the products, their use or misuse, and their performance or nonperformance.



© 2011 Ergotron, Inc.
All rights reserved.

While Ergotron, Inc. makes every effort to provide accurate and complete information on the installation and use of its products, it will not be held liable for any editorial errors or omissions (including those made in the process of translation from English to another language), or for incidental, special or consequential damages of any nature resulting from furnishing this instruction and performance of equipment in connection with this instruction. Ergotron, Inc. reserves the right to make changes in the product design and/or product documentation without notification to its users. For the most current product information, or to know if this document is available in languages other than those herein, please contact Ergotron. No part of this publication may be reproduced, stored in a retrieval system, or transmitted in any form or by any means, electronic, mechanical, photocopying, recording or otherwise without the prior written consent of Ergotron, Inc., 1181 Trapp Road, Eagan, Minnesota, 55121, USA. Patents Pending and Patented U.S. & Foreign. Ergotron is a registered trademark of Ergotron, Inc.

<p>Americas Sales and Corporate Headquarters</p> <p>St. Paul, MN USA (800) 888-8458 +1-651-681-7600 www.ergotron.com sales@ergotron.com</p>	<p>EMEA Sales</p> <p>Amersfoort, The Netherlands +31 33 45 45 600 www.ergotron.com info.eu@ergotron.com</p>
<p>APAC Sales</p> <p>Tokyo, Japan www.ergotron.com apaccustomerservice@ergotron.com</p>	<p>Worldwide OEM Sales</p> <p>www.ergotron.com info.oem@ergotron.com</p>