

# StyleView Accessory, Utility Shelf

[www.ergotron.com](http://www.ergotron.com)  
 USA 1-800-888-8458  
 Europe +31 (0)33-45 45 600  
 China 86-769-86018920

**ASSEMBLY INSTRUCTIONS**, StyleView Accessory, Utility Shelf  
**Instrucciones de instalación**, Accesorio StyleView, Estantería de servicios generales  
**Notice d'assemblage**, Accessoire StyleView, Étagère de rangement  
**Montageanleitung**, Zubehör für StyleView, Ablagefach  
**Installatie instructies**, Accessoire StyleView, plank  
**Manuali d'Istruzione**, Accessorio StyleView, Scaffale per applicazioni  
 取扱説明書, スタイルビューアクセサリ, ユーティリティシェルフ  
 安装说明, StyleView 附件, 设备托架  
 , StyleView

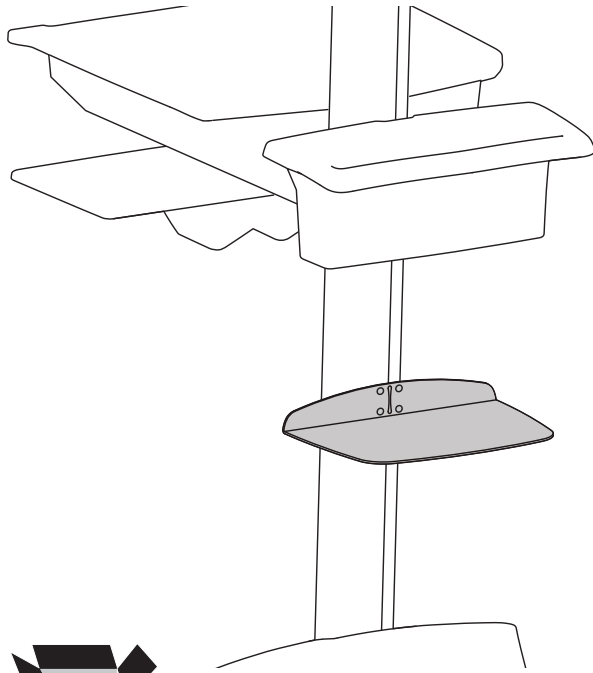

205 Westwood Ave, Long Branch, NJ 07740  
 Phone: 866-94 BOARDS (26273) / (732)-222-1511  
 Fax: (732)-222-7088 | E-mail: [sales@touchboards.com](mailto:sales@touchboards.com)

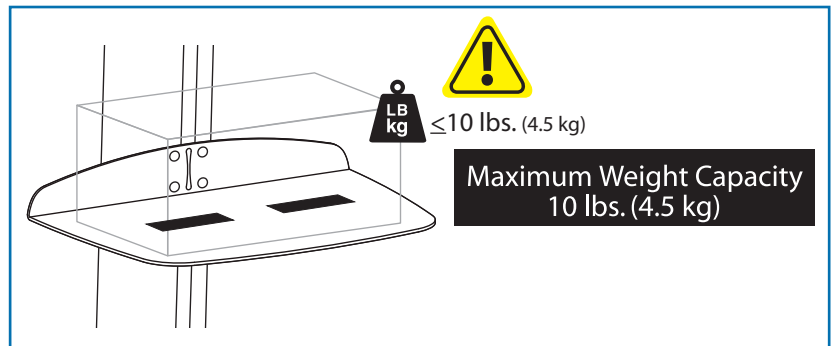

	A		B	
1	1x		1x	2x
	<b>Mounting Hardware, 1 T-Slot</b>		<b>Mounting Hardware, 2 T-Slot</b>	
2	1x	1x	2x	1x
3	4x  M5 x 6mm	4x  M5 x 6mm	4x  M5 x 6mm	4x  M5 x 6mm
4	2x  M5 x 13mm	2x  M5 x 13mm	4x  M5 x 10mm	4x  M5 x 10mm
5	1x		1x	

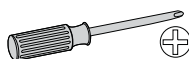

# Mounting Hardware, 1 T-Slot

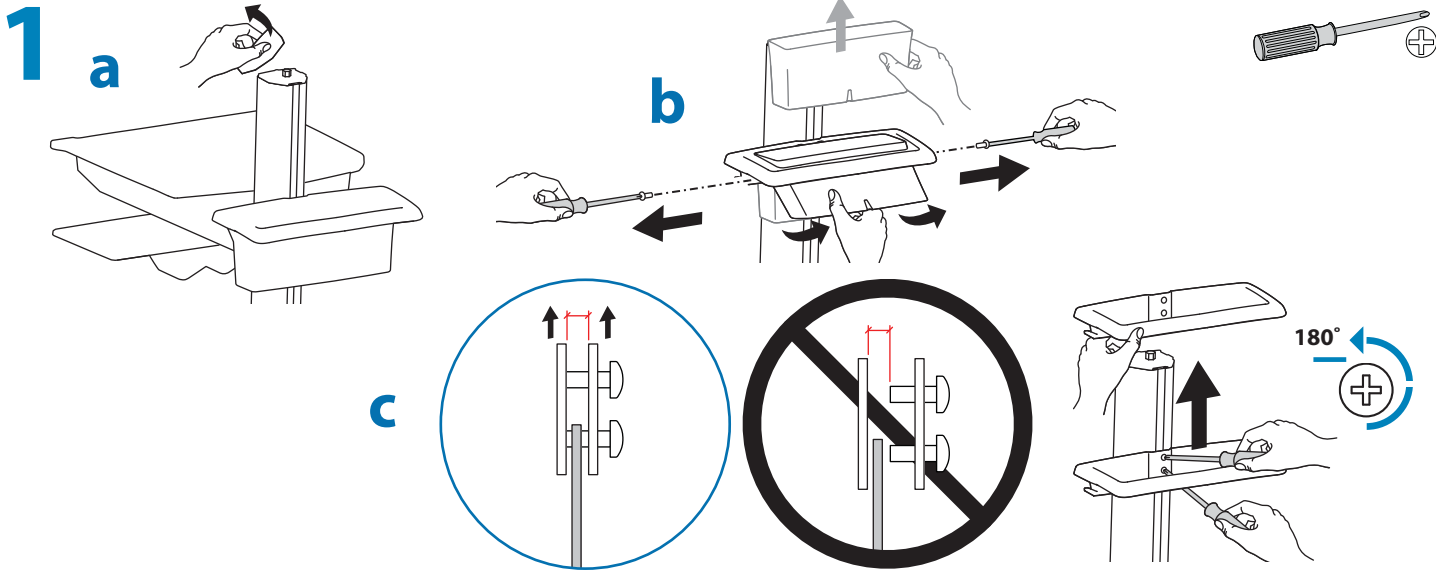

**4x**  
 M5 x 6mm

Security Screw  
 Tornillo de seguridad  
 Vis de sécurité  
 Sicherheitsschraube mit Innenfünfkant  
 Veiligheidssleutel  
 Vite di sicurezza  
 固定ネジ  
 安全螺丝  
 Security Screw( )



5-sided Security Wrench  
 Llave de seguridad pentagonal  
 Clef Allen de sécurité  
 Fünfkant-Inbusschlüssel  
 5-kantige veiligheidsleutel  
 Chiave pentagonale di sicurezza  
 5角固定用レンチ  
 5角安全扳手  
 5 Security Wrench( )

**2**

**4x**  
 M5 x 6mm

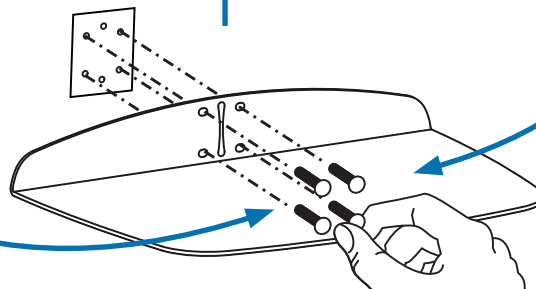
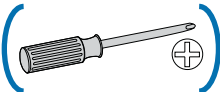

**2x**  
 M5 x 13mm

Security Screw  
 Tornillo de seguridad  
 Vis de sécurité  
 Sicherheitsschraube mit Innenfünfkant  
 Veiligheidssleutel  
 Vite di sicurezza  
 固定ネジ  
 安全螺丝  
 Security Screw( )



5-sided Security Wrench  
 Llave de seguridad pentagonal  
 Clef Allen de sécurité  
 Fünfkant-Inbusschlüssel  
 5-kantige veiligheidsleutel  
 Chiave pentagonale di sicurezza  
 5角固定用レンチ  
 5角安全扳手  
 5 Security Wrench( )

**3**

**2x**  
 M5 x 13mm

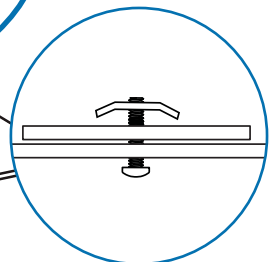
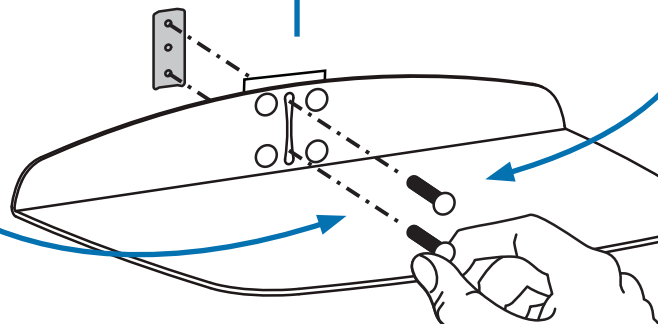
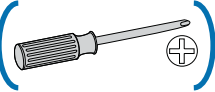

# Mounting Hardware, 1 T-Slot

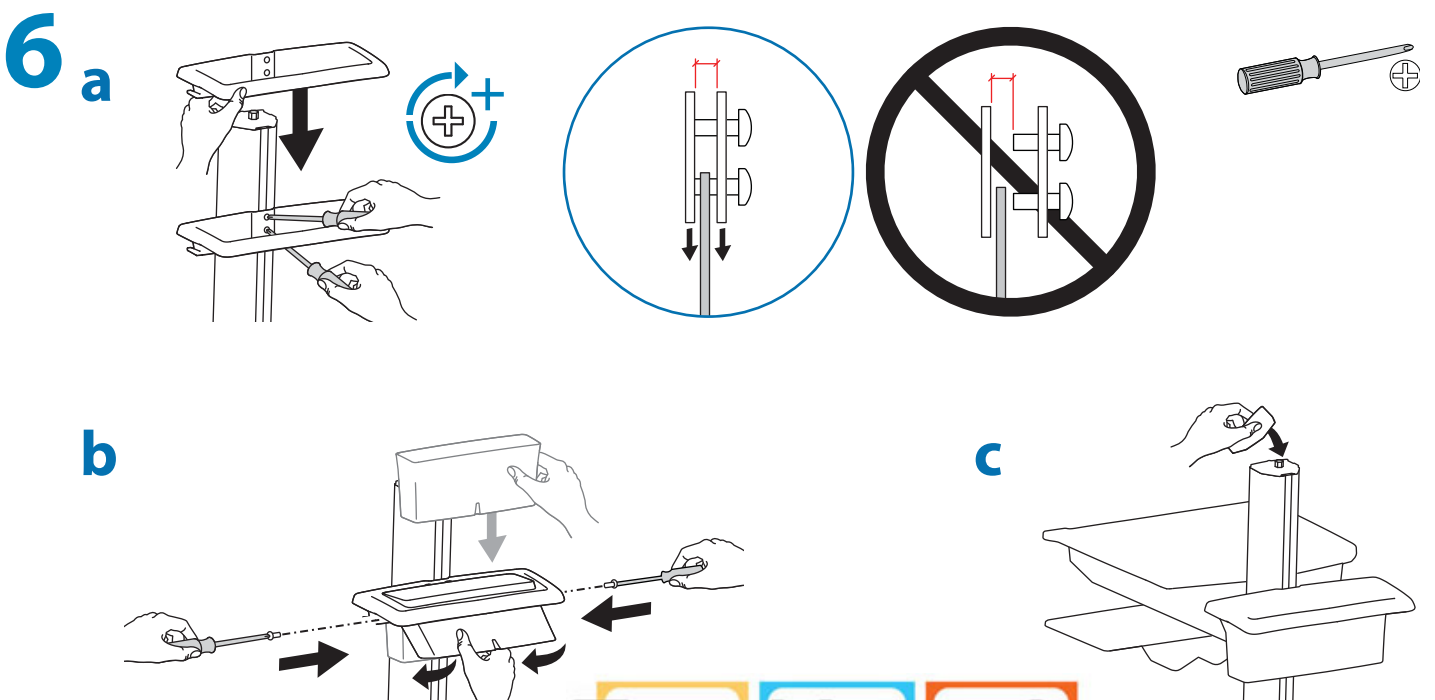
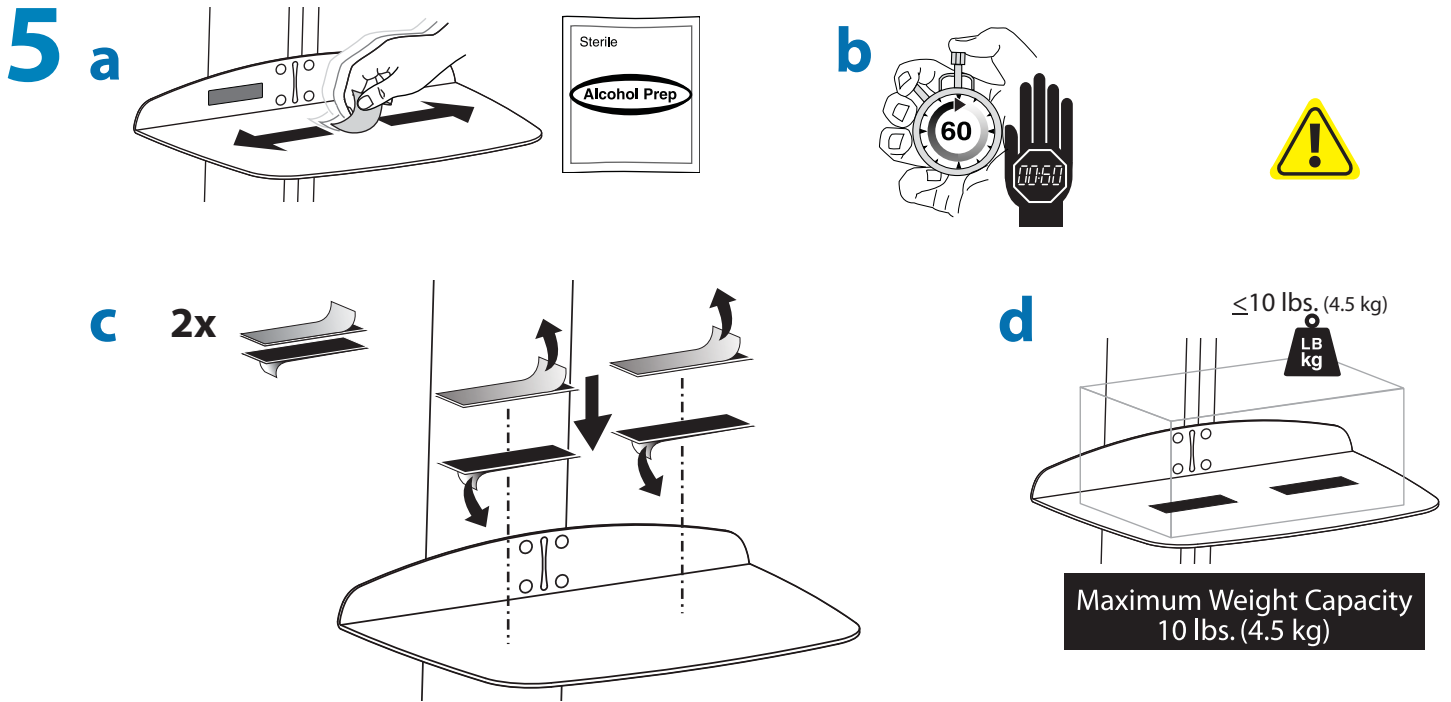
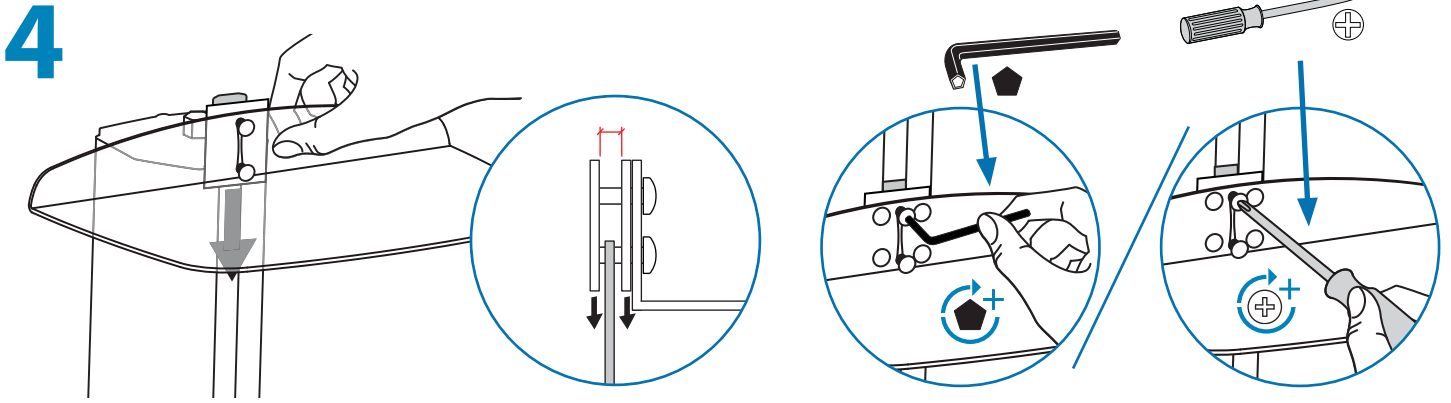

# Touchboards

# Mounting Hardware, 2 T-Slot

**1 a**

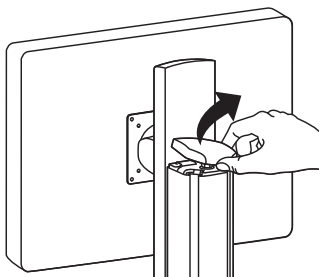

**b**

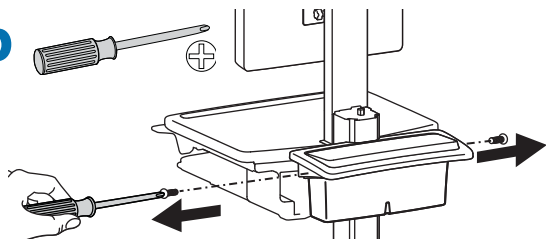

**c**

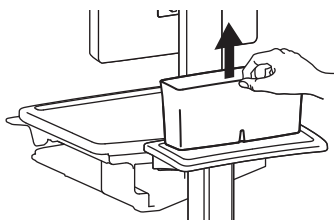

**2**

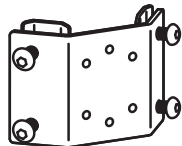
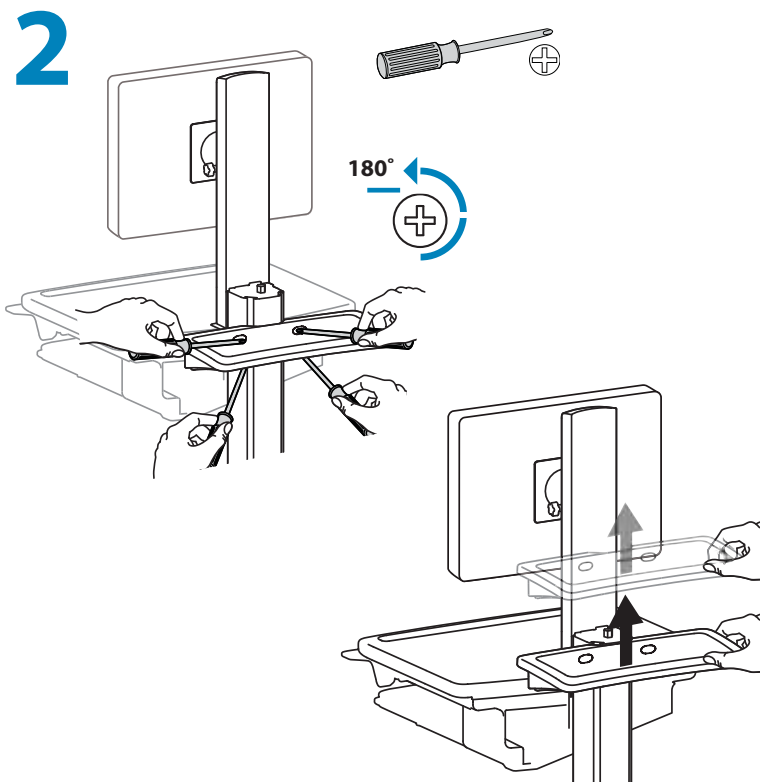

**3**

**4x**



M5 x 10mm

Security Screw  
Tornillo de seguridad  
Vis de sécurité  
Sicherheitsschraube mit Innenfünfkant  
Veiligheidssleutel  
Vite di sicurezza  
固定ネジ  
安全螺丝  
Security Screw( )



5-sided Security Wrench  
Llave de seguridad pentagonal  
Clef Allen de sécurité  
Fünfkant-Inbusschlüssel  
5-kantige veiligheidssleutel  
Chiave pentagonale di sicurezza  
5角固定用レンチ  
5角安全扳手  
5 Security Wrench( )

**4x**



M5 x 10mm

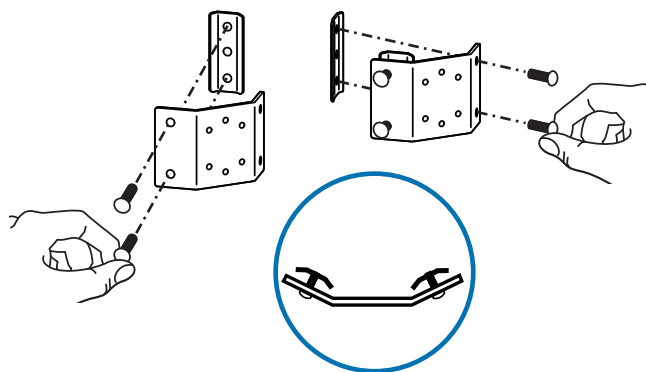
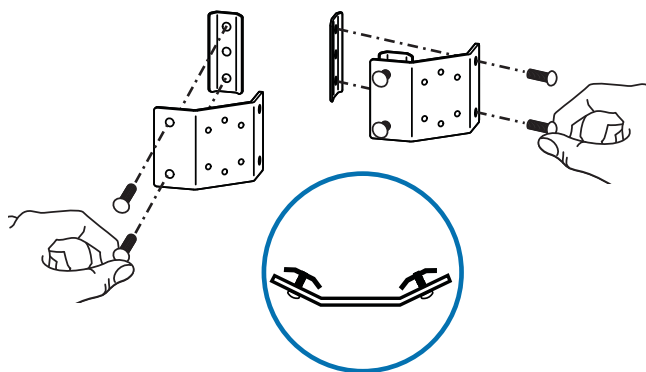
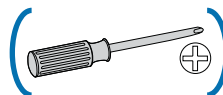

# Mounting Hardware, 2 T-Slot

**4a**

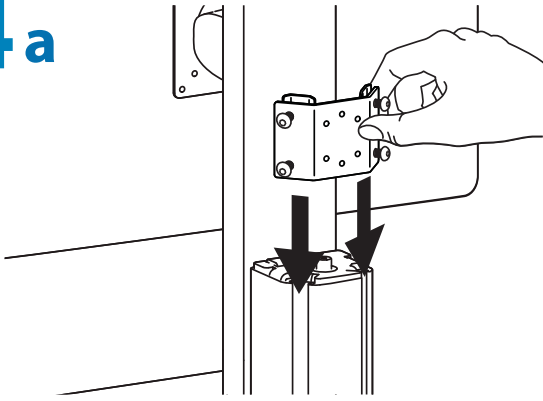

**b**

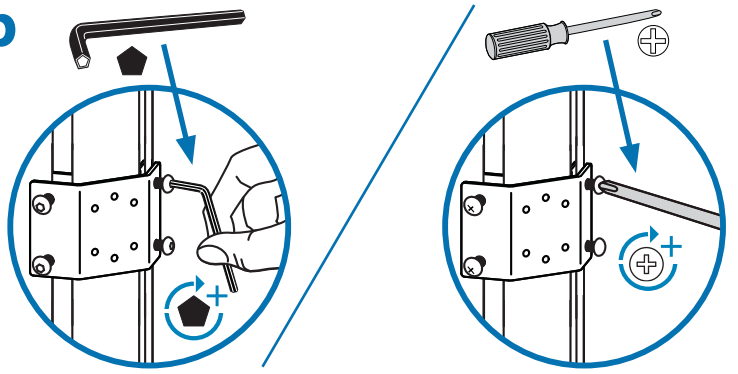

**4x**



M5 x 6mm  
 Security Screw  
 Tornillo de seguridad  
 Vis de sécurité  
 Sicherheitsschraube mit Innenfünfkant  
 Veiligheidsleutel  
 Vite di sicurezza  
 固定ネジ  
 安全螺丝  
 Security Screw( )

**5**



5-sided Security Wrench  
 Llave de seguridad pentagonal  
 Clef Allen de sécurité  
 Fünfkant-Inbusschlüssel  
 5-kantige veiligheidsleutel  
 Chiave pentagonale di sicurezza  
 5角固定用レンチ  
 5角安全扳手  
 5 Security Wrench( )

**4x**

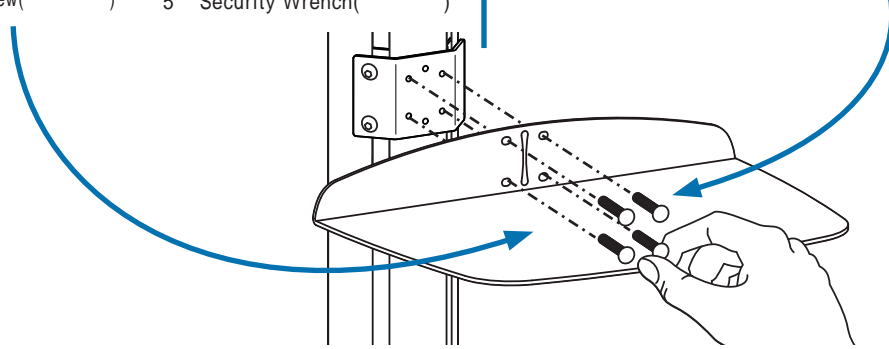
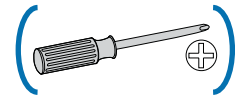
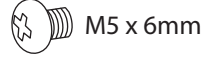

**6a**

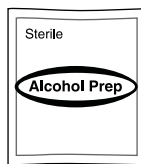
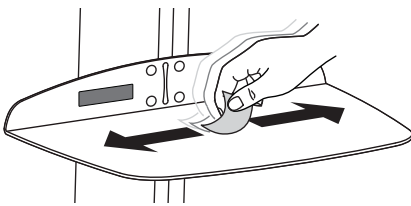

**b**

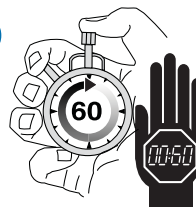

**c** **2x**

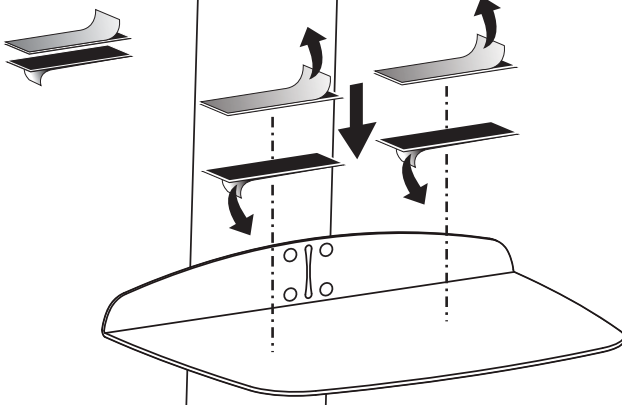

**d**

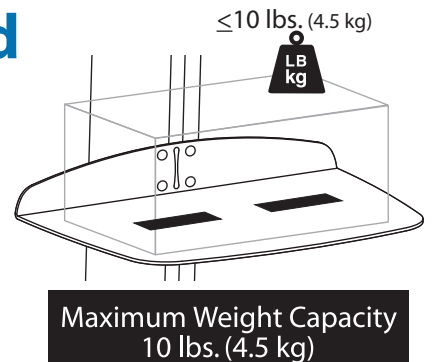

**Maximum Weight Capacity**  
 10 lbs. (4.5 kg)

## Mounting Hardware, 2 T-Slot

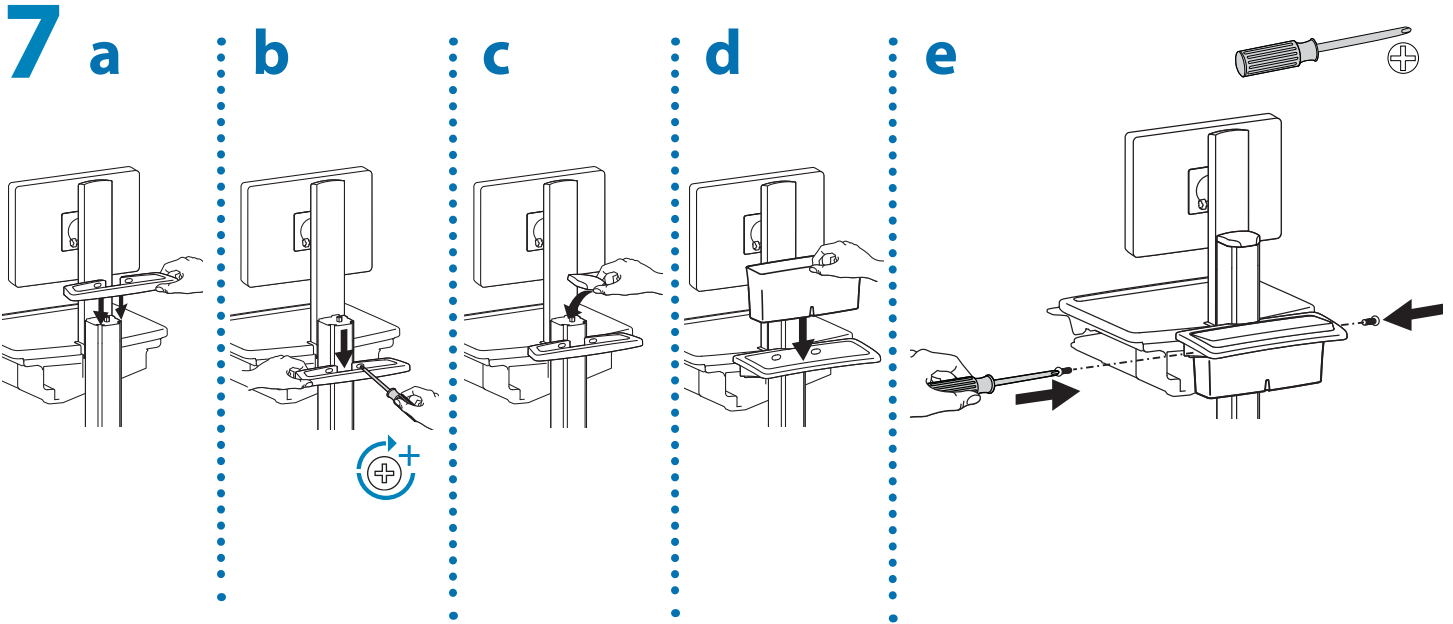

# Touchboards

205 Westwood Ave, Long Branch, NJ 07740  
 Phone: 866-94 BOARDS (26273) / (732)-222-1511  
 Fax: (732)-222-7088 | E-mail: sales@touchboards.com



© 2012 Ergotron, Inc.  
 All rights reserved.

While Ergotron, Inc. makes every effort to provide accurate and complete information on the installation and use of its products, it will not be held liable for any editorial errors or omissions (including those made in the process of translation from English to another language), or for incidental, special or consequential damages of any nature resulting from furnishing this instruction and performance of equipment in connection with this instruction. Ergotron, Inc. reserves the right to make changes in the product design and/or product documentation without notification to its users. For the most current product information, or to know if this document is available in languages other than those herein, please contact Ergotron. No part of this publication may be reproduced, stored in a retrieval system, or transmitted in any form or by any means, electronic, mechanical, photocopying, recording or otherwise without the prior written consent of Ergotron, Inc., 1181 Trapp Road, Eagan, Minnesota, 55121, USA. Patents Pending and Patented U.S. & Foreign. Ergotron is a registered trademark of Ergotron, Inc.

### Americas Sales and Corporate Headquarters

St. Paul, MN USA  
 (800) 888-8458  
 +1-651-681-7600  
 www.ergotron.com  
 sales@ergotron.com

### EMEA Sales

Amersfoort, The Netherlands  
 +31 33 45 45 600  
 www.ergotron.com  
 info.eu@ergotron.com

### APAC Sales

Tokyo, Japan  
 www.ergotron.com  
 apaccustomerservice@ergotron.com

### Worldwide OEM Sales

www.ergotron.com  
 info.oem@ergotron.com