

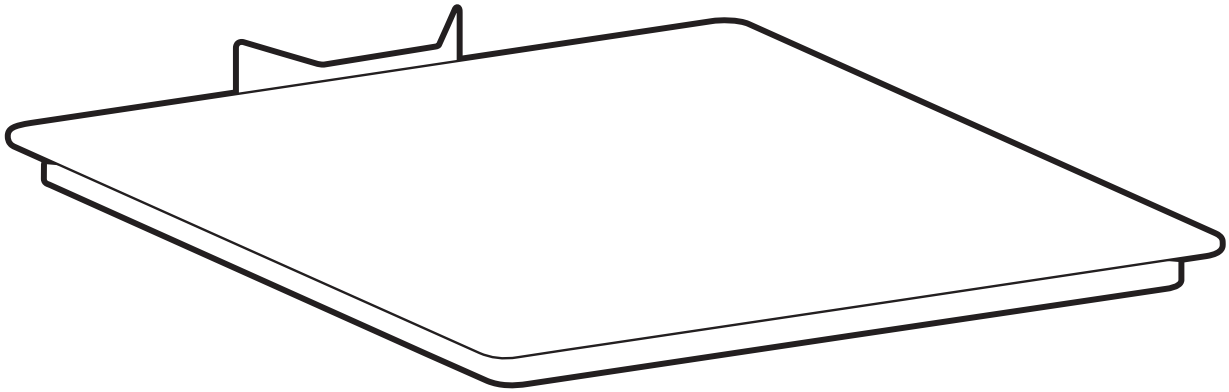

Touchboards

205 Westwood Ave, Long Branch, NJ 07740
Phone: 866-94 BOARDS (26273) / (732)-222-1511
Fax: (732)-222-7088 | E-mail: sales@touchboards.com

User's Guide Large Utility Shelf



ENGLISH

For the latest User Installation Guide please visit: www.ergotron.com



User's Guide - English
Guía del usuario - Español
Manuel de l'utilisateur - Français
Gebruikersgids - Deutsch
Benutzerhandbuch - Nederlands
Guida per l'utente - Italiano
Användarhandbok - svenska
ユーザーガイド : 日本語
用户指南 : 汉语



www.ergotron.com
USA 1-800-888-8458
Europe +31 (0)33-45 45 600
China 86-769-86018920

Features & Specifications

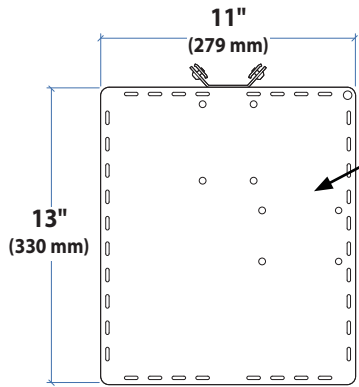

Weight Capacity:

Cart mount ≤ 8 lbs (3.6 kg)

Wall Track Mount ≤ 25 lbs (11.3 kg)

Wall Plate Mount ≤ 25 lbs (11.3 kg)



CAUTION: DO NOT EXCEED MAXIMUM LISTED WEIGHT CAPACITY. SERIOUS INJURY OR PROPERTY DAMAGE MAY OCCUR!

Components



	A	B	C
1	1x 	1x 2x 	Security Screw 1x M4 x 6mm
2	5-sided Security Wrench 1x 5mm 1x 4mm	2x M5 x 13mm 1x 	4x 8-32 x 3/8"
3	1x 3/32" 1x 3mm	4x M4 x 12mm	4x M5 x 10mm

Tools Needed

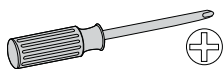

1

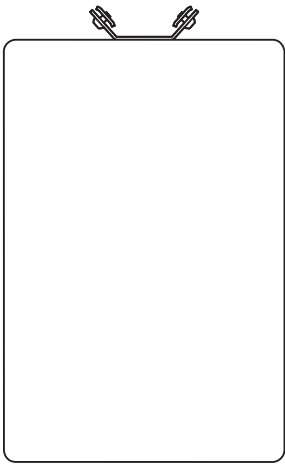

→ 2

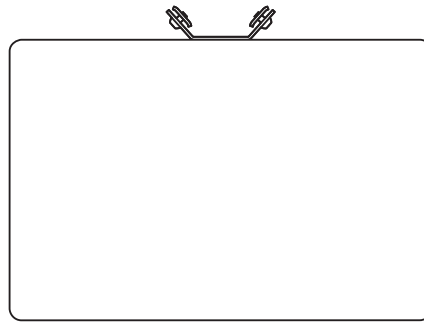

5-sided Security Wrench



a

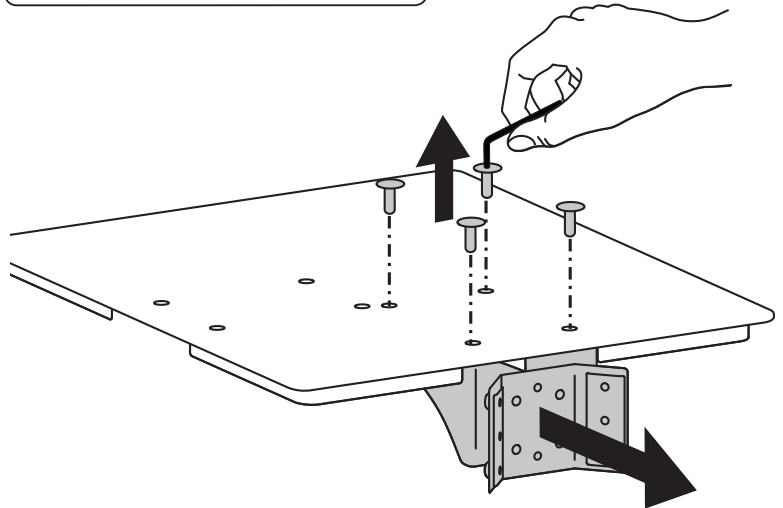

b

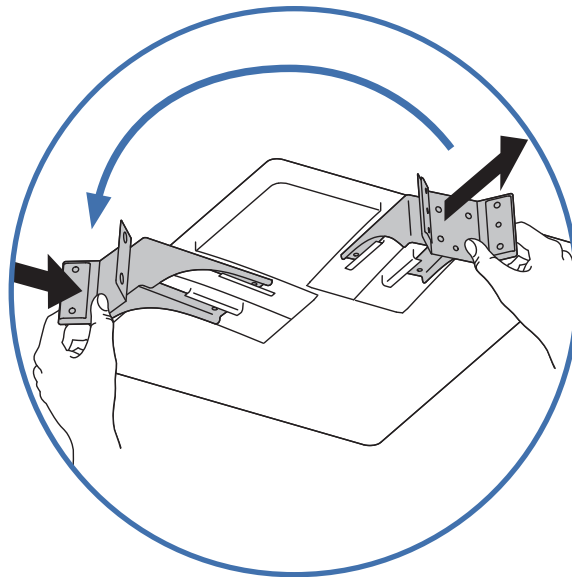

c

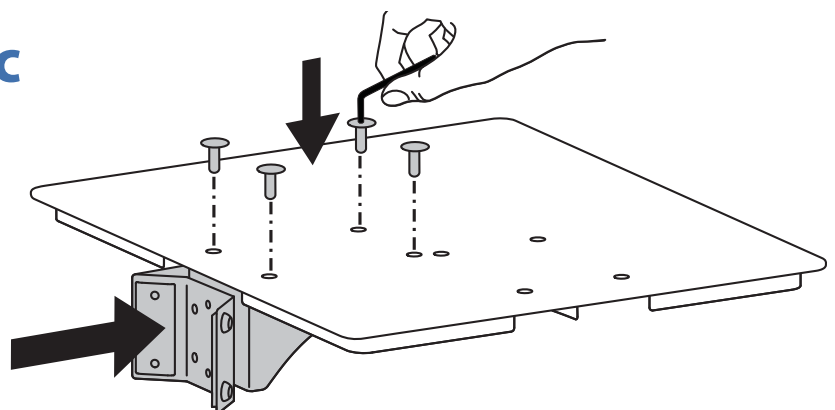

2

Cart Mount

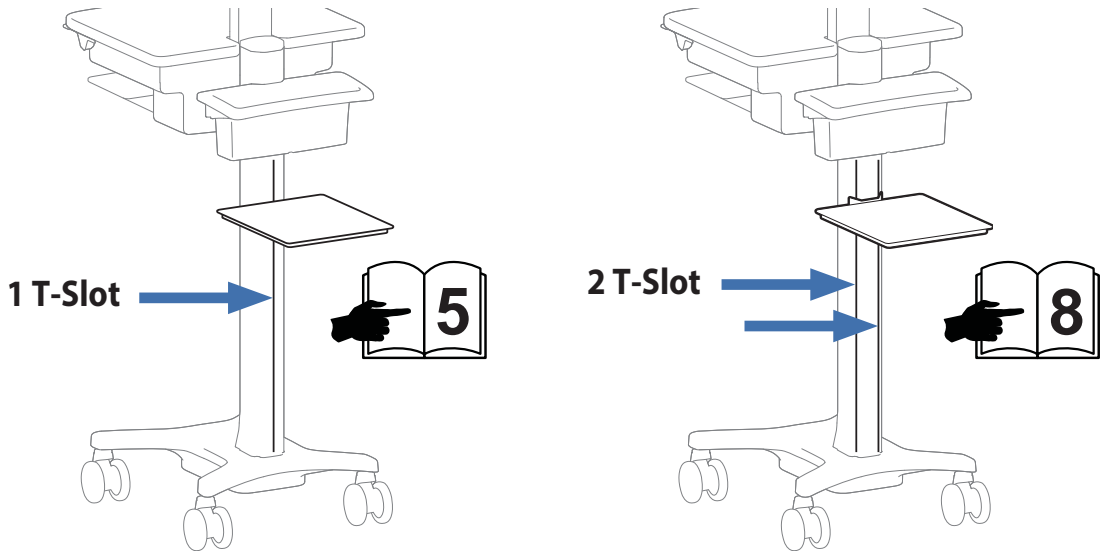

Wall Track Mount

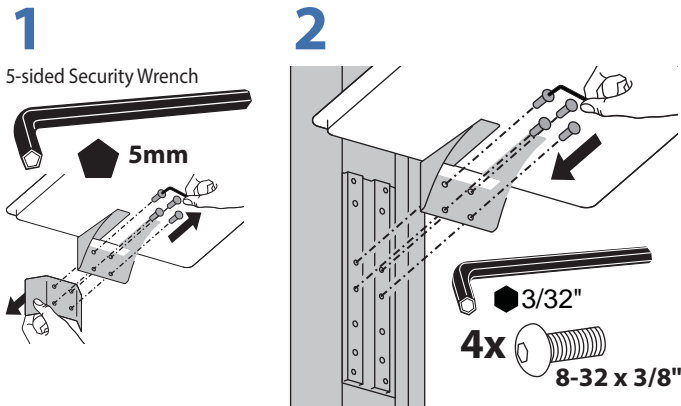

NOTE: Brackets sold separately.

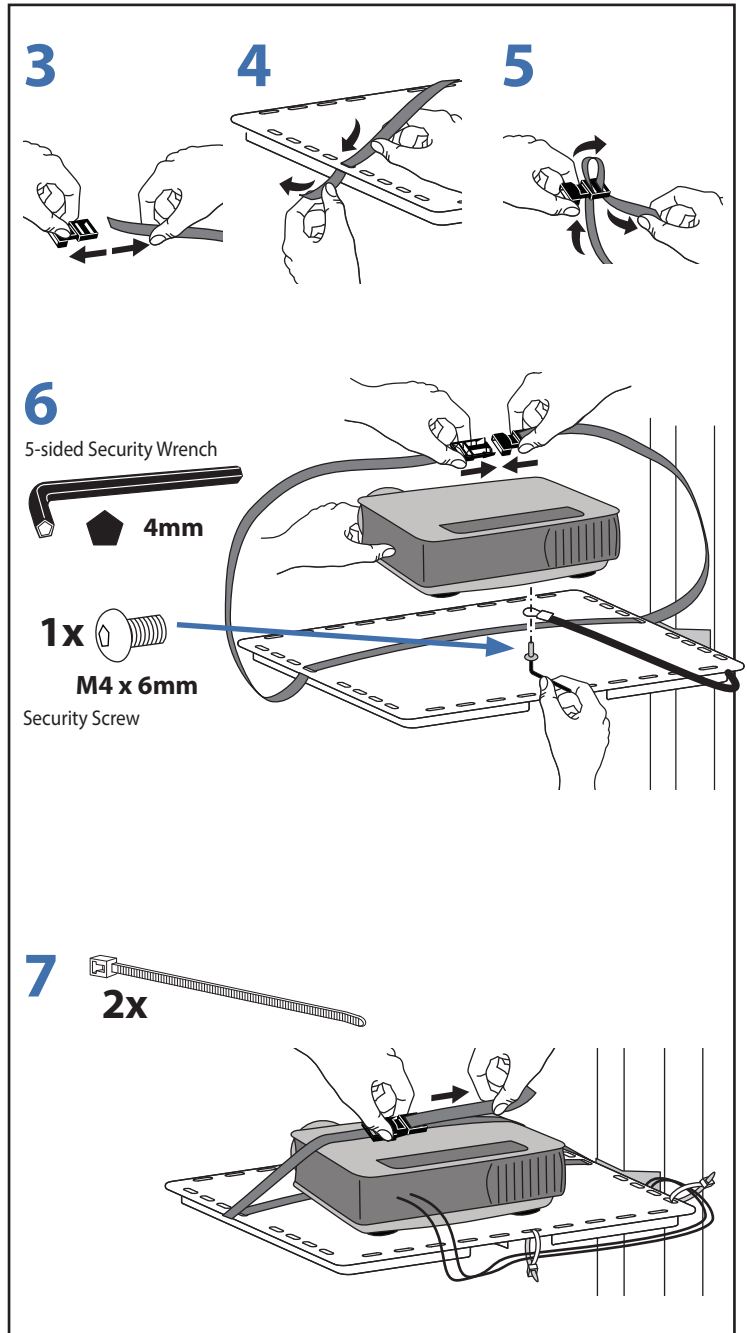

Wall Plate Mount

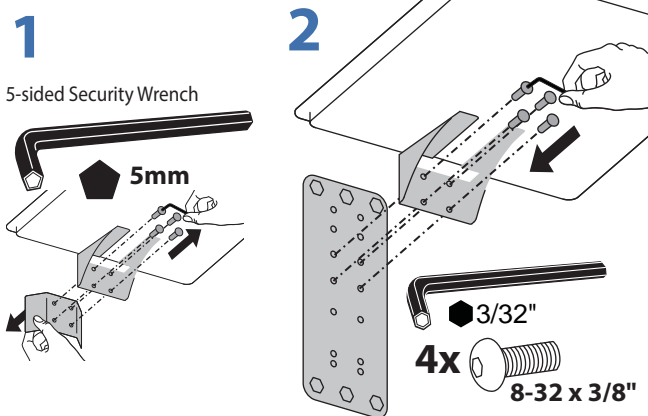

NOTE: Brackets sold separately.

1 T-Slot

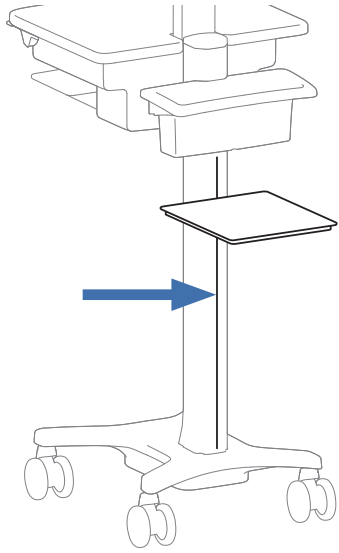

3 a

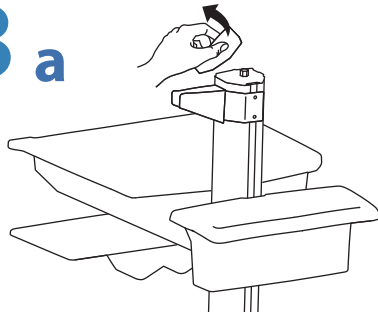

b

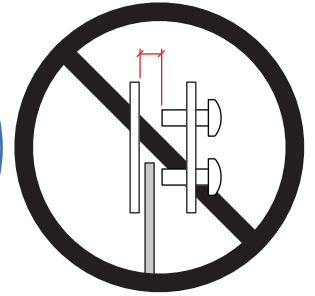
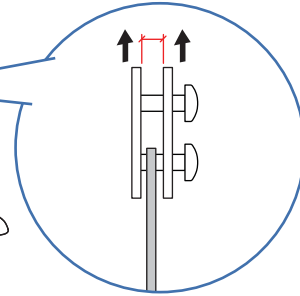
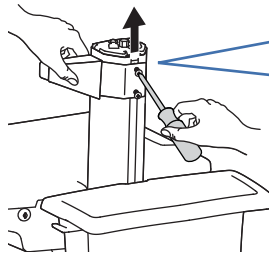

c

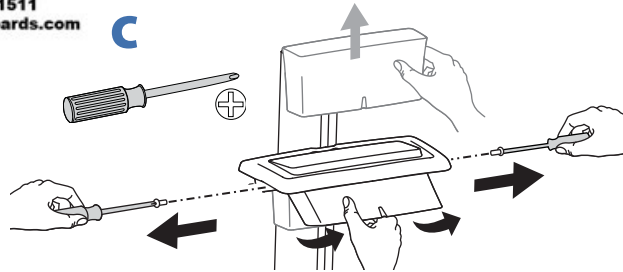

Touchboards

205 Westwood Ave, Long Branch, NJ 07740
 Phone: 866-94 BOARDS (26273) / (732)-222-1511
 Fax: (732)-222-7088 | E-mail: sales@touchboards.com

4

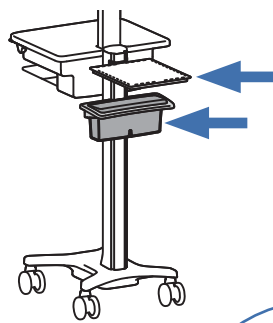
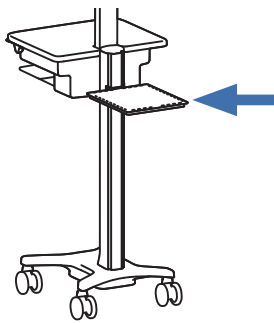
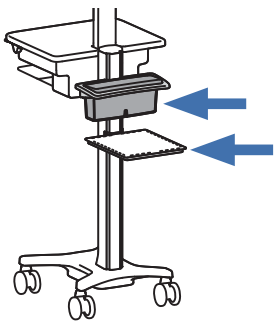

a

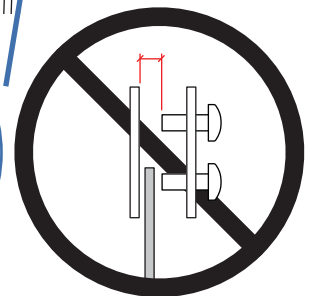
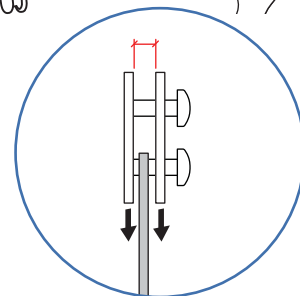
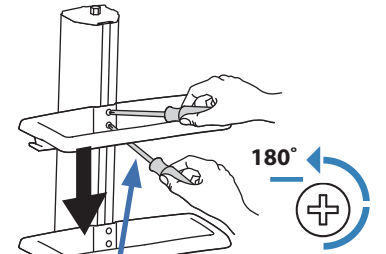

b

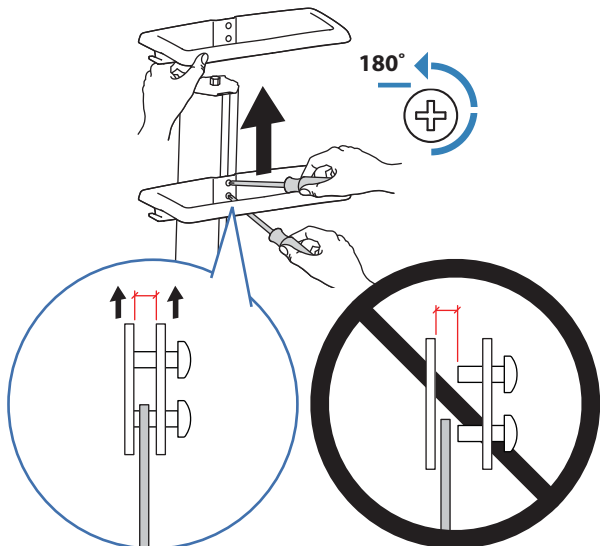
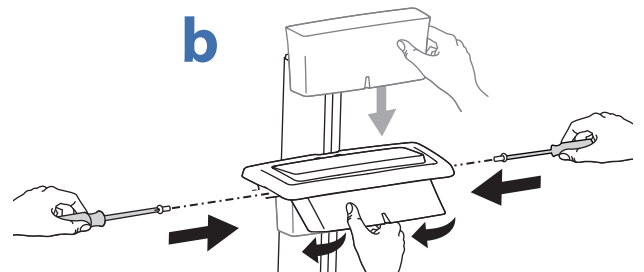

1 T-Slot

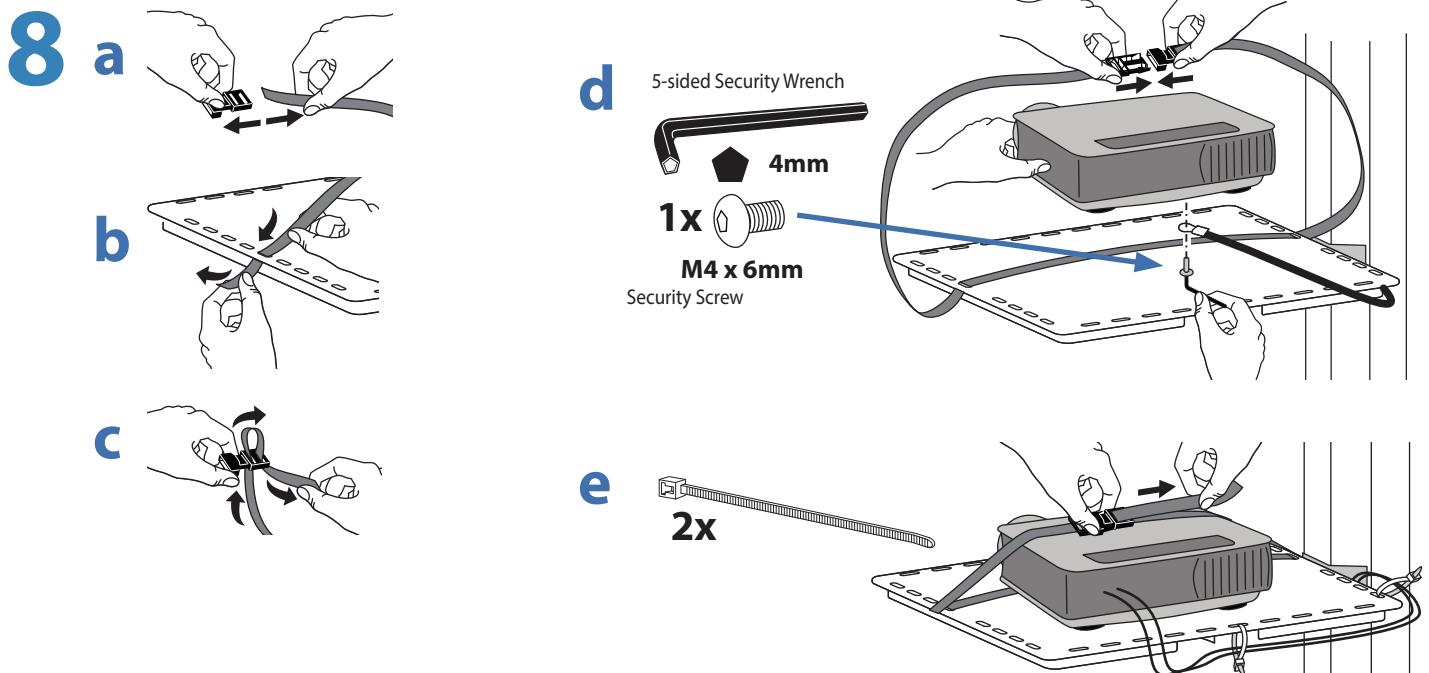
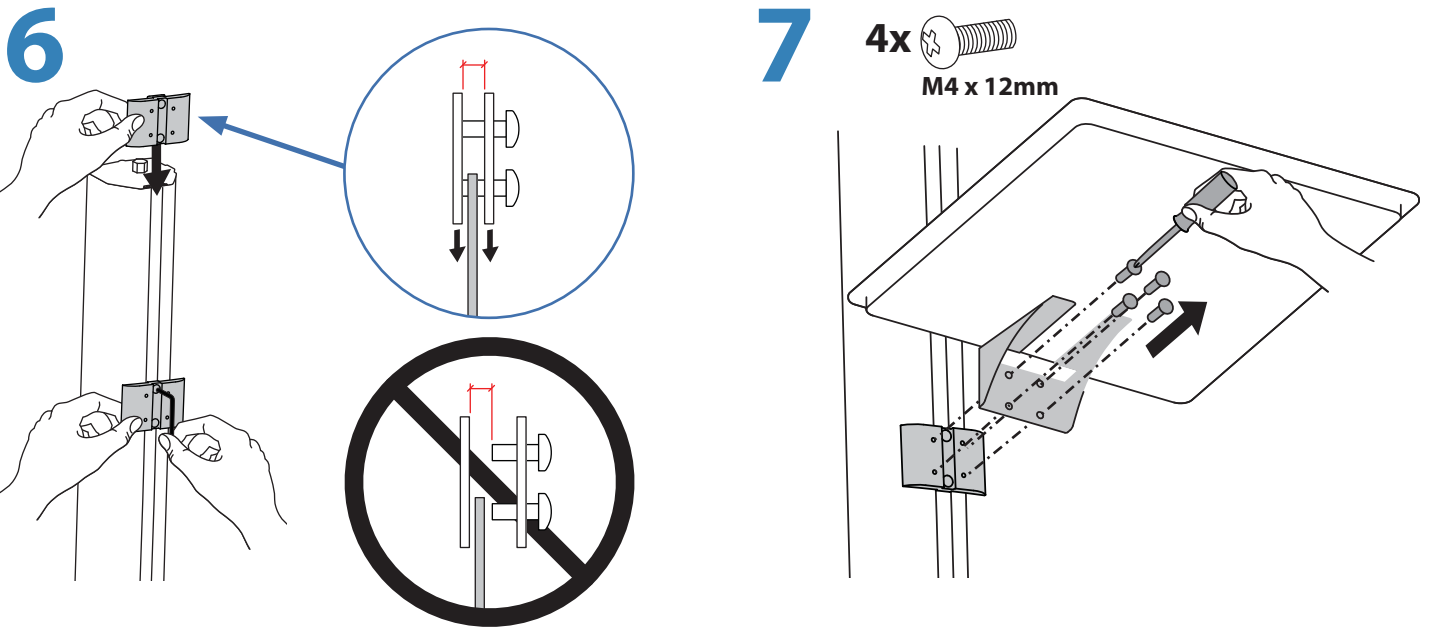
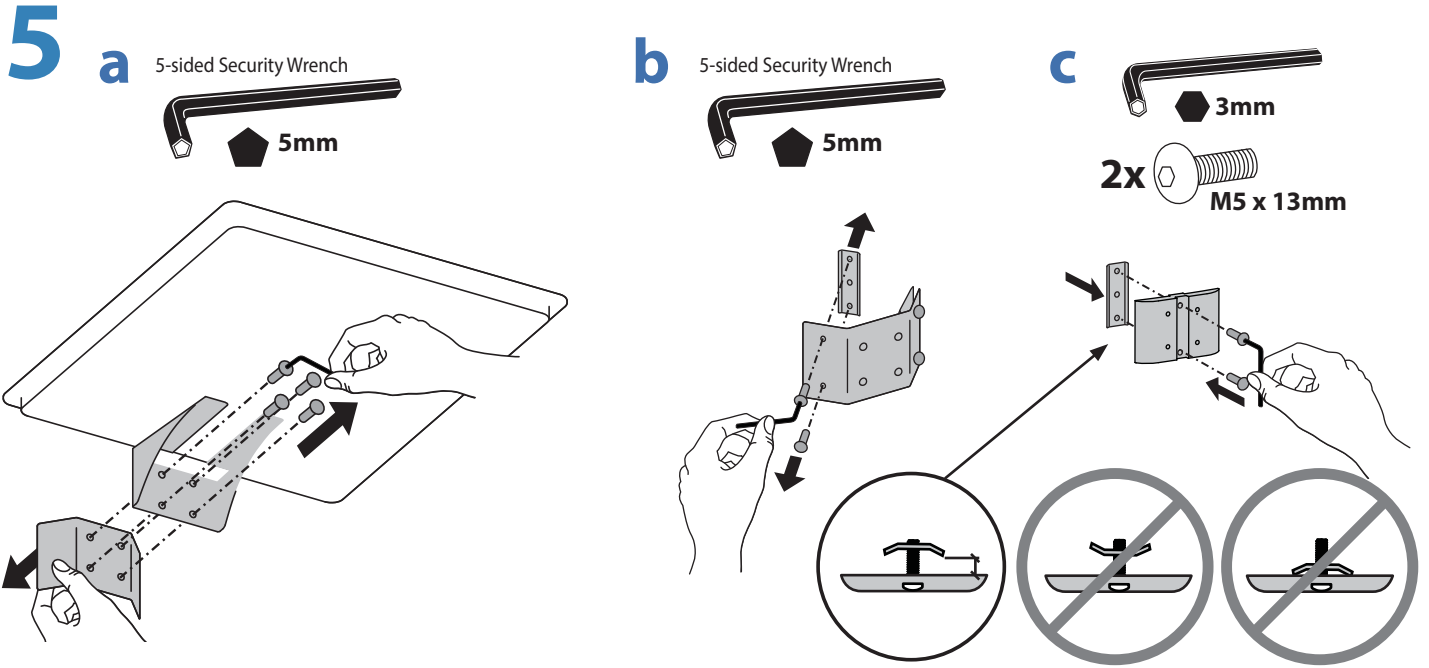

1 T-Slot

9

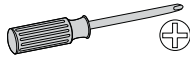
a 

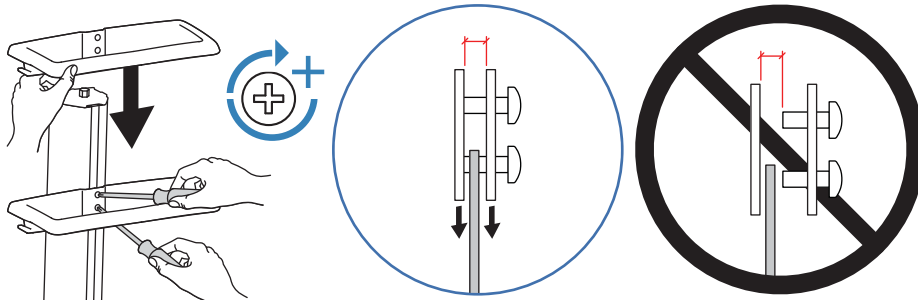

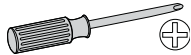
b 

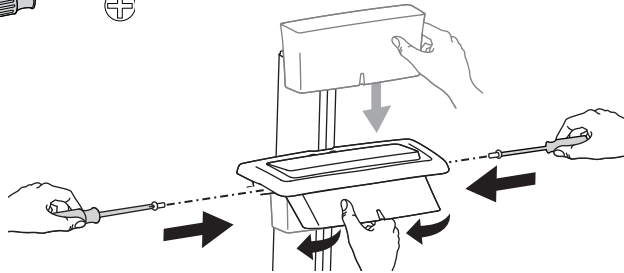

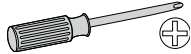
c 

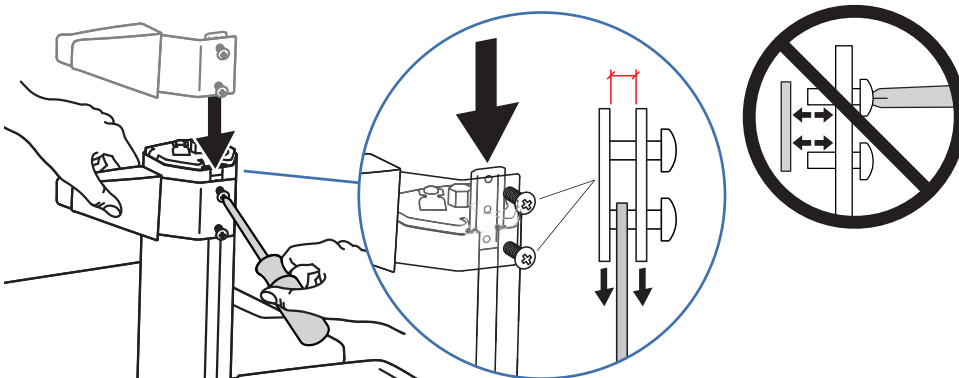

d

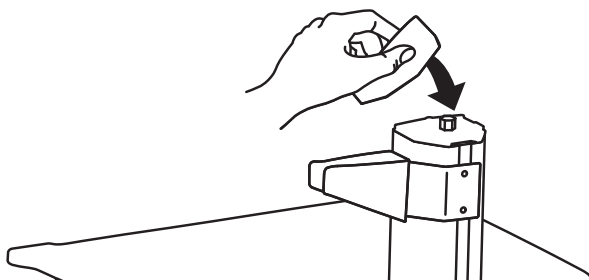

2 T-Slot

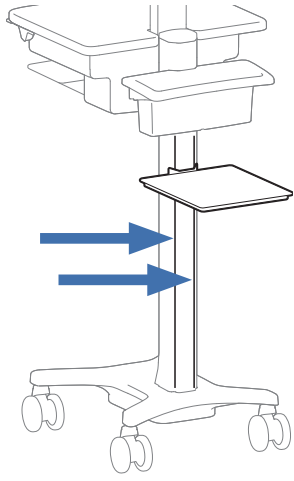

3

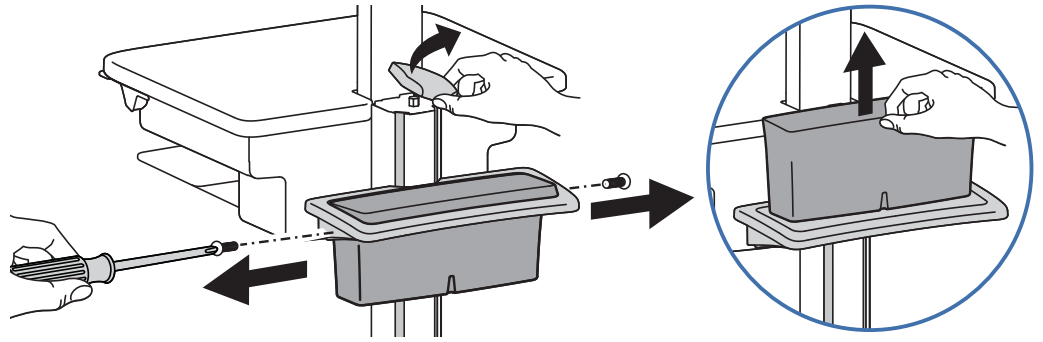

4

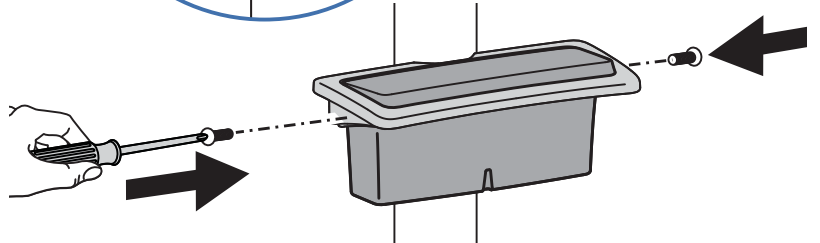
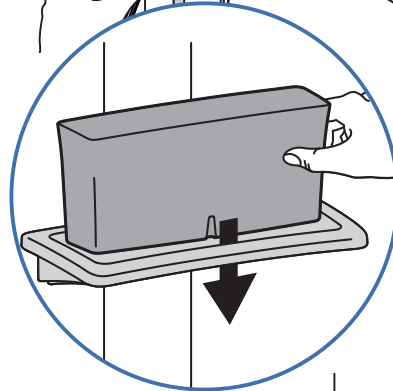
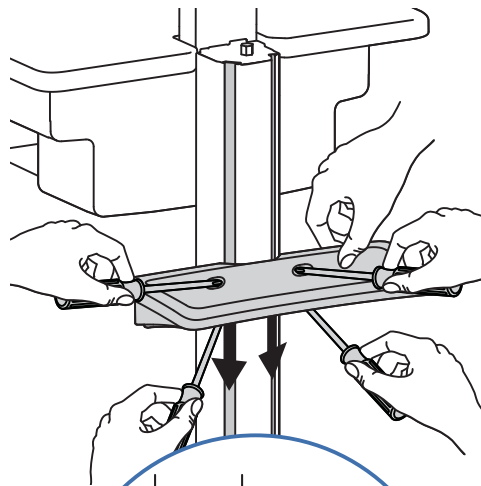
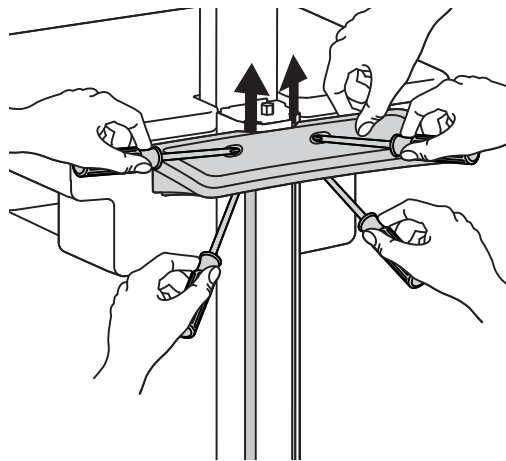
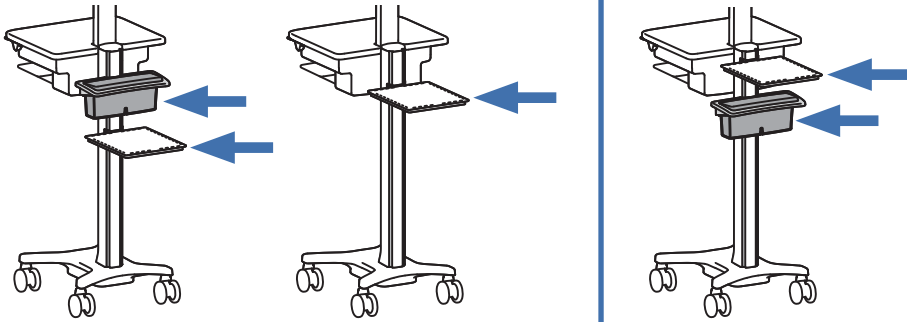

ENGLISH

2 T-Slot

5

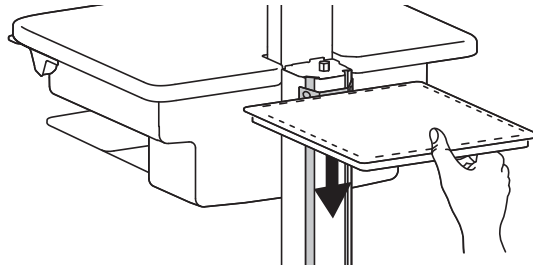

5-sided Security Wrench



5mm



4x

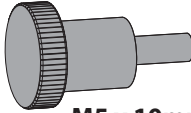

M5 x 10mm

1

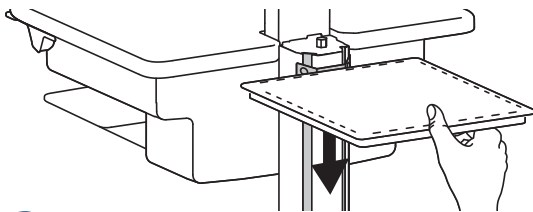

2

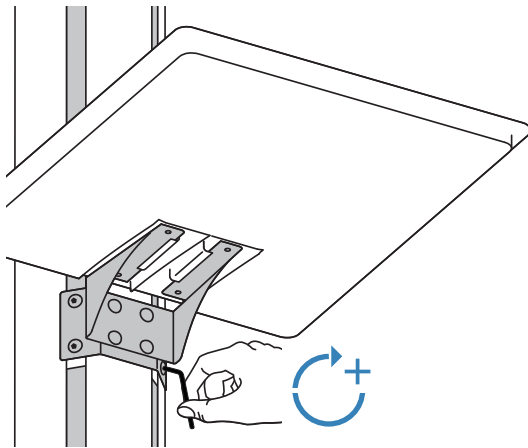

1

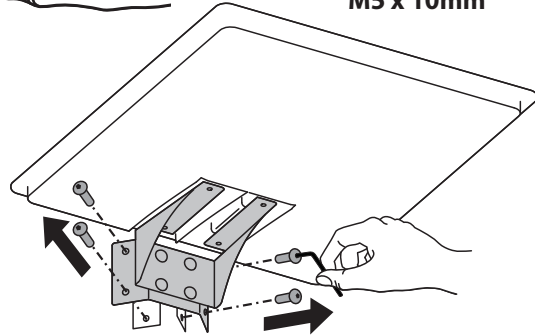

2

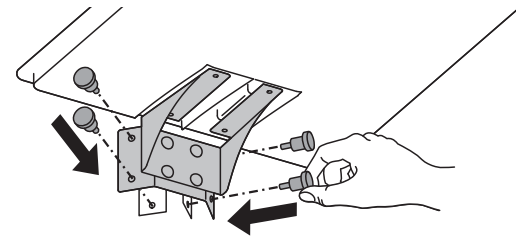

3

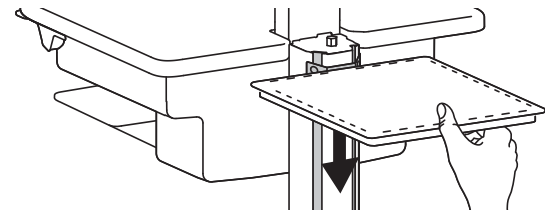

4

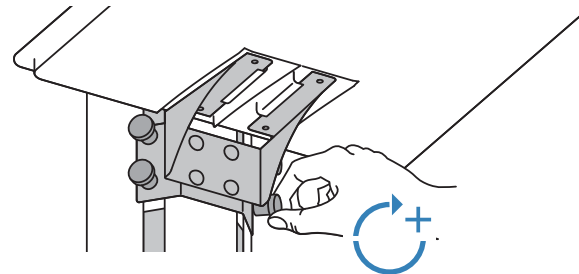

2 T-Slot

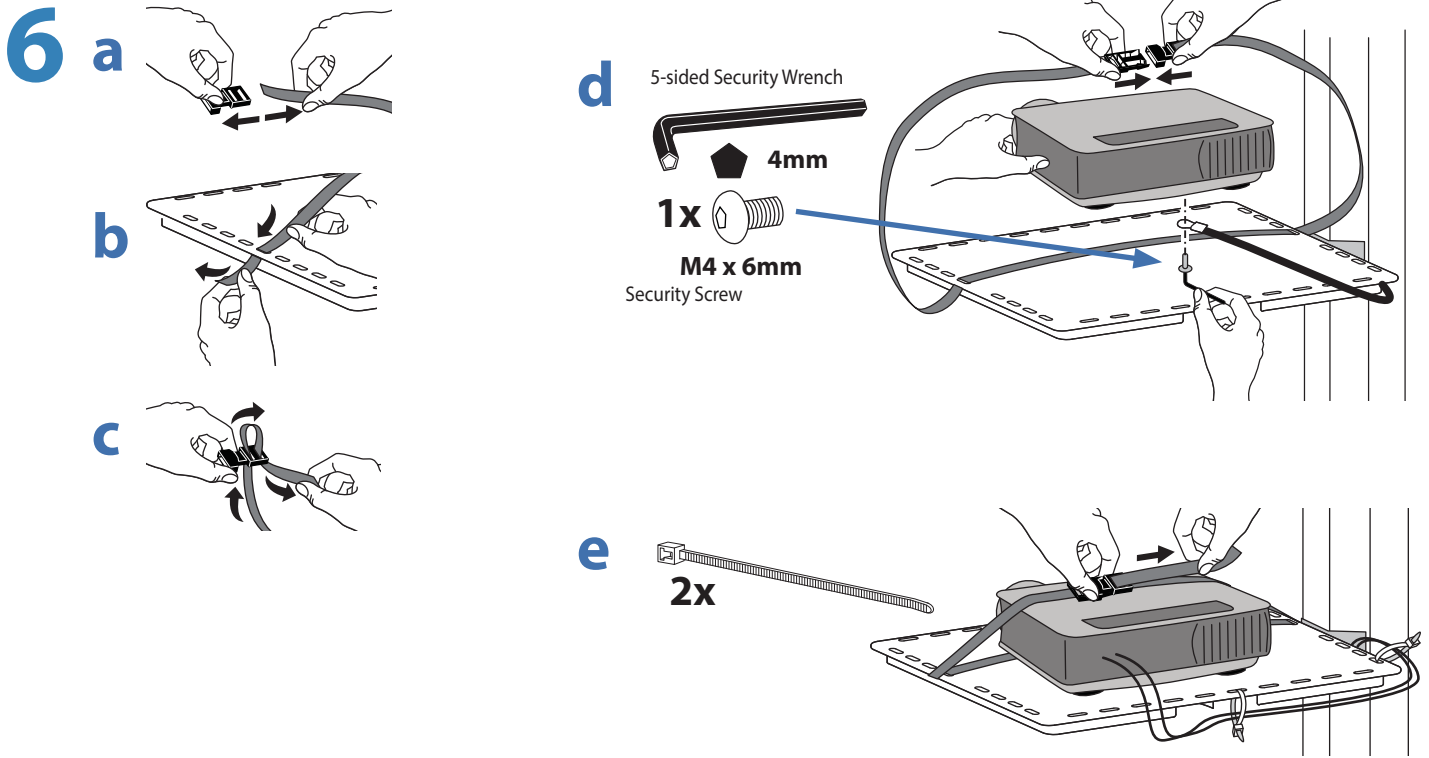

7

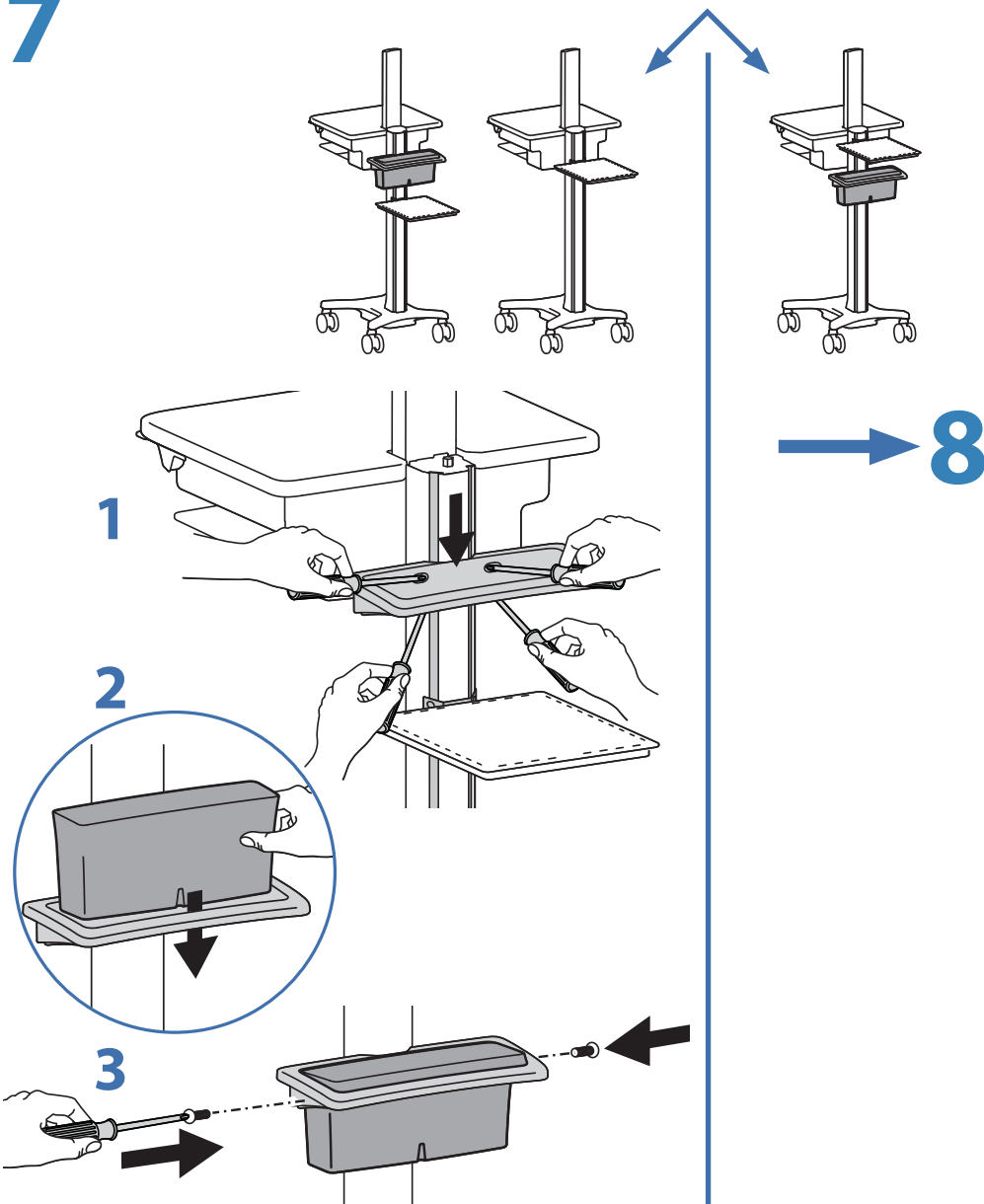

2 T-Slot

8

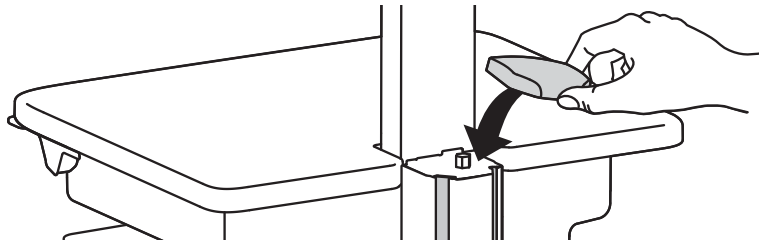

205 Westwood Ave, Long Branch, NJ 07740
Phone: 866-94 BOARDS (26273) / (732)-222-1511
Fax: (732)-222-7088 | E-mail: sales@touchboards.com

Service and Warranty

For service and warranty visit www.ergotron.com

For local customer care phone numbers visit: <http://contact.ergotron.com>

Americas Sales and Corporate Headquarters

1181 Trapp Rd.
St. Paul, MN USA
(800) 888-8458
+1-651-681-7600
www.ergotron.com
sales@ergotron.com

APAC Sales

Tokyo, Japan
www.ergotron.com
apaccustomerservice@ergotron.com

EMEA Sales

Amersfoort, The Netherlands
+31 33 45 45 600
www.ergotron.com
info.eu@ergotron.com

Worldwide OEM Sales

www.ergotron.com
info.oem@ergotron.com



© 2014 Ergotron, Inc.
All rights reserved.

While Ergotron, Inc. makes every effort to provide accurate and complete information on the installation and use of its products, it will not be held liable for any editorial errors or omissions (including those made in the process of translation from English to another language), or for incidental, special or consequential damages of any nature resulting from furnishing this instruction and performance of equipment in connection with this instruction. Ergotron, Inc. reserves the right to make changes in the product design and/or product documentation without notification to its users. For the most current product information, or to know if this document is available in languages other than those herein, please contact Ergotron. No part of this publication may be reproduced, stored in a retrieval system, or transmitted in any form or by any means, electronic, mechanical, photocopying, recording or otherwise without the prior written consent of Ergotron, Inc., 1181 Trapp Road, Eagan, Minnesota, 55121, USA. Patents Pending and Patented U.S. & Foreign. Ergotron is a registered trademark of Ergotron, Inc.