

Dual Monitor and Handle Kit

Dimensions

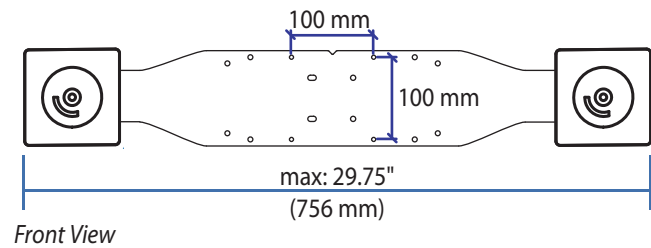

Front View

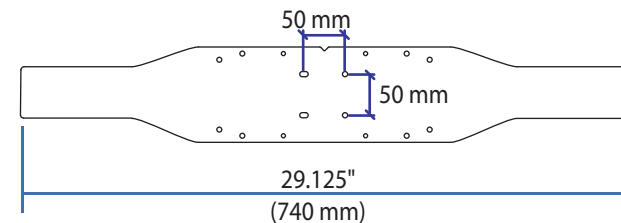

Front View

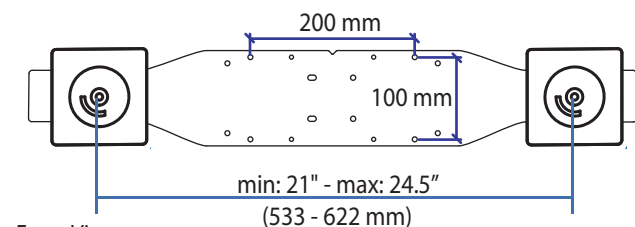

Front View

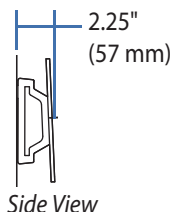

Side View

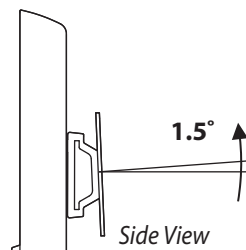

Side View

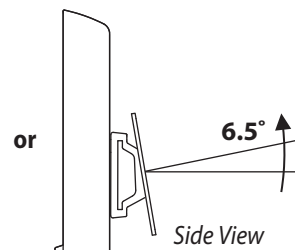

Side View

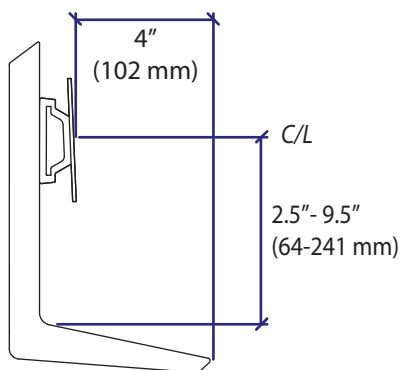

Side View

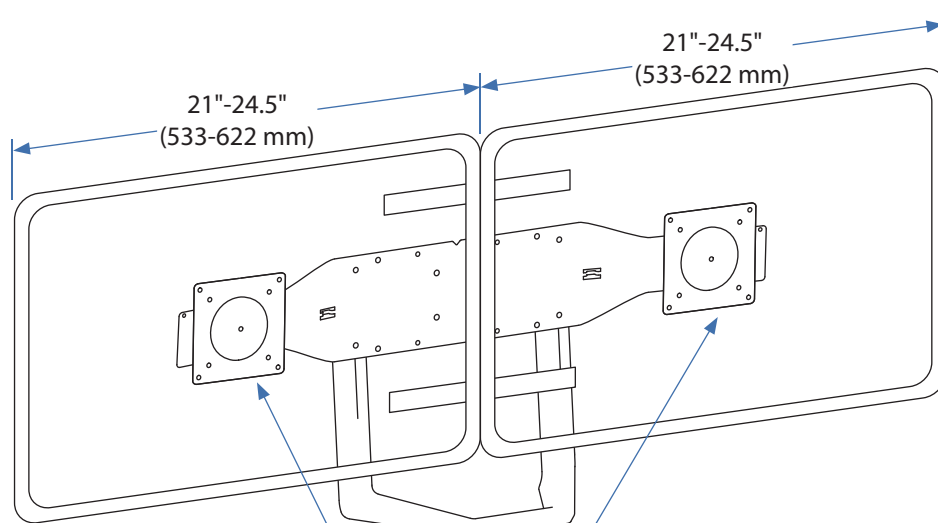

Range of Motion

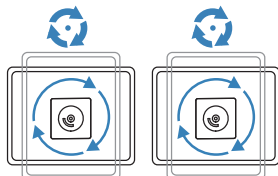

Front View

Weight Capacity

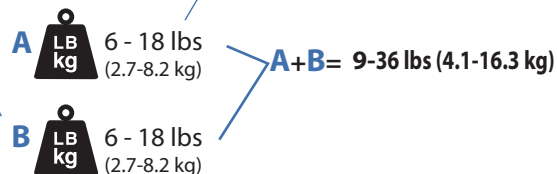

This product adds an additional 6 lbs (2.7 kg) to your mounting solution. Your mounting solution's monitor weight capacity must be reduced by 6 lbs (2.7 kg) when using standard monitors less than or equal to 2.5" (64 mm) thick. Additional reduction will be required if monitors are greater than 2.5" (64 mm) thick.