

For service and warranty visit www.ergotron.com
 Si desea información de servicio y garantía, visite www.ergotron.com
 Pour toute question concernant la garantie ou le service client, consultez www.ergotron.com
 Weitere Informationen zu Service und Gewährleistung erhalten Sie unter www.ergotron.com.
 Ga voor service en garantie naar www.ergotron.com
 Per assistenza e la garanzia visitare www.ergotron.com
 Gå in på www.ergotron.com för service och garanti
 サービスおよび保証について詳しくは、www.ergotron.com をご覧ください。
 有关服务和保修，请访问 www.ergotron.com

www.ergotron.com

User's Guide - English
 Guía del usuario - Español
 Manuel de l'utilisateur - Français
 Gebruikersgids - Nederlands
 Benutzerhandbuch - Deutsch
 Guida per l'utente - Italiano
 Användarhandbok - svenska
 ユーザーガイド : 日本語
 用户指南 : 汉语

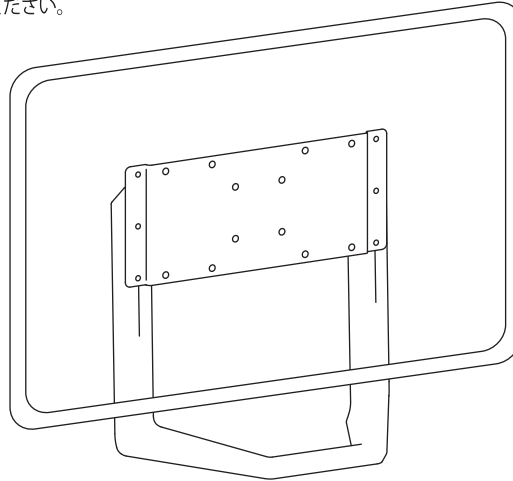

IMPORTANT! This product adds an additional 2.9 lbs. (1.3 kg) to your mounting solution. Your mounting solution's monitor weight capacity must be reduced by 2.9 lbs. (1.3 kg) when using standard monitors less than or equal to 2.5" (64 mm) thick. Additional reduction will be required if monitors are greater than 2.5" (64 mm) thick.



	A	B	C	D	E	D
1	1x 	1x 	4x M6-M8 x 5mm 	2x M6 x 30mm 		4x M4
2	1x 4 mm 		4x M6-M8 x 10mm 	4x ID: 5.2 mm OD: 13 mm THK: 2.5 mm 	4x ID: 8.5 mm OD: 18 mm THK: 2.5 mm 	2x ID: 6.5 mm OD: 12 mm THK: 1 mm
3	2x 	4x M4 x 10mm 				
4	4x M4 x 15mm 	4x M5 x 15mm 	4x M4 x 30mm 	4x M5 x 30mm 		
5	4x M6 x 15mm 	4x M8 x 15mm 	4x M6 x 30mm 	4x M8 x 30mm 		

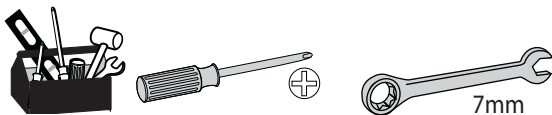

1 There are 5 ways to mount this product. Based on what mounting solution and display you are attaching this product to, follow the appropriate mounting instructions.

- A. Attach to mounting solution with 50 x 50 mm hole pattern and display with 100x100mm hole pattern.
- B. Attach to mounting solution with 50 x 50 mm hole pattern and display with 200x100mm hole pattern.
- C. Attach to mounting solution and display with 100 x 100 mm mounting hole pattern.
- D. Attach to mounting solution and display with 200 x 100 mm mounting hole pattern.
- E. Attach to mounting solution with 100 x 100 mm hole pattern and display with 200x100mm hole pattern.

A/B

50 mm
50 mm

100mm
100mm

200mm
100mm

4x !

Use the fasteners and tool supplied with your mounting solution.

50 mm
50 mm

Top view of attachment.

3

C

100 mm
100 mm

100mm
100mm

Top view of attachment.

4

D

200 mm
100 mm

200mm
100mm

Top view of attachment.

5

E

100 mm
100 mm

200mm
100mm

4x M4 x 10mm

4x M4

7mm

100 mm
100 mm

Top view of attachment.

6

A/B

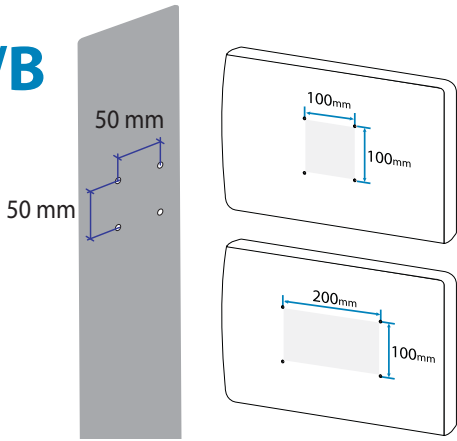

WARNING! PLEASE SELECT THE PROPER SCREW LENGTH AND WIDTH FOR YOUR FLAT PANEL BY HAND TIGHTENING TO CHECK YOUR FLAT PANELS THREAD WIDTH AND DEPTH.

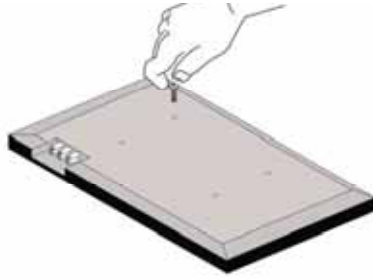

2

4x M4 x 15mm	4x M5 x 15mm	4x M4 x 30mm	4x M5 x 30mm
4x M6 x 15mm	4x M8 x 15mm	4x M6 x 30mm	4x M8 x 30mm
4x ID: 5.2 mm OD: 13 mm THK: 2.5 mm	4x ID: 8.5 mm OD: 18 mm THK: 2.5 mm	4x M6-M8 x 10mm	4x M6-M8 x 5mm

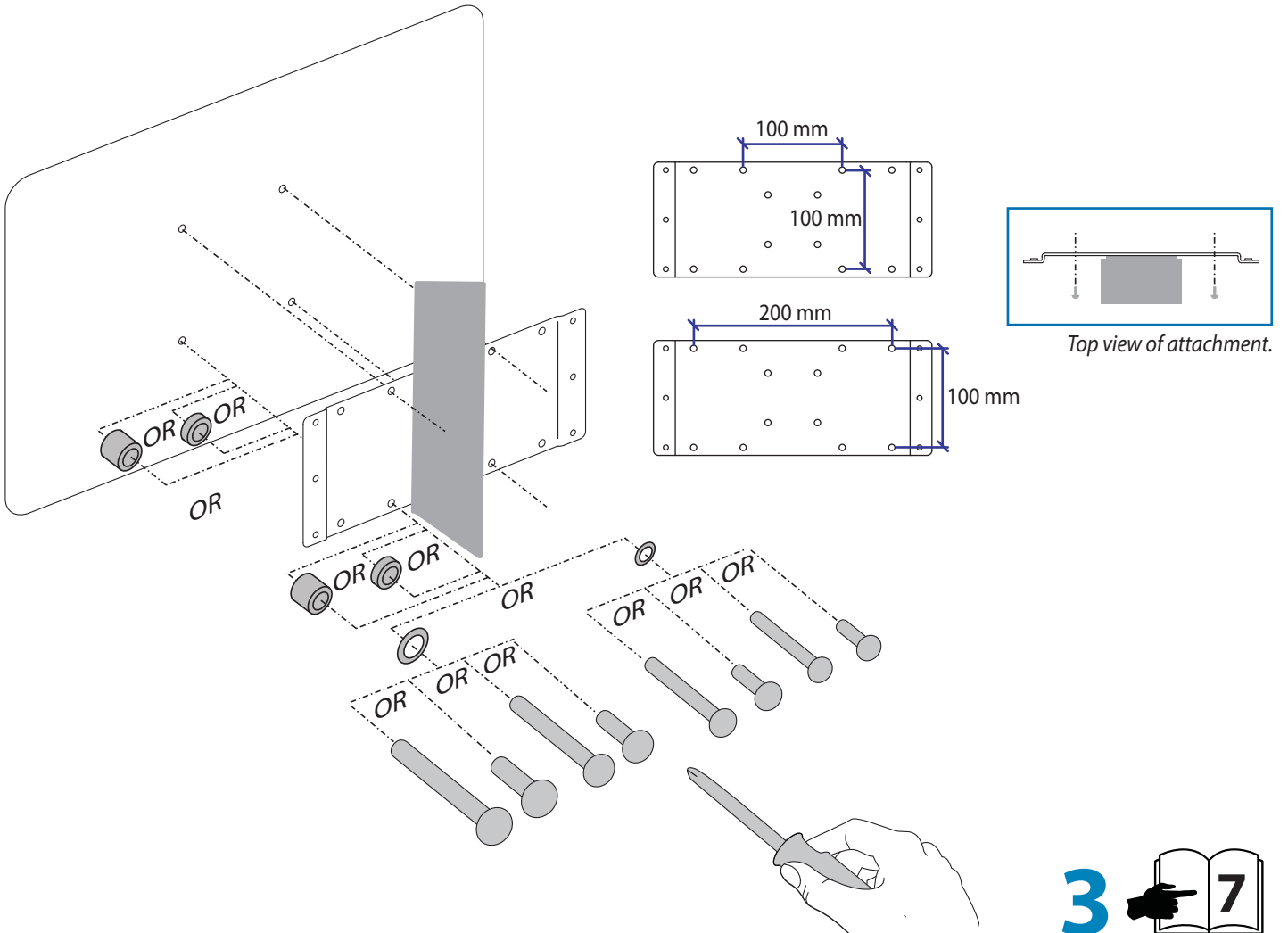

3 **7**

C

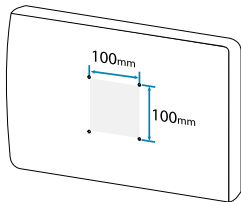
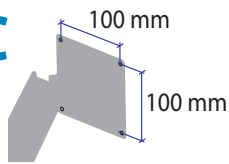

WARNING! PLEASE SELECT THE PROPER SCREW LENGTH AND WIDTH FOR YOUR FLAT PANEL BY HAND TIGHTENING TO CHECK YOUR FLAT PANELS THREAD WIDTH AND DEPTH.

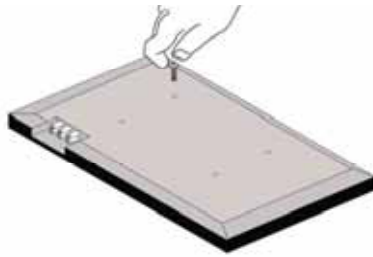

2

4x M4 x 15mm	4x M5 x 15mm	4x M4 x 30mm	4x M5 x 30mm
4x M6 x 15mm	4x M8 x 15mm	4x M6 x 30mm	4x M8 x 30mm
4x 	4x 	4x 	4x

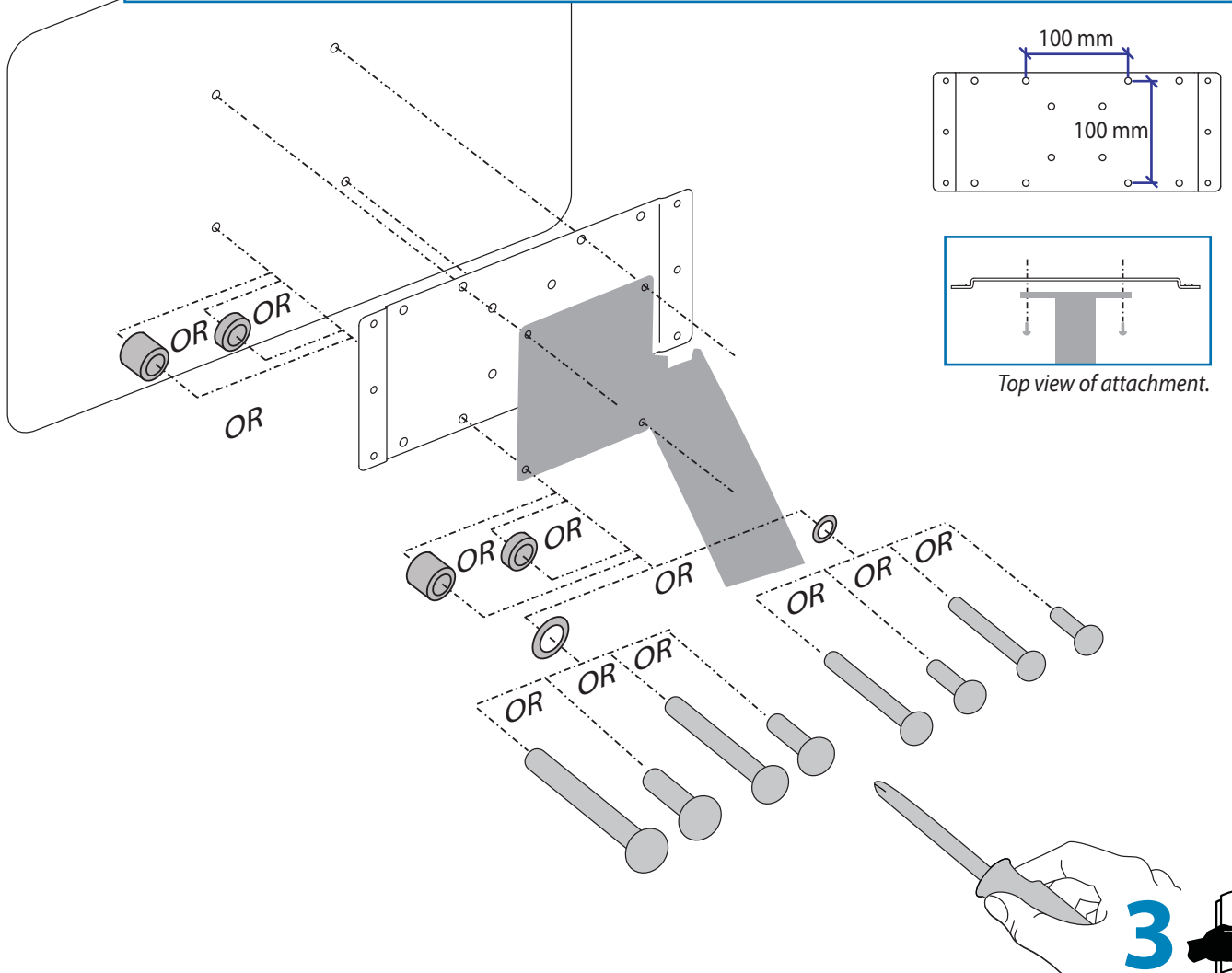

3

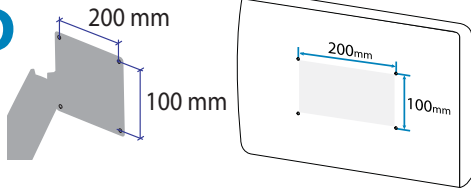
D

WARNING! PLEASE SELECT THE PROPER SCREW LENGTH AND WIDTH FOR YOUR FLAT PANEL BY HAND TIGHTENING TO CHECK YOUR FLAT PANELS THREAD WIDTH AND DEPTH.

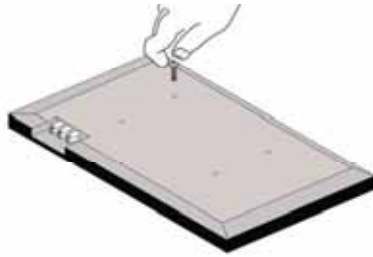
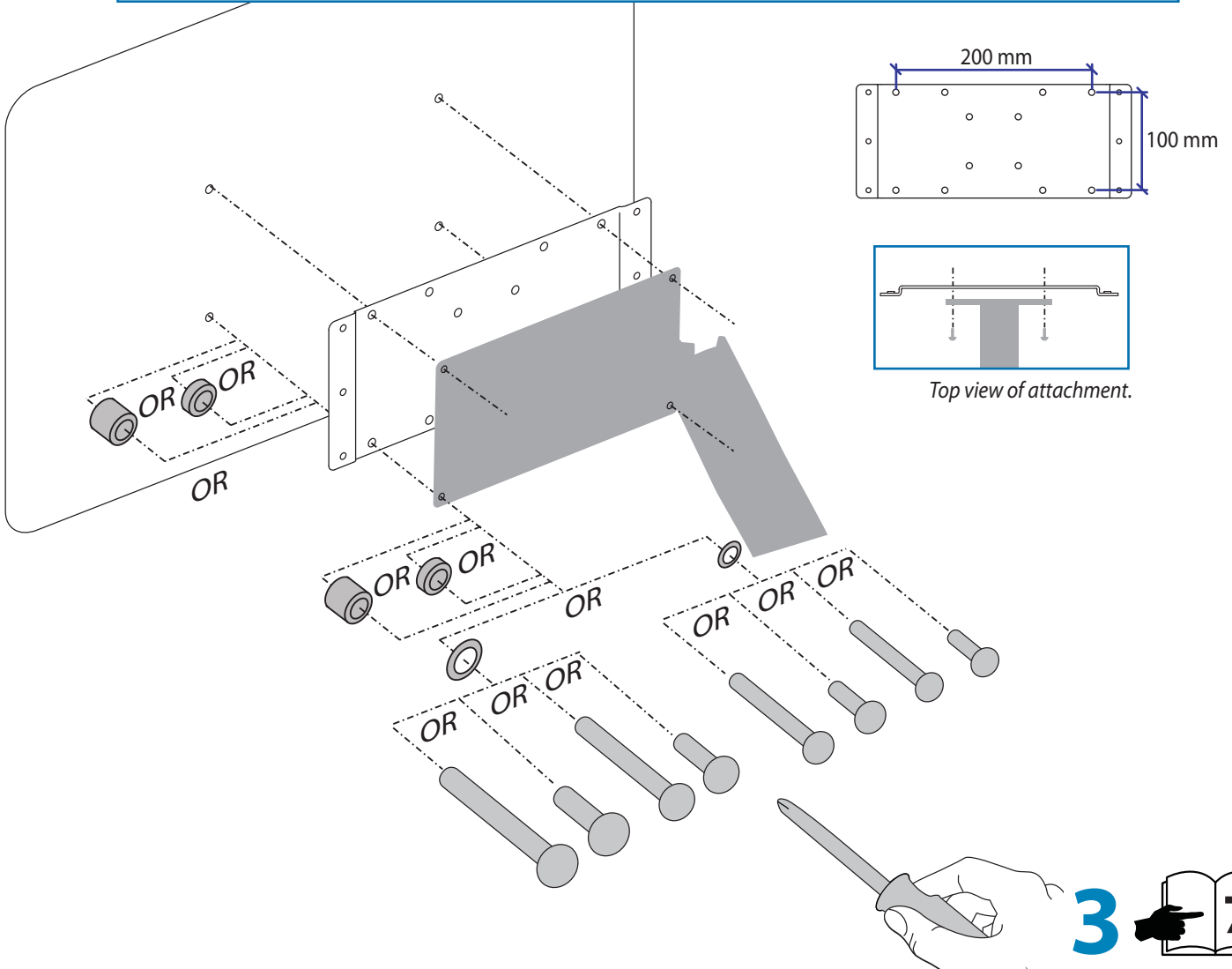
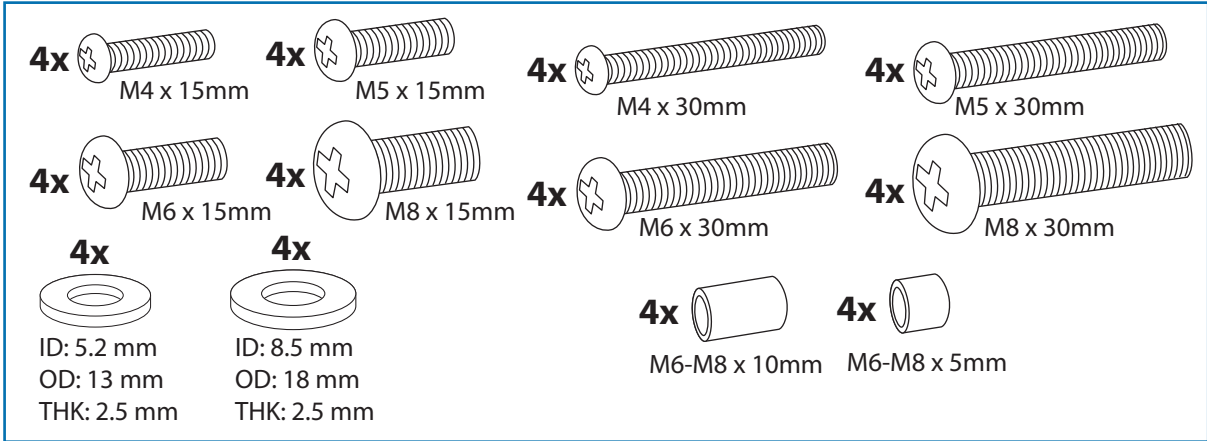
**2****3**

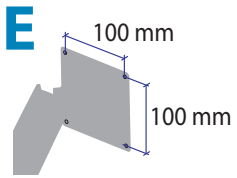

WARNING! PLEASE SELECT THE PROPER SCREW LENGTH AND WIDTH FOR YOUR FLAT PANEL BY HAND TIGHTENING TO CHECK YOUR FLAT PANELS THREAD WIDTH AND DEPTH.

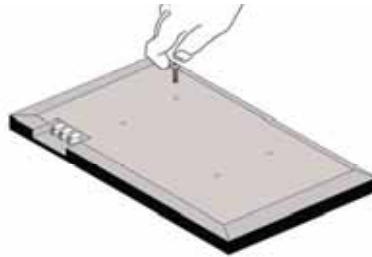

2

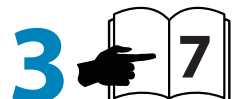
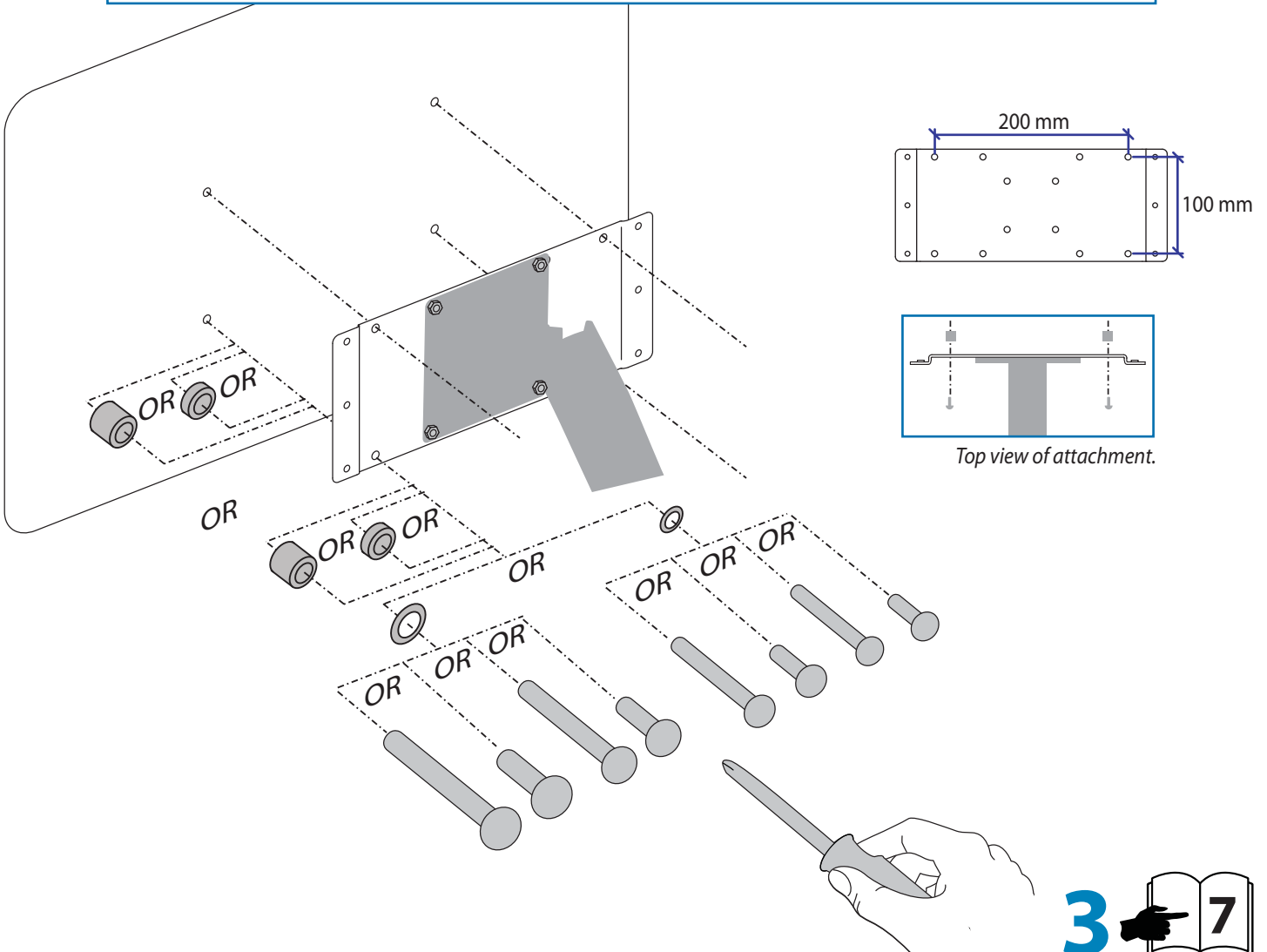
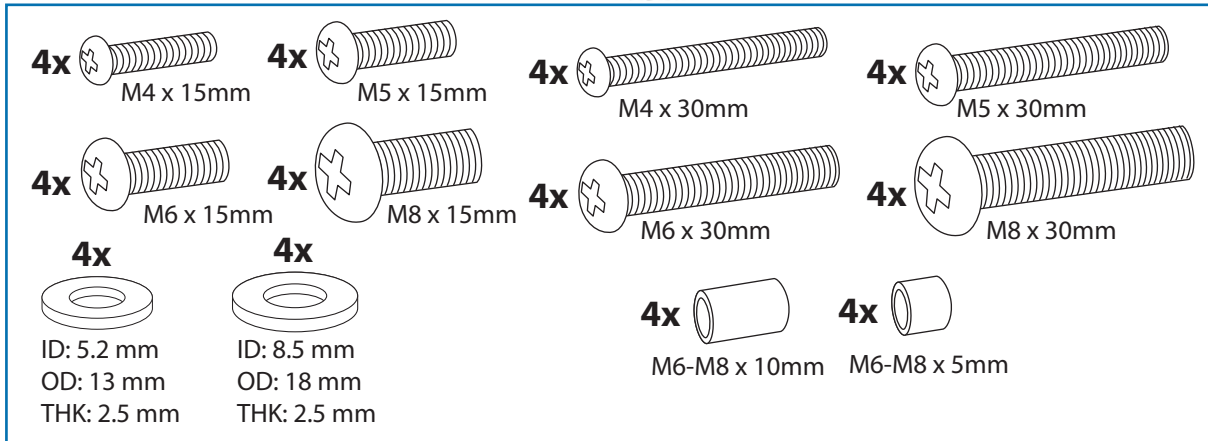

3

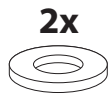
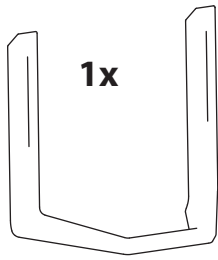

ID: 6.5 mm
OD: 12 mm
THK: 1 mm

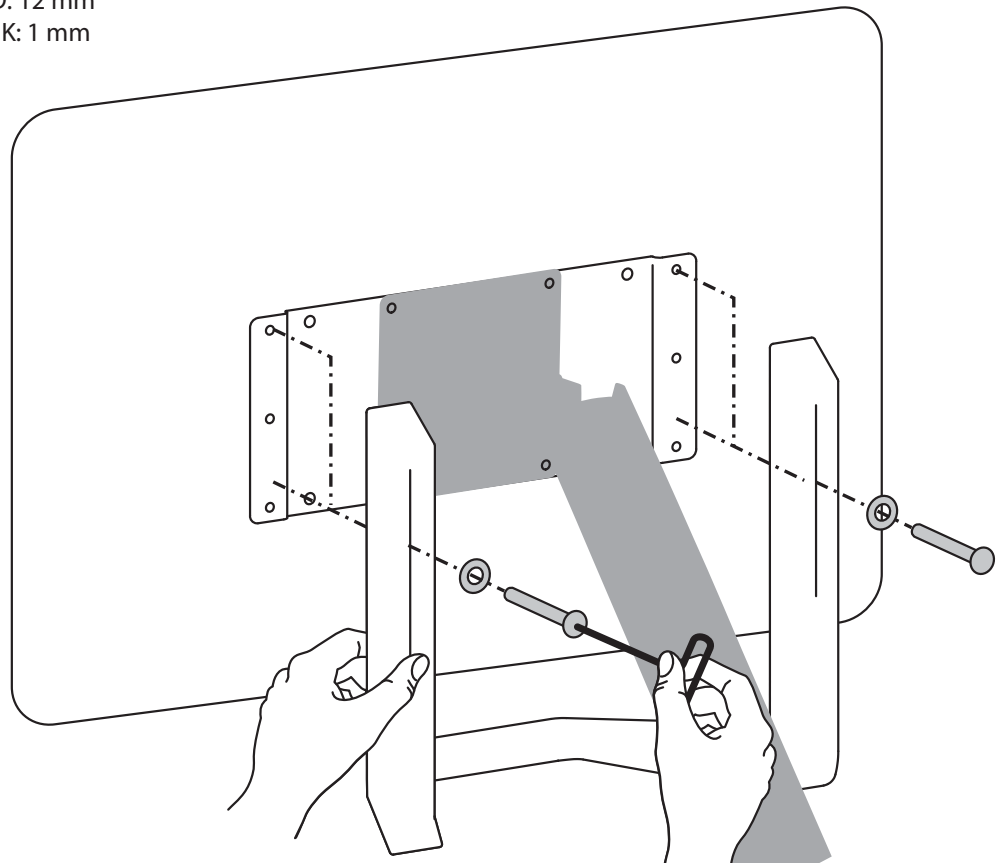
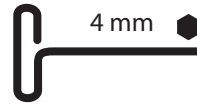
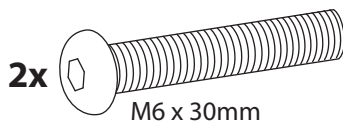

4



Adjustment · Ajuste · Réglage · Einstellung · Instellen · Regolazione · 調整 · 조절

Important! Adjust your mounting solution to handle the added weight.

You will need to adjust your product after installation is complete. Make sure all your equipment is properly installed on the product before attempting adjustments. Your mounting solution should move smoothly and easily through the full range of motion and stay where you set it. If movements are too easy or difficult or if product does not stay in desired positions, follow the adjustment instructions that came with your mounting solution to create smooth and easy movements. Depending on your product and the adjustment, it may take many turns to notice a difference. Any time equipment is added or removed from your mounting solution, resulting in a change in the weight of the mounted load, you should repeat the adjustment steps to ensure safe and optimum operation.



© 2013 Ergotron, Inc.
All rights reserved.

While Ergotron, Inc. makes every effort to provide accurate and complete information on the installation and use of its products, it will not be held liable for any editorial errors or omissions (including those made in the process of translation from English to another language), or for incidental, special or consequential damages of any nature resulting from furnishing this instruction and performance of equipment in connection with this instruction. Ergotron, Inc. reserves the right to make changes in the product design and/or product documentation without notification to its users. For the most current product information, or to know if this document is available in languages other than those herein, please contact Ergotron. No part of this publication may be reproduced, stored in a retrieval system, or transmitted in any form or by any means, electronic, mechanical, photocopying, recording or otherwise without the prior written consent of Ergotron, Inc., 1181 Trapp Road, Eagan, Minnesota, 55121, USA Patents Pending and Patented U.S. & Foreign. Ergotron is a registered trademark of Ergotron, Inc.

Touchboards

205 Westwood Ave, Long Branch, NJ 07740
Phone: 866-94 BOARDS (26273) / (732)-222-1511
Fax: (732)-222-7088 | E-mail: sales@touchboards.com