



Tablet Management Wall Mount 10 for iPad®

ENGLISH

Touchboards

205 Westwood Ave, Long Branch, NJ 07740
Phone: 866-94 BOARDS (26273) / (732)-222-1511
Fax: (732)-222-7088 | E-mail: sales@touchboards.com

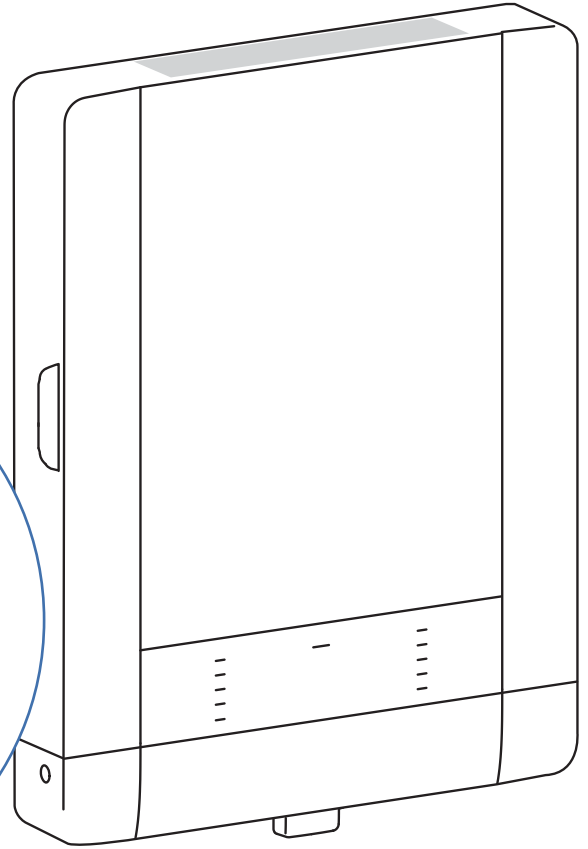
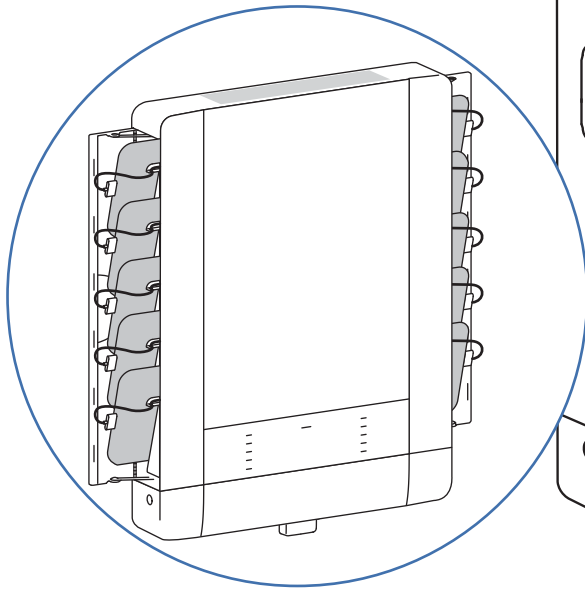

Includes Show & Stow™ technology.



≤ 24lbs. (11 kg)

CAUTION: DO NOT EXCEED MAXIMUM LISTED WEIGHT CAPACITY. SERIOUS INJURY OR PROPERTY DAMAGE MAY OCCUR!

Table of Contents

- Hazard Symbols Review & Safety2
- Components & Tools2
- Mounting Considerations3
- Set-up3 - 8
 - Wood Stud Attachment4
 - Concrete Attachment6
- Charging and Syncing10 - 11
- Cleaning and Maintenance12
- Specifications13
- Service and Warranty Information13

For service and warranty visit www.ergotron.com

Apple, iPad, iPad Air, iPad mini, Retina, iTunes, Lightning and Macintosh are trademarks of Apple Inc., registered in the U.S. and other countries.

"Made for iPad" means that an electronic accessory has been designed to connect specifically to iPad, and has been certified by the developer to meet Apple performance standards. Apple is not responsible for the operation of this device or its compliance with safety and regulatory standards. Please note that the use of this accessory with iPad may affect wireless.



Reduce.Reuse.Recycle

Hazard Symbols Review

These symbols alert users of a safety condition that demands attention. All users should be able to recognize and understand the significance of the following Safety Hazards if encountered on the product or within the documentation. Children who are not able to recognize and respond appropriately to Safety Alerts should not use this product without adult supervision!

Symbol	Signal Word	Level of Hazard
	NOTE	A NOTE indicates important information that helps you make better use of this product.
	CAUTION	A CAUTION indicates either potential damage to hardware or loss of data and tells you how to avoid the problem.
	WARNING	A WARNING indicates either potential for property damage, personal injury, or death.
	ELECTRICAL	An Electrical indicates an impending electrical hazard which, if not avoided, may result in personal injury, fire and/or death.

Safety



WARNING: Because surfaces vary widely and the ultimate mounting method is out of Ergotron's control, it is imperative that you consult with appropriate engineering, architectural or construction professional to ensure that your Ergotron mounting solution is mounted properly to handle applied loads.



CAUTION: Make sure the wall mount bracket is level, flush and snug to the wall surface. **DO NOT OVERTIGHTEN THE BOLTS.**

Components

	A	B	C	D
1	1x	1x		5x
2		1x	1x	5x
3	4x	1x	1x	4x
		5/32\"	1x	2x
				2x
				2x



Tools Needed

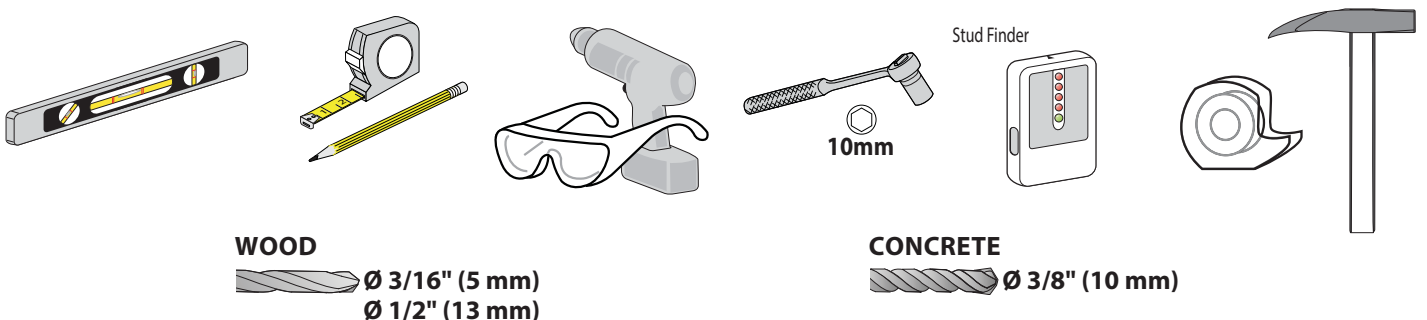

1 Mounting Considerations

Space Requirements:

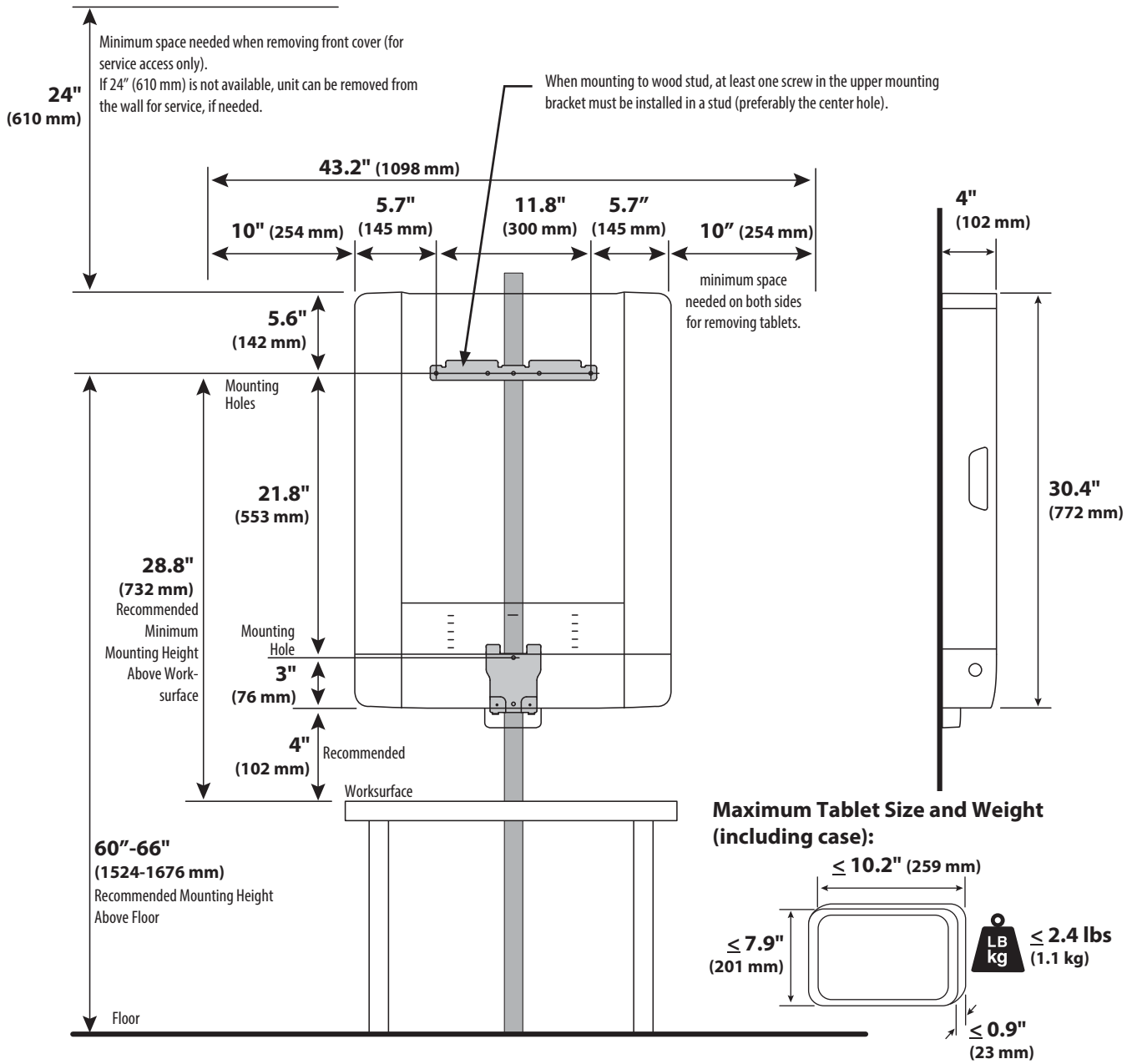

2

WOOD AND HOLLOW WALL

CONCRETE

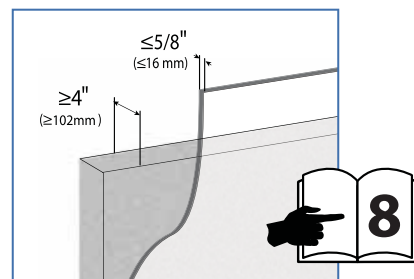
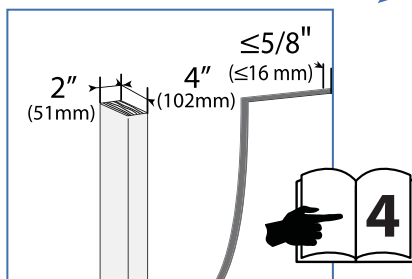

2 WOOD AND HOLLOW WALL

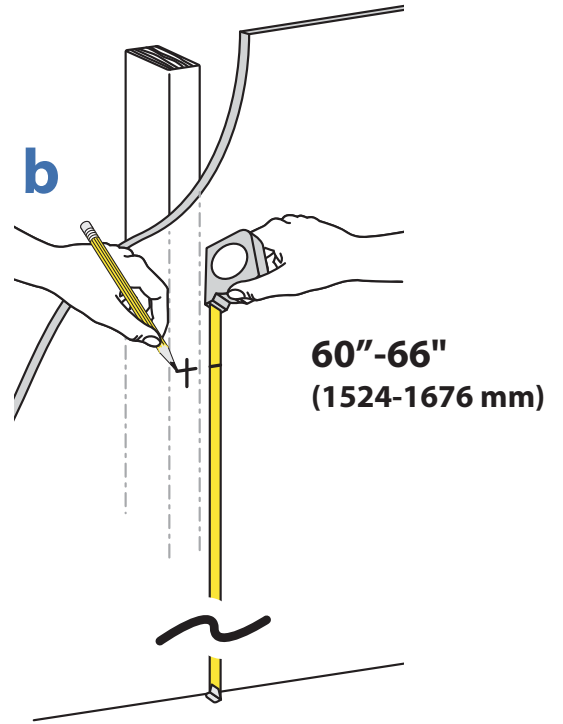
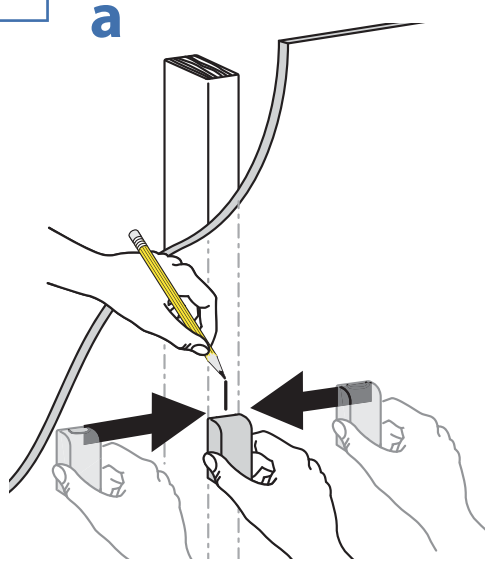
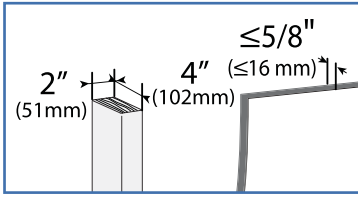

c



NOTE: The stud can be located at one of five mounting holes on the top bracket. While the first option (center hole of bracket) is recommended for most cases, you should consult with a construction professional to confirm which method is best suited for your particular situation. Options 2-5 are illustrated on the following page in no order of preference.

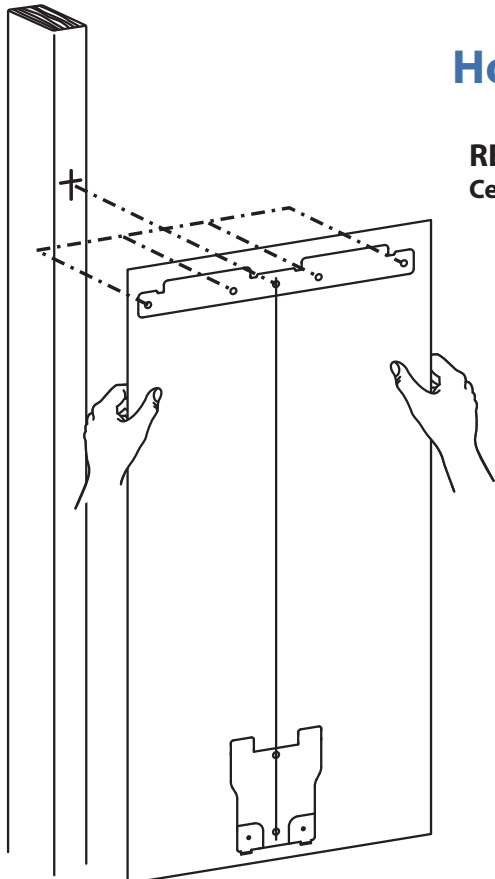

Hole Option 1

RECOMMENDED
Center Hole in Stud

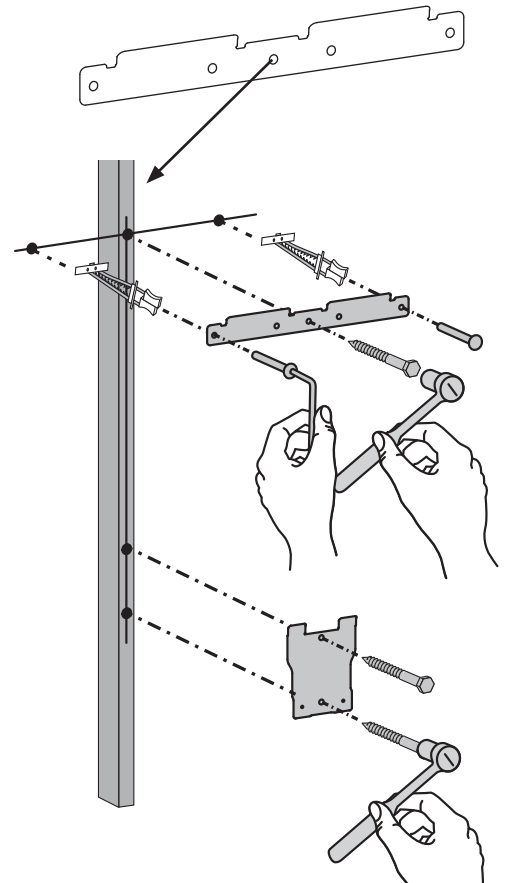

STUD LOCATION OPTIONS 2-5

Hole Option 2

Extreme Left Hole in Stud

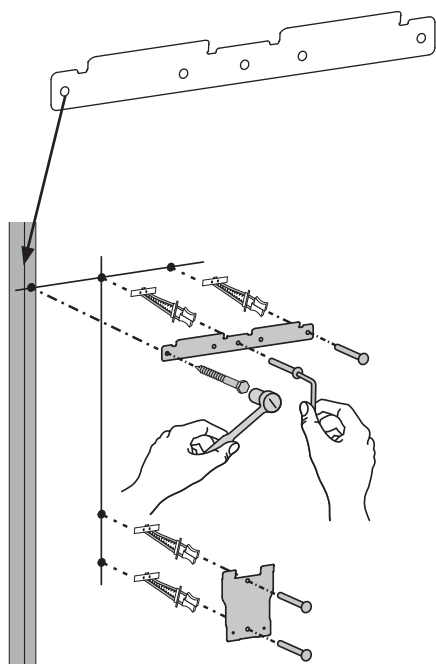

Hole Option 3

Extreme Right Hole in Stud

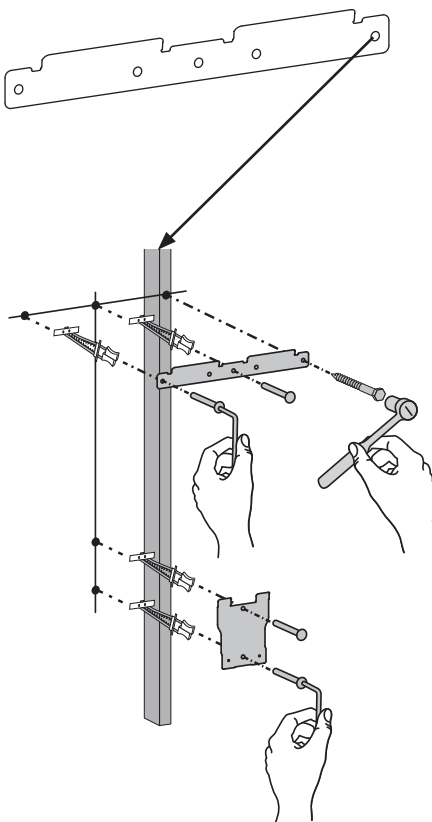

Hole Option 4

Middle Right Hole in Stud

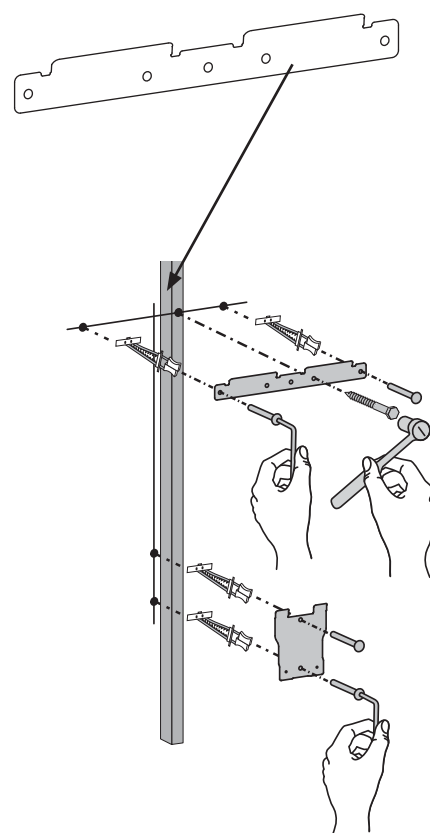

Hole Option 5

Middle Left Hole in Stud

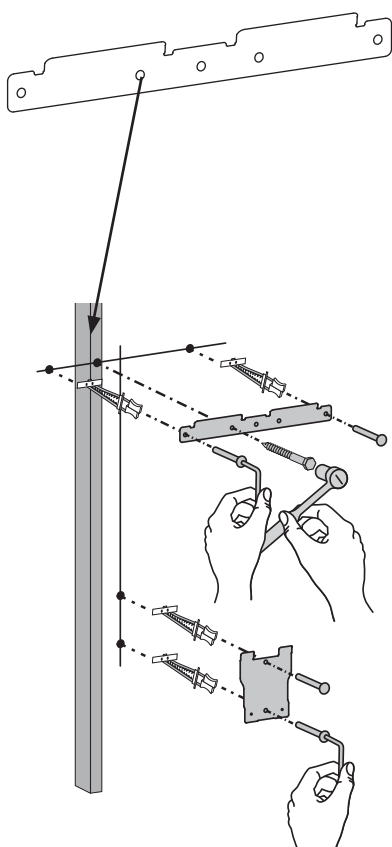

d

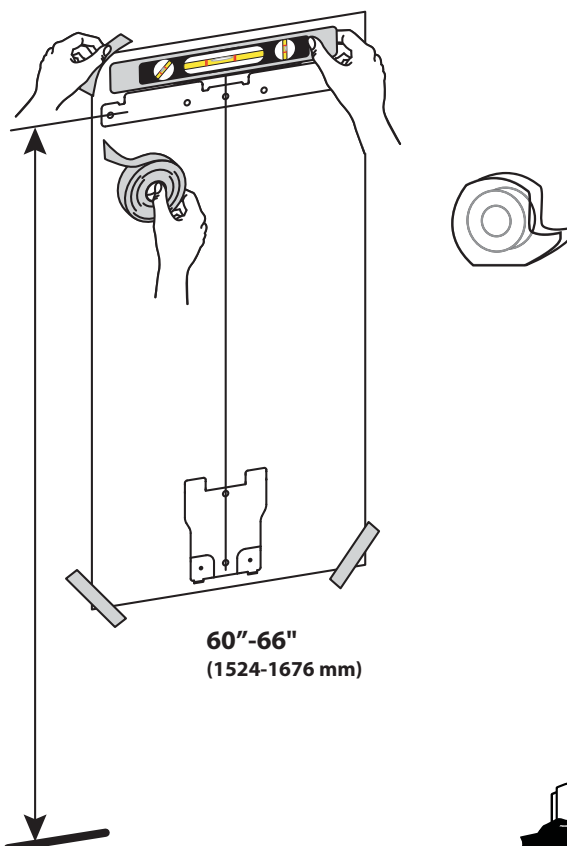

WOOD AND HOLLOW WALL

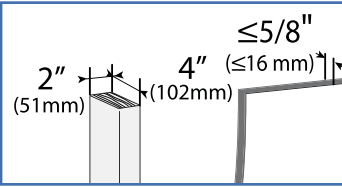

e Drill the three holes in the top bracket that correspond with the hole option determined on previous page. Then drill the two holes in the bottom bracket.



NOTE: Use the $\text{Ø } 3/16''$ (5 mm) drill bit when drilling directly into the wood stud. Use the $\text{Ø } 1/2''$ (13 mm) drill bit when drilling into the hollow wall for the anchors. Use hollow wall anchors where ever a screw does not get inserted directly into the wood stud.



NOTE: Bottom Bracket mounting holes will always line up vertically with the center mounting hole in the Top Bracket.

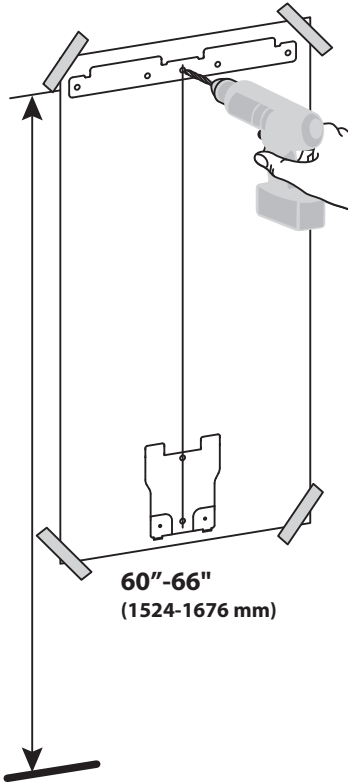

WOOD STUD

$\text{Ø } 3/16''$ (5 mm)

M6 x 70mm

HOLLOW WALL

$\text{Ø } 1/2''$ (13 mm)

1x $5/32''$

$1/4'' - 20 \times 2''$

1. Insert anchor into hole.
2. Push anchor into wall.
3. Push bracket over anchor.
4. Tighten screw to secure bracket.

f

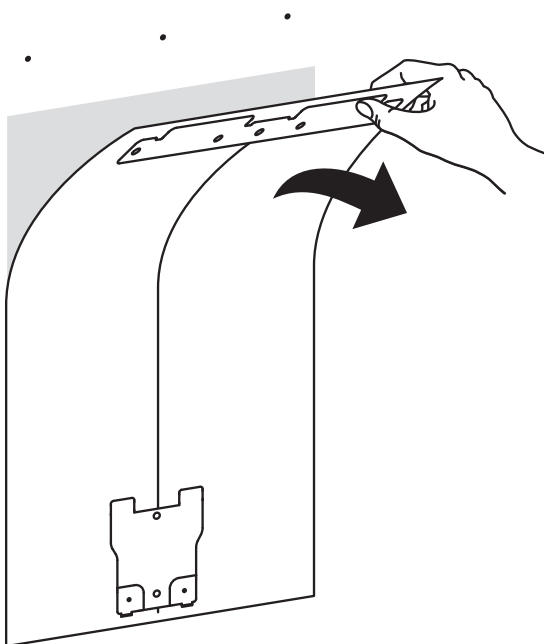

g

Attach brackets to wall according to the hole option determined on previous page.

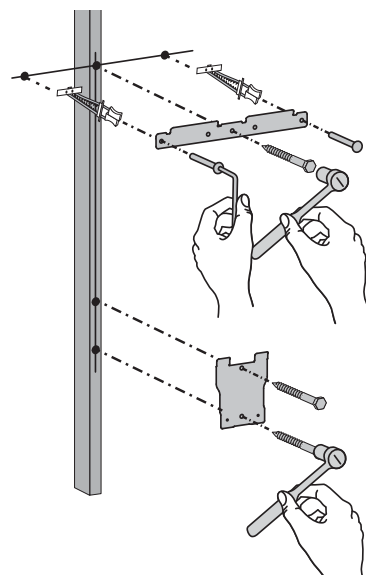

CONCRETE

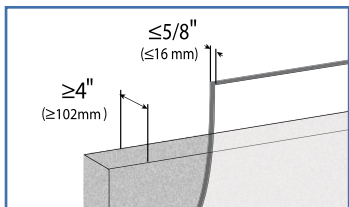

a

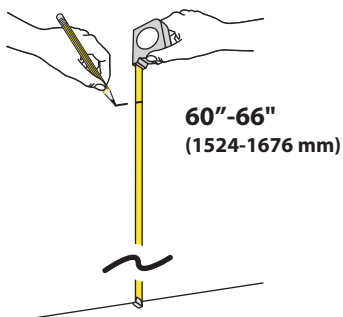

b

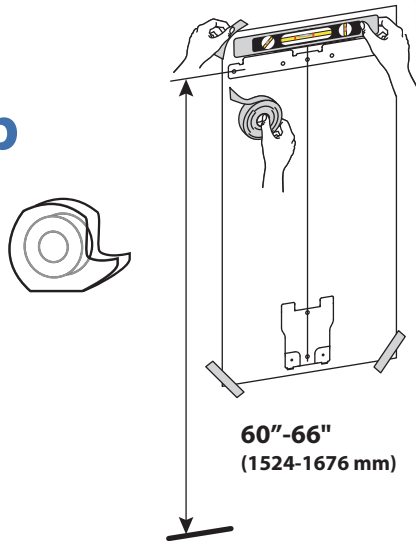

c

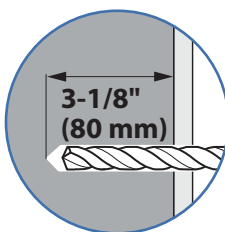
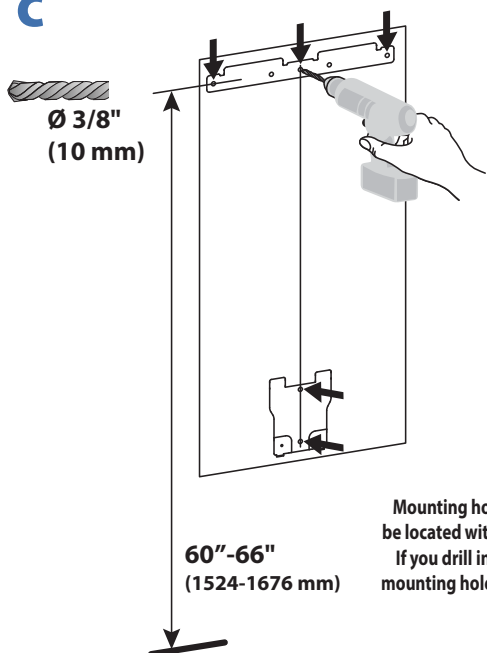

WARNING:

Mounting holes must be at least 3-1/8" (80mm) deep and must be located within solid concrete, not mortar or covering material. If you drill into an area of concrete that is not solid, reposition mounting holes until both anchors can be fully inserted into solid concrete!

d

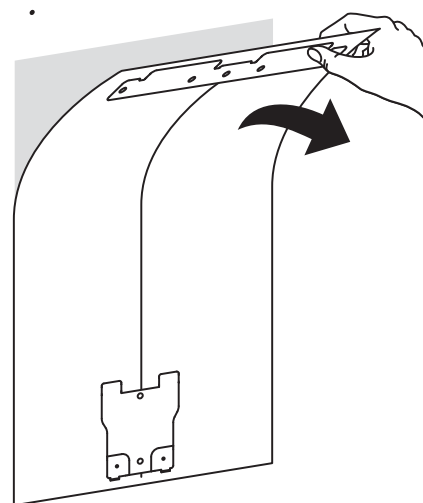

e

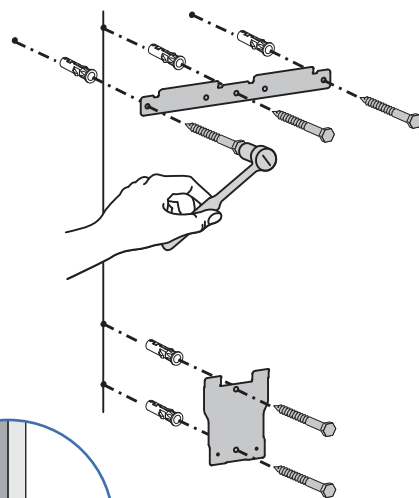
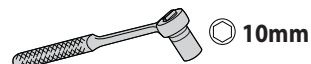
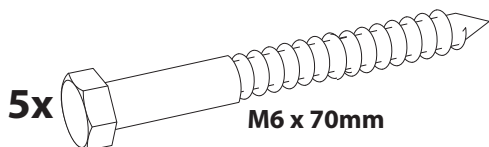
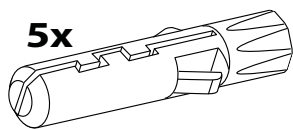

WARNING:

Anchors that are not fully set in solid concrete will not support the applied load resulting in an unstable, unsafe condition which could lead to personal injury and/or property damage. Consult a construction professional if you have any doubt about what this means in regard to your particular situation.

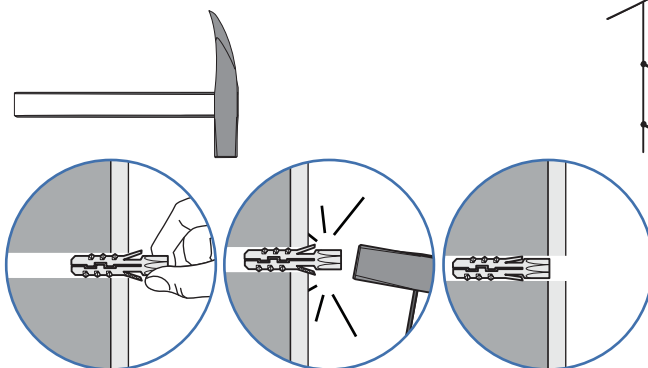

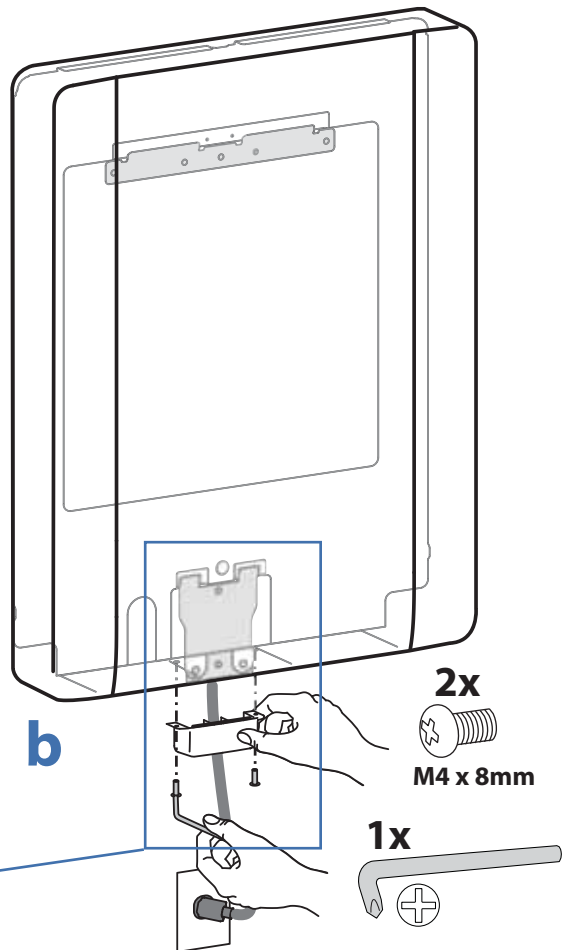
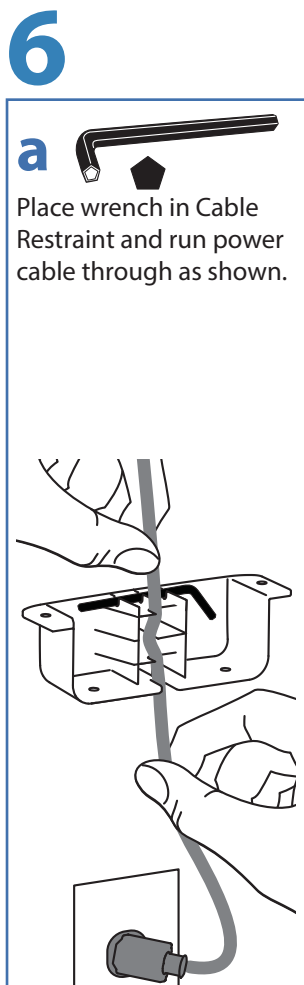
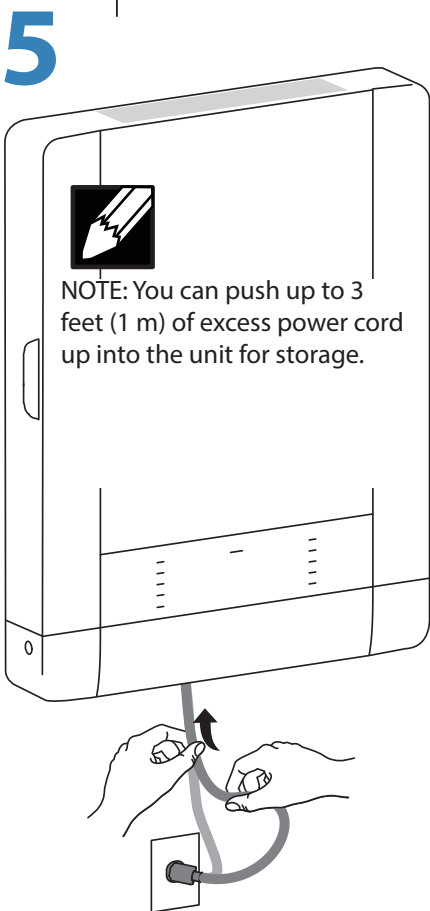
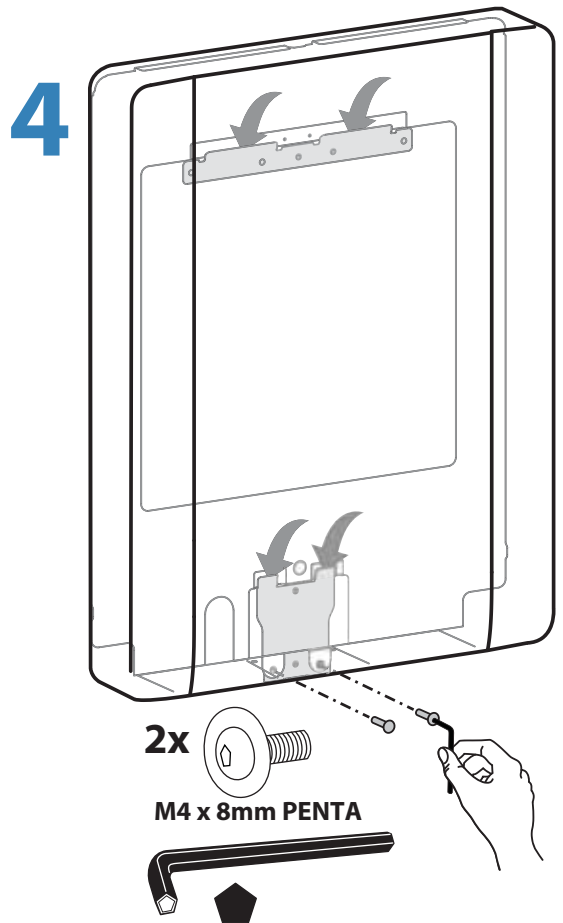
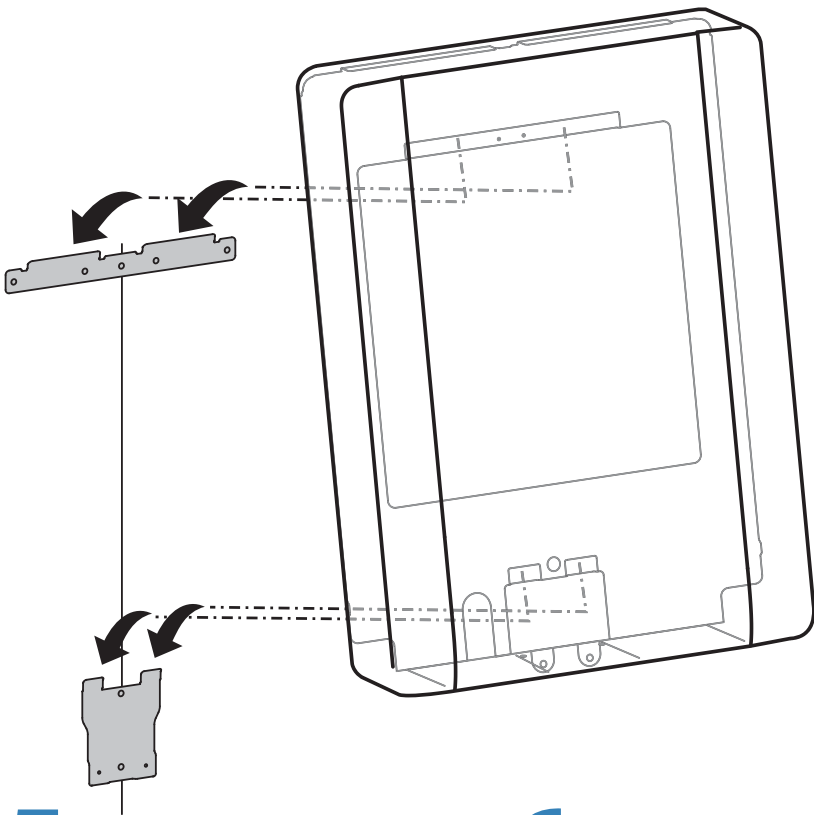
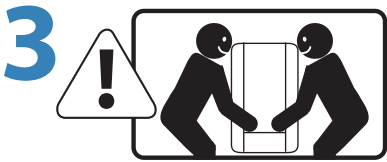

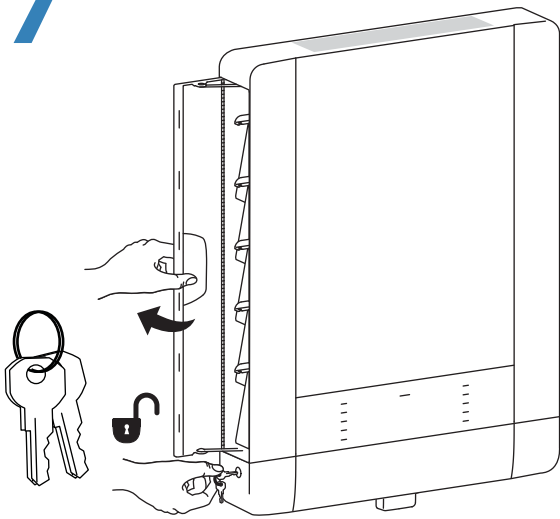

7

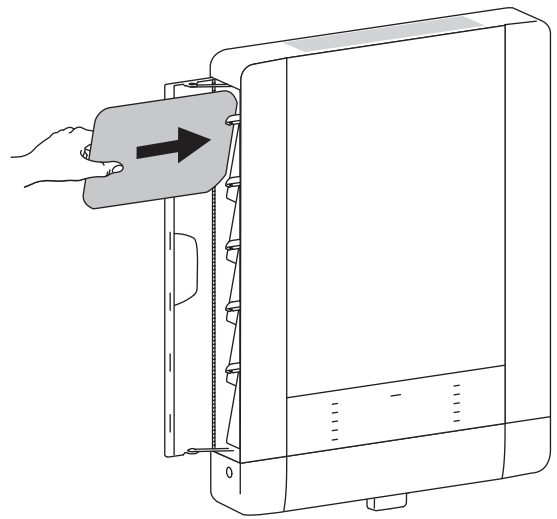

 NOTE: To keep door unlocked, pull key out while unlocked.



 NOTE: Tablet screen should face the wall when inserting.

8

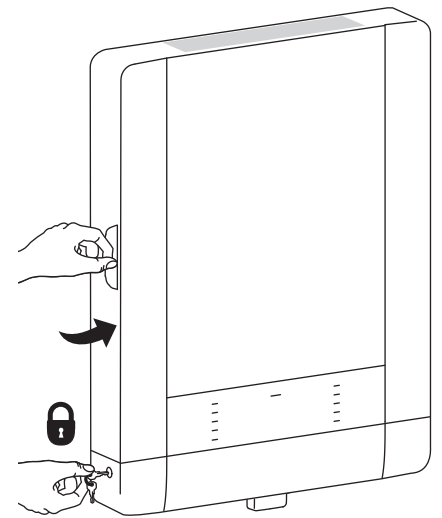
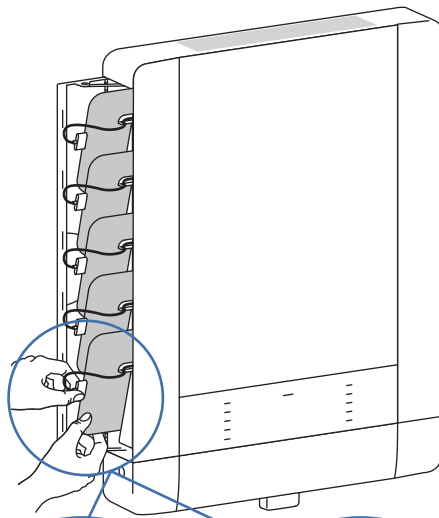
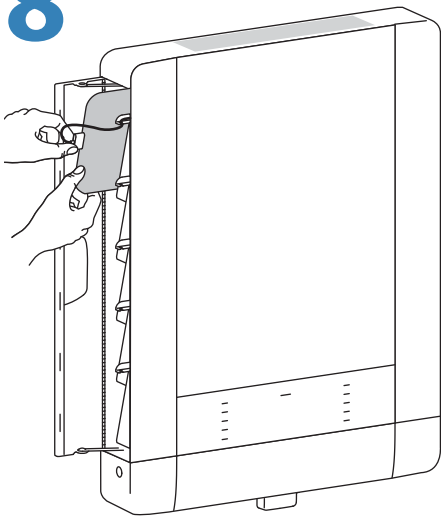

30 Pin Cable

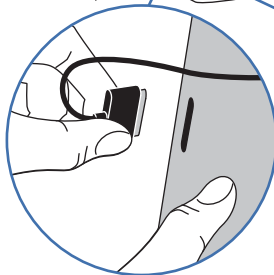

Lightning™ Cable

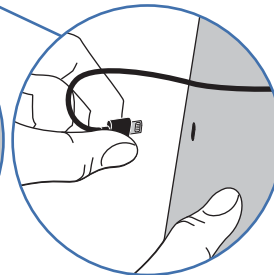

9

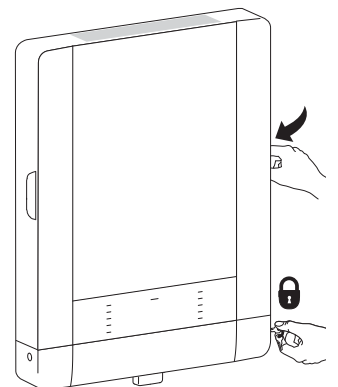
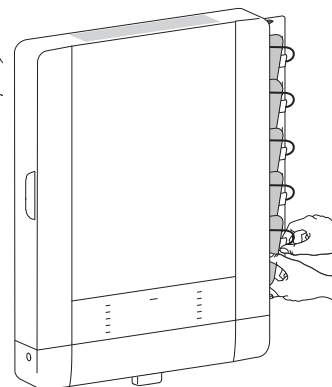
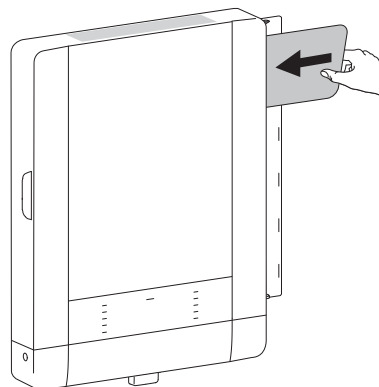
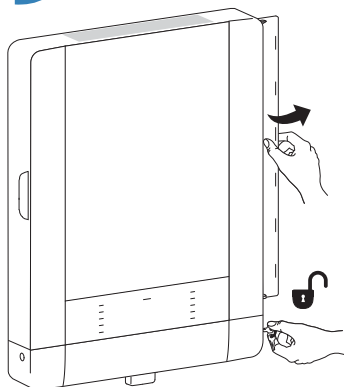

10 Tablet Charging

To begin charging the tablets, plug in the power cord.

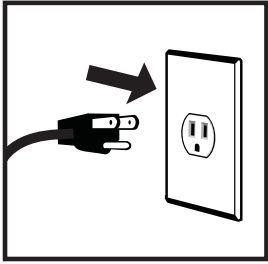



The power cord is used to turn the power on and off. Charging occurs whenever the power cord is connected UNLESS a Macintosh® or PC notebook USB cable is connected for syncing.



NOTE: The power cord acts as the connect/disconnect device switching power off and on. The socket outlet shall be installed near the equipment and shall be easily accessible.

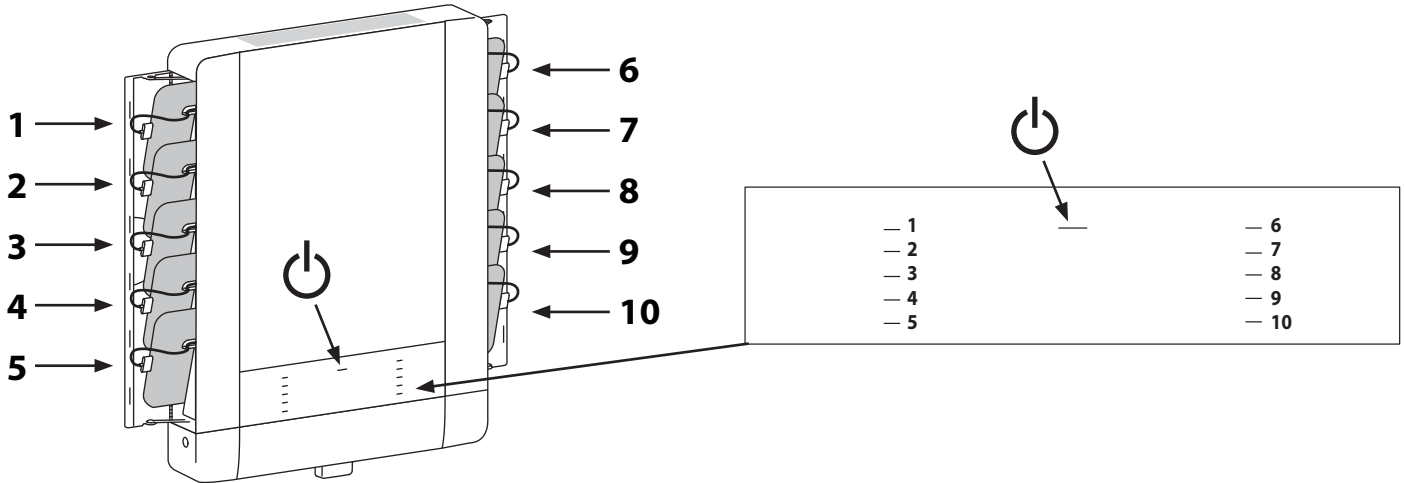

LED - Indicators



 **Power Indicator** – Communicates sync and charge status with the following signals:

Light	Description
Off	No power to the module.
On - solid	iPad devices are charging.
On - slow blink	Computer is plugged into USB port and iPad devices are ready to sync or are syncing.
On - fast blink	Fault Status. Please make sure all cables are seated correctly and product is operating within specified operating temperature. Can also indicate a failed 30 pin or lightning cable. Contact Ergotron Customer Support if problem continues.

1-10 Individual Status Indicators (ISI) – Sequentially numbered LEDs (1 - 10) corresponding to each tablet slot in the unit:

Light	Description
Green 	Fully charged.
Amber 	Charging in progress.
Off	No device connected.



NOTE: If module is syncing all ISIs will be green.

Tablet Syncing



NOTE: Complete the Tablet Charging instructions before syncing. iPad devices should be charged at least 50% before starting the syncing process.

Syncing can be done using iTunes® or the Apple Configurator program available for the Macintosh® computer. Please reference www.Apple.com for more information.

NOTE: The devices will not charge while syncing is in process. To return to charge mode, unplug the USB cable from the TM Wall Mount 10 USB port when syncing is complete.

The iPad devices will mount as USB devices when the A to B USB cable (not included) is connected to a host notebook via the USB port on the bottom of the TM Wall Mount 10.

If using iTunes, please see separate iTunes setup instructions available on the Ergotron website **Tablet Management Wall Mount 10** product page.

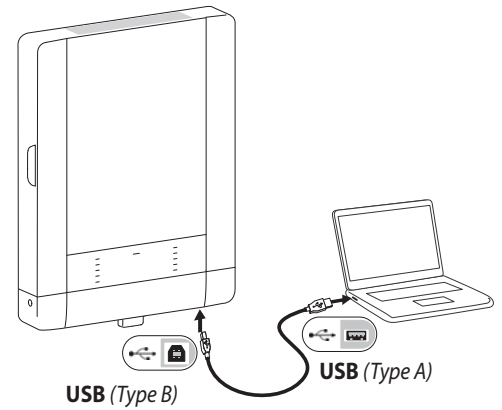

Cleaning and Maintenance

Equipment Electric Safety

There are specific risks associated with the use of equipment having power cables. You must be aware of, and avoid these risks when this product is located in close proximity to children.



WARNING: Failure to observe the following Electrical Safety notices can result in fire or death by electric shock.



Electrical cables can be hazardous. Misuse can result in fire or death by electrical shock.

- Double Pole / Neutral Fusing
- Inspect power cables thoroughly before each use.
- Do not use cables that are damaged.
- Insert the plug completely into the outlet.
- Grasp the plug to remove from the outlet.
- Do not unplug by pulling on the cable.
- Do not use excessive force to make connections.
- Do not plug the cable into an extension cable.
- Do not remove, bend or modify any metal prongs or pins of cable.
- Do not drive, drag or place objects over the cable.
- Do not walk on the cable.
- Avoid overheating. Uncoil the cable and do not cover it with any material.
- Do not run cable through doorways, holes in ceilings, walls or floors.



Keep this product away from water.

- Do not use it when wet.
- Do not place this product in close proximity to flammable liquids or gases.



This product is intended for use only with loading as indicated. Use with loads greater than indicated may result in instability causing possible injury.



The power cord acts as the connect/disconnect device switching power off and on. The socket outlet shall be installed near the equipment and shall be easily accessible.



CAUTION: Changes or Modifications not expressly approved by Ergotron could void the user's authority to operate the equipment.

Use Safety

There are specific risks associated with the use of this product (for charging or storage). You must be aware of, and avoid these risks when this product is located in close proximity to children.



WARNING: Failure to observe the following Use Safety notices may result in serious personal injury or equipment damage.

Only Adults should use this product.

- Do not allow anyone to climb or hang on this product.
- Do not block the fans and vent openings. To prevent overheating, leave at least 127 mm (4-inch) clearance around fans and vents.

This product is designed to be used indoors only.

- Do not use this product to store equipment other than what has been noted in this guide.
- Do not use this product to store liquids or cleaning supplies.
- Do not place heavy objects on this product.
 - The maximum weight capacity is 24 lbs (11 kg).







This device complies with Part 15 of the FCC Rules. Operation is subject to the following two conditions: 1) This device may not cause harmful interference. 2) This device must accept any interference received, including interference that may cause undesired operation.



CAN ICES-3(A) / NMB-3(A).

この装置は、クラスA情報技術装置です。この装置を家庭環境で使用すると電波妨害を引き起こすことがあります。この場合には使用者が適切な対策を講ずるよう要求されることがあります。VCCI-A

TABLET MANAGEMENT WALL MOUNT

Input: 100-240V~, 2.0A, 50/60 Hz

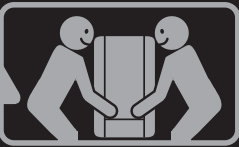
Product of China 827-039-01

Specifications

Dimensions

23.2"W x 31.8"H x 4.0"D (59 x 80.9 x 10.2 cm)

Weight (w/o equipment)

34.5 lbs (15.7 kg)

Rated weight capacity

24 lb (11 kg)

Maximum tablet size

Individual tablet dimensions (including cover):
up to 10.2"H x 7.9"W x 0.9"D (25.9 x 20.1 x 2.3 cm)

Individual tablet weight:
up to 2.4 lb (1.1 kg)

LED status indicators (ISI)

Lights indicate power status and syncing activity
10 LED lights

Cooling/ventilation

One 12-volt DC continuous operation fan in each module

Shipping dimensions

36.5" x 26.4" x 7.0" (92.6 x 67.0 x 17.7 cm)

Shipping weight

43 lb (19.5 kg)

Power system

Input: 100-240V~, 2.0A, 50/60 Hz

Environmental

Temperature range:
Operating 0° to 30°C (32° to 86°F)
Storage -40° to 60°C (-40° to 140°F)
Relative humidity (maximum):
Operating 10%–90% (non condensing)
Storage 5%–95% (non condensing)
Altitude (maximum): 2000 m (6,562 ft)

Compatibility:

Model DM10-1006-X Made for
iPad (3rd generation)
iPad 2
iPad

Model DM10-1007-X Made for
iPad Air™
iPad (4th generation)
iPad mini™ with Retina® display
iPad mini™



205 Westwood Ave, Long Branch, NJ 07740
Phone: 866-94 BOARDS (26273) / (732)-222-1511
Fax: (732)-222-7088 | E-mail: sales@touchboards.com

Service and Warranty

For Service on the Ergotron Tablet Management Wall Mount Charging Station
for iPad

Visit www.ergotron.com



NOTE: When contacting customer service, reference the serial number.

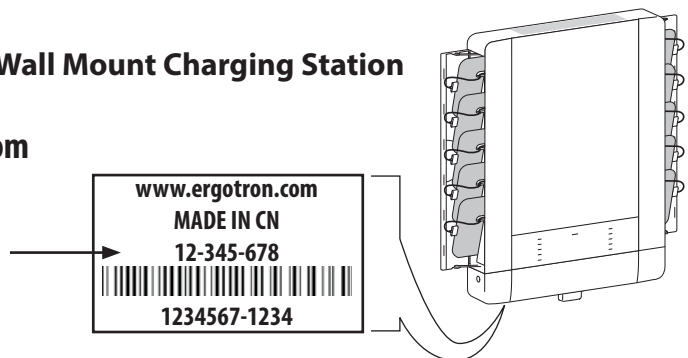

© 2013 Ergotron, Inc.
All rights reserved.

While Ergotron, Inc. makes every effort to provide accurate and complete information on the installation and use of its products, it will not be held liable for any editorial errors or omissions (including those made in the process of translation from English to another language), or for incidental, special or consequential damages of any nature resulting from furnishing this instruction and performance of equipment in connection with this instruction. Ergotron, Inc. reserves the right to make changes in the product design and/or product documentation without notification to its users. For the most current product information, or to know if this document is available in languages other than those herein, please contact Ergotron. No part of this publication may be reproduced, stored in a retrieval system, or transmitted in any form or by any means, electronic, mechanical, photocopying, recording or otherwise without the prior written consent of Ergotron, Inc., 1181 Trapp Road, Eagan, Minnesota, 55121, USA Patents Pending and Patented U.S. & Foreign. Ergotron is a registered trademark of Ergotron, Inc.