

CAUTION: DO NOT EXCEED
MAXIMUM LISTED WEIGHT
CAPACITY. SERIOUS INJURY
OR PROPERTY DAMAGE MAY
OCCUR!

For the latest User Installation Guide please visit: www.ergotron.com



User's Guide - English
Guía del usuario - Español
Manuel de l'utilisateur - Français
Gebruikersgids - Deutsch
Benutzerhandbuch - Nederlands
Guida per l'utente - Italiano
Användarhandbok - svenska
ユーザーガイド : 日本語
用户指南 : 汉语



Includes
Constant Force™
Technology



www.ergotron.com

USA 1-800-888-8458
Europe +31 (0)33-45 45 600
China 400-120-3051

Safety



WARNING

IMPACT HAZARD

Moving Parts Can Crush & Cut

Do not tip the cart over on side or upside down. Cart must remain upright at all times. Tipping cart on side or upside down may cause unintended motion of the riser. Failure to heed this warning may result in serious personal injury or property damage!

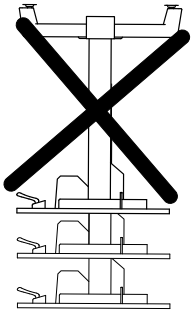
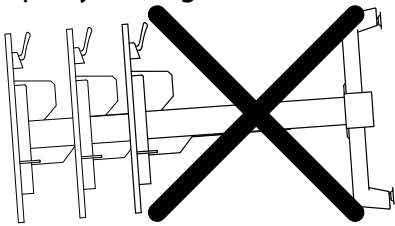

For more information on safe set-up and use of this product, refer to use manual at www.ergotron.com or contact Ergotron Customer Care at 1-800-888-8458.

827-515-00

ENGLISH

Components

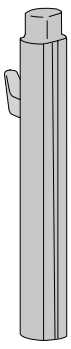
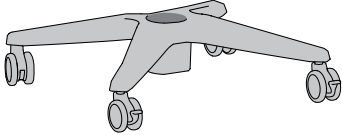
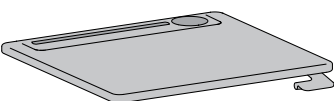

	A	B	C
1x		1x	1x
1			

Tools Needed



1 Remove base orientation indicator from base.

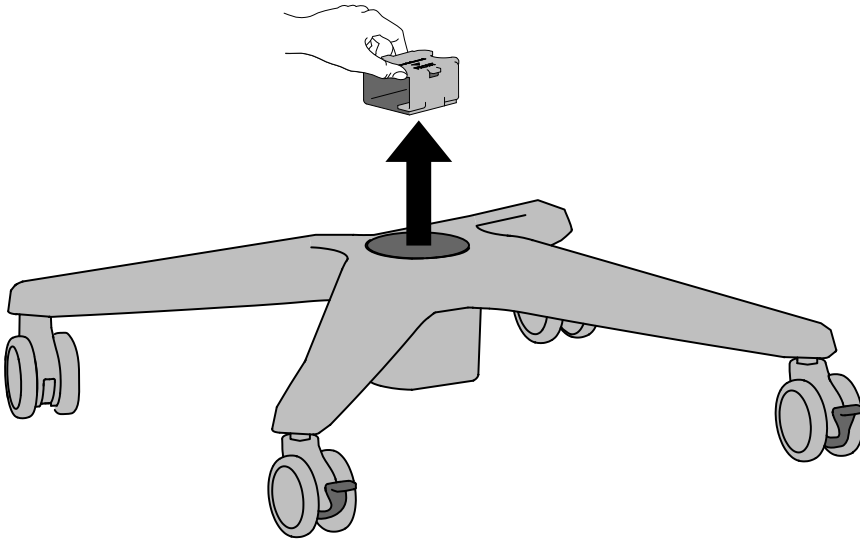

2 Partially insert riser into base.

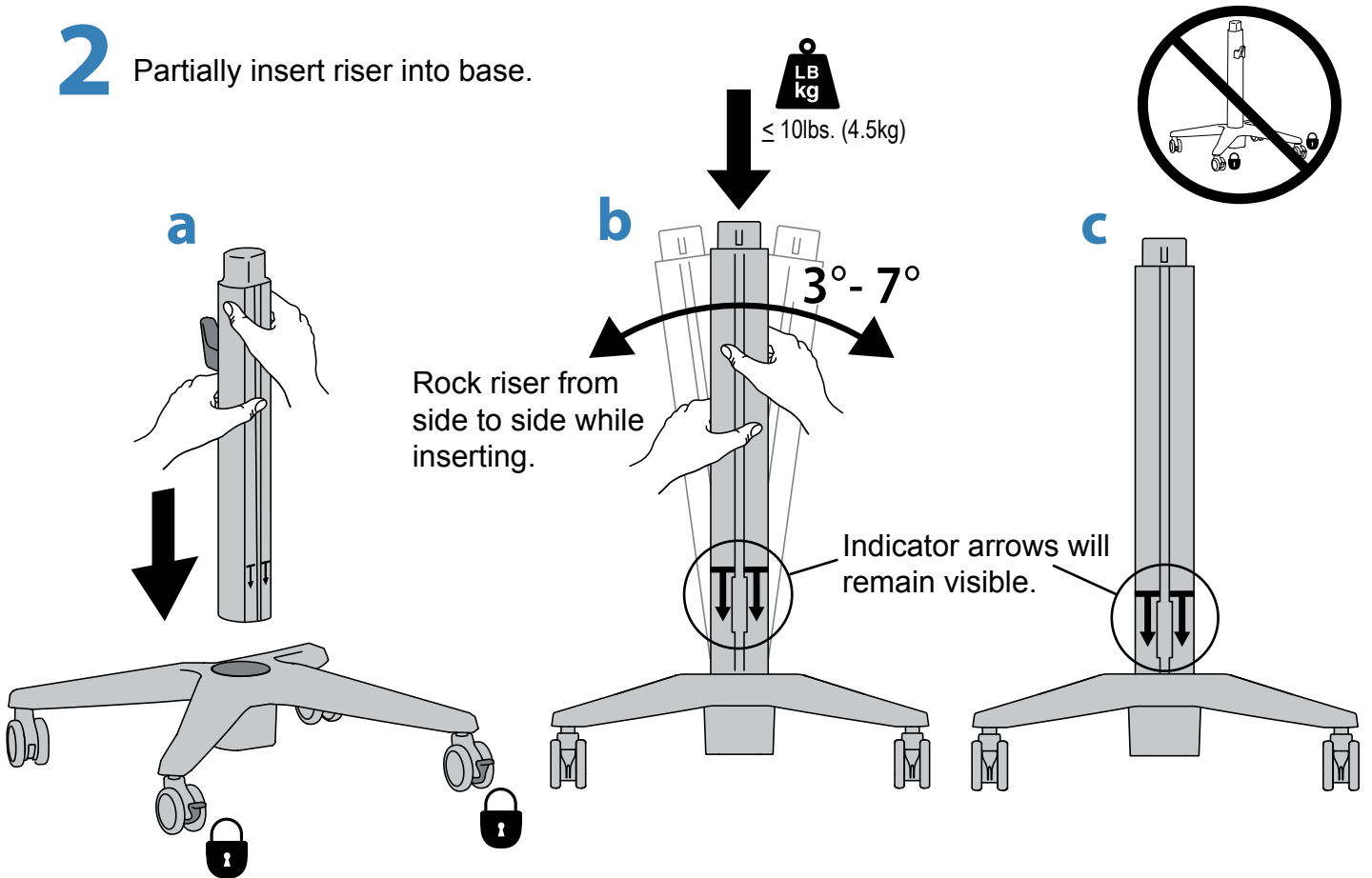

3 Remove cap.

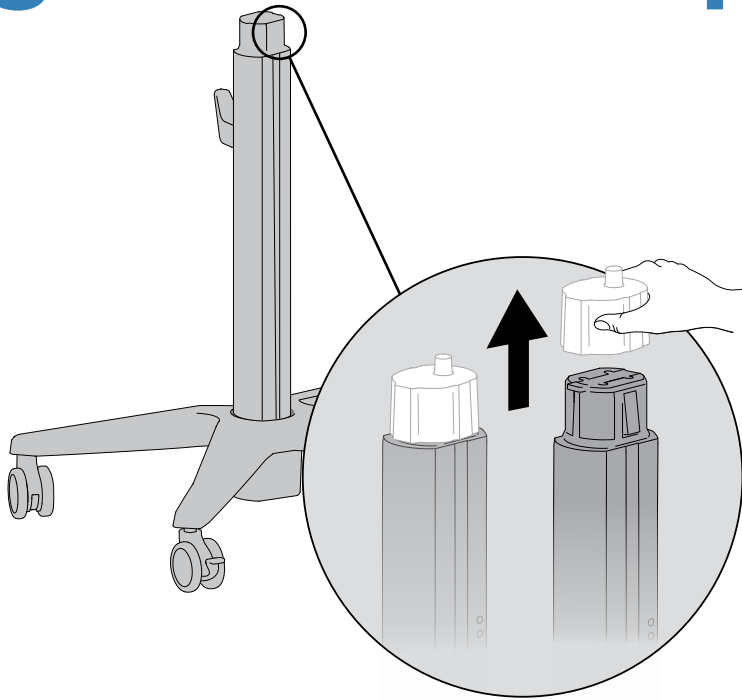

4 Attach work surface and press down.

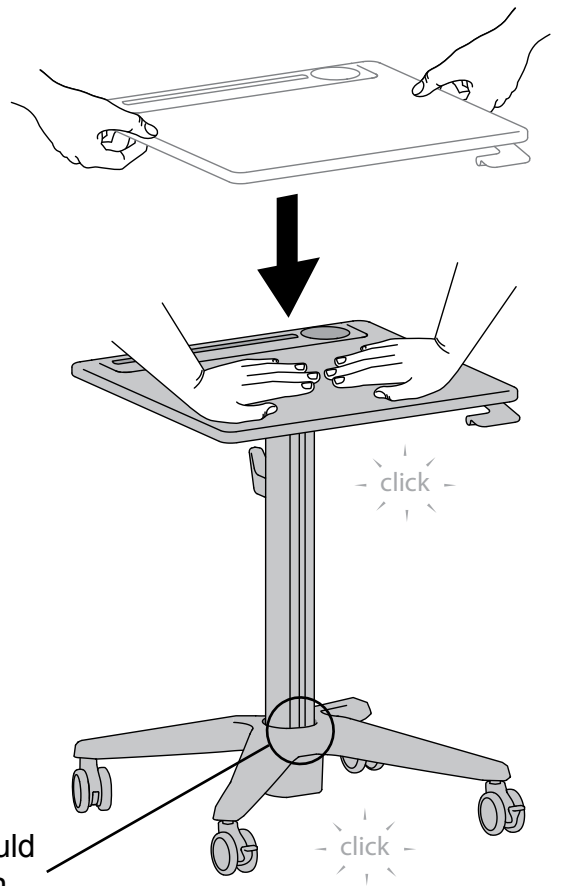

Indicator arrows should be completely hidden.

5 Lift up on the work surface to make sure it is securely attached to the base.

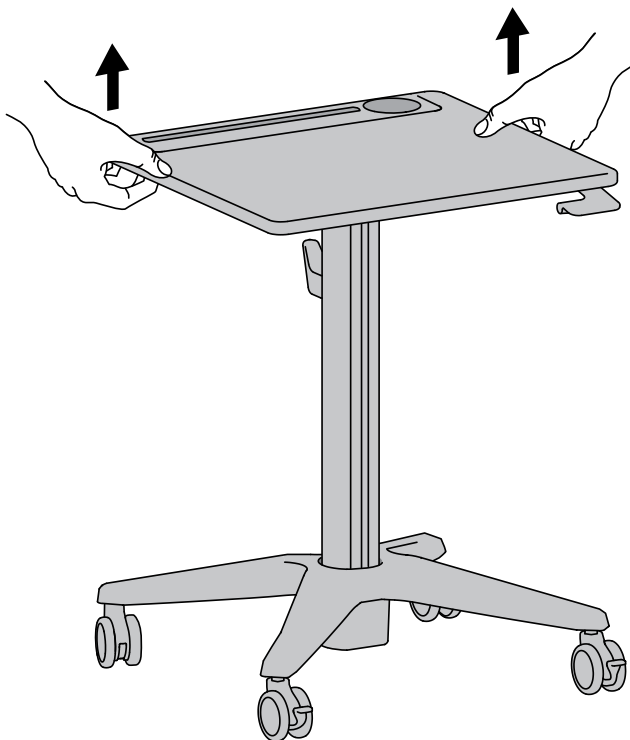

6

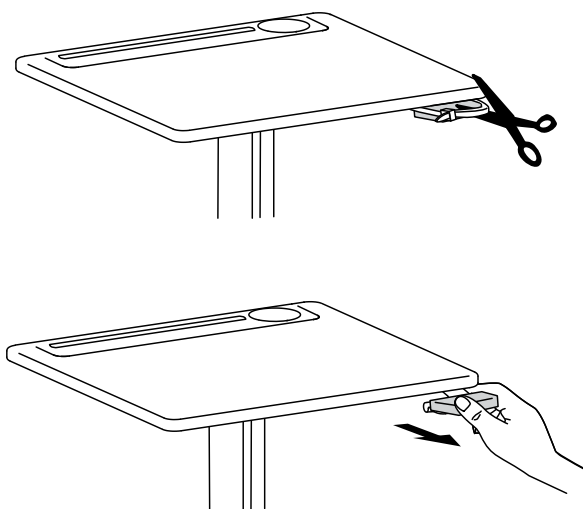

7

Lift brake release lever to raise and lower riser.

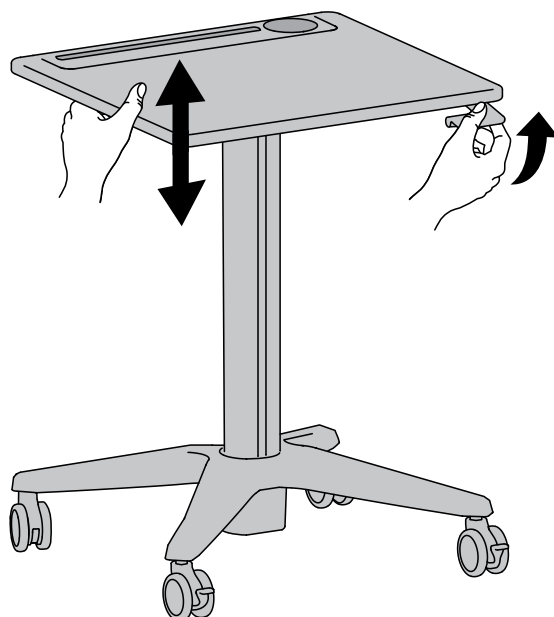

8

Loosen, but do not remove 2 screws to lift and lower hook to desired height.

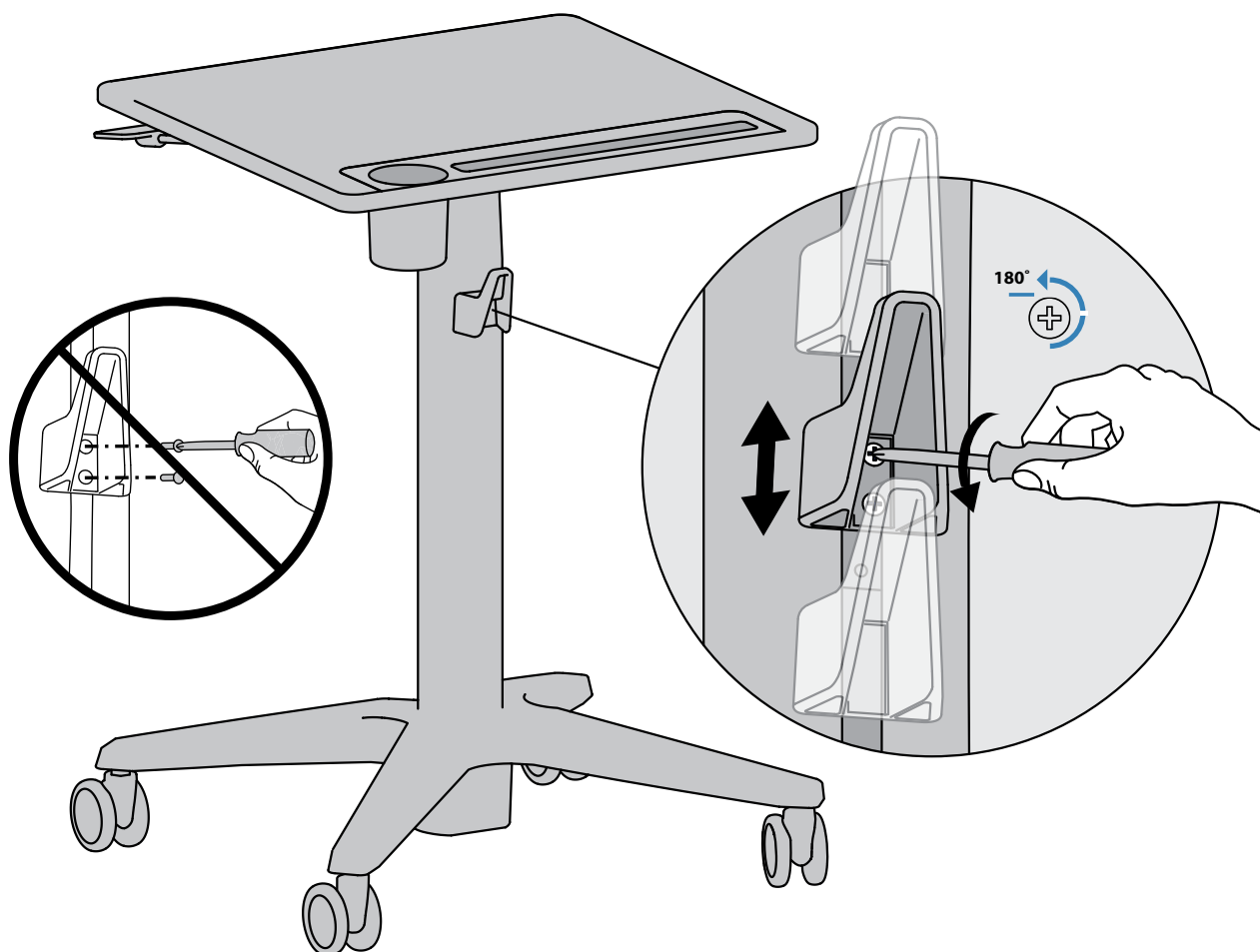

How to Disassemble

To remove worksurface, push tab with a tool while removing. (Hex wrench suggested, max diameter 4mm)

NOTE: Requires two people.

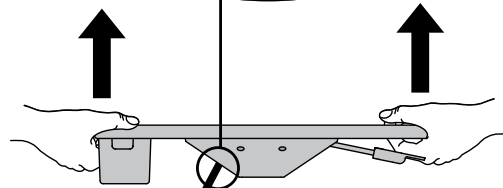
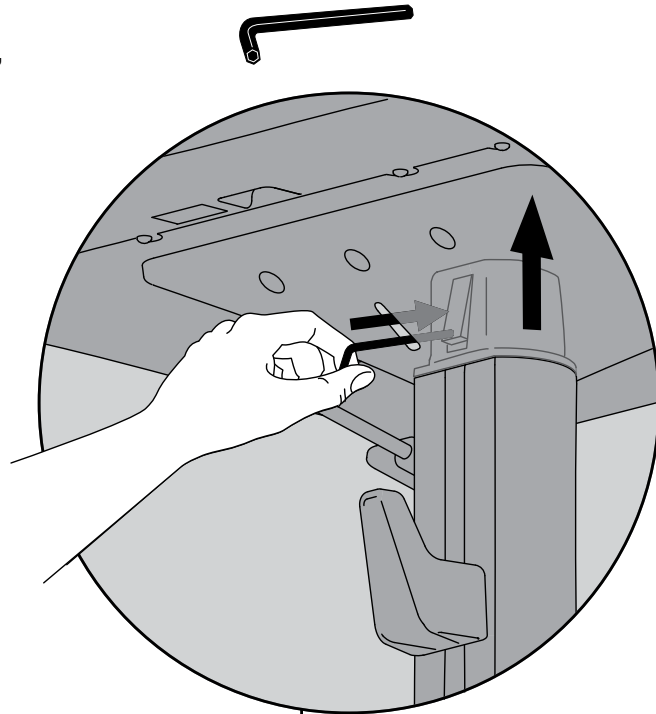
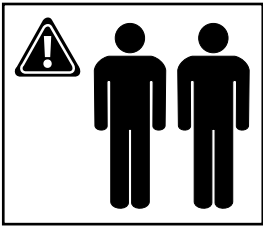

Attach cap.

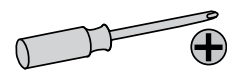
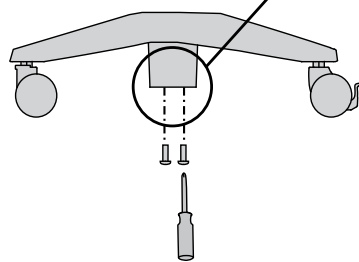
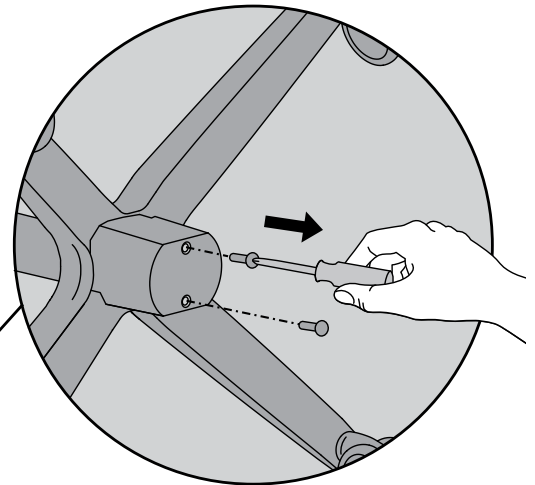
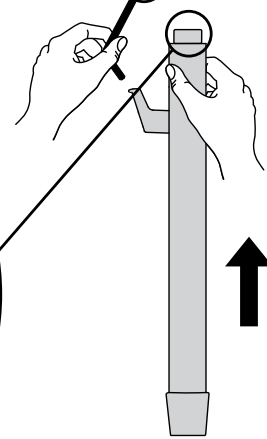
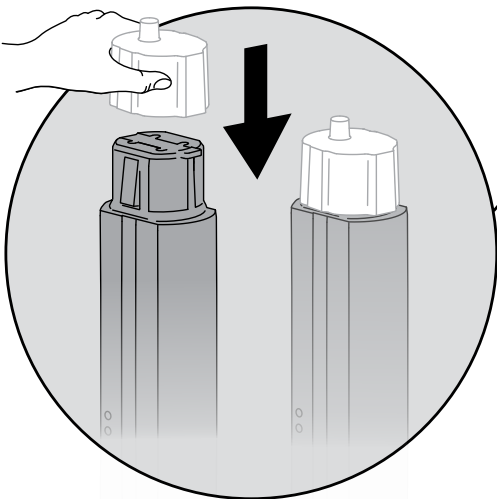

Set Your Workstation to Work For YOU!

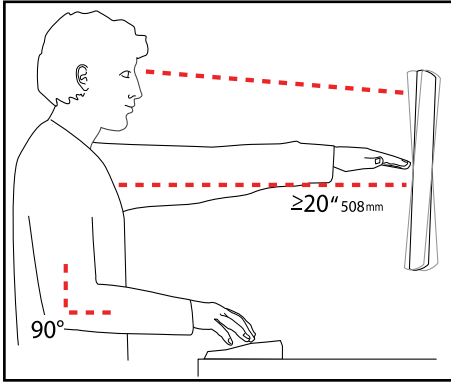

Learn more about ergonomic computer use at:
www.computingcomfort.org

- Height** Position top of screen slightly below eye level.
Position keyboard at about elbow height with wrists flat.
- Distance** Position screen an arm's length from face—at least 20" (508mm).
Position keyboard close enough to create a 90° angle in elbow.
- Angle** Tilt screen to eliminate glare.
Tilt the keyboard back 10° so that your wrists remain flat.

To Reduce Fatigue
Breathe - Breathe deeply through your nose.
Blink - Blink often to avoid dry eyes.
Break • 2 to 3 minutes every 20 minutes
• 15 to 20 minutes every 2 hours.

For service and warranty visit www.ergotron.com/warranty

For local customer care phone numbers visit: <http://contact.ergotron.com>



NOTE: When contacting customer service, reference the serial number.

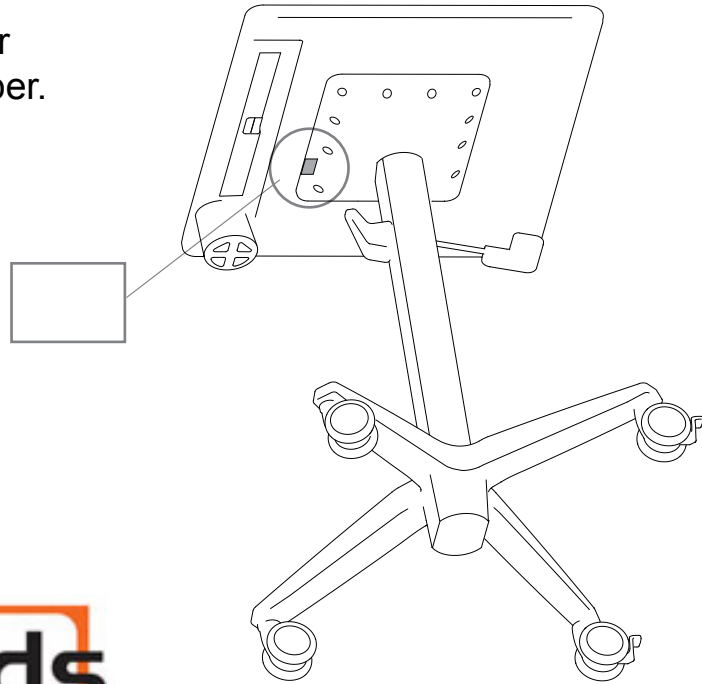

Touchboards

205 Westwood Ave, Long Branch, NJ 07740
Phone: 866-94 BOARDS (26273) / (732)-222-1511
Fax: (732)-222-7088 | E-mail: sales@touchboards.com

Americas Sales and Corporate Headquarters

1181 Trapp Rd.
St. Paul, MN USA
(800) 888-8458
+1-651-681-7600
www.ergotron.com
sales@ergotron.com

APAC Sales

Tokyo, Japan
www.ergotron.com
apaccustomerservice@ergotron.com

EMEA Sales

Amersfoort, The Netherlands
+31 33 45 45 600
www.ergotron.com
info.eu@ergotron.com

Worldwide OEM Sales

www.ergotron.com
info.oem@ergotron.com

ERGOTRON®

While Ergotron, Inc. makes every effort to provide accurate and complete information on the installation and use of its products, it will not be held liable for any editorial errors or omissions (including those made in the process of translation from English to another language), or for incidental, special or consequential damages of any nature resulting from furnishing this instruction and performance of equipment in connection with this instruction. Ergotron, Inc. reserves the right to make changes in the product design and/or product documentation without notification to its users. For the most current product information, or to know if this document is available in languages other than those herein, please contact Ergotron. No part of this publication may be reproduced, stored in a retrieval system, or transmitted in any form or by any means, electronic, mechanical, photocopying, recording or otherwise without the prior written consent of Ergotron, Inc., 1181 Trapp Road, Eagan, Minnesota, 55121, USA. Patents Pending and Patented U.S. & Foreign. Ergotron is a registered trademark of Ergotron, Inc.