

StyleView® SV44 Cart

with LCD Arm and LiFe Power System



205 Westwood Ave, Long Branch, NJ 07740
 Phone: 866-94 BOARDS (26273) / (732)-222-1511
 Fax: (732)-222-7088 | E-mail: sales@touchboards.com

StyleView powered carts provide electrical AC power for mobile point of care computing equipment in a healthcare environment. The carts are not intended to power medical products or devices. Outlets are provided to power information technology equipment only such as computer equipment and computer peripherals.

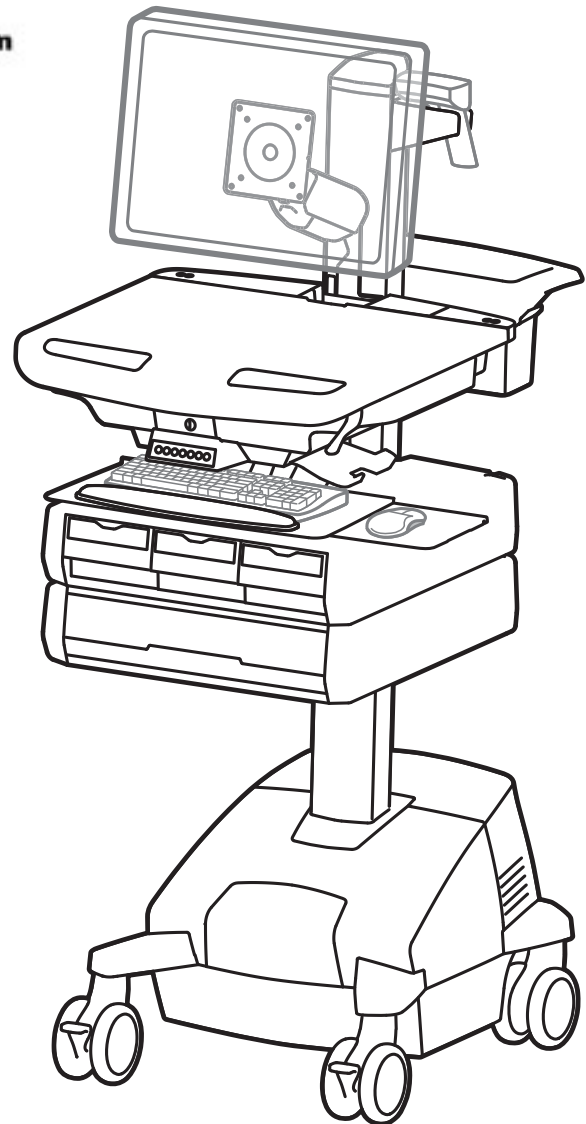

ENGLISH

Features & Specifications.....	3 - 6
Set-up	7 - 16
Adjustment	14
Battery Charge/Discharge	15
Auto-Lock Drawer.....	16 -17
Change Fuse (5 Amp)	18
Change Power System Batteries.....	19 - 20
Cart Storage (long term/short term).....	20
Ergonomics	21
Maintenance & Safety	21 - 24

For Warranty visit: www.ergotron.com/warranty

For Service visit: www.ergotron.com

For local customer care phone numbers visit: <http://contact.ergotron.com>

For the latest User Installation Guide and StyleLink Software Download please visit: www.ergotron.com



User's Guide - English
 Guía del usuario - Español
 Manuel de l'utilisateur - Français
 Gebrauchersgids - Deutsch
 Benutzerhandbuch - Nederlands
 Guida per l'utente - Italiano
 Användarhandbok - svenska
 ユーザーガイド : 日本語
 用户指南 : 汉语

 www.ergotron.com
 USA 1-800-888-8458
 Europe +31 (0)33-45 45 600
 China 400-120-3051

WARNING
AVERTISSEMENT

IMPACT HAZARD!
MOVING PARTS CAN CRUSH AND CUT.
Failure to heed this warning may result in serious personal injury or property damage!

Minimize Lift Tension BEFORE:
Removing Mounted Equipment, Shipping Cart, Storing Cart.

DANGER D'IMPACT !
LES PARTIES EN MOUVEMENT PEUVENT ÉCRASER ET COUPER.
Il existe un risque de blessure corporelle ou d'endommagement matériel en cas de non respect de cet avertissement.

Minimisez la tension d'élévation AVANT :
de retirer l'équipement fixé, d'expédier le chariot, de stocker le chariot

www.ergotron.com

826-501

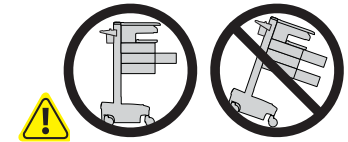
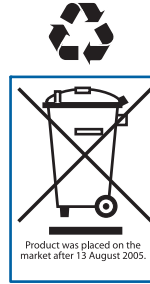
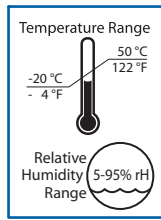
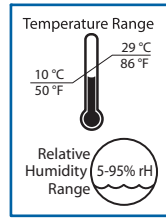

CAUTION: Close worksurface before opening drawers. Open only one drawer at a time. Do Not push cart when drawers or worksurface are open. Failure to follow these instructions may cause the cart to be unstable.

This Class A digital apparatus complies with Canadian ICES-003.

Cet appareil numérique de la classe A est conforme à la norme NMB-003 du Canada.

FCC Compliance Statement

The cart has been tested and found to comply with the limits for a Class A digital device, pursuant to part 15 of the FCC Rules. These limits are designed to provide reasonable protection against harmful interference when the equipment is operated in a commercial environment. This equipment generates, uses, and can radiate radio frequency energy and, if not installed and used in accordance with the instruction manual, may cause harmful interference to radio communications. Operation of this equipment in a residential area is likely to cause harmful interference in which case the user will be required to correct the interference at his own expense.

Changes or modifications not expressly approved by Ergotron, Inc. could void the user's authority to operate the equipment.

Please contact Ergotron for complete EMC compatibility information.

IMPORTANT! This product will need tension adjustments once installation is complete. Make sure all equipment is properly installed on the product before attempting range of motion or tension adjustments. Any time equipment is added or changed on this product resulting in a different mounted weight, you should repeat the adjustment steps to ensure safe and optimum operation. This product should move smoothly and easily through the full range of motion and stay where you set it. If movement is difficult or the product does not stay where you set it, follow the adjustment instructions to loosen or tighten the tension to create a smooth, easy motion. Depending on your product and the adjustment, it may take many turns to notice a difference.

Components

	A	B
1	1x 12x	4x 3x
2	1x 1x	2x
3	1x M4 x 5mm	
4	4x M4 x 10mm 8x M4 x 10mm	2x 1x
5	1x 1x	1x M4 x 8mm
6	1x 4x 1x M4 x 8mm	1x
7	1x 5mm	1x 3mm
8	1x	1x 1x
9	2x M4 x 12mm	1x

Tools Needed

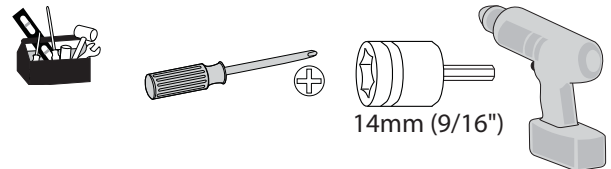

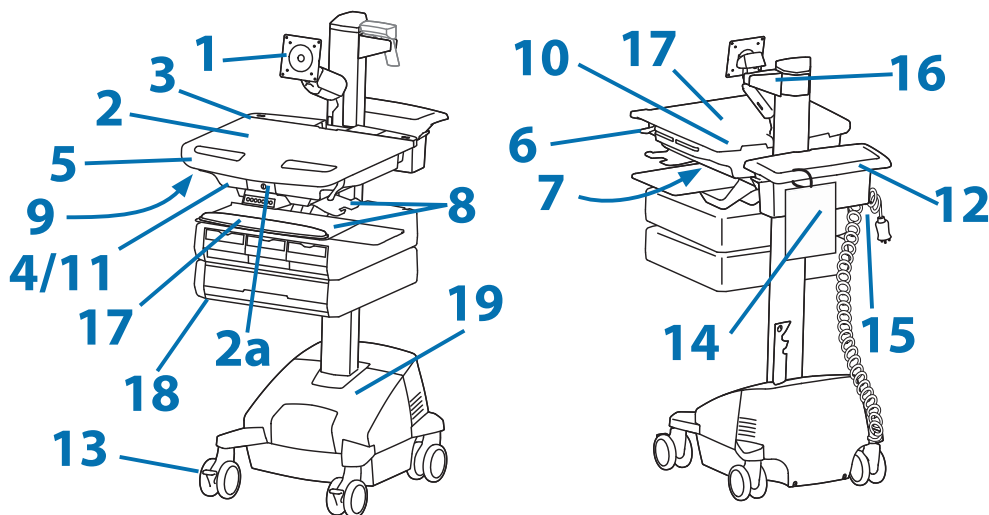

1. Height Adjustable LCD Mount attaches LCDs or tablet PC's with 75x75 or 100x100mm mounting interface
2. Worksurface 2a. Worksurface Lock and Release
3. User Interface for Power System
4. Secure Storage for Laptop, Thin Client or CPU
5. Front Handle
6. Height Adjustment Brake Handle
7. USB Hub connects keyboard and mouse USB cables
8. Keyboard tray slides out, tilts and allows for right or left mousing with attached mouse holder
9. Keyboard Light under Front Handle
10. Keyboard Light Switch
11. Cable Management and Storage for excess cables and power supplies
12. Storage Basket and Rear Handle
13. Front Locking Casters
14. Quick Reference Card
15. Power Cord Hooks
16. Scanner Holder
17. Antimicrobial worksurface and antimicrobial coating on wrist rest
18. Auto-Lock Drawer (see page 3 for drawer configurations)
19. **Power System**

The StyleView AC Power System allows your power supply to travel with the cart. The Power System is integrated in the base of the cart and comes standard with battery, power module, User Interface (UI), outlet box and power cord.

- User Interface (UI): Allows power system output to be turned on or turned off, monitors battery charge remaining, and provides low battery charge audible alarm.
- Battery: One 40-Ah Lithium battery.
- The minimum operational temperature is 10°C (50°F) and the maximum operational temperature is 29°C (86°F). The recommended humidity range for operation is 5-95% rH.
- The recommended cart storage temperature is 25°C (77°F). At this temperature, the battery's age-related capacity loss is minimized. The minimum storage temperature is -20°C (-4°F) and the maximum storage temperature is 50°C (122°F). The recommended humidity range for storage is 5-95% rH.

Features & Specifications

Part Number	Auto-Lock Drawer	Power System
SV44-1212-1	1 Drawer*/16 compartments	Input: 120VAC/60 Hz, 5.0A; Output: 120VAC/60 Hz, 150VA, 150W. • The cart and power system are certified to UL 60601 and CAN/CSA-C22.2 601.1-M90
SV44-12B2-1	1 Drawer*/9 compartments	
SV44-1222-1	2 Drawers*/32 compartments	
SV44-12A2-1	2 Drawers*/8 compartments	
SV44-12C2-1	2 Drawers*/8 compartments	
SV44-1232-1	3 Drawers*/48 compartments	
SV44-1242-1	4 Drawers*/28 compartments	
SV44-1262-1	6 Drawers*/24 compartments	
SV44-1292-1	9 Drawers*/36 compartments	
SV44-1212-2 SV44-1212-3 SV44-1212-B SV44-1212-C	1 Drawer*/16 compartments	Input: 230V~/ 50/60 Hz, 2.5A; Output: 230V~/ 50/60 Hz, 150VA, 150W. • The cart and power system are compliant with EN 60601-1.
SV44-12B2-2 SV44-12B2-3 SV44-12B2-B SV44-12B2-C	1 Drawer*/9 compartments	
SV44-1222-2 SV44-1222-3 SV44-1222-B SV44-1222-C	2 Drawers*/32 compartments	
SV44-12A2-2 SV44-12A2-3 SV44-12A2-B SV44-12A2-C	2 Drawers*/8 compartments	
SV44-12C2-2 SV44-12C2-3 SV44-12C2-B SV44-12C2-C	2 Drawers*/8 compartments	
SV44-1232-2 SV44-1232-3 SV44-1232-B SV44-1232-C	3 Drawers*/48 compartments	
SV44-1242-2 SV44-1242-3 SV44-1242-B SV44-1242-C	4 Drawers*/28 compartments	
SV44-1262-2 SV44-1262-3 SV44-1262-B SV44-1262-C	6 Drawers*/24 compartments	
SV44-1292-2 SV44-1292-3 SV44-1292-B SV44-1292-C	9 Drawers*/36 compartments	

ENGLISH

*Auto-Lock Drawer

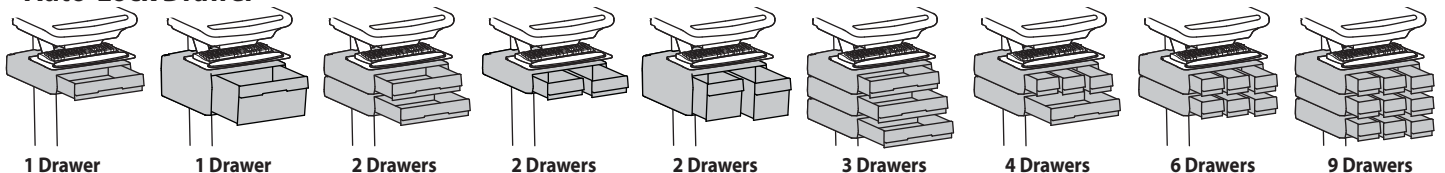

Features & Specifications

Weight Capacity



CAUTION: DO NOT EXCEED MAXIMUM LISTED WEIGHT CAPACITY. SERIOUS INJURY OR PROPERTY DAMAGE MAY OCCUR!

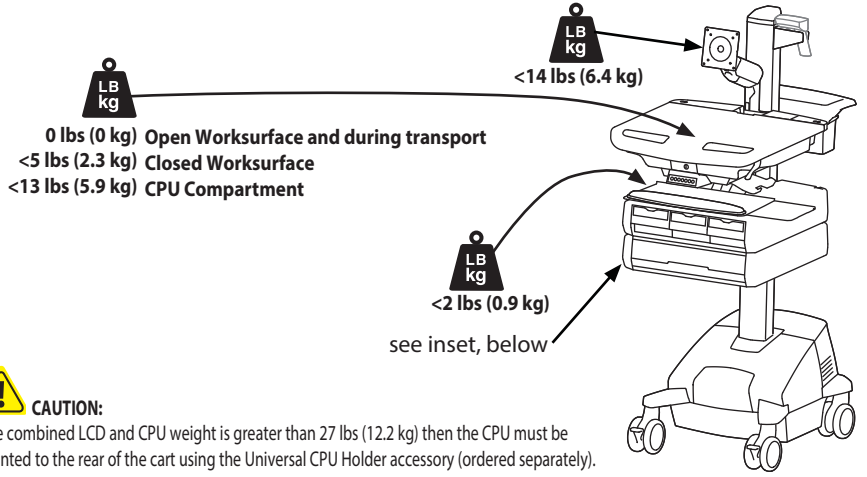

CAUTION: If the combined LCD and CPU weight is greater than 27 lbs (12.2 kg) then the CPU must be mounted to the rear of the cart using the Universal CPU Holder accessory (ordered separately).

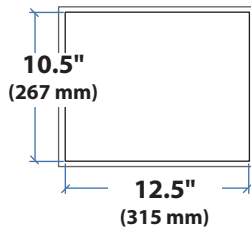
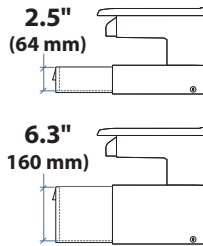
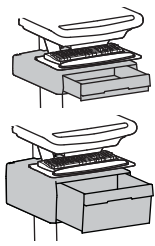

Total weight capacity per drawer.
≤ 2 lbs (1 kg)

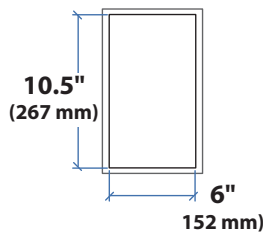
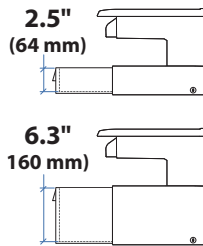
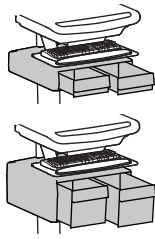
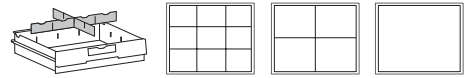

Total weight capacity per drawer.
≤ 1 lbs (0.5 kg)

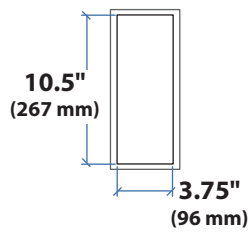
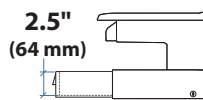
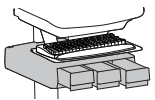
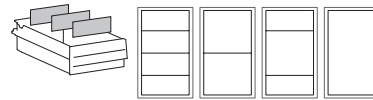

Total weight capacity per drawer.
≤ 0.25 lbs (0.1 kg)

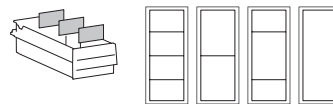

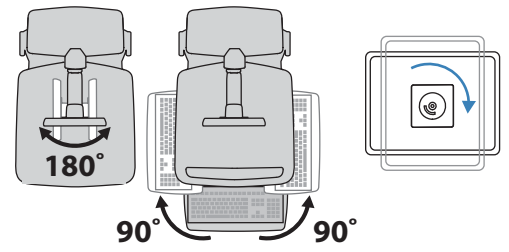
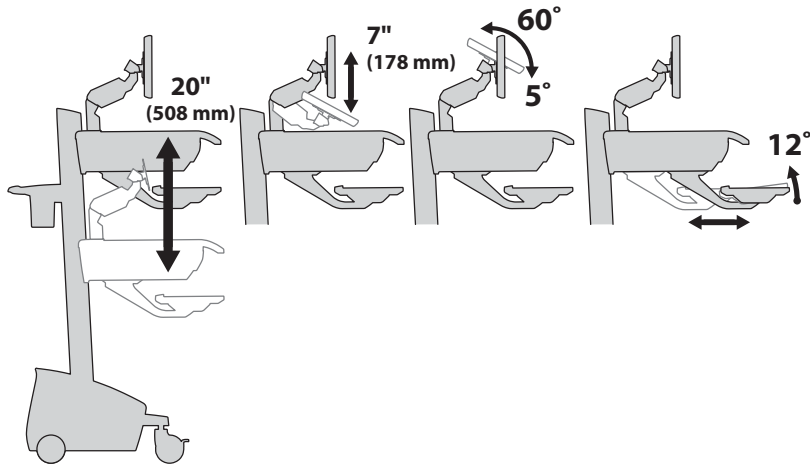

ENGLISH

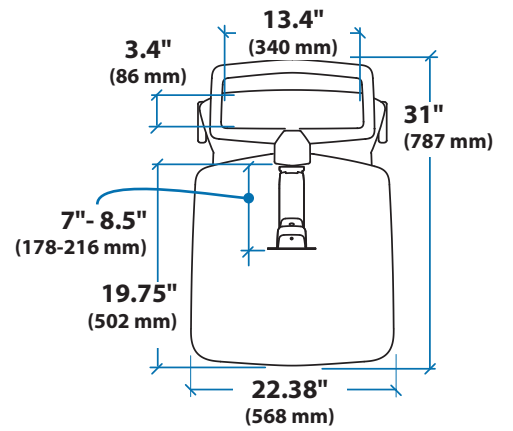
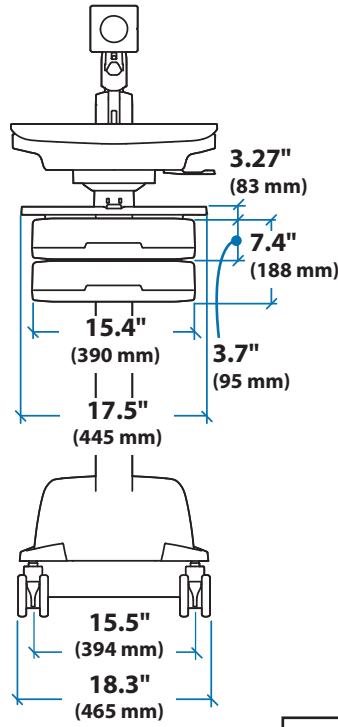
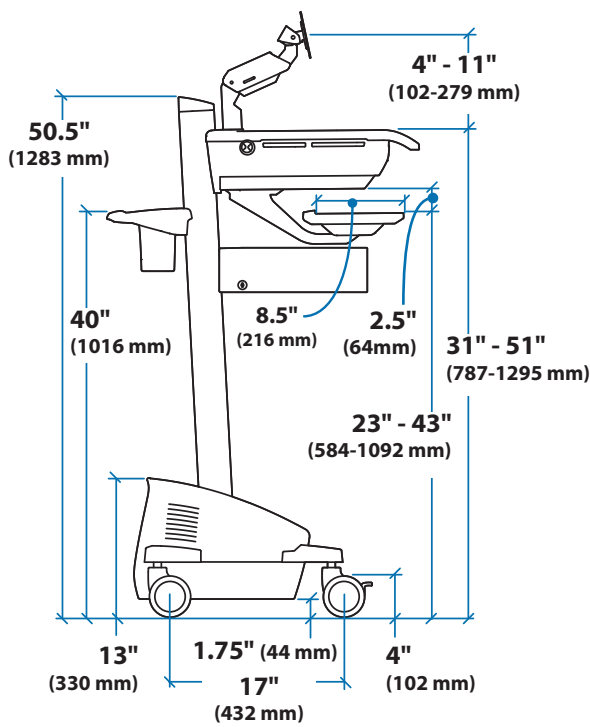

CPU Compartment

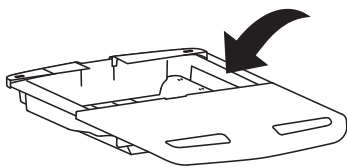

When figuring dimensions, include mounted accessories, protruding cables and port replicators or docking stations.

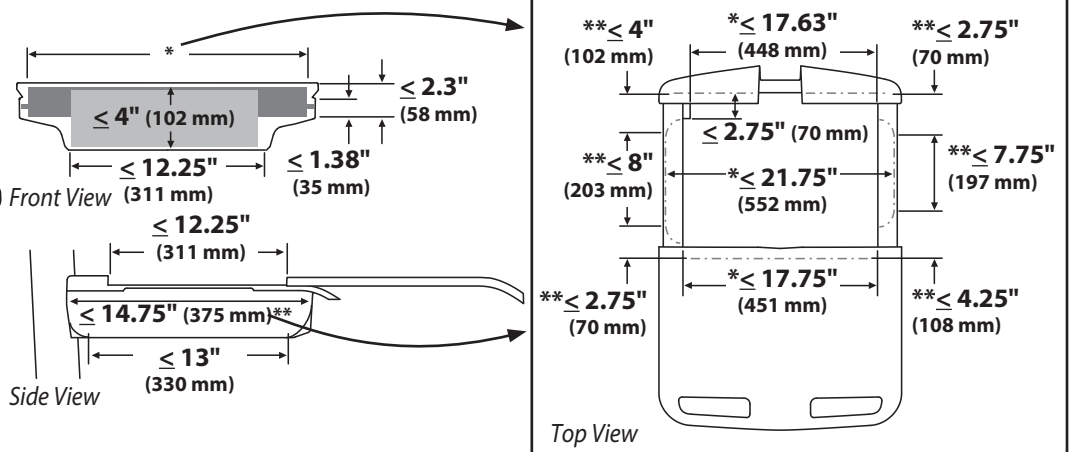

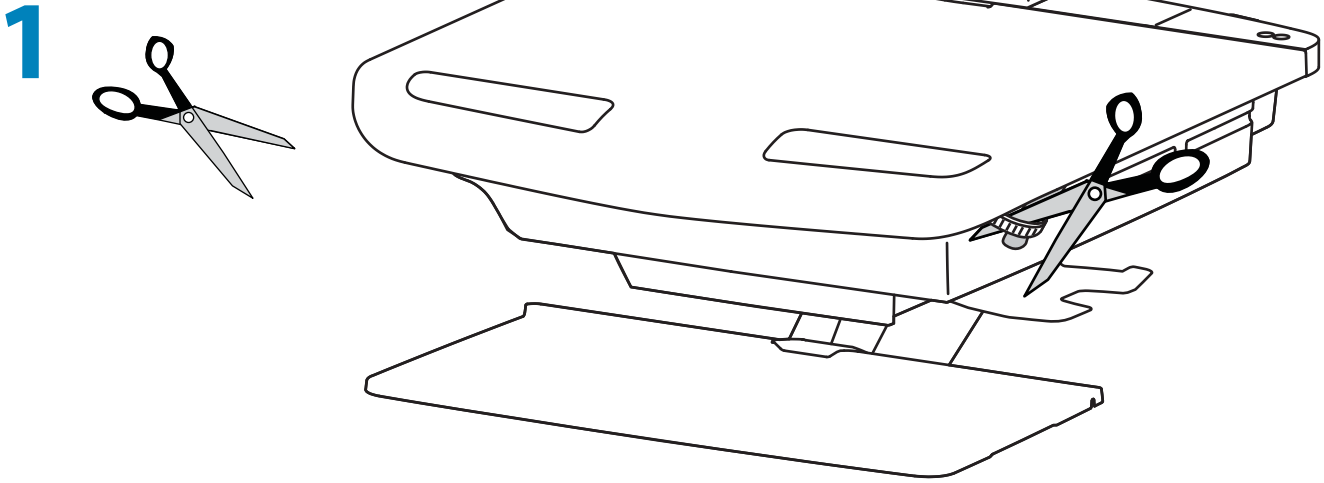

Release Brake to move riser.

CAUTION! Completely release brake engagement before raising or lowering the cart. Raising or lowering the cart with the brake partially engaged may cause product damage.

2 a

1x Sterile Alcohol Prep

60

00:50

1x

b

1x Sterile Alcohol Prep

60

00:50

1x

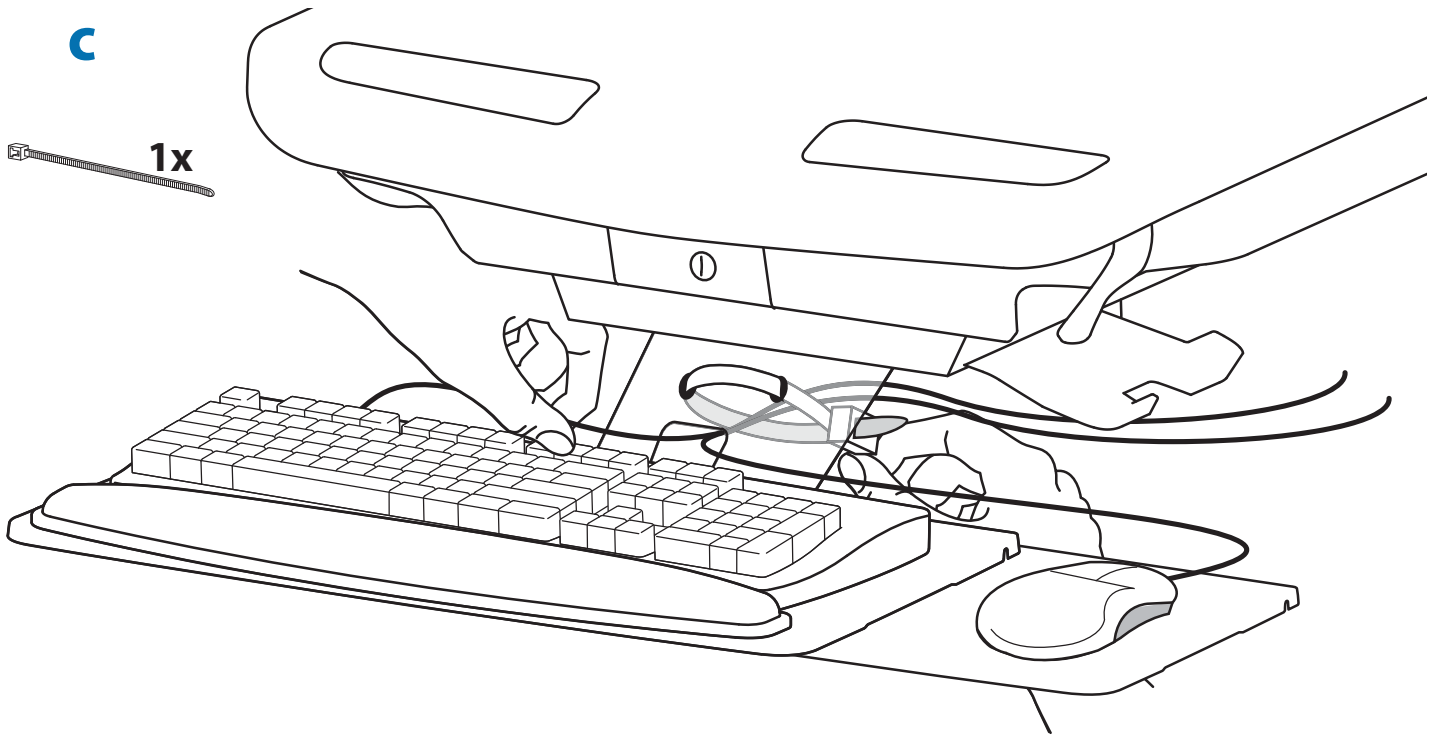

ENGLISH

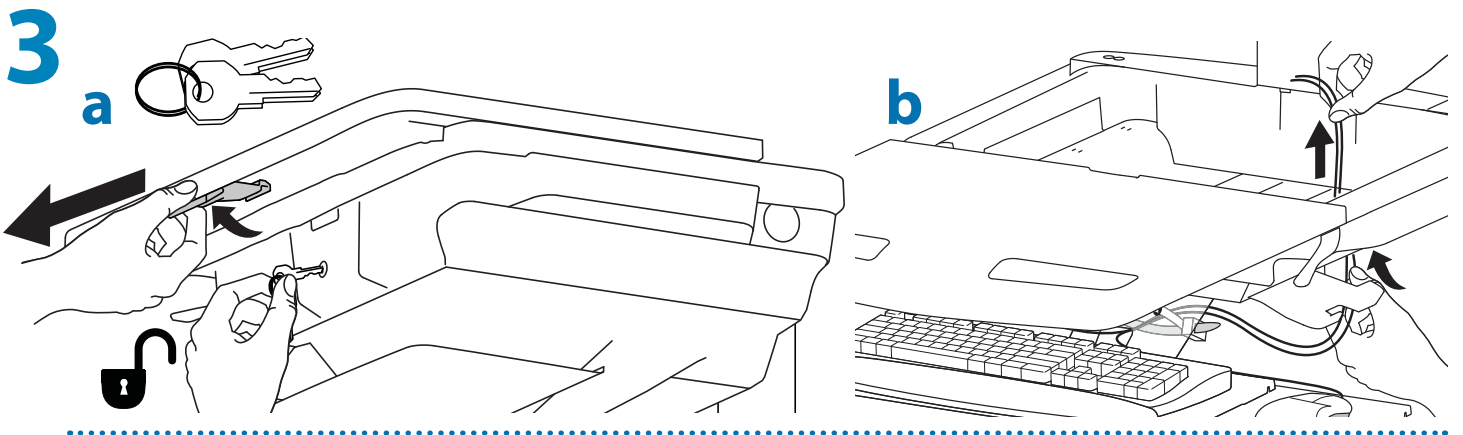

C Connect Keyboard and Mouse to USB Hub

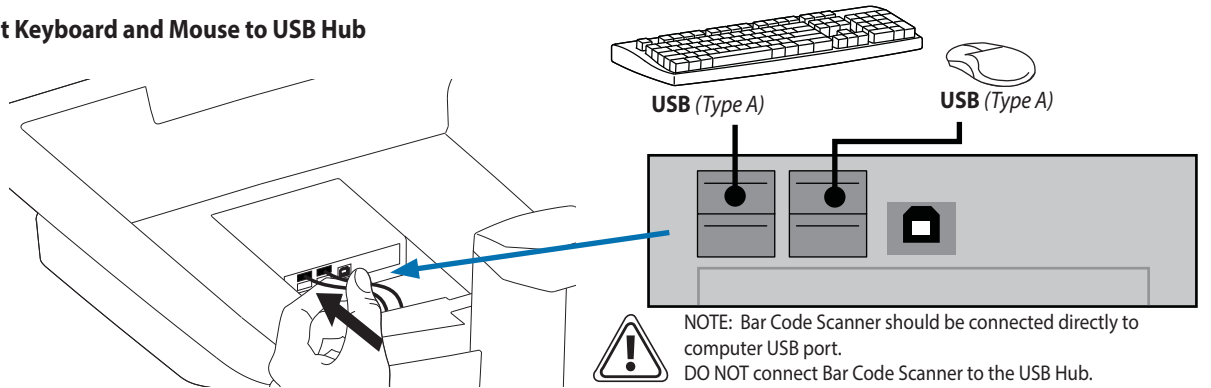

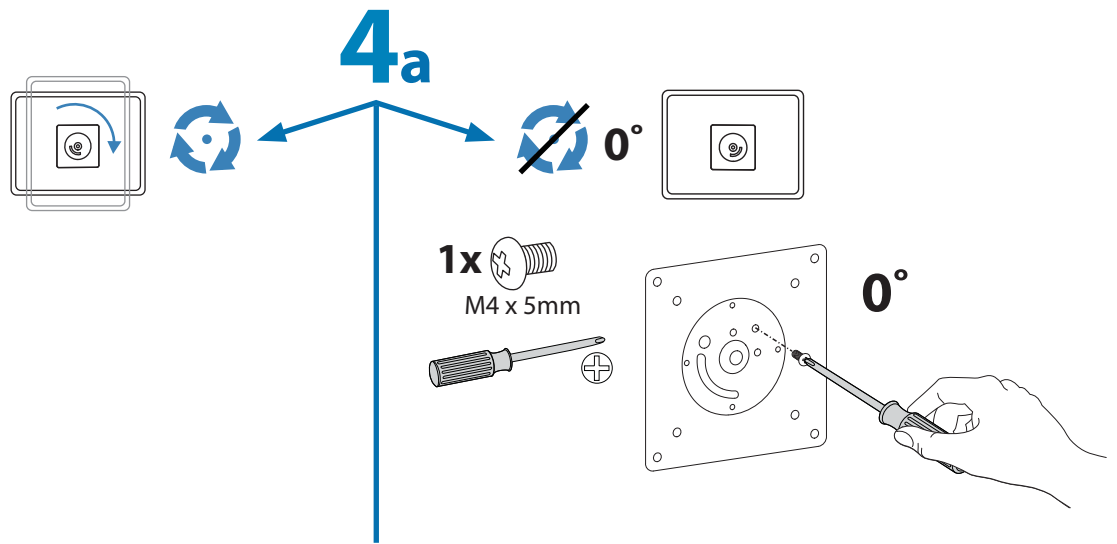

b 75x75mm / 100x100mm

WARNING
Impact Hazard!
 Moving Parts can Crush and Cut.
 Raise monitor to top of vertical adjustment BEFORE removing.
 Failure to heed this warning may result in serious personal injury or property damage!
 826-504

AVERTISSEMENT
Danger d'impact !
 Les parties en mouvement peuvent écraser et couper. Élevez l'écran au plus haut de l'ajustement AVANT de le retirer.
 Il existe un risque de blessure corporelle ou d'endommagement matériel en cas de non respect de cet avertissement.
 827-404

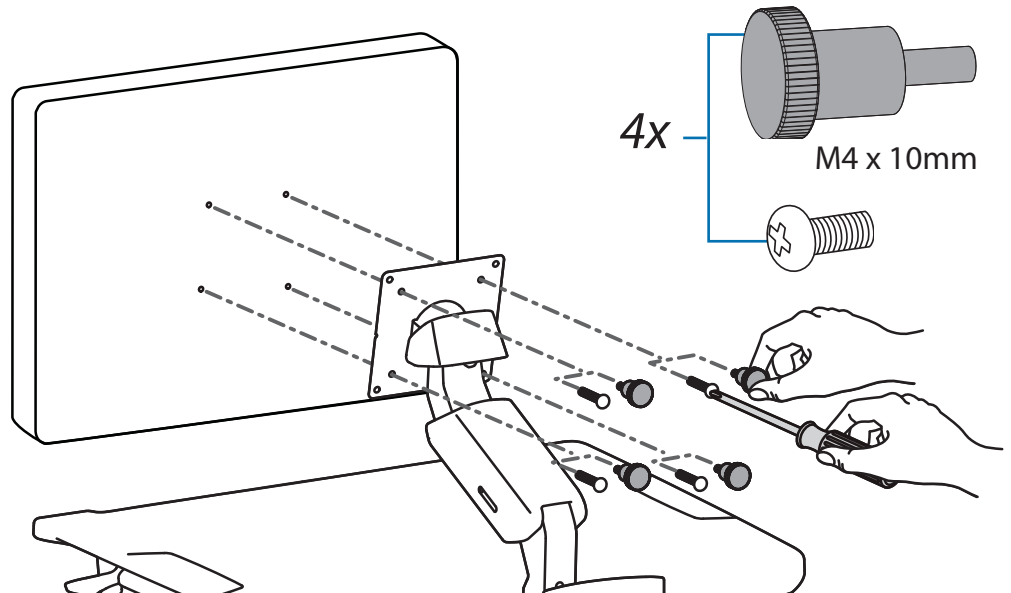

ENGLISH

To increase space and improve airflow, power brick may be stored under the storage area.

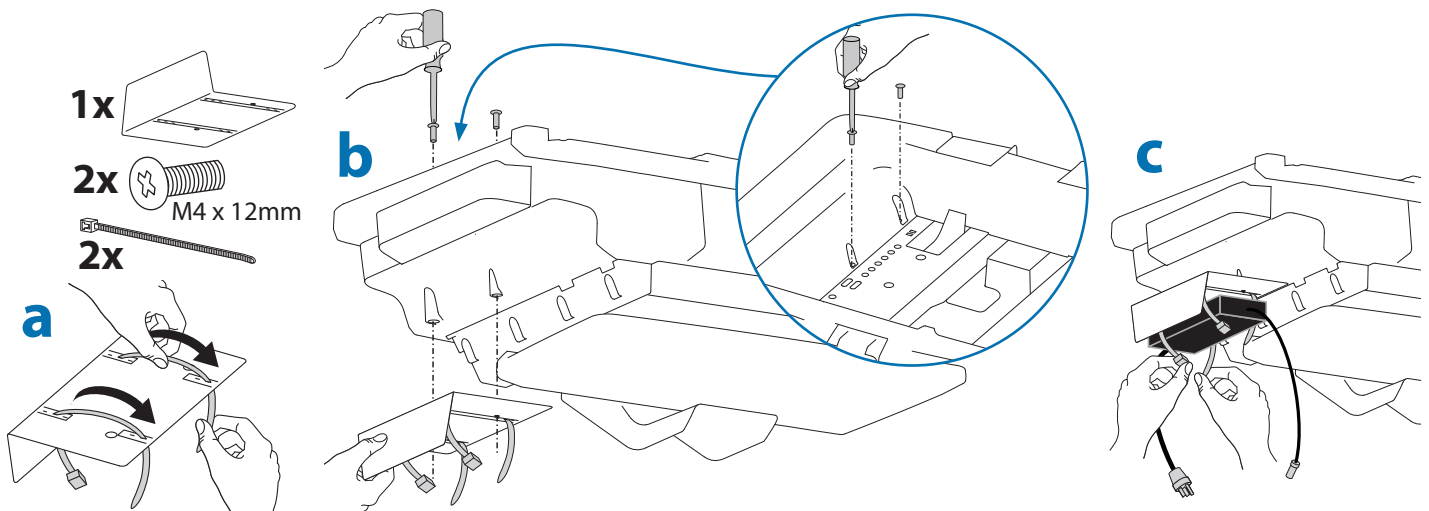

Set-up

5 Plug in power cables.

If you do not have power outlets located here, then follow steps 'a' - 'd' to route power cables.

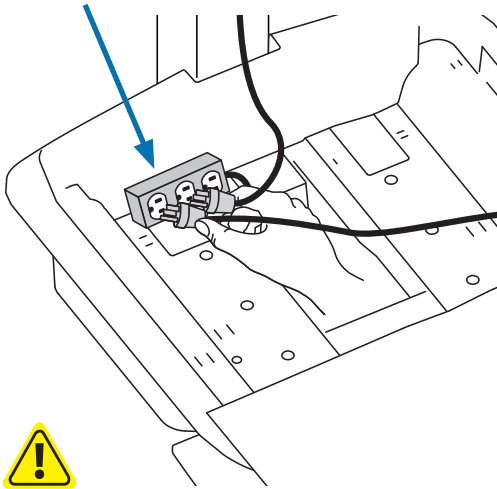

WARNING! Connecting electrical equipment to the outlet effectively leads to creating a medical system and the result can be a reduced level of safety.

a Route power cable down along tower.

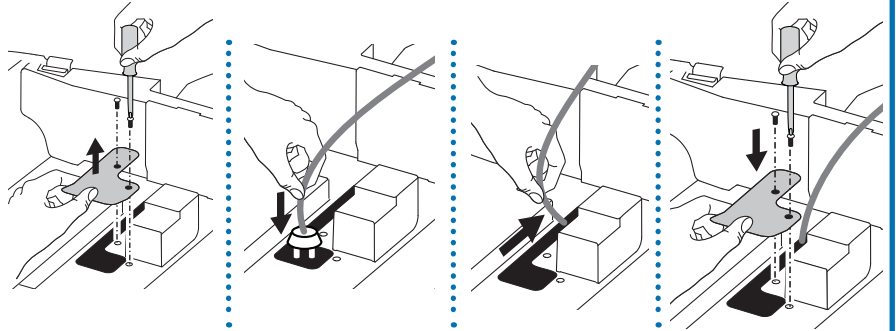
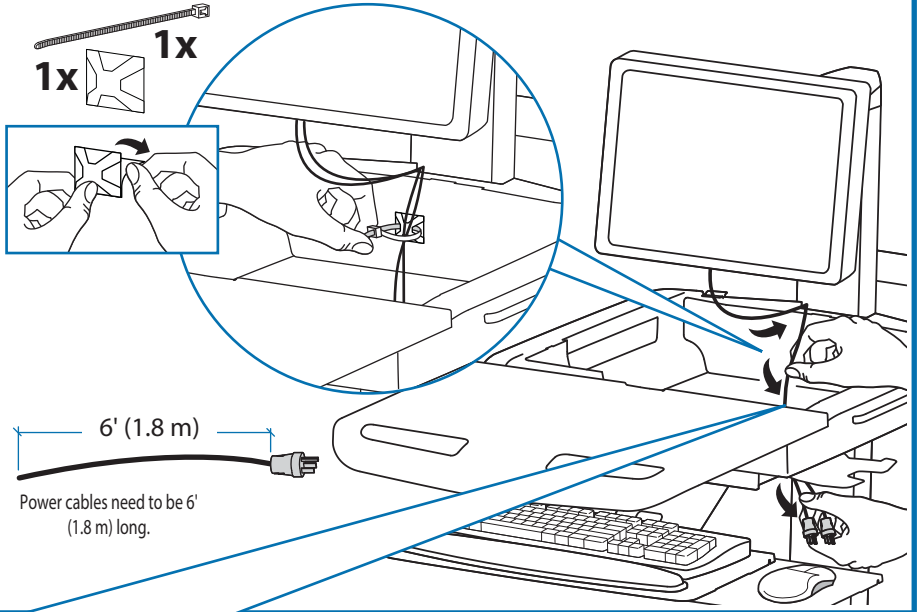

WARNING! DO NOT OPERATE WITHOUT GUARD IN PLACE. Only remove guard when routing a cable with a large connector through the bottom of the compartment. Replace guard immediately after routing cable. Failure to replace guard may result in equipment damage and or personal injury.

b

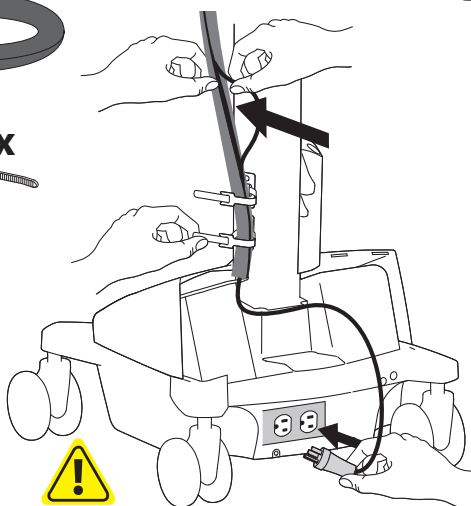
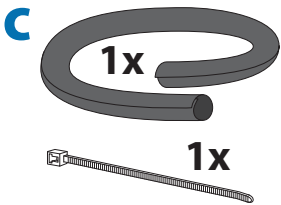
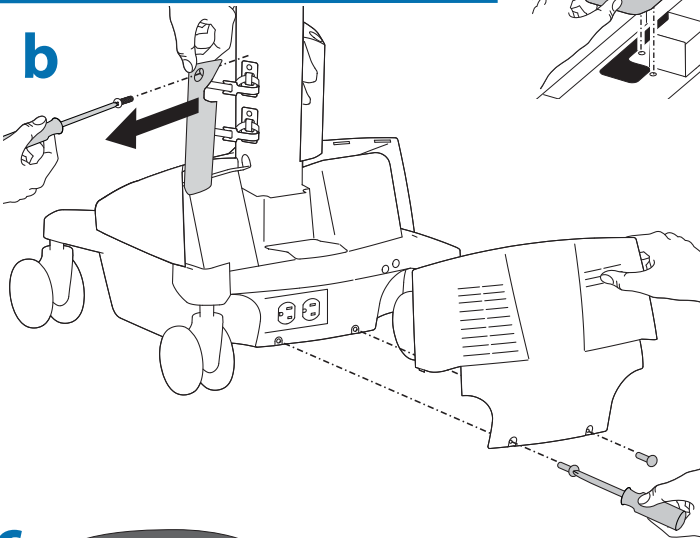

WARNING! Connecting electrical equipment to the outlet effectively leads to creating a medical system and the result can be a reduced level of safety.

d

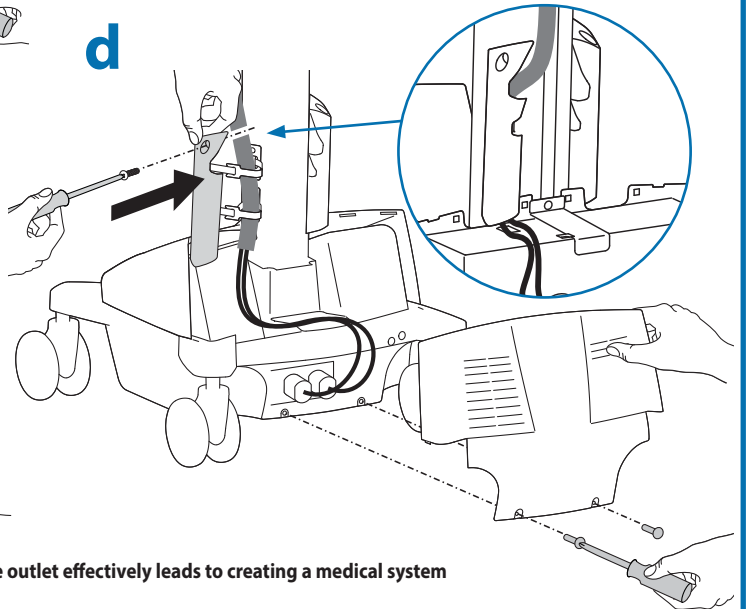

6

Place computer and AC power adaptors in compartment. Do not place power bricks near computer or compartment air vents.

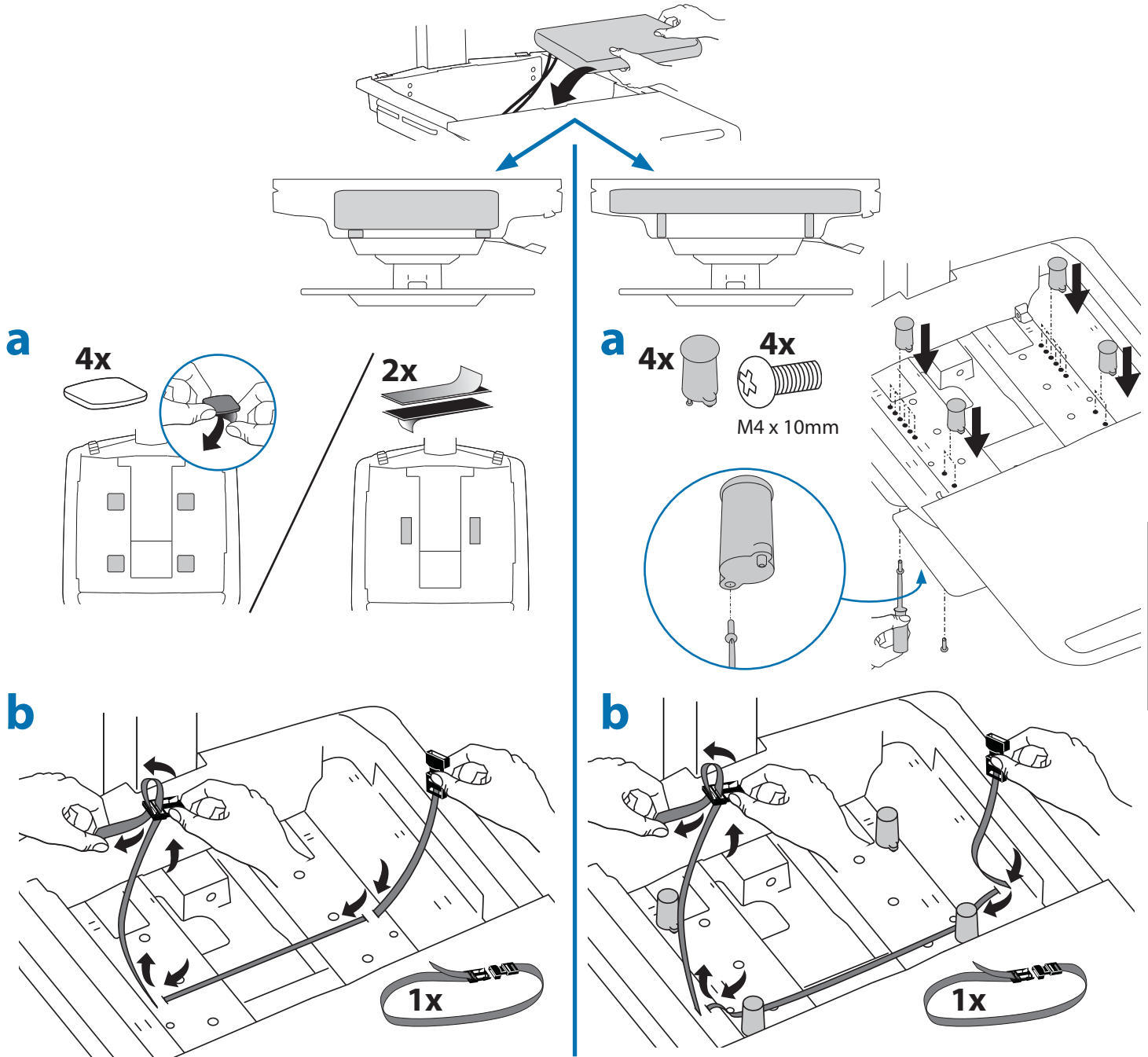

- c** Plug the following factory connected cables into your computer.
- USB:** This cable runs from the USB Hub to your computer and uses your computer to power the USB Hub, Keyboard Lights and Fan. (NOTE: Your computer must be turned on for the USB Hub, Keyboard Lights and Fan to function).
 - Optional StyleLink:** This USB cable runs from the power system to your computer for StyleLink Software. For more info on StyleLink visit: <http://4support.ergotron.com>.

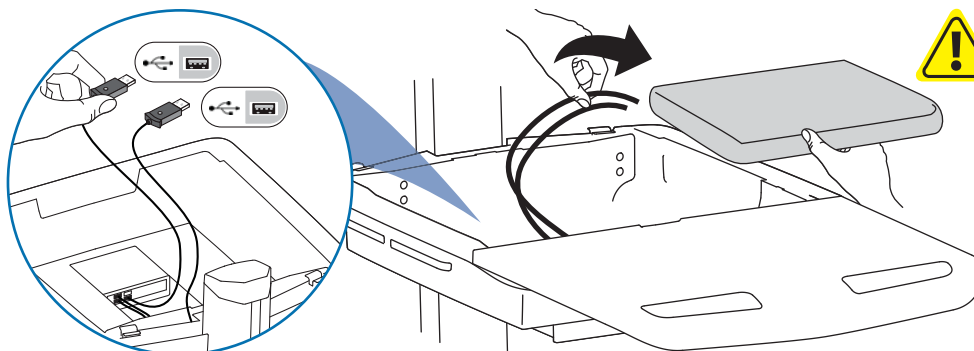

WARNING: Fan must always be running when computer is on. Operating computer without fan may lead to overheating, resulting in reduced equipment performance.

Set-up

d

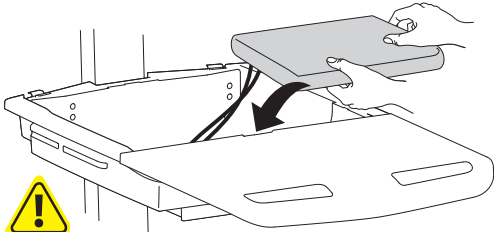

DO NOT OBSTRUCT AIR VENTS!
Obstructing air vents may cause overheating and result in equipment damage.



Placement of CPU's in Secure Storage Area:

USFF (Ultra Small Form Factor)

Thin Client

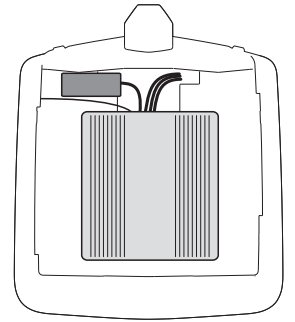
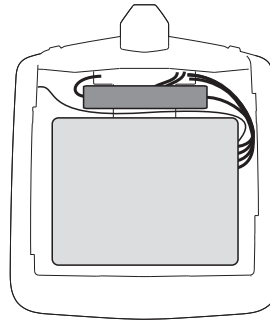

Center CPU in storage area.

To increase space and improve airflow, power brick may be stored under the storage area.

e

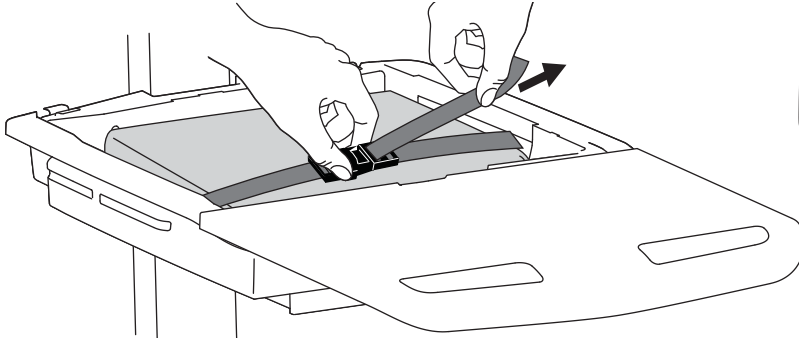

If computer with cables is too wide, then follow these instructions.

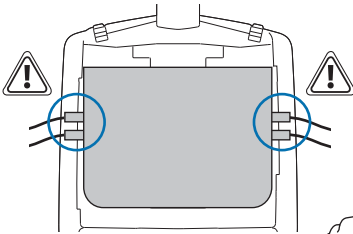

1

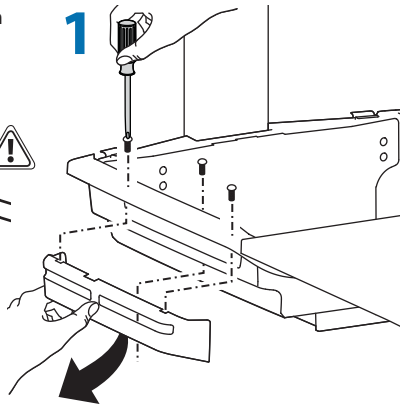

2

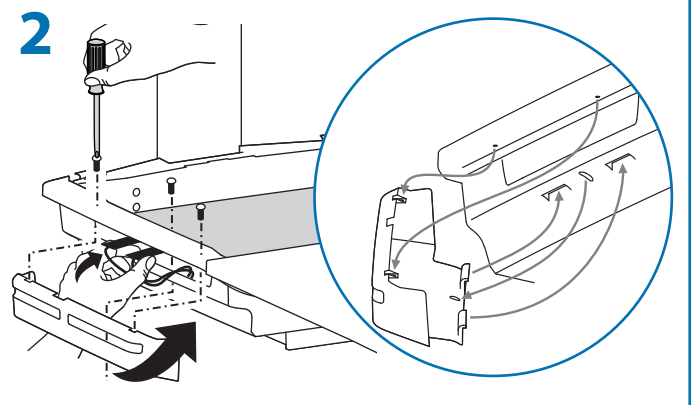

f

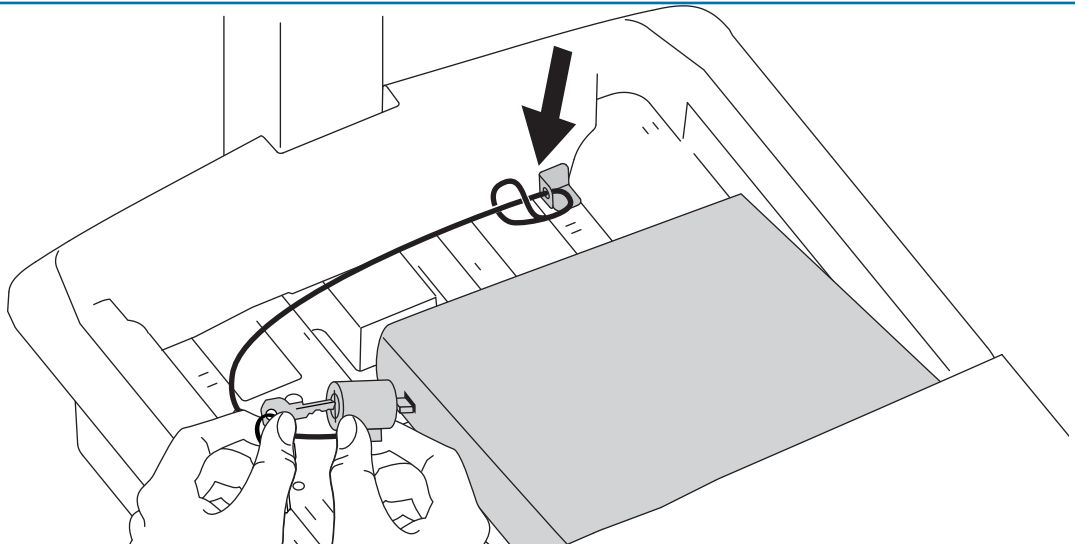
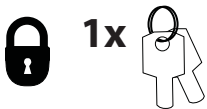

7

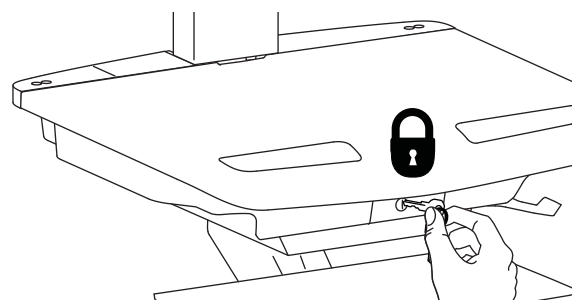
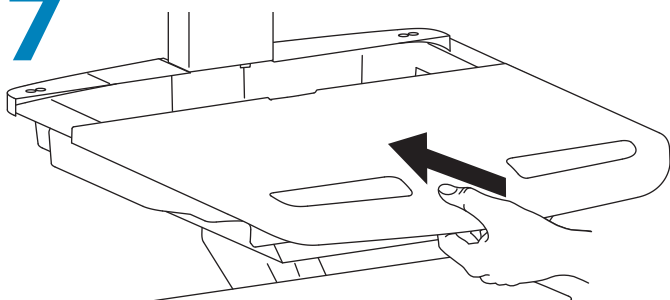

8

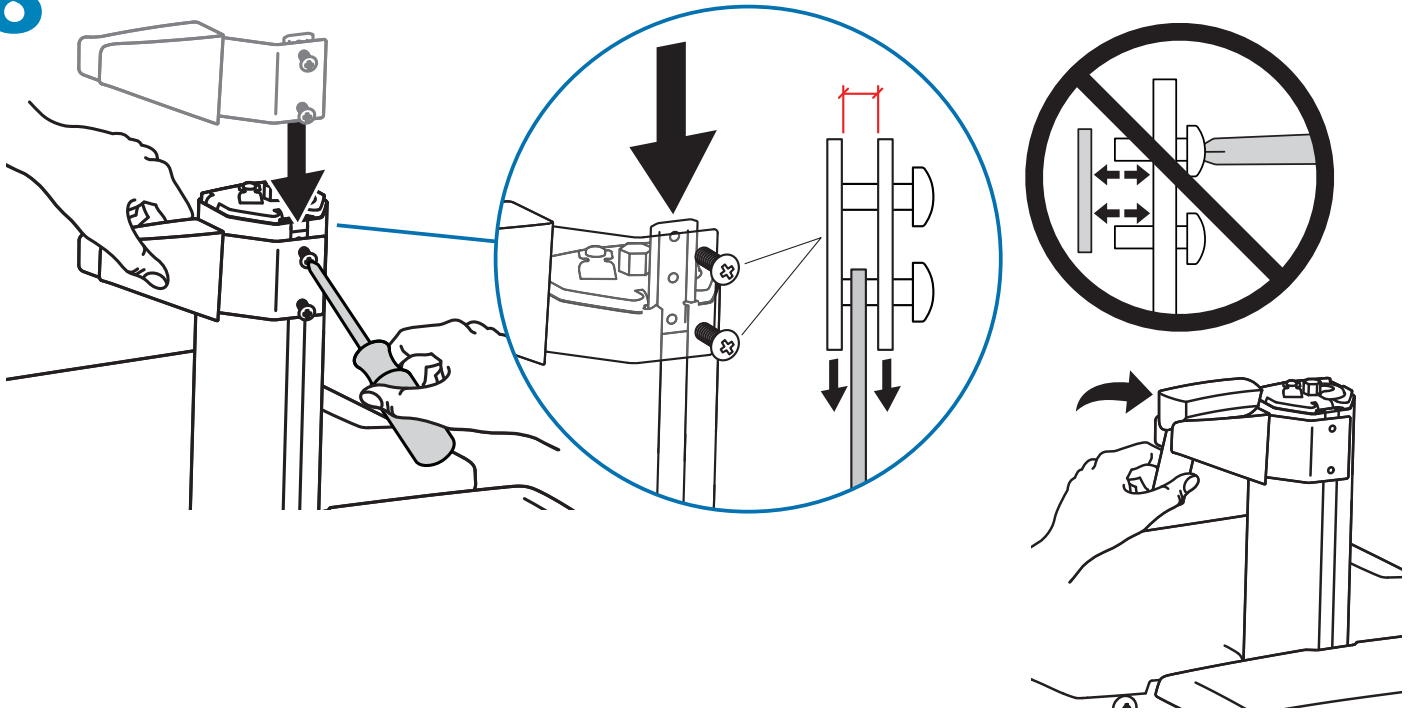

9

1x



1x

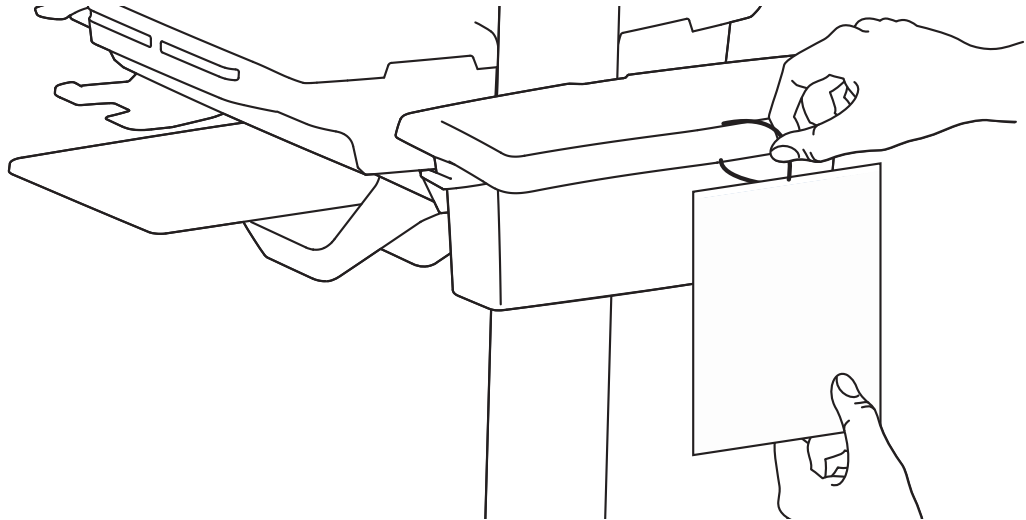

Adjustment

10

It is important that you adjust this product according to the weight of the mounted equipment as described in the following steps. Any time equipment is added or removed from this product, resulting in a change in the weight of the mounted load, you should repeat these adjustment steps to ensure safe and optimum operation. Adjustments should move smoothly and easily through the full range of motion and stay where you set it. If adjustments are difficult and do not stay in the desired position, follow the instructions to loosen or tighten the tension to create a smooth, easy adjustment motion. Depending on your product and the adjustment, it may take several turns to notice a difference.

a Lift – Up and down

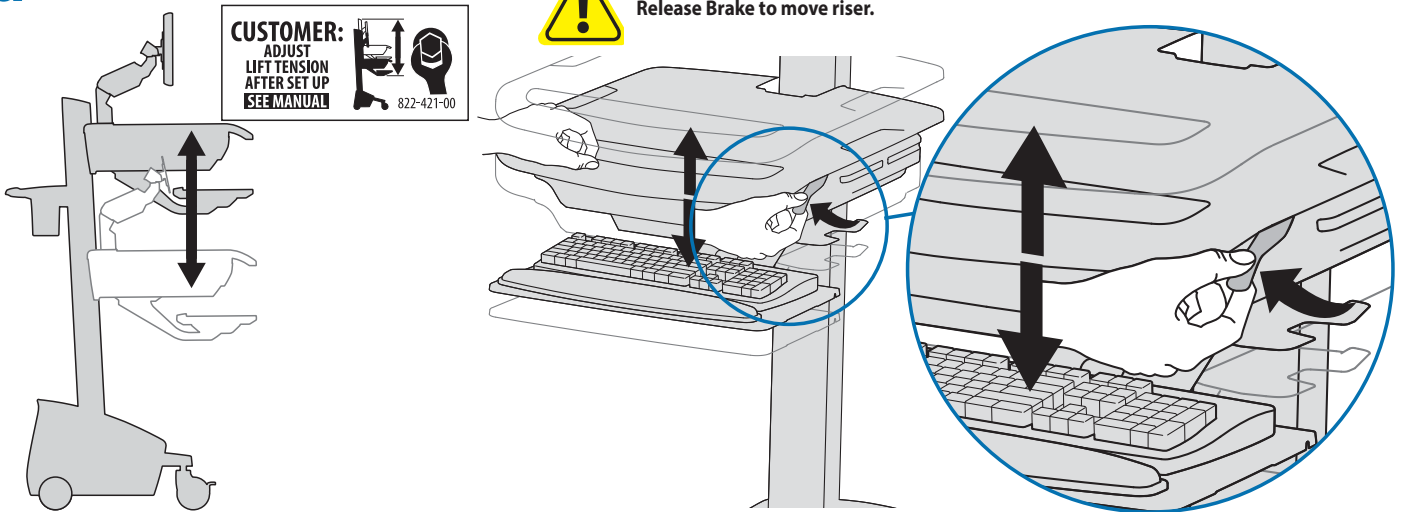

Follow these instructions to tighten or loosen tension.

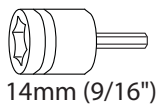

NOTE: Adjustment may require 40 - 60 revolutions.

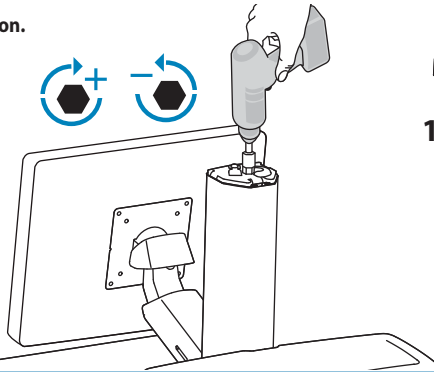

1x
M4 x 8mm

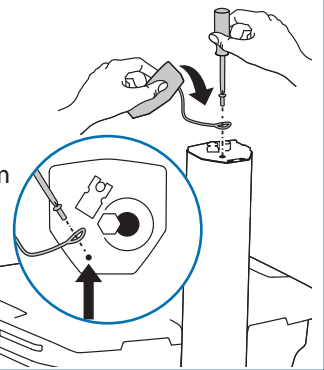

b Tilt – Forward and Backward

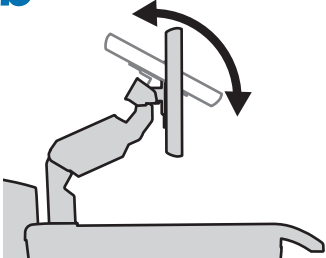

Follow these instructions to tighten or loosen tension.

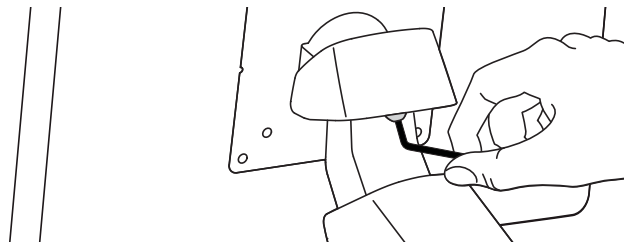

3mm

c Lift – Up and down

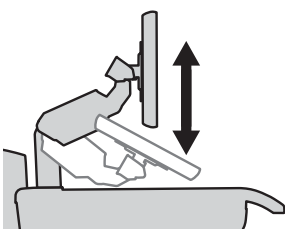

Follow these instructions to tighten or loosen tension.

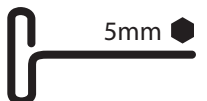
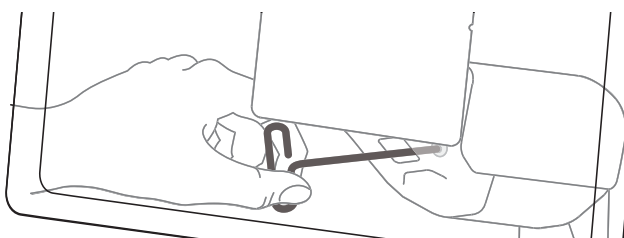

5mm

d Pan – Side-to-side

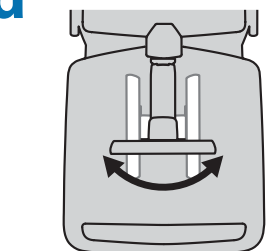

Follow these instructions to tighten or loosen tension.

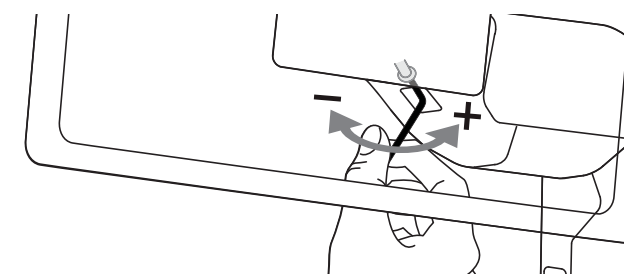

3mm

Battery Charge/Discharge

11 Initial Power on/Charge Battery (takes approximately 2.5 hours to charge)

a Plug Cart's Power Cord into wall outlet.

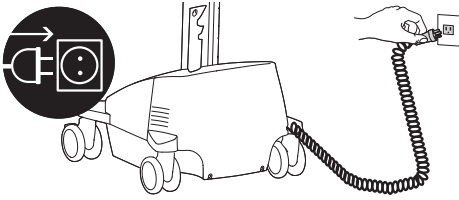

Do Not stretch coiled cord further than 8 feet (2.5 meters), damage to the cord may occur.

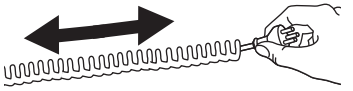

CAUTION: There is no on/off switch on this equipment; the AC power cord is the only power disconnect. The socket outlet should be easily accessible and should be installed near the equipment.

b Turn on power system by holding power button down for 1 - 3 seconds.

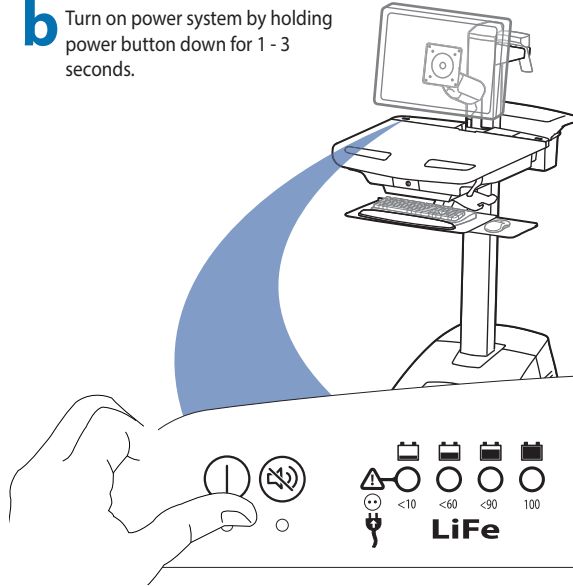

c With cart's power cord plugged into the wall outlet, wait until cart is at 100% charge. (takes approximately up to 2.5 hours to charge)



This power system interface will alert you to the percentage of charge remaining in the cart battery with a series of steady or flashing red, yellow or green lights, and an alarm that will beep when charge gets below 10%. Remember, the battery needs to be charged to 100% every day, and you can use the cart while charging, so plug-in cord as often as possible to avoid running out of power!

NOTE: Put monitor in power save mode to optimize battery run time.

Battery has 100% charge. Light flashes when charging (power cord plugged into wall outlet) Allow battery to continue charging until light stops flashing. After light stops flashing, it is OK to unplug the power cord from the wall. You can use cart while charging.

Battery has less than 90% charge.

Battery has less than 60% charge.

Battery has less than 10% charge and alarm beeps. Light is orange and then turns red when battery has less than 5% charge. Plug-in power cord and charge to 100%! You can use cart while charging.

Alarm Mute button. Pressing this will temporarily mute alarm. When battery has less than 5% charge, the alarm mute is only effective for 1 min.

Power button for internal power system outlets. Pressing this will provide or remove power to/from components plugged into the internal outlets.

If other lights are flashing red/green it could indicate a power system fault. If this occurs contact Ergotron Customer Care.

NOTE: Frequent operation of the cart while battery charge levels are below 10% may reduce the life of your battery.

If the battery is stored too long without recharging, the electronics in the battery may cause the battery voltage to drop too low. If this happens, the power system will enter a low charge recovery mode when plugged into power source.

During the low charge recovery process this light will blink green. This light will be green.

This light will be blinking red. Once the process has finished the power system will resume charging as normal. If the low charge recovery process takes longer than 45 min please contact Ergotron Customer Care.

When lit, alarm is enabled and will beep when battery charge gets below 10%. For details on enabling and disabling alarm contact Ergotron Customer Care.

When lit, the power system is on. When dark, power system is off.

ENGLISH

12 Keyboard Light

1. Turn Computer on.
2. Test Keyboard Light. Keyboard Light will automatically turn off after 15 minutes if not manually turned off.

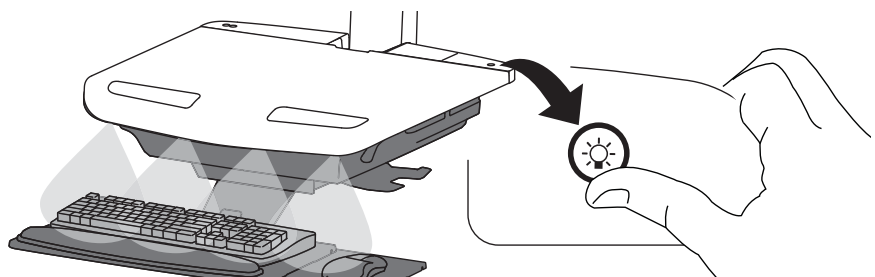

13

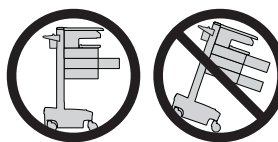
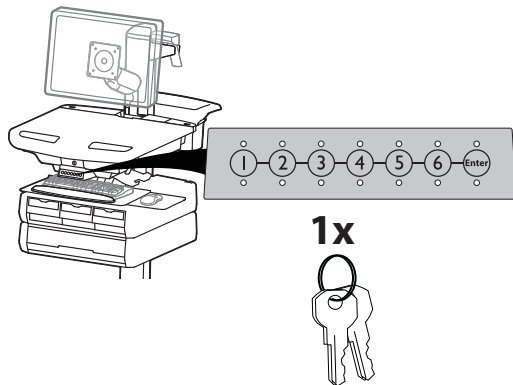

CAUTION: Open only one drawer at a time. Do Not push cart when drawers are open. Failure to follow these instructions may cause the cart to be unstable.

NOTE: Change Master Personal Identification Number (PIN) upon receipt of cart. A User PIN must be created to open drawers electronically.

Ensure that the main power system batteries are installed and functioning. The power does not need to be turned on at the power system user interface.

User PINs:

Without StyleLink management:

- PINs entered on the cart and not managed by StyleLink may vary in length from 4-7 digits.
- Ergotron recommends the following for choosing PIN digit length (assumes less than 1 in 25 chance of guessing random User PIN):
 Max number of User PINs >50, 5+ digit length recommended
 Max number of User PINs >300, 6+ digit length recommended
 For maximum security use PIN length of 7
- Carts store up to 1,000 PINs.

With StyleLink management:

- Maximum 100 PINs per cart.
- 5 digit PIN length required.

Set-up Master PIN for the First Time (Default Master PIN: 12345)

Contact Ergotron Customer Care for instructions if Master PIN is lost.

1. Enter default Master PIN (1-2-3-4-5) then press ENTER.
2. Press 5 for Master PIN change mode
3. Enter new Master PIN and press Enter (LEDs will blink green if PIN is accepted)
4. Master PIN entry mode will exit after 5 seconds of inactivity (LEDs blink red twice)

Master PIN Mode Menu (NOTE: Master PIN does not open drawers.)

Enter Master PIN and then select one of the below numbers to enter that mode

1. After entering Master PIN, Select 1 to access User PIN Entry Mode
2. After entering Master PIN, Select 2 to access Pharmacy PIN Entry/Change Mode
5. After entering Master PIN, Select 5 to access Master Pin Change Mode
- 6, 1. After entering master PIN, select 6 then select 1 to disable alarm. Repeat process to enable alarm.
- 6, 2. After entering master PIN, select 6 then select 2 to enable bulk unlock mode. This will cause all drawers to open when any user PIN is entered. Repeat process to revert back to default.
- 6, 6, Master PIN, Enter. After entering master PIN, select 6 then select 6 again, then enter Master PIN again, then select Enter. This will reset keypad to the factory default Master PIN as 1, 2, 3, 4, 5, and will also delete all User PINs and Pharmacy PIN.

Lost Master PIN

Contact Ergotron Customer Care for instructions.

Programming User PINs

1. Enter Master PIN and press ENTER for Mode Menu.
 2. Press 1 for User PIN Entry Mode.
 3. Input new User PIN and press ENTER (All LEDs blink green if PIN is accepted). You may enter multiple USER PINs consecutively.
 4. User PIN entry mode will exit after 5 seconds of inactivity (LEDs blink red twice).
- NOTE: User PIN cannot be the same as a Master PIN or Pharmacy PIN. Once maximum User PIN storage is exceeded, the oldest User PIN will be over written.

Programming Pharmacy PIN

1. Enter Master PIN and press ENTER for Mode Menu
2. Press 2 for Pharmacy PIN Entry Mode
3. Input Pharmacy PIN and press ENTER (all LEDs blink green in PIN is accepted).
4. Pharmacy PIN entry mode will exit after 5 seconds of inactivity (LEDs blink red twice).

Note: System will hold 1 Pharmacy PIN. Pharmacy PIN allows all drawers to unlock at the same time. Drawers should then be opened at least slightly as the system will auto-lock after 15 seconds. All LEDs will flash green until system auto-locks. Once a drawer is opened the corresponding LED for that row will light solid until it is placed back into its original location.

If drawers are removed from cart for filling, they must be replaced in the same configuration per row. If they are not, power must be removed and reapplied so that the drawer system reconfigures itself.

Auto-Lock Drawer

Unlock Drawer (2 methods): NOTE: All Drawers in row must be closed before a new row can be unlocked.

- Enter User PIN and press ENTER (only numbers for available drawer rows flash green), then press desired drawer row number*.
- Key - turn clockwise 1/4 turn

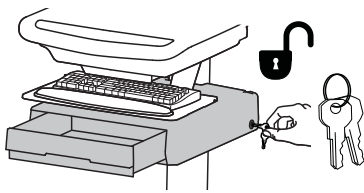
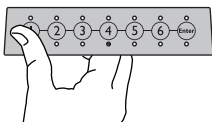

*Drawer Row Numbers:

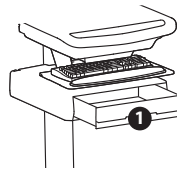

Lock Drawer:

- Wait 4 seconds for lock to engage automatically.

NOTE: Always ensure drawer is pushed in all the way and engaged with lock.

Drawer Troubleshooting

- No LEDs on keypad when pressing any number:
 - Verify DC cable is connected from cart battery harness to controller.
 - Verify keypad cable is connected to controller.
 - Verify circuit breakers are not tripped and 5A fuse is installed in battery harness.
- Drawer selection not available when User PIN is entered:
 - Check to make sure drawer cable is installed securely.
 - Remove power from drawer system for 10 seconds and re-apply.
- LEDs flash red/green after User PIN is entered:
 - Battery charge is low, check to make sure USB charging cable is plugged into computer and computer is ON.

LEDs/Alarm Meaning:

1,2,3,4, or 5 LED ON green: Corresponding Drawer is open.

1,2,3,4, or 5 LED flashing red and alarm sounding: Corresponding Drawer is open longer than 20 seconds. Mute alarm by pressing flashing button corresponding to open drawer.

All available drawer numbers flashing green: Waiting for drawer selection (see Unlock Drawer).

All LEDs blink red twice: PIN entry rejected/exit current mode after 5 seconds timeout.

All LEDs blink green 3 times: PIN entry accepted.

All LEDs flashing red: No drawers connected to controller, check cable.

All LEDs flashing red/green: System power ON or low battery condition.

One or more LEDs flashing red 8 times: Invalid drawer configuration for corresponding drawer row(s). Verify drawers are installed correctly and remove and reapply power.

How to Change Fuse

1 Turn off all mounted equipment.



2 Disconnect Power System from power source.

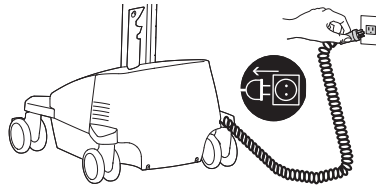

3 Turn power system off by holding down the AC Outlet Power button for 1 - 3 seconds. Power light will shut off.



4

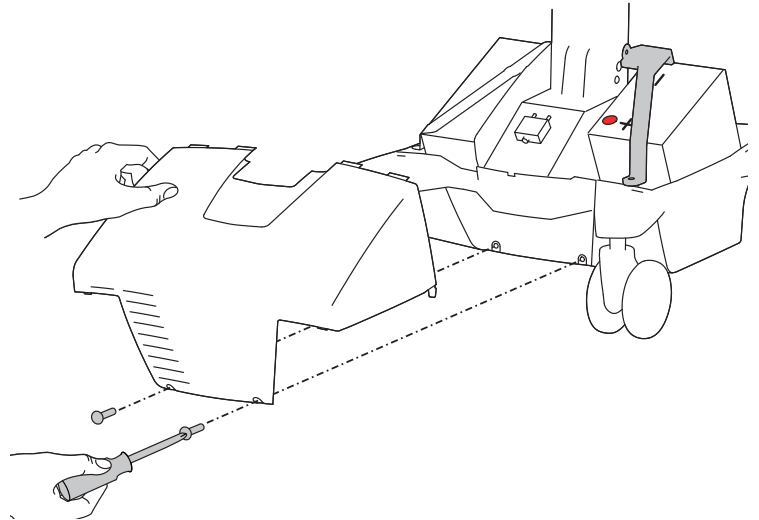
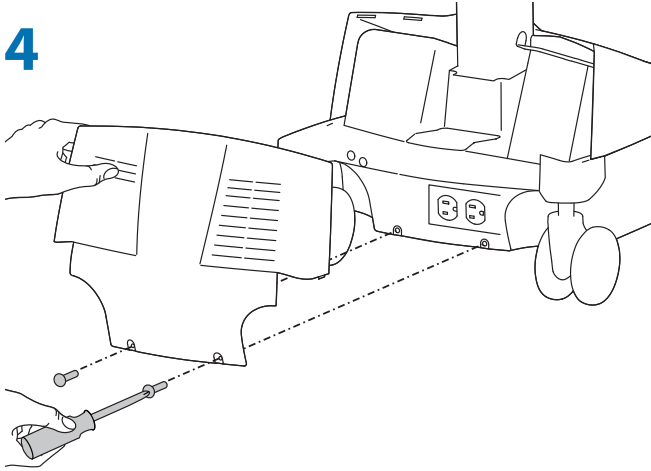

5 5 Amp Fuse

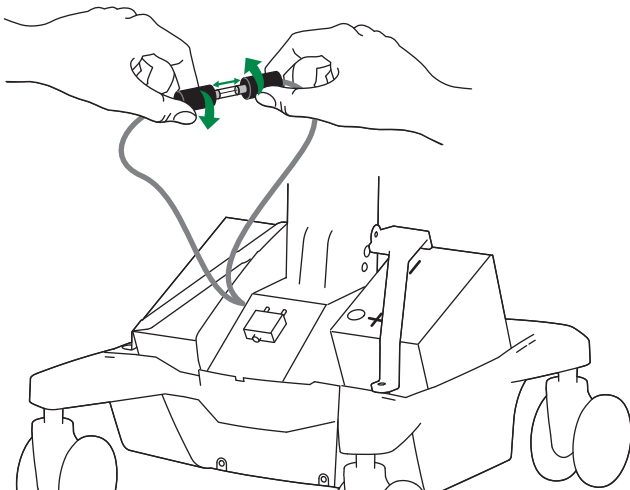

Recommended:
Littelfuse 312005HXP

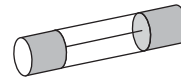

FUSE RATING	
VOLTAGE	250V
CURRENT	5A
OPERATING SPEED	FAST-ACTING
BREAKING CAPACITY	200A @ 250VAC 10000A @125VAC

6

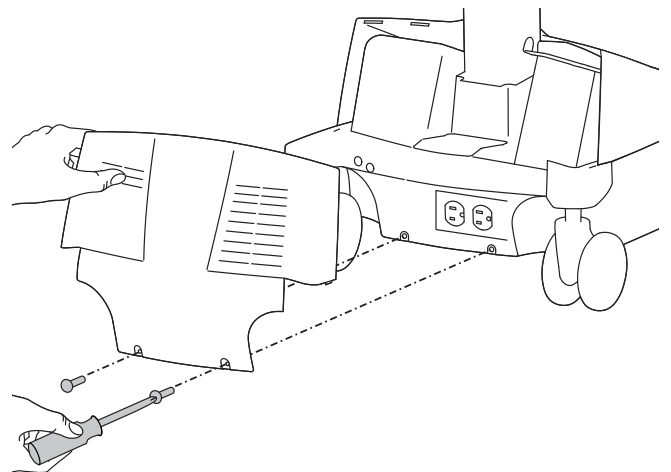
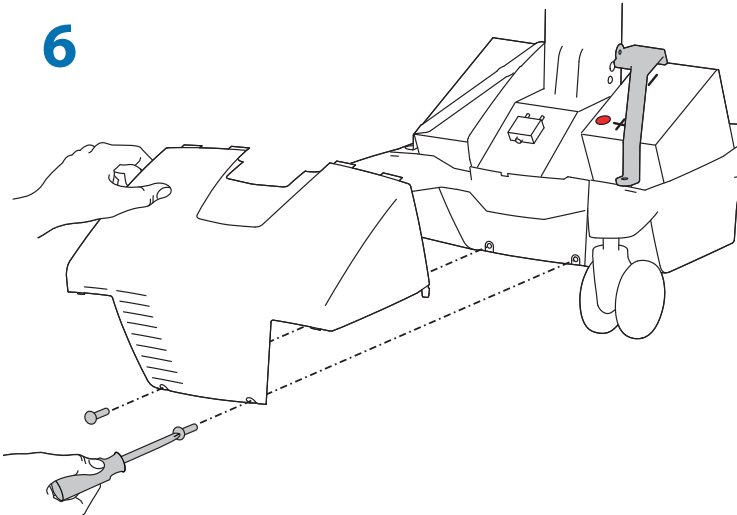

How to Change Power System Battery

⚠ WARNING: RISK OF ELECTRICAL DISCHARGE

- Do NOT swap battery cables, doing so will cause arcing and trip the circuit breaker.
 - Do not remove or replace the batteries while cart is located in an oxygen rich or hazardous environment, arcing may occur and cause combustion.
 - Replace first battery before removing second battery to reduce the risk of cables touching terminals and causing arcing.
- Always replace both batteries!
 - Replace first battery before removing second battery.
 - Replace batteries with same Amp/Hour rating batteries only.
 - Only Ergotron-specified batteries may be used in the StyleView Power System. Please call customer care for more details.
 - Recycle battery or contact Ergotron for proper battery disposal guidelines.



⚠ WARNING/AVERTISSEMENT

BATTERY REPLACEMENT

Only the following 40-Ah lithium batteries are compatible with this system:

Valence Model Number: U1-12RT REV2

Ergotron Part Number: 910-434

Valence Model Number: U1-12RJ

Ergotron Part Number: 915-766

Installing batteries other than the Valence battery listed above will void the product warranty and result in power system malfunction. Failure to heed this warning may result in severe damage to batteries, power module and possible fire hazard.

REEMPLACEMENT DE LA BATTERIE

Seule la batterie suivante est compatible avec ce système :

Batterie au lithium de 40 Ah.

Batterie Valence modèle numéro : U1-12RT REV2

Numéro de pièce Ergotron : 910-434

Batterie Valence modèle numéro : U1-12RJ

Numéro de pièce Ergotron : 915-766

L'installation de toute batterie autre que la batterie Valence indiquée ci-dessus rendra nulle la garantie du produit et entraînera le dysfonctionnement du système d'alimentation. Si vous ne vous conformez pas à cette précaution d'utilisation, les batteries et le module d'alimentation risquent d'être sérieusement endommagés, ce qui pourrait provoquer un incendie.

826-505

1 a Turn off all mounted equipment.

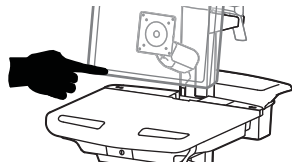

b Disconnect Power System from power source.

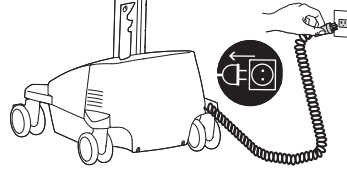

c Turn power system off by holding down the AC Outlet Power button for 1 - 3 seconds. Power light will shut off.



2 a

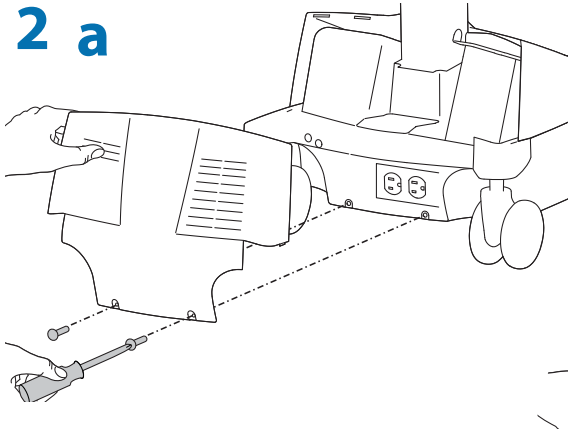

b

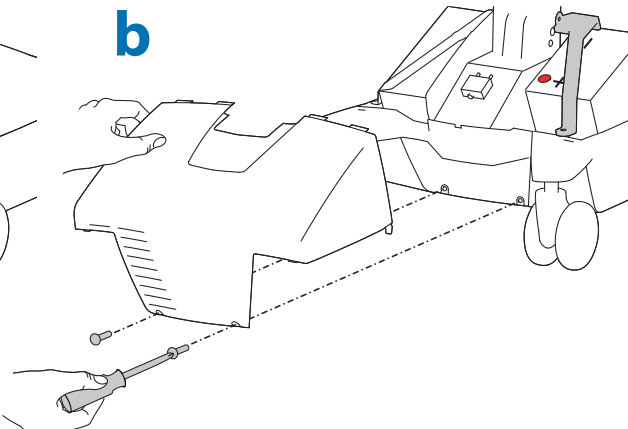

c

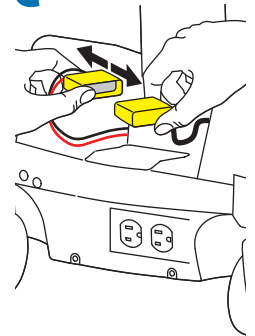

ENGLISH

3 **⚠ Caution: Do NOT swap battery cables, doing so will cause sparking and trip the circuit breaker.**

a

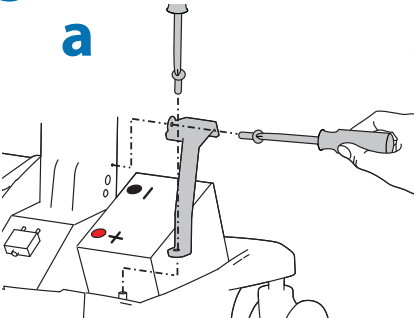

b

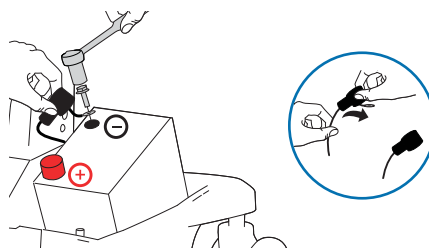

⚠ Caution: Remove Black (-) before removing Red (+).

c

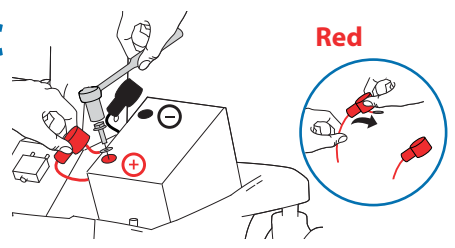

d

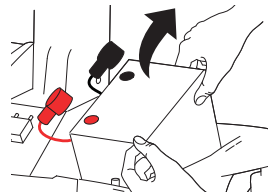

Recycle the battery according to local regulations.

e

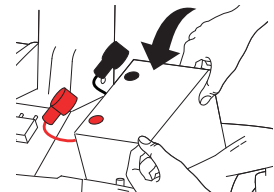

f

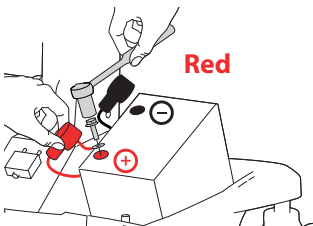

g

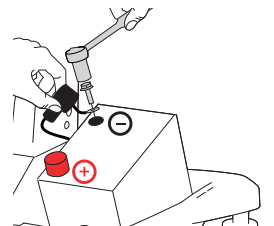

h

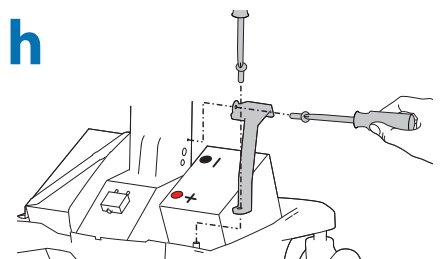

⚠ Caution: Connect Red (+) before connecting Black (-).

How to Change Power System Battery

4 a

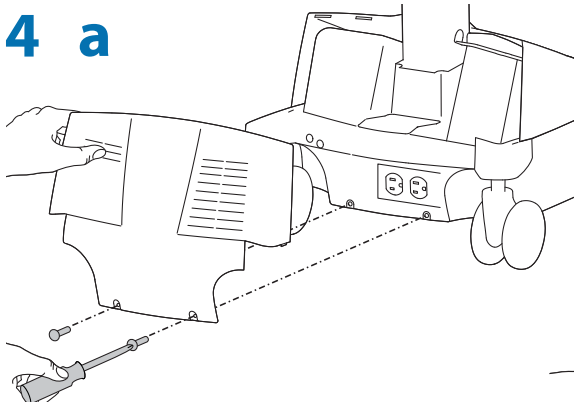

b

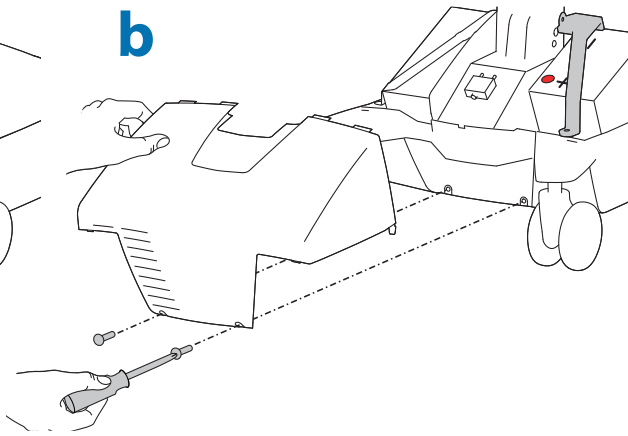

c

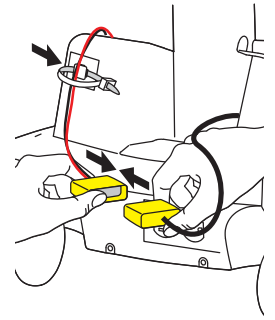

5 Follow Battery Charge/Discharge Initial Power on steps a, b, c.

Cart Storage Instructions

Storage - The battery needs to be fully charged before storing and the battery must be recharged a minimum of every 90 days.

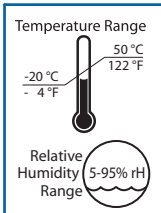

• The recommended cart storage temperature is 25°C (77°F). At this temperature, the battery's age-related capacity loss is minimized. The minimum storage temperature is -20°C (-4°F) and the maximum storage temperature is 50°C (122°F). The recommended humidity range for storage is 5-95% rH.

Storage

1 Turn off all mounted equipment.



2 Plug power cord into appropriate wall outlet to fully charge battery to 100% (all indicator lights will be illuminated). Power system must be fully charged before storing!

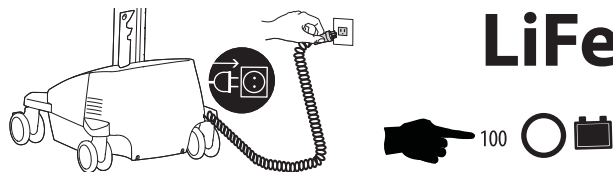

3 Once battery has been charged to 100%, turn power system off.
Turn power system off by holding down the AC Outlet Power button for 1 - 3 seconds. Power light will shut off.

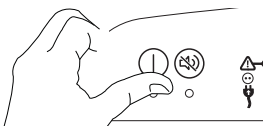

4 Recharge battery a minimum of every 90 days.

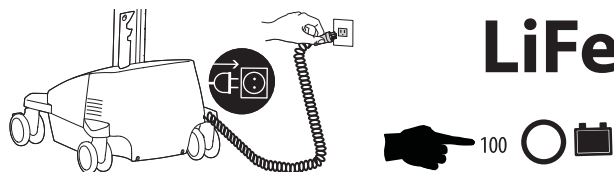

NOTICE:

Warranty on fully charged batteries left in an unused state for more than three (3) consecutive months is automatically void.
Warranty on fully discharged batteries left in an unused state for more than three (3) consecutive days is automatically void.

If the battery is stored too long without recharging, the electronics in the battery may cause the battery voltage to drop to an unsafe level. If this happens, the power system will enter a low charge recovery mode when plugged into power source. Once the process has finished the power system will resume charging as normal. If the low charge recovery process takes longer than 45 min please contact Ergotron Customer Care.

Ergonomics

Working

customize - to your size

- 1 Set top of monitor screen about one inch below eye level - Release brake and lift or lower riser as needed.
- 2 Tilt screen for comfortable viewing and to reduce eye and neck strain.
- 3 Pull keyboard tray forward and position mouse tray on right or left, as needed.
- 4 Work with elbows bent at about 90° to minimize muscle strain.
- 5 If the riser moves up and down with difficulty, or if it drifts out of set position, consult the product manual for adjustment information.
- 6 Stay in charge!
Powered carts should be plugged into outlet as often as possible to keep battery charged and computer running.

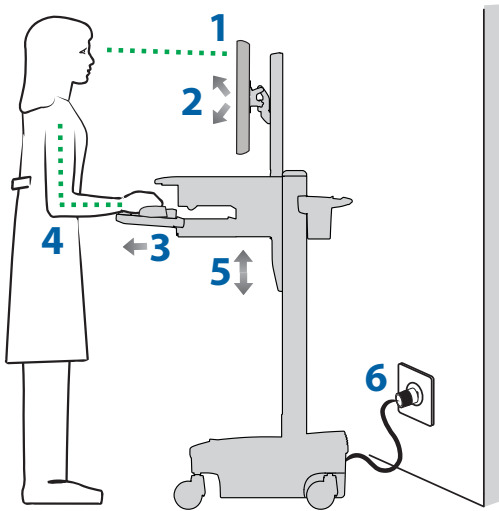

Moving

stow - before you go

- 1 During normal movement, release brake and lower worksurface to lowest position for optimal stability and unobstructed view.
- 2 Tuck away open trays and return mouse, scanner and other accessories to their places. Clear worksurface
- 3 Unlock both front casters.
- 4 Push cart from rear with elbows bent at about 90° to maximize control and minimize muscle strain.
- 5 Don't run out!
Before moving, make sure cord is unplugged from outlet and hooked to basket for safe travel. Remember, charge battery fully 100% every day!

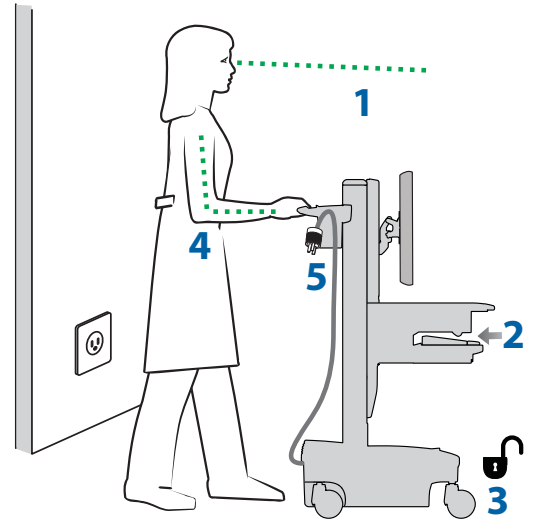

Maintenance & Safety

Hazard Symbols Review

The Meaning of Symbols appearing in this Guide, on the Cart or on the Power System. These symbols alert you to a safety condition that demands your attention. You should be able to recognize and understand the significance of the following Safety Hazards if you encounter them on the Cart or within Cart documentation such as this Set-up Guide.

Symbol	Signal Word/ Color	Level of Hazard
	DANGER	Indicates an imminently hazardous situation which, if not avoided, will result in death or serious injury.
	WARNING	Indicates a potentially hazardous situation which, if not avoided, could result in death or serious injury.
	CAUTION	Indicates a potentially hazardous situation which, if not avoided, may result in minor or moderate injury.
	CAUTION	Used without the safety alert symbol indicates a potentially hazardous situation which, if not avoided, may result in property damage.
	INSTRUCTIONS	Follow operating instructions.
	INSTRUCTIONS	Follow operating instructions.
	POWER	"ON" / "OFF" (push-push) NOTE: Each position "ON" / "OFF" is a stable position.



EQUIPMENT & ACCESSORIES DISPOSAL

1. Please dispose of all batteries in accordance with local law
2. All Electronics should be recycled through an electronics recycler.
3. Remaining plastics and metals can be recycled through a commercial recycler.

Maintenance & Safety

Cleaning and Maintenance

The following procedures are not guaranteed to control infection. The hospital infection control administrator or epidemiologist should be consulted regarding cleaning procedures and processes.

 To avoid risk of electric shock, do not expose electrical components to water, cleaning solutions or other potentially corrosive liquids or substances.

 Do not immerse Cart or Cart components in liquid or allow liquids to flow into the Cart. Wipe all cleaners off surface immediately using a damp cloth. Thoroughly dry surface after cleaning.

 Do not use flammable cleaners on Cart surfaces due to close proximity of electrical power and equipment.

All paints and plastic Cart components will withstand cleaning by most commonly used, diluted, non-abrasive solutions such as quaternary ammonia compounds, ammonia enzyme cleaners, bleach or alcohol solutions.

- Pen and permanent and dry erase markers can be removed with 91% isopropyl alcohol and a soft cloth.
- Iodine stains can be removed with commonly used cleaners and a soft cloth.
- Never use steel wool or other abrasive materials that will damage the surface finish.
- Do not use strong solvents such as trichloroethylene and acetone. These solvents will damage the surface finish.

It is recommended that any cleaning solution be tested on a small, inconspicuous area to ensure surface is not harmed.

 Adjustment, Service, Replacement - DO NOT attempt to adjust, service or replace any part of the StyleView Cart unless directed to do so through Ergotron-approved documentation (i.e. installation instructions). Only Ergotron, Inc. or an Ergotron-certified entity may adjust, service or replace StyleView Cart components. If any component on the Cart is missing or damaged, the Cart must not be used, contact Ergotron Customer Care immediately to request a replacement part.

 Cables - Keep cables neatly organized on the Cart (a variety of solutions are provided with your cart for this purpose). Excess cables should be routed away from moving components with cable clips. Review Cable Routing section of this guide, or contact Ergotron Customer Care for more information.

 Casters - Check casters periodically to make sure they are clean and free of debris that would prevent smooth travel. Avoid moving Cart across uneven, dirty or damaged surfaces.

 Customer Equipment- Make sure equipment is balanced and mounted securely to Cart. Do not reposition Cart components on riser or tower unless instructed to do so in the installation instructions. Moving Cart components too high or too low on the Riser may create an unstable condition, leading to equipment damage or even personal injury. Contact Ergotron Customer Care for information about moving Cart components.

 WARNING: In rare cases, if the power system and battery protection features fail, the battery may become overcharged and in some instances it may become extremely hot, possibly melting the plastics and releasing smoke. If a battery begins to smoke or melt:

- Unplug the cart, or if possible disconnect the battery from the power system immediately.
- Move the cart to a well ventilated area.
- Use a Carbon Dioxide, Dry Chemical or appropriate foam fire extinguisher to spray the hot battery.

If a fire extinguisher is not available, use copious amounts of water, or cover the battery with sand.

If exposed to battery contents seek immediate medical attention and follow the below guidelines.

Exposure to vapor released from the battery is irritating to the eyes, skin, mucous membranes and respiratory tract. This may cause nausea, dizziness and headache.

In case of direct contact to the battery's electrolyte:

- Immediately flush eyes with water for at least 15 minutes.
- Thoroughly rinse hands and other affected areas with water.
- Promptly remove and wash any contaminated clothing.

In All Cases, Seek Immediate Medical Attention!

Safety Alerts Associated with this Product

The following Warnings/Cautions appear in this reference guide or on the cart:

NOTE: Failure to adhere to these guidelines may result in equipment damage or personal injury.

 CAUTION: The lift brake helps stabilize the worksurface and keyboard tray during normal use but it DOES NOT increase load capacity. DO NOT load riser with equipment totaling more than the maximum weight capacity specified by Ergotron. Ensure optimum lift function by testing and if necessary, re-adjusting tension whenever the weight mounted to the riser changes (i.e., equipment is removed or added). See "Set Riser Lift Tension" adjustment instructions.

 CAUTION: Do not operate StyleView Cart with missing or damaged components! Do not remove, modify or substitute Cart components without consulting Ergotron. If you encounter problems with Cart installation or operation, contact Ergotron Customer Care.

 CAUTION: DO NOT overtighten fasteners. Overtightening may cause damage to your equipment.

 WARNING: Stored Energy Hazard: The worksurface lift mechanism is under tension and will move up rapidly, on its own, as soon as attached equipment is removed. For this reason, DO NOT remove equipment unless the worksurface has been moved to the highest position on the tower! Failure to follow this instruction may result in serious personal injury and/or equipment damage! When Shipping the cart, set the worksurface lift mechanism to the lowest tension setting.

 CAUTION: DO NOT loosen, tighten or remove any other nuts or bolts on the riser or top of tower. Tampering with nuts or bolts may result in an unstable Cart, leading to equipment damage and/or personal injury.

 CAUTION: Release Lift Brake before moving work surface! Moving work surface while Lift Brake is engaged may cause serious damage to Lift Engine.

 WARNING: In the event that repair of the StyleView Cart is needed, contact Ergotron Customer Care immediately. Cart repair can only be performed by Ergotron, Inc. or by an Ergotron authorized agent.

 WARNING: This cart is not intended for use in a flammable, anesthetic mixture or oxygen rich environment.

Configuration & Safety

 Additional multiple socket-outlet or extension cord shall not be connected to the medical system.

 When used in a Medical Electrical system, connect only equipment that complies with IEC, ISO, UL/ANSI, or CSA standards that are relevant to that equipment.

 Risk of shock or personal injury when connecting non-medical equipment supplied as part of a system directly to the wall outlet when non-medical equipment is intended to be supplied by the multiple socket outlet.

 Risk of shock or personal injury when connecting any equipment that has not been supplied as part of the medical system to the multiple socket outlet.

Recommended Periodic Inspection and Maintenance			
Component	Action	How often	By whom
UI, Ethernet, USB cables	Inspect for wear, pinching, bad connectors	Monthly	Any user
Fan on side of CPU compartment	Inspect for dust at intake, vacuum as required using a vacuum cleaner that DOES NOT generate ESD (Electrostatic Discharge)	Monthly	Any user
Casters	Inspect for wear and debris	Monthly	Any user
Maximum Load	Inspect to ensure that maximum recommended loads are not exceeded	Daily	Any user
Power System batteries	Replace lithium battery ^{1,2}	When battery runtime is 60% of original runtime	IT Personnel
Power Module	Inspect for dust at intake, vacuum as required using a vacuum cleaner that DOES NOT generate ESD (Electrostatic Discharge)	Monthly	IT Personnel
Battery harness	Inspect for wear, cracking, pinching, or other damage	Monthly	IT Personnel
Coiled Cord	Inspect for wear, damage, or stretching	Weekly	Any user

1. Please dispose of all batteries in accordance with local law.
2. Always replace battery with approved Valence battery.

Earth Bond Test: To ensure safety grounding between the power cord ground connection and any accessible metal parts on the cart, although not mandatory, the following test is recommended to be performed every two years using a calibrated medical device safety analyzer. The procedure is as follows:

1. Disconnect the cart from mains power (unplug cart from the wall).
2. Remove power from internal power system outlets by pressing the power button on the Power System Interface.
3. Set up Earth Bond Test per the medical device safety analyzer instructions.
4. Connect the Cart power cord to the medical device safety analyzer.
5. Remove cover to access Lift Tension Adjustment point.
6. Attach second medical safety device analyzer probe to Lift Tension Adjustment point on Cart.
7. Perform Test (25 amps).
8. Ensure Earth Bond is less than or equal to 0.2-ohms.
9. Remove medical device safety analyzer connections to Cart, replace cover over Lift Tension Adjustment point, return the Cart to service.

Insulation Resistance Test: To ensure mains power lines are adequately insulated from earth ground, the following test, although not mandatory, is recommended to be performed annually using a calibrated medical device safety analyzer. The procedure is as follows:

1. Disconnect the cart from mains power (unplug cart from the wall).
2. Remove power from internal power system outlets by pressing the power button on the Power System Interface.
3. Set up the Insulation Resistance Test per the medical device safety analyzer instructions.
4. Connect the Cart power cord to the medical device safety analyzer.
5. Perform test (500 V).
6. Ensure Insulation Resistance is greater than or equal to 1 Mohms.
7. Remove medical device safety analyzer connections to Cart and return Cart to service.

⚠ DANGER!



ELECTRICAL CORDS CAN BE HAZARDOUS
Misuse Can Result in FIRE or DEATH by ELECTRICAL SHOCK.

LES CORDONS ELECTRIQUES PEUVENT ETRE DANGEREUX
Une mauvaise utilisation peut provoquer un INCENDIE ou la MORT par CHOC ELECTRIQUE.

820-672 Please Read and Follow Product Manual Instructions.

THIS IS A POLARIZED CORD - HOSPITAL GRADE ONLY
NOTE: Grounding Reliability Can Only Be Achieved When the Equipment Is Connected To An Equivalent Receptacle Marked "HOSPITAL ONLY" Or "HOSPITAL GRADE"

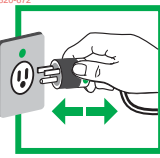
820-672

- Inspect Cord Thoroughly Before Each Use. DO NOT USE IF DAMAGED.
- Do Not Plug More Than SPECIFIED NUMBER OF WATTS Into Power System.
- Do Not Run Cord Through Doorways, Holes in Ceilings, Walls or Floors.
- FULLY INSERT Plug Into Outlet.
- Do Not Remove, Bend or Modify Any Metal Prongs or Pins of Cord.
- Do Not Use Excessive Force to Make Connections.
- Keep Away From Water. DO NOT USE WHEN WET.
- Keep Children Away From Cord.
- Do Not Plug Cord into An Extension Cord.
- AVOID OVERHEATING. Uncoil Cord and Do Not Cover It With Any Material.
- Do Not Drive, Drag or Place Objects Over Cord. Do Not Walk On Cord.
- GRASP PLUG TO REMOVE FROM Outlet. Do Not Unplug By Pulling On Cord.

Maintenance & Safety

Ergotron Electromagnetic Guidance and Manufacturer's Declaration

Guidance and Manufacturer's Declaration – Electromagnetic Emissions		
The Powered Computer Cart is intended for use in the electromagnetic environment specified below. The customer or the user of the Powered Computer Cart should assure that it is used in such an environment.		
Emissions Test	Compliance	Electromagnetic environment – guidance
RF Emissions CISPR 11	Group 1	The Powered Computer Cart uses RF energy only for its internal function. Therefore, its RF emissions are very low and unlikely to cause any interference in nearby electronic equipment.
RF Emissions CISPR 11	Class A	The Powered Computer Cart is suitable for use in all establishments other than domestic and those directly connected to the public low-voltage power supply network that supplies buildings used for domestic purposes.
Harmonic Emissions IEC 61000-3-2	Class A	
Voltage fluctuations/ flicker emissions IEC 61000-3-3	Complies	

Guidance and Manufacturer's Declaration – Electromagnetic Immunity			
The Powered Computer Cart is intended for use in the electromagnetic environment specified below. The customer or the user of the Powered Computer Cart should assure that it is used in such an environment.			
Immunity Test	IEC 60601 Test Level	Compliance Level	Electromagnetic environment - guidance
Electrostatic Discharge (ESD) IEC 61000-4-2	±6 kV contact ±8 kV air	Complies	Floors should be wood, concrete, or ceramic tile. If floors are covered with synthetic material, the relative humidity should be at least 30%
Electrical Fast Transient/Burst IEC 61000-4-3	±2 kV for power supply lines ±1 kV for input/output lines	Complies	Mains power quality should be that of a typical commercial or hospital environment.
Surge IEC 61000-4-5	±1 kV differential mode ±2 kV common mode	Complies	Mains power quality should be that of a typical commercial or hospital environment
Voltage Dips, short interruptions, and voltage variations on power supply input lines IEC 61000-4-11	<5% U_T (>95% dip in U_T) for 0.5 cycle 40% U_T (60% dip in U_T) for 5 cycles 70% U_T (30% dip in U_T) for 25 cycles <5% U_T (>95% dip in U_T) for 5 seconds	Complies	Mains power quality should be that of a typical commercial or hospital environment.
Power Frequency (50/60 Hz) Magnetic Field IEC 61000-4-8	3 A/m	Complies	Power frequency magnetic fields should be at levels characteristic of a typical commercial or hospital environment.
Note: U_T is the AC mains voltage prior to application of the test level			

ENGLISH

Americas Sales and Corporate Headquarters

1181 Trapp Rd.
St. Paul, MN USA
(800) 888-8458
+1-651-681-7600
www.ergotron.com
sales@ergotron.com

EMEA Sales

Amersfoort, The Netherlands
+31 33 45 45 600
www.ergotron.com
info.eu@ergotron.com

APAC Sales

Tokyo, Japan
www.ergotron.com
apaccustomerservice@ergotron.com

Worldwide OEM Sales

www.ergotron.com
info.oem@ergotron.com



205 Westwood Ave, Long Branch, NJ 07740
Phone: 866-94 BOARDS (26273) / (732)-222-1511
Fax: (732)-222-7088 | E-mail: sales@touchboards.com

ERGOTRON®

While Ergotron, Inc. makes every effort to provide accurate and complete information on the installation and use of its products, it will not be held liable for any editorial errors or omissions (including those made in the process of translation from English to another language), or for incidental, special or consequential damages of any nature resulting from furnishing this instruction and performance of equipment in connection with this instruction. Ergotron, Inc. reserves the right to make changes in the product design and/or product documentation without notification to its users. For the most current product information, or to know if this document is available in languages other than those herein, please contact Ergotron. No part of this publication may be reproduced, stored in a retrieval system, or transmitted in any form or by any means, electronic, mechanical, photocopying, recording or otherwise without the prior written consent of Ergotron, Inc., 1181 Trapp Road, Eagan, Minnesota, 55121, USA. Patents Pending and Patented U.S. & Foreign. Ergotron is a registered trademark of Ergotron, Inc.