

ERGOTRON®
WorkFit-P
Sit-stand height adjustable workstation

Touchboards
205 Westwood Ave, Long Branch, NJ 07740
Phone: 866-94 BOARDS (26273) / (732)-222-1511
Fax: (732)-222-7088 | E-mail: sales@touchboards.com



ENGLISH

For the latest User Installation Guide please visit: www.ergotron.com

User's Guide - English
Guía del usuario - Español
Manuel de l'utilisateur - Français
Gebruikersgids - Deutsch
Benutzerhandbuch - Nederlands
Guida per l'utente - Italiano
Användarhandbok - svenska
ユーザーガイド：日本語
用户指南：汉语

For local customer care phone numbers visit: <http://contact.ergotron.com>

888-45-307-G-01 rev. F • 11/13

 www.ergotron.com
USA 1-800-888-8458
Europe +31 (0)33-45 45 600
China 86-769-86018920

Important! You will need to adjust this product after installation is complete. Make sure all your equipment is properly installed on the product before attempting adjustments. This product should move smoothly and easily through the full range of motion and stay where you set it. If movements are too easy or difficult or if product does not stay in desired positions, follow the adjustment instructions to create smooth and easy movements. Depending on your product and the adjustment, it may take many turns to notice a difference. Any time equipment is added or removed from this product, resulting in a change in the weight of the mounted load, you should repeat these adjustment steps to ensure safe and optimum operation.

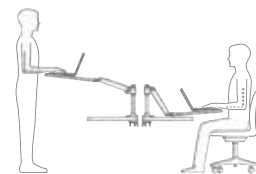

 **CAUTION!** Max weight 10 lbs (4.5 kg). Do not exceed maximum listed weight capacity. Serious injury or property damage may occur!

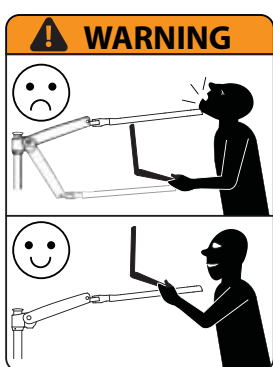

WARNING! Stored Energy Hazard: The arm mechanism is under tension and will move up rapidly, on its own, as soon as attached equipment is removed. For this reason, **DO NOT** remove equipment unless the arm has been moved to the highest position! Failure to follow this instruction may result in serious personal injury and/or equipment damage!



Warning! Do not move arm until Lock is installed in the next step. Failure to follow these instructions may result in your arm coming off the pole base and causing equipment damage and/or personal injury.



Warning! Remove arm from pole base before removing clamp or grommet hole mount from desk. Failure to follow these instructions may result in the arm falling over causing equipment damage and/or personal injury.

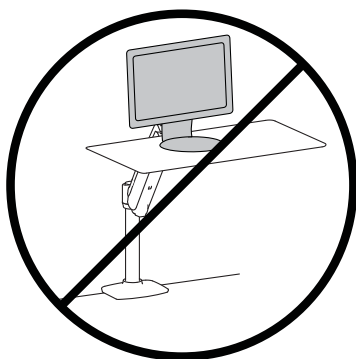

Warning! Do not use with LCD on platform. Failure to follow these instructions will create an unstable situation and may result in equipment damage and/or personal injury.

Components

	A	B	C	D
1				<p>M6 x 14mm</p>
2				
3				
4		<p>5mm</p>	<p>2.5 mm</p>	<p>4 mm</p>

Tools Needed

Optional for Pan Adjustment

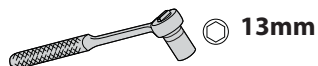

205 Westwood Ave, Long Branch, NJ 07740
 Phone: 866-94 BOARDS (26273) / (732)-222-1511
 Fax: (732)-222-7088 | E-mail: sales@touchboards.com

Set-up Steps



Warning: Because mounting surface materials can vary widely, it is imperative that you make sure mounting surface is strong enough to handle mounted product and equipment.

1

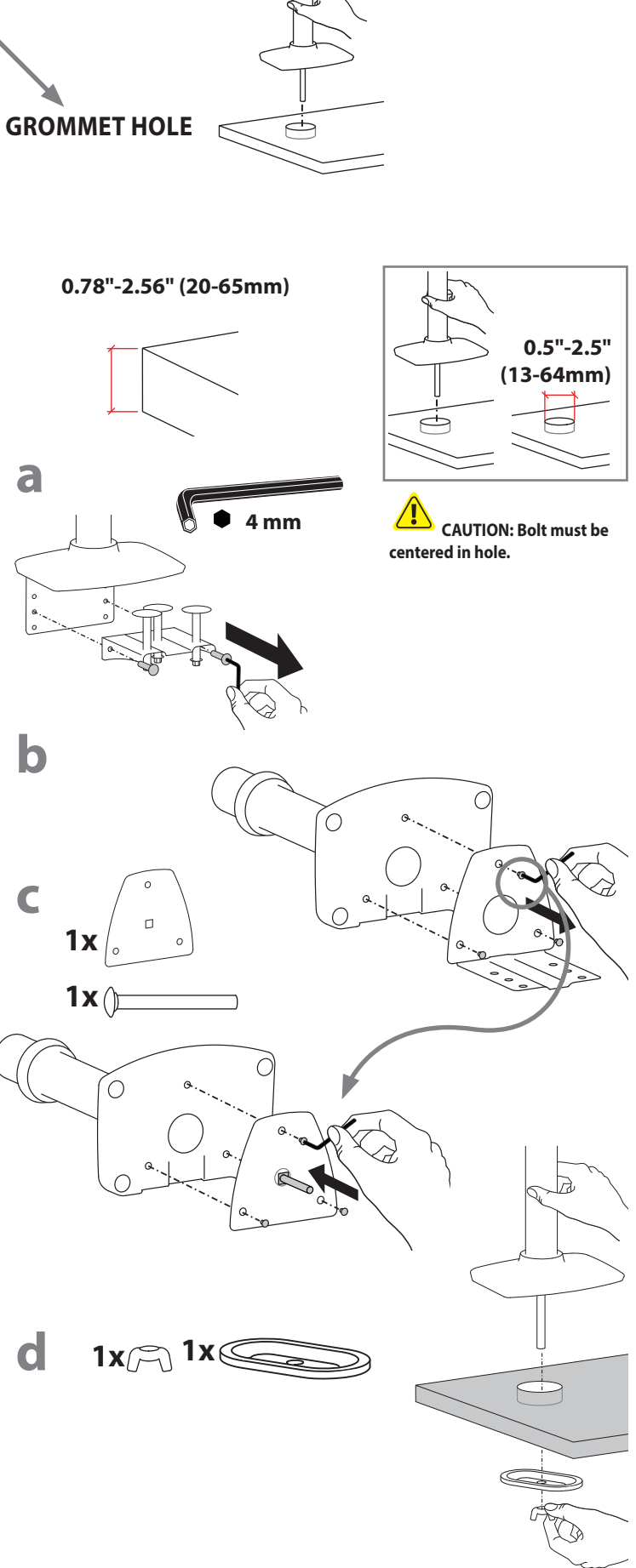
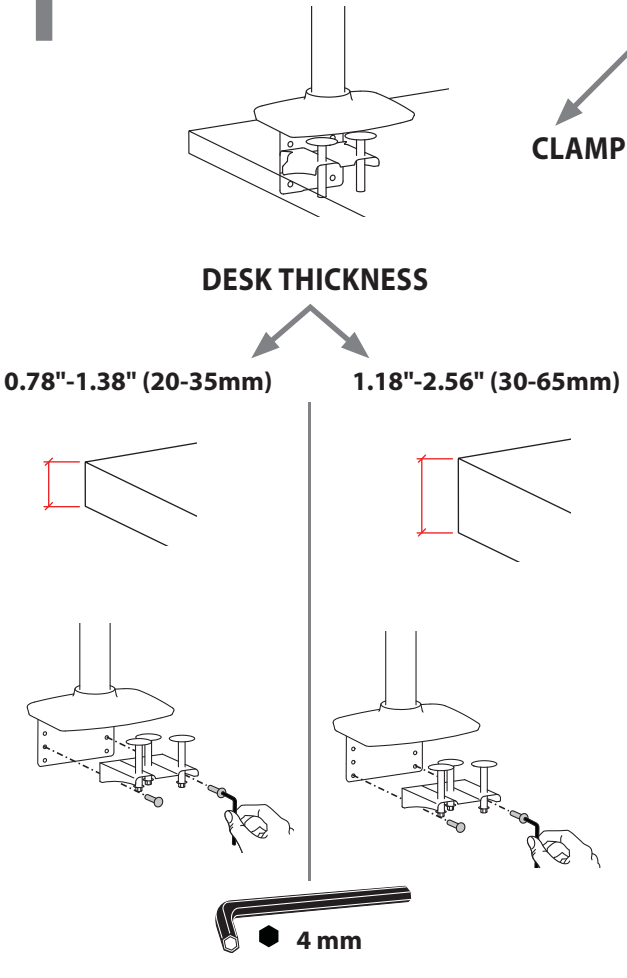

ENGLISH

Set-up Steps

2

1x



The height of the Arms Stop can be moved up or down on pole. If you would like to move the Arm Stop, see page 8 for instructions.

! WARNING: Arm must be removed from pole before moving Arm Stop. Failure to remove arm may result in equipment damage and/or personal injury.

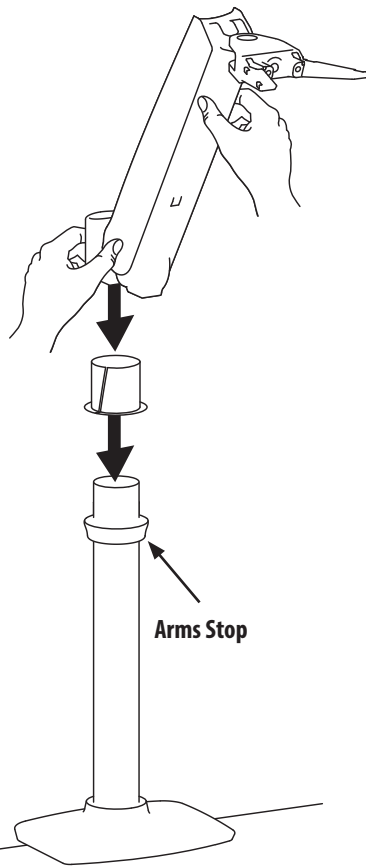

Warning! Do not move arm until Lock is installed in the next step. Failure to follow these instructions may result in your arm coming off the pole base and causing equipment damage and/or personal injury.



Warning! When removing arm from desk, remove arm from pole base before removing clamp or grommet hole mount from desk. Failure to follow these instructions may result in the arm falling over causing equipment damage and/or personal injury.

3

1x



1x



4 mm

a

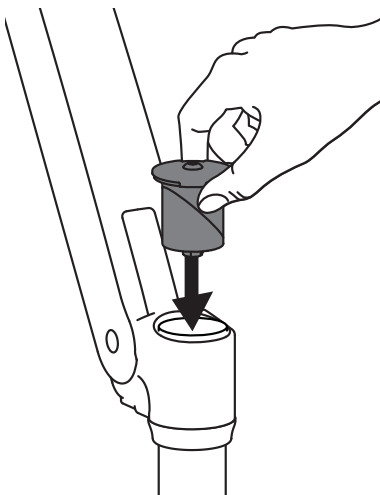

b

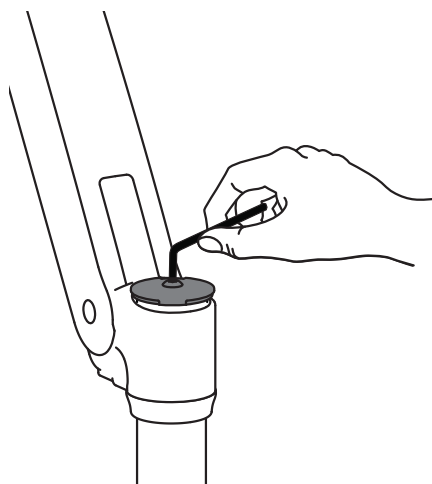

c

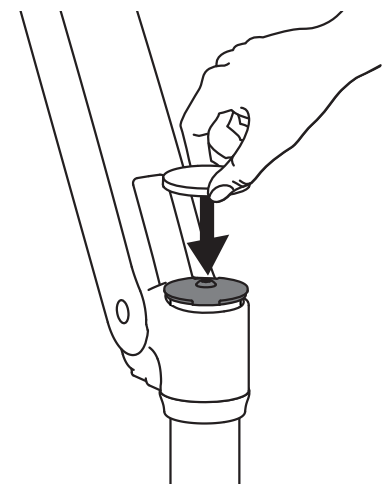

4

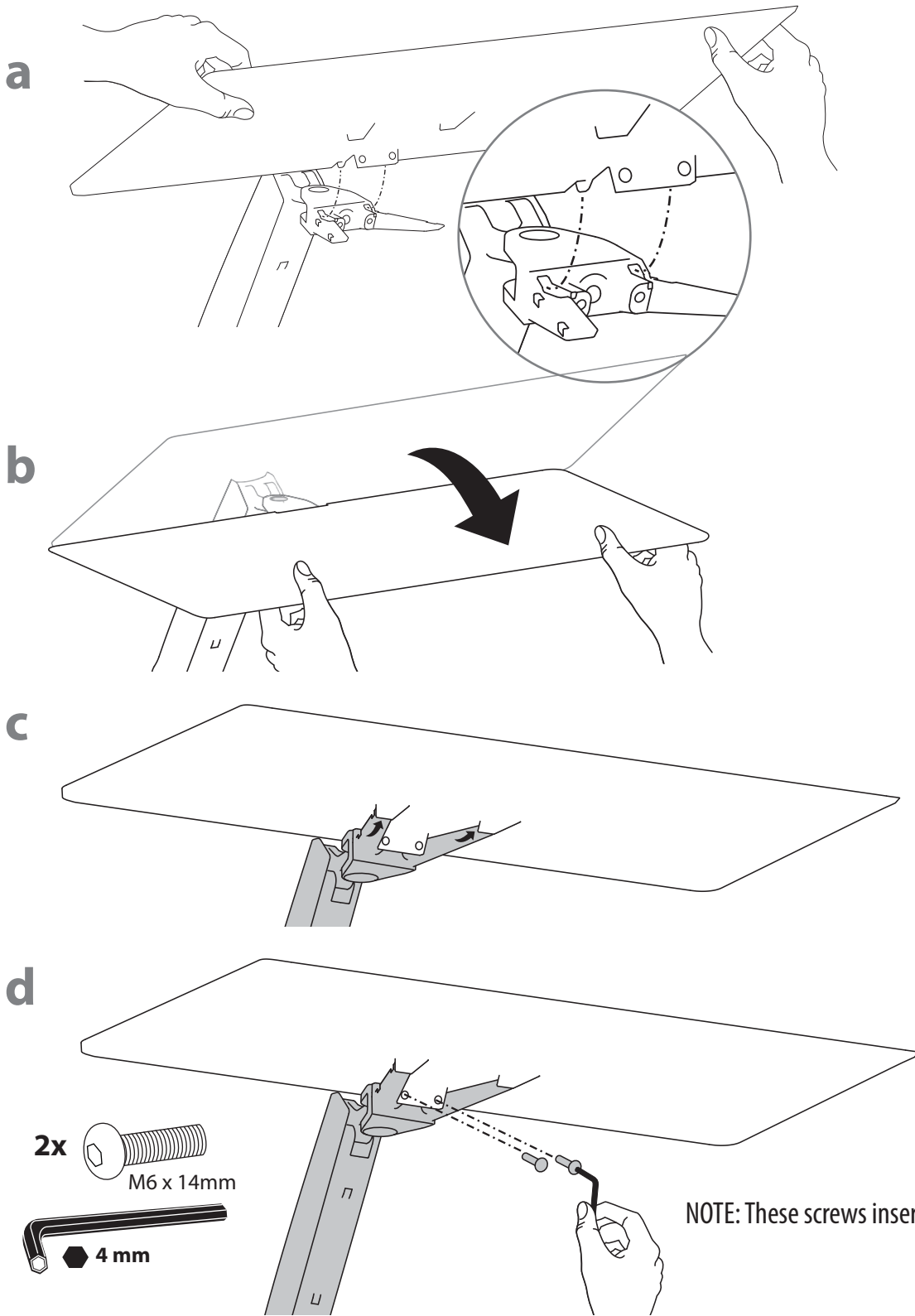

5

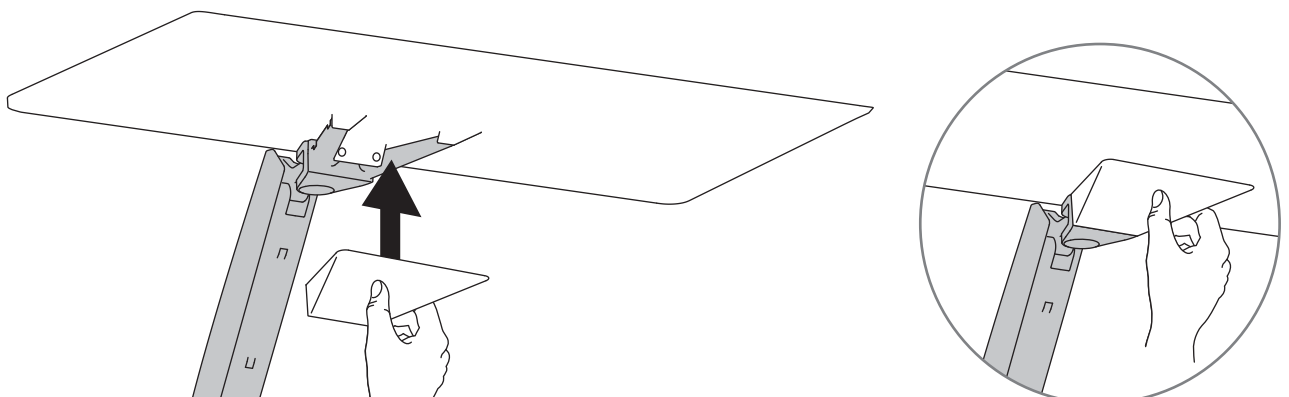

6 Adjustment Step

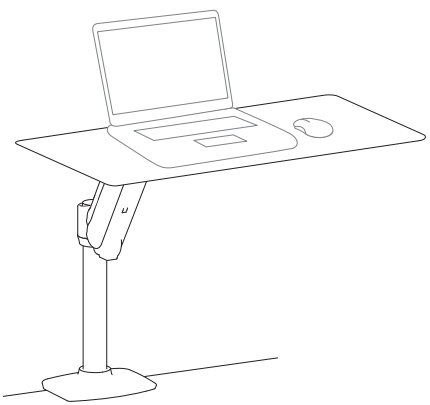

Important! You will need to adjust this product after installation is complete. Make sure all your equipment is properly installed on the product before attempting adjustments. This product should move smoothly and easily through the full range of motion and stay where you set it. If movements are too easy or difficult or if product does not stay in desired positions, follow the adjustment instructions to create smooth and easy movements. Depending on your product and the adjustment, it may take many turns to notice a difference. Any time equipment is added or removed from this product, resulting in a change in the weight of the mounted load, you should repeat these adjustment steps to ensure safe and optimum operation.

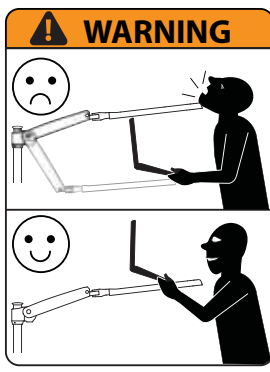
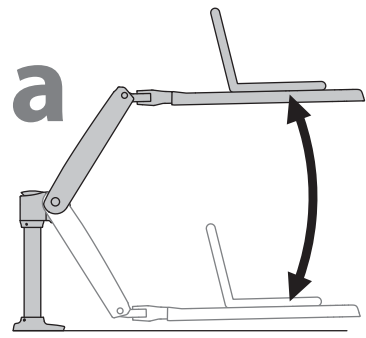

WARNING! Stored Energy Hazard: The arm mechanism is under tension and will move up rapidly, on its own, as soon as attached equipment is removed. For this reason, **DO NOT** remove equipment unless the arm has been moved to the highest position! Failure to follow this instruction may result in serious personal injury and/or equipment damage!

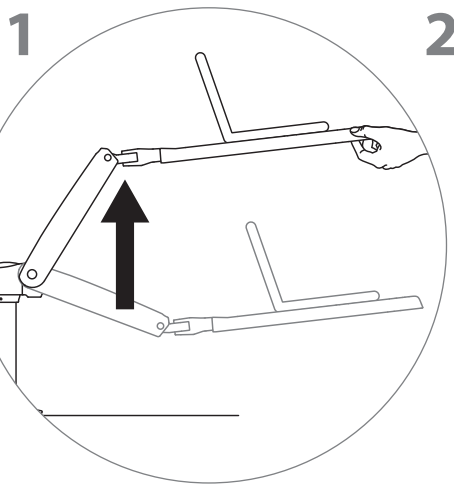

Increase Lift Strength
If the mounted weight is too heavy or this product does not stay up when raised, then you'll need to increase Lift Strength:



Decrease Lift Strength
If the mounted weight is too light or this product does not stay down when lowered, then you'll need to decrease Lift Strength:



Adjustment Step

b

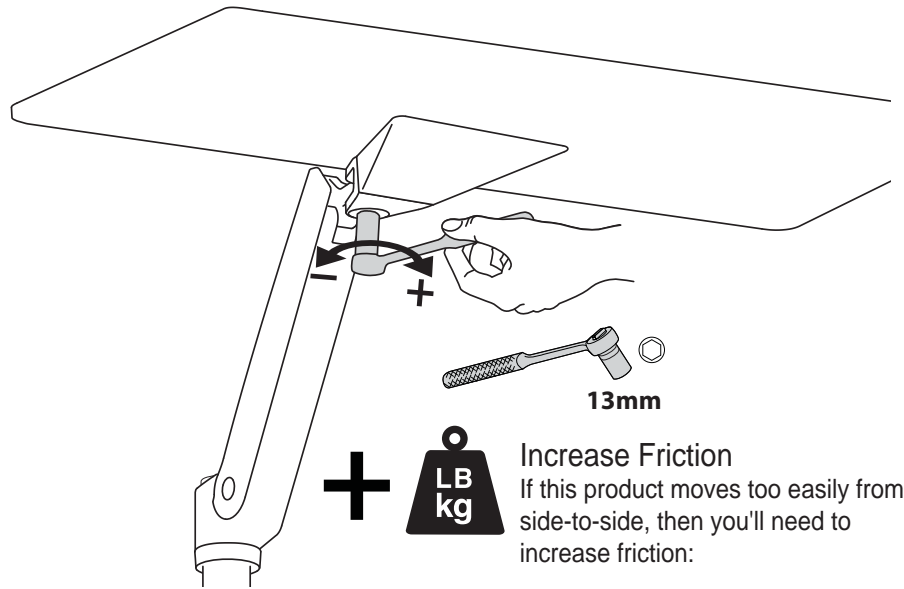
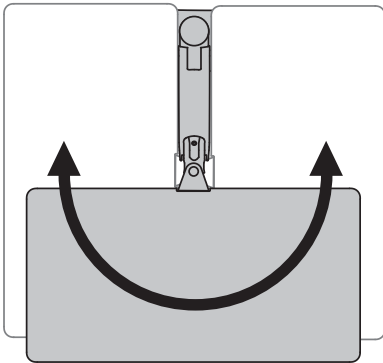

13mm



Increase Friction

If this product moves too easily from side-to-side, then you'll need to increase friction:



Decrease Friction

If this product is too difficult to move from side-to-side, then you'll need to decrease friction:

ENGLISH

C The height of the Arms Stop can be moved up or down on pole.



WARNING: Arm must be removed from pole before moving Arm Stop. Failure to remove arm may result in equipment damage and/or personal injury.

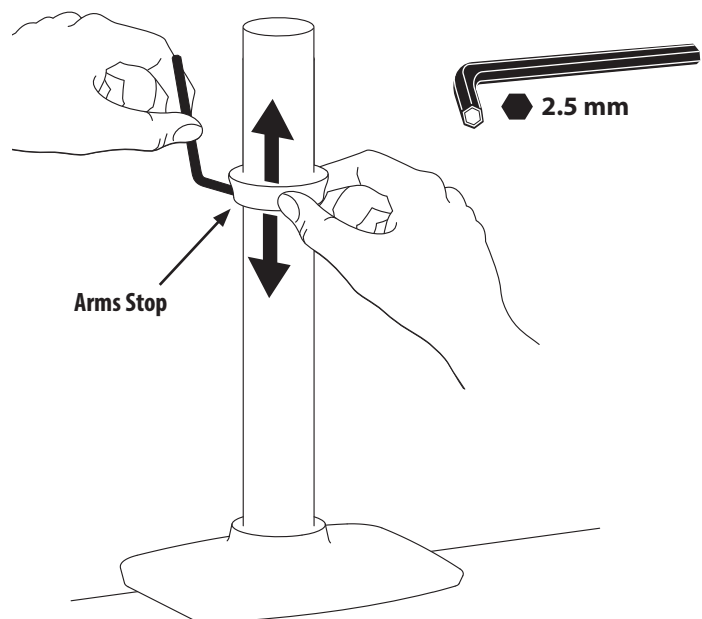
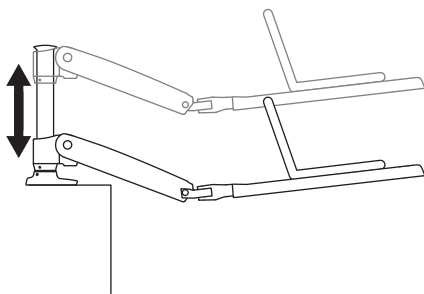

2.5 mm

Features & Specifications

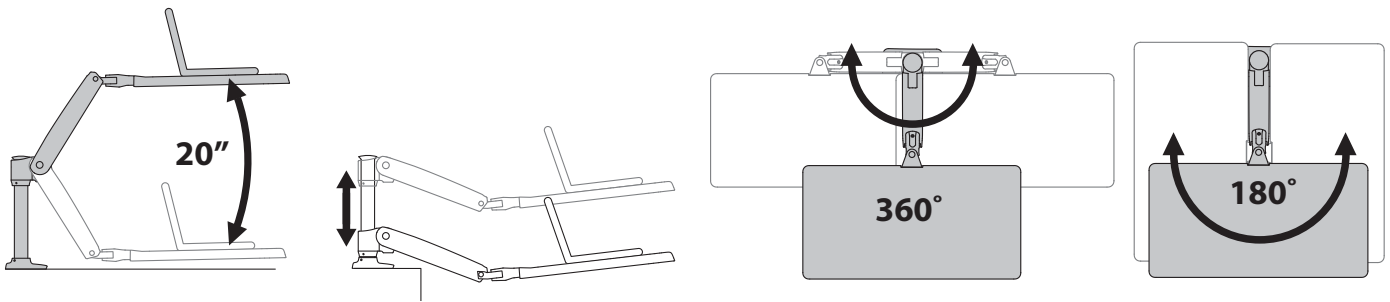

Set Your Workstation to Work For YOU!

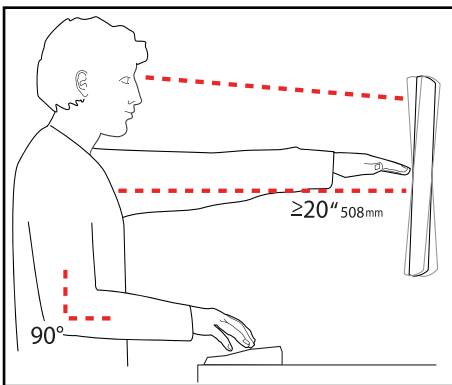

Learn more about ergonomic computer use at:
www.computingcomfort.org

- Height** Position top of screen slightly below eye level.
Position keyboard at about elbow height with wrists flat.
- Distance** Position screen an arm's length from face—at least 20" (508mm).
Position keyboard close enough to create a 90° angle in elbow.
- Angle** Tilt screen to eliminate glare.
Tilt the keyboard back 10° so that your wrists remain flat.

- To Reduce Fatigue**
 Breathe - Breathe deeply through your nose.
 Blink - Blink often to avoid dry eyes.
 Break • 2 to 3 minutes every 20 minutes
 • 15 to 20 minutes every 2 hours.

ENGLISH

For service and warranty visit www.ergotron.com



NOTE: When contacting customer service, reference the serial number.

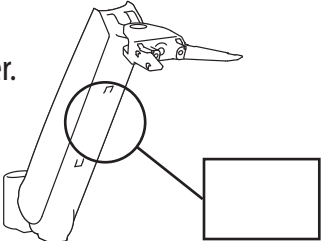

Touchboards

205 Westwood Ave, Long Branch, NJ 07740
 Phone: 866-94 BOARDS (26273) / (732)-222-1511
 Fax: (732)-222-7088 | E-mail: sales@touchboards.com



© 2013 Ergotron, Inc.
 All rights reserved.

While Ergotron, Inc. makes every effort to provide accurate and complete information on the installation and use of its products, it will not be held liable for any editorial errors or omissions (including those made in the process of translation from English to another language), or for incidental, special or consequential damages of any nature resulting from furnishing this instruction and performance of equipment in connection with this instruction. Ergotron, Inc. reserves the right to make changes in the product design and/or product documentation without notification to its users. For the most current product information, or to know if this document is available in languages other than those herein, please contact Ergotron. No part of this publication may be reproduced, stored in a retrieval system, or transmitted in any form or by any means, electronic, mechanical, photocopying, recording or otherwise without the prior written consent of Ergotron, Inc., 1181 Trapp Road, Eagan, Minnesota, 55121, USA. Patents Pending and Patented U.S. & Foreign. Ergotron is a registered trademark of Ergotron, Inc.

Americas Sales and Corporate Headquarters

St. Paul, MN USA
 (800) 888-8458
 +1-651-681-7600
www.ergotron.com
sales@ergotron.com

EMEA Sales

Amersfoort, The Netherlands
 +31 33 45 45 600
www.ergotron.com
info.eu@ergotron.com

APAC Sales

Tokyo, Japan
www.ergotron.com
apaccustomerservice@ergotron.com

Worldwide OEM Sales

www.ergotron.com
info.oem@ergotron.com