

HX Desk Dual Monitor Arm

with C-Clamp (top mount)



Weight Capacity per monitor:
5 lbs. - 17.5 lbs.
(2.3 kg - 7.9 kg)

Range of Motion

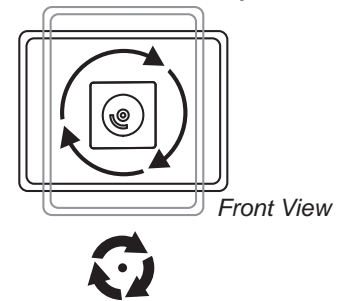
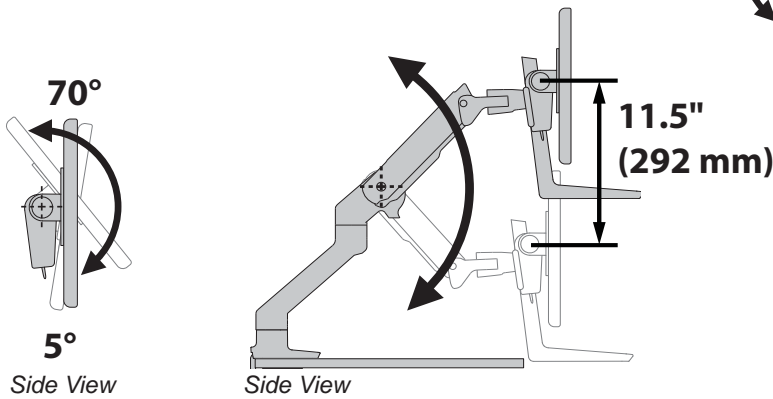
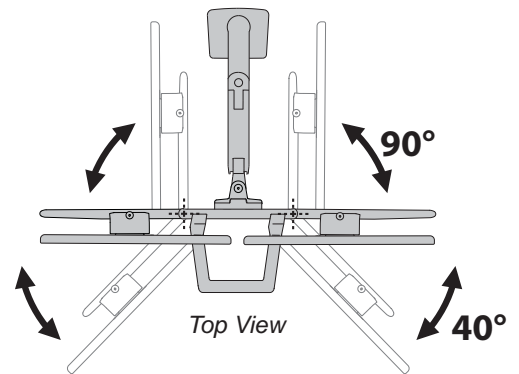
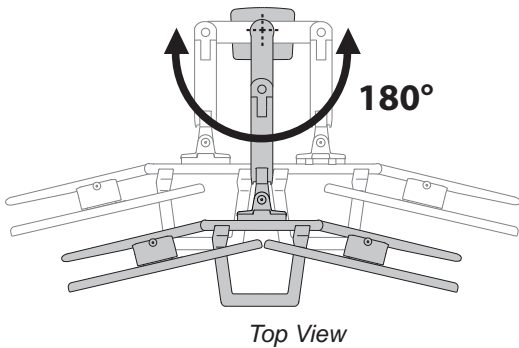
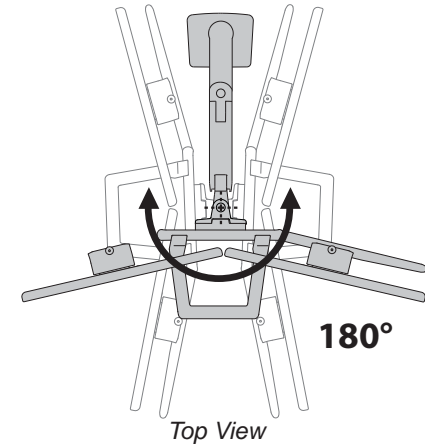
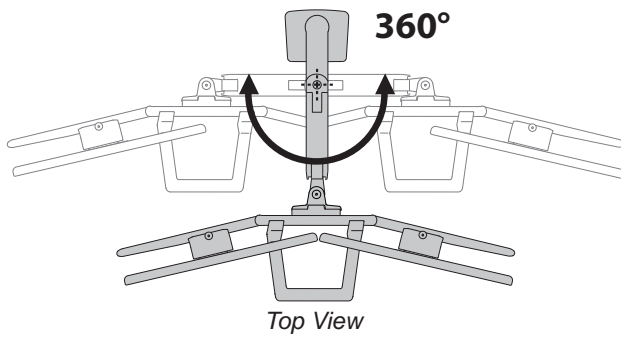

Portrait/Landscape Rotation

© 2017 Ergotron, Inc. rev. 05/08/2017 DIM-HXTopCclamp Content is subject to change without notification

Americas Sales and Corporate Headquarters

St. Paul, MN USA
(800) 888-8458
+1-651-681-7600
www.ergotron.com
sales@ergotron.com

EMEA Sales

Amersfoort, The Netherlands
+31 33 45 45 600
www.ergotron.com
info.eu@ergotron.com

APAC Sales

Tokyo, Japan
www.ergotron.com
apaccustomerservice@ergotron.com

Worldwide OEM Sales

www.ergotron.com
info.oem@ergotron.com

ERGOTRON®

HX Desk Dual Monitor Arm

with C-Clamp (top mount)

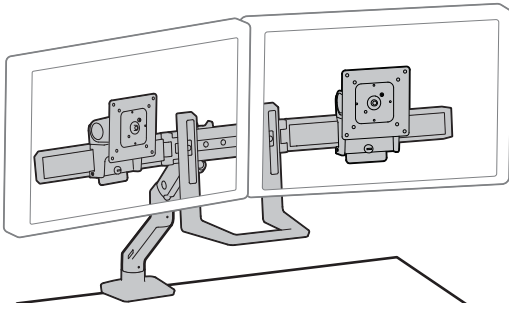

Dimensions

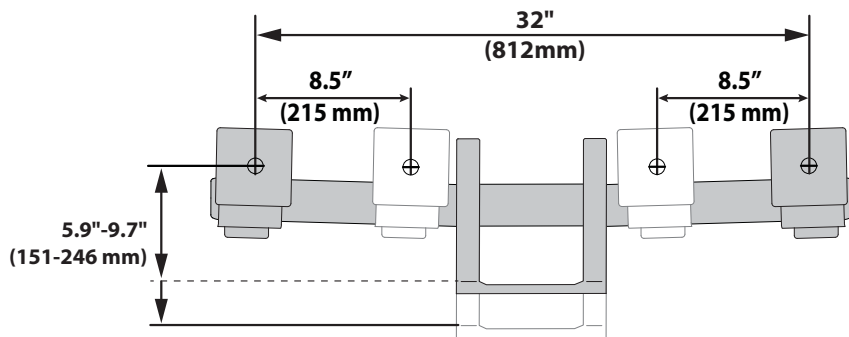
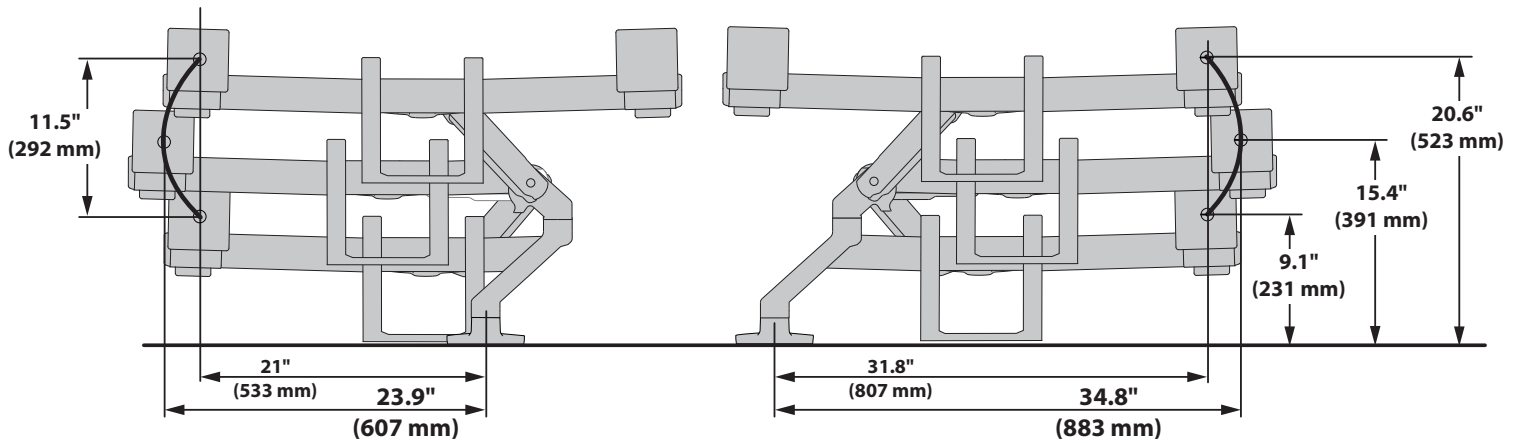

Max Monitor Size

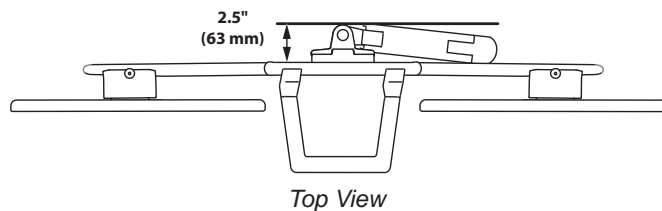
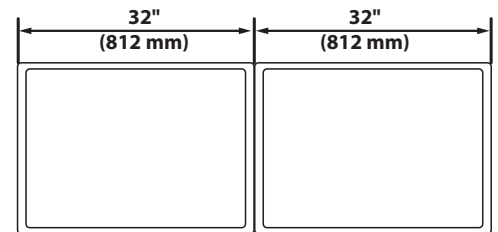

© 2017 Ergotron, Inc. rev. 05/08/2017 DIM-HXTopCclamp Content is subject to change without notification

Americas Sales and Corporate Headquarters

St. Paul, MN USA
(800) 888-8458
+1-651-681-7600
www.ergotron.com
sales@ergotron.com

EMEA Sales

Amersfoort, The Netherlands
+31 33 45 45 600
www.ergotron.com
info.eu@ergotron.com

APAC Sales

Tokyo, Japan
www.ergotron.com
apaccustomerservice@ergotron.com

Worldwide OEM Sales

www.ergotron.com
info.oem@ergotron.com

ERGOTRON®

HX Desk Dual Monitor Arm with C-Clamp (top mount)

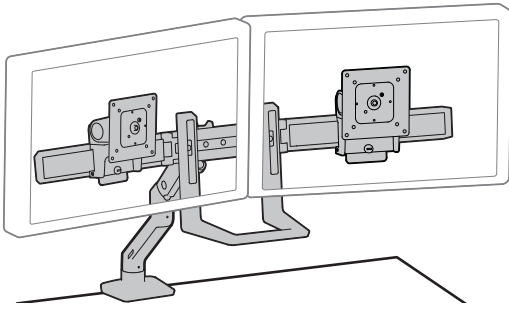

Dimensions

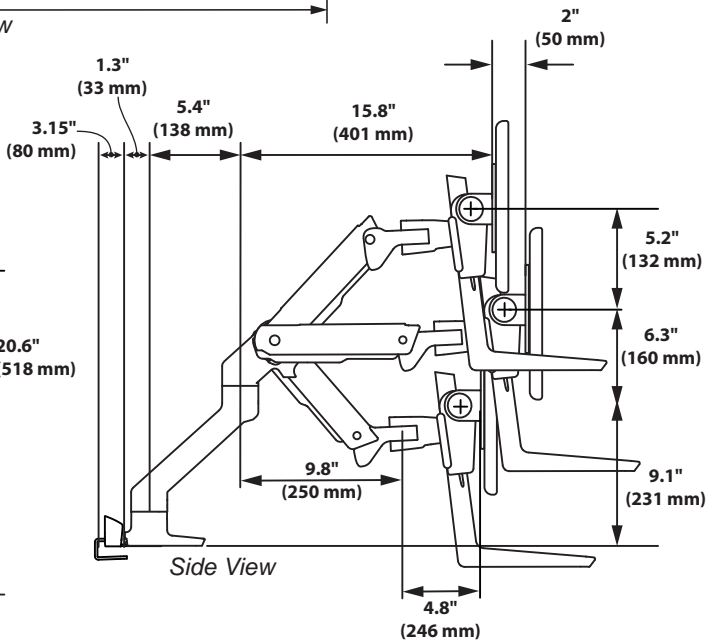
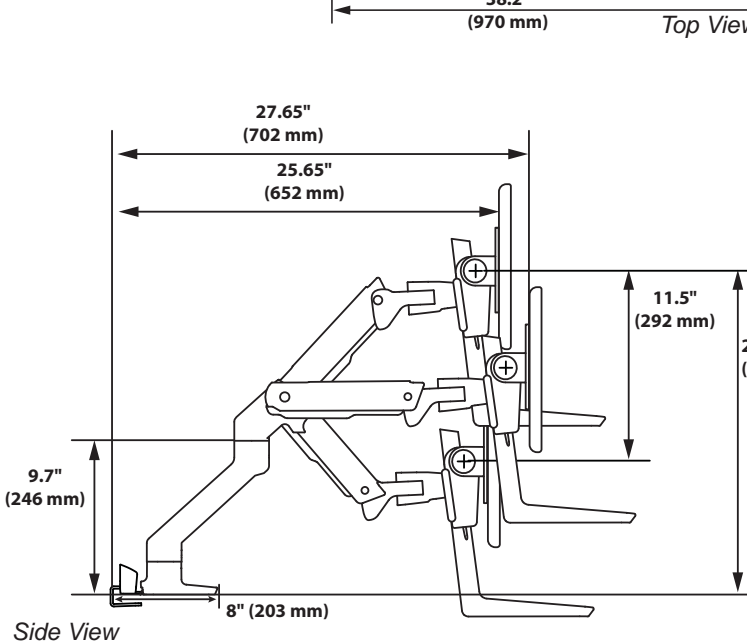
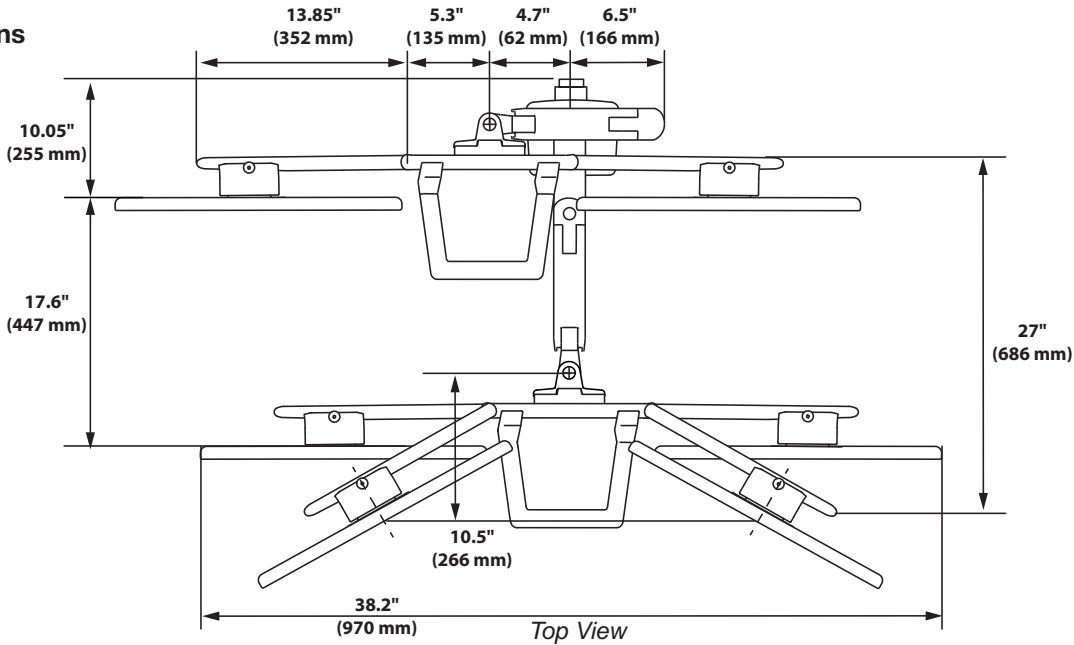

© 2017 Ergotron, Inc. rev. 05/08/2017 DIM-HXTopCclamp Content is subject to change without notification

Americas Sales and Corporate Headquarters

St. Paul, MN USA
(800) 888-8458
+1-651-681-7600
www.ergotron.com
sales@ergotron.com

EMEA Sales

Amersfoort, The Netherlands
+31 33 45 45 600
www.ergotron.com
info.eu@ergotron.com

APAC Sales

Tokyo, Japan
www.ergotron.com
apaccustomerservice@ergotron.com

Worldwide OEM Sales

www.ergotron.com
info.oem@ergotron.com



HX Desk Dual Monitor Arm

with C-Clamp (top mount)

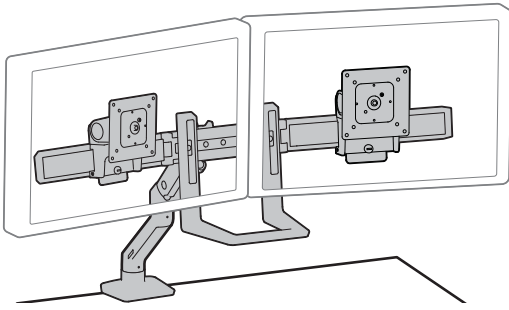

Dimensions

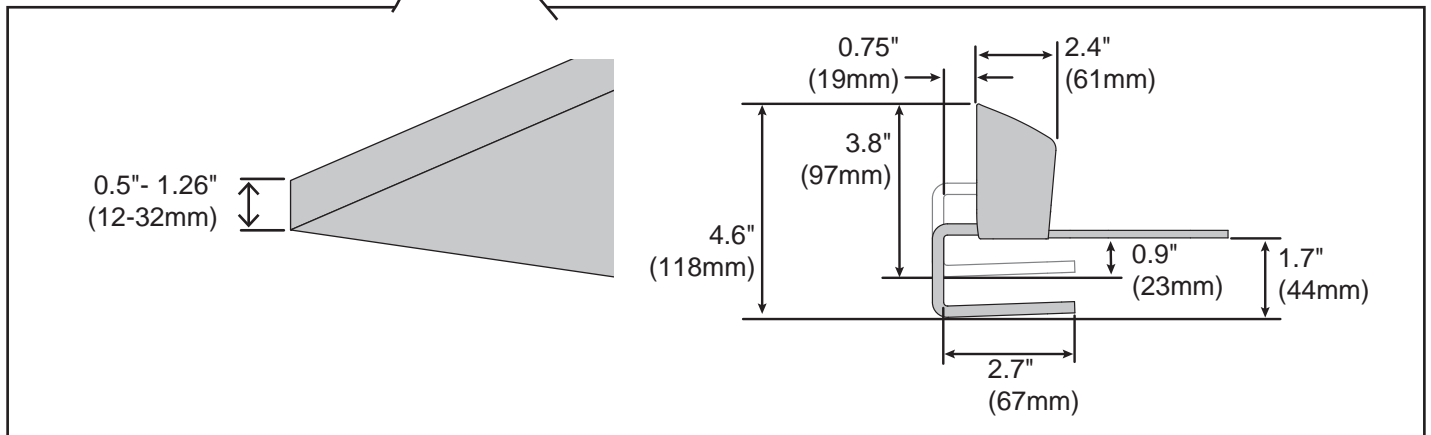
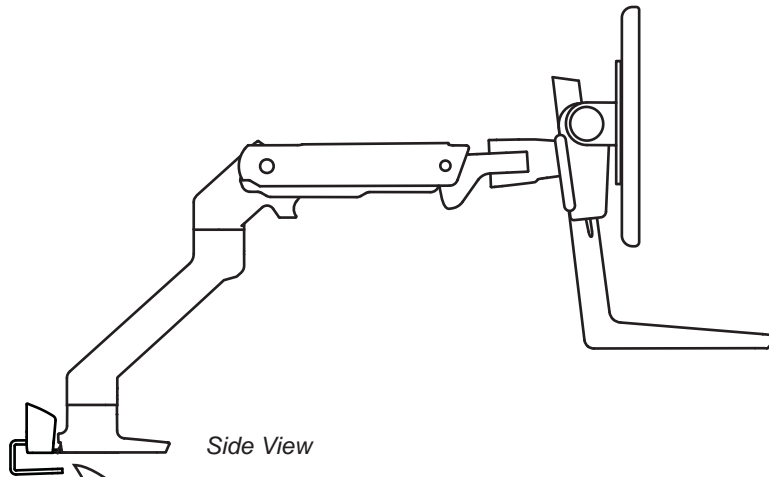

© 2017 Ergotron, Inc. rev. 05/08/2017 DIM-HXTopCclamp **Content is subject to change without notification**

Americas Sales and Corporate Headquarters

St. Paul, MN USA
 (800) 888-8458
 +1-651-681-7600
 www.ergotron.com
 sales@ergotron.com

EMEA Sales

Amersfoort, The Netherlands
 +31 33 45 45 600
 www.ergotron.com
 info.eu@ergotron.com

APAC Sales

Tokyo, Japan
 www.ergotron.com
 apaccustomerservice@ergotron.com

Worldwide OEM Sales

www.ergotron.com
 info.oem@ergotron.com

