

[www.ergotron.com](http://www.ergotron.com)

USA 1-800-888-8458

Europe +31 (0)33-45 45 600

China 86-769-86018920

For service and warranty visit [www.ergotron.com](http://www.ergotron.com)  
 Si desea información de servicio y garantía, visite [www.ergotron.com](http://www.ergotron.com)  
 Pour toute question concernant la garantie ou le service client, consultez [www.ergotron.com](http://www.ergotron.com)  
 Weitere Informationen zu Service und Gewährleistung erhalten Sie unter [www.ergotron.com](http://www.ergotron.com).  
 Ga voor service en garantie naar [www.ergotron.com](http://www.ergotron.com)  
 Per assistenza e la garanzia visitate [www.ergotron.com](http://www.ergotron.com)  
 Gå in på [www.ergotron.com](http://www.ergotron.com) för service och garanti  
 サービスおよび保証については、[www.ergotron.com](http://www.ergotron.com) をご覧ください。  
 有关服务和保修，请访问 [www.ergotron.com](http://www.ergotron.com)

**ASSEMBLY INSTRUCTIONS**  
**Instrucciones de instalación**  
**Notice d'assemblage**  
**Montageanleitungen**  
**Installatie instructies**  
**Manuali d'Istruzione**  
 取扱説明書  
 安装说明

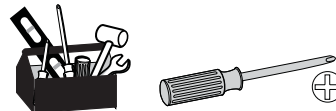
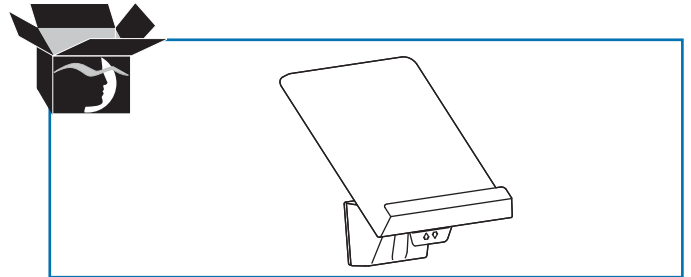
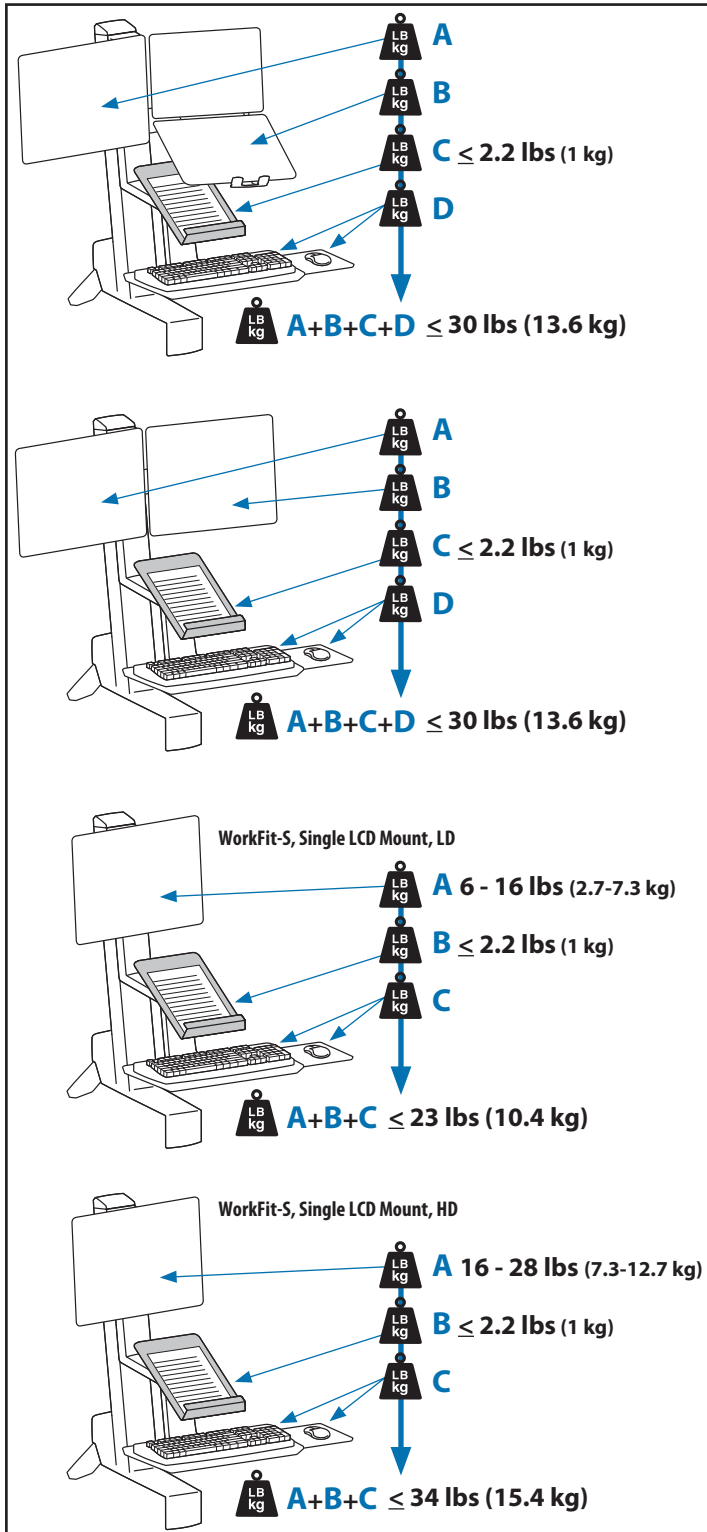

# Touchboards

205 Westwood Ave, Long Branch, NJ 07740  
 Phone: 866-94 BOARDS (26273) / (732)-222-1511  
 Fax: (732)-222-7088 | E-mail: [sales@touchboards.com](mailto:sales@touchboards.com)

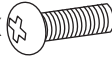
**1** 4x  M4 x 16mm

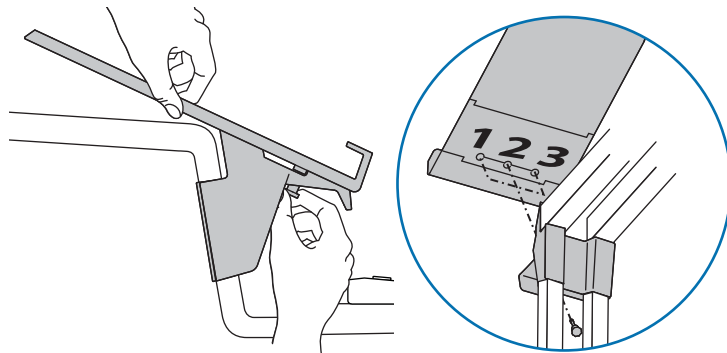
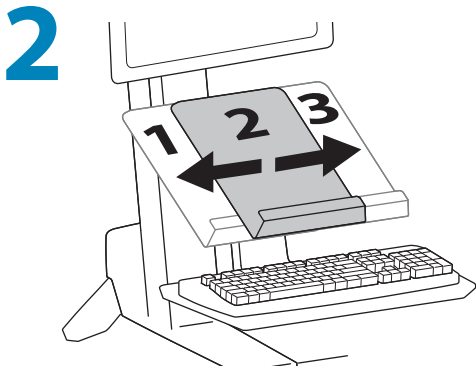
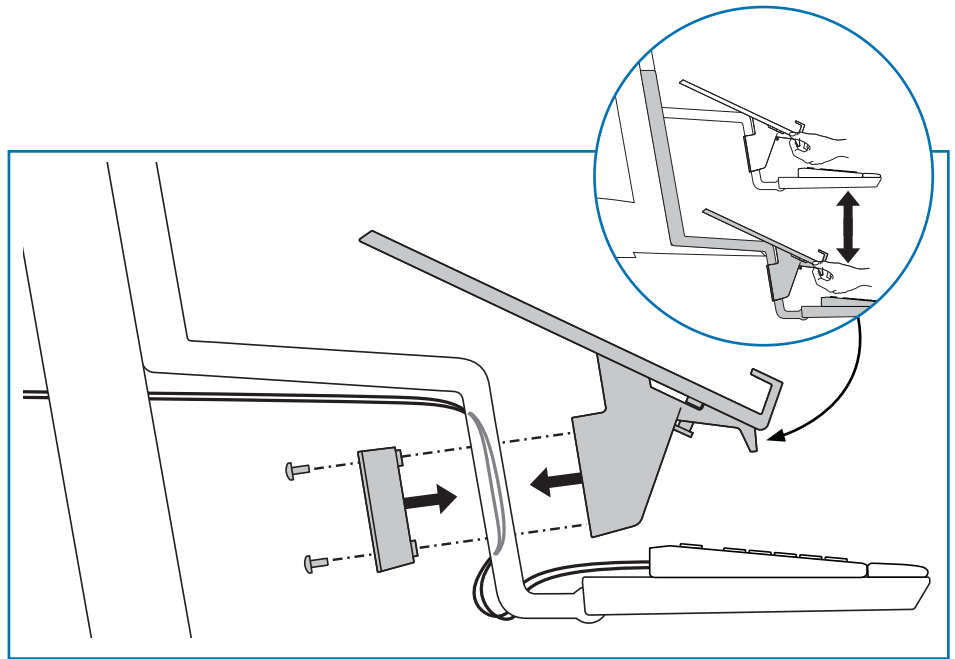
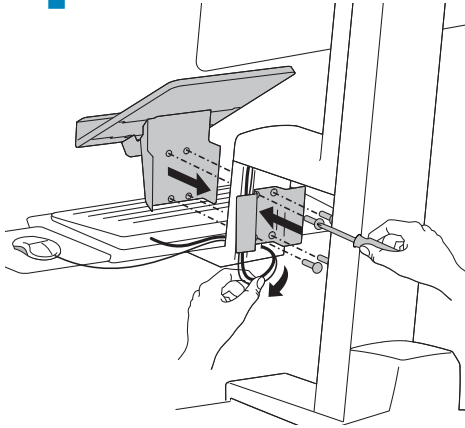

# Touchboards

205 Westwood Ave, Long Branch, NJ 07740  
 Phone: 866-94 BOARDS (26273) / (732)-222-1511  
 Fax: (732)-222-7088 | E-mail: [sales@touchboards.com](mailto:sales@touchboards.com)



© 2011 Ergotron, Inc.  
 All rights reserved.

While Ergotron, Inc. makes every effort to provide accurate and complete information on the installation and use of its products, it will not be held liable for any editorial errors or omissions (including those made in the process of translation from English to another language), or for incidental, special or consequential damages of any nature resulting from furnishing this instruction and performance of equipment in connection with this instruction. Ergotron, Inc. reserves the right to make changes in the product design and/or product documentation without notification to its users. For the most current product information, or to know if this document is available in languages other than those herein, please contact Ergotron. No part of this publication may be reproduced, stored in a retrieval system, or transmitted in any form or by any means, electronic, mechanical, photocopying, recording or otherwise without the prior written consent of Ergotron, Inc., 1181 Trapp Road, Eagan, Minnesota, 55121, USA. Patents Pending and Patented U.S. & Foreign. Ergotron is a registered trademark of Ergotron, Inc.

**Americas Sales and Corporate Headquarters**

St. Paul, MN USA  
 (800) 888-8458  
 +1-651-681-7600  
[www.ergotron.com](http://www.ergotron.com)  
[sales@ergotron.com](mailto:sales@ergotron.com)

**EMEA Sales**

Amersfoort, The Netherlands  
 +31 33 45 45 600  
[www.ergotron.com](http://www.ergotron.com)  
[info.eu@ergotron.com](mailto:info.eu@ergotron.com)

**APAC Sales**

Tokyo, Japan  
[www.ergotron.com](http://www.ergotron.com)  
[apacustomerservice@ergotron.com](mailto:apacustomerservice@ergotron.com)

**Worldwide OEM Sales**

[www.ergotron.com](http://www.ergotron.com)  
[info.oem@ergotron.com](mailto:info.oem@ergotron.com)