

Touchboards

205 Westwood Ave, Long Branch, NJ 07740
 Phone: 866-94 BOARDS (26273) / (732)-222-1511
 Fax: (732)-222-7088 | E-mail: sales@touchboards.com

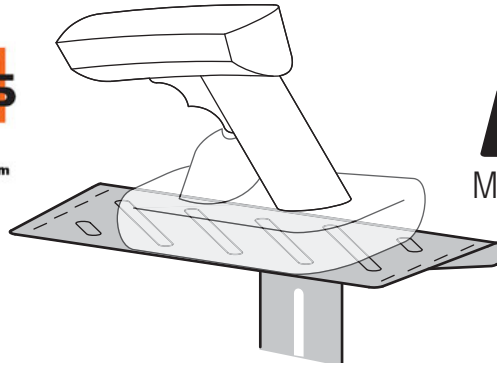

Max weight: 2 lbs (1 kg)

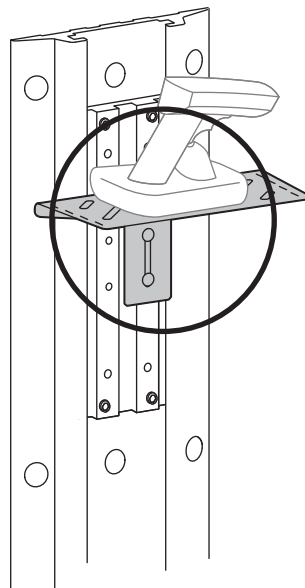
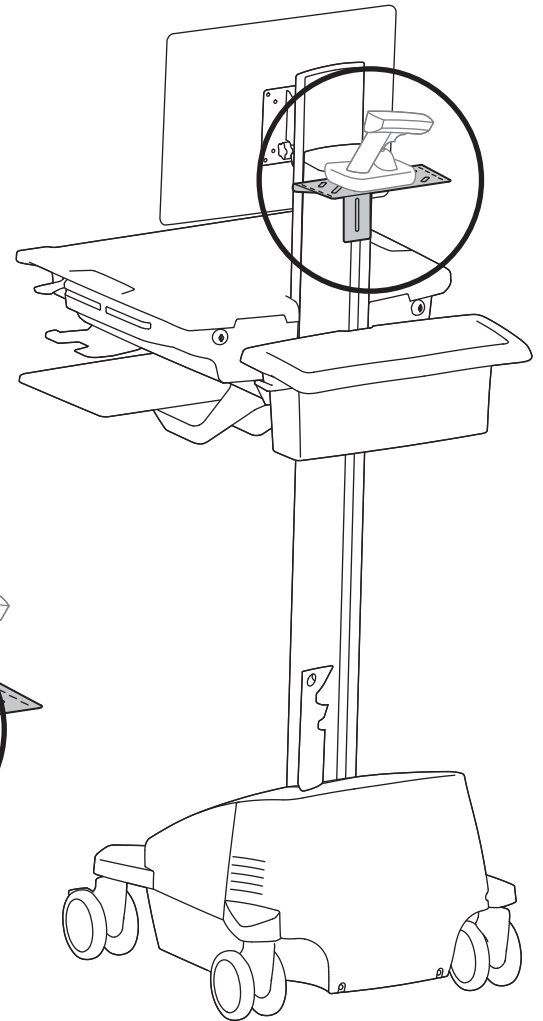
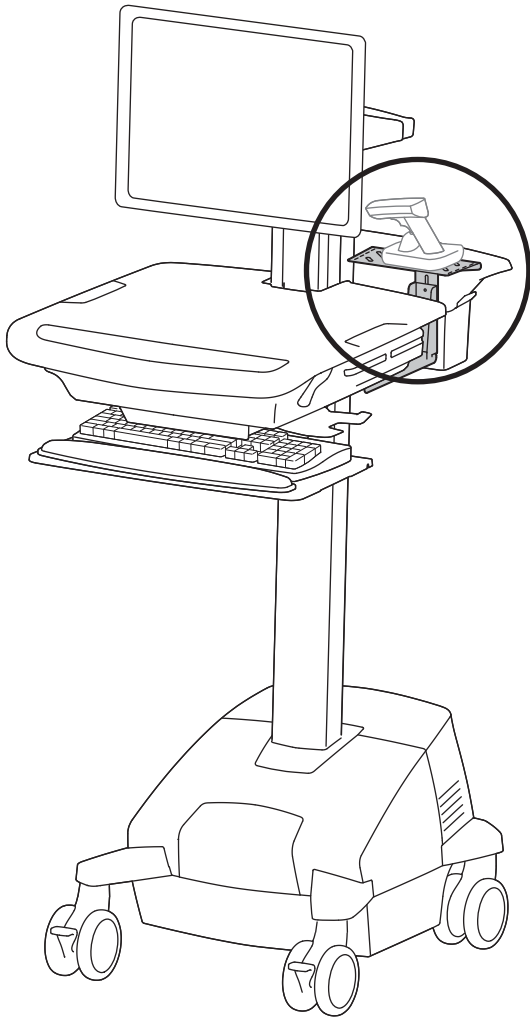

SV Cart & Head Unit

- Option 1 - LCD Carts
- Option 2 - Laptop Carts
- Option 3 - Wall Track

- Option 4 - Back of SV Cart







 www.ergotron.com
 USA 1-800-888-8458
 Europe +31 (0)33-45 45 600
 China 400-120-3051

For service and warranty visit www.ergotron.com/warranty







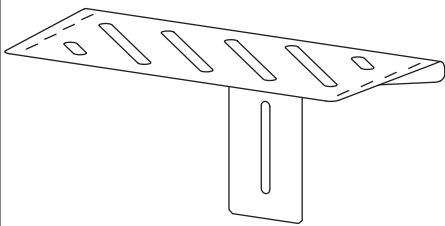
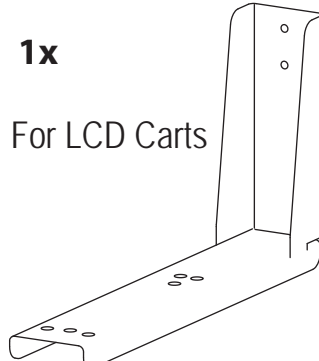
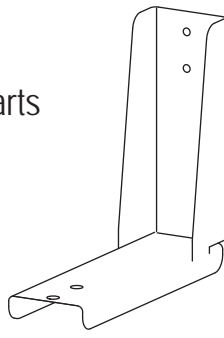

Hazard Symbols Review

These symbols alert users of a safety condition that demands attention. All users should be able to recognize and understand the significance of the following Safety Hazards if encountered on the product or within the documentation. Children who are not able to recognize and respond appropriately to Safety Alerts should not use this product without adult supervision!

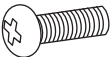
Symbol	Signal Word	Level of Hazard
	NOTE	A NOTE indicates important information that helps you make better use of this product.
	CAUTION	A CAUTION indicates either potential damage to hardware or loss of data and tells you how to avoid the problem.
	WARNING	A WARNING indicates either potential for property damage, personal injury, or death.
	ELECTRICAL	An Electrical indicates an impending electrical hazard which, if not avoided, may result in personal injury, fire and/or death.

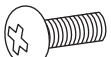
Components

	A	B	C
1	1x 	1x For LCD Carts 	1x For Laptop Carts 
2	1x  1x 	2x  M4 x 16mm	1x 
3	1x 	4x  M5 x 12mm	2x  #8/32x5/16"

Tools Needed

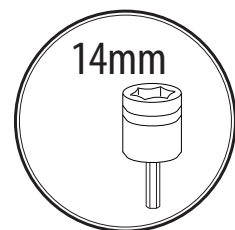
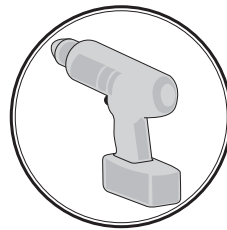
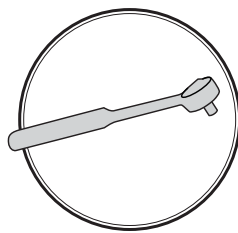
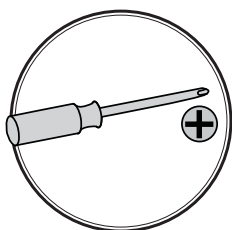
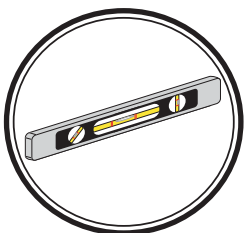

Option 1 - Mounting to right or left side of LCD head unit

CAUTION: Do Not Exceed Maximum SV LCD Cart Weight Capacity 35 lbs. (16 kg). This is the sum of LCD monitor, CPU, keyboard/mouse, scanner and any worksurface load, including drawers, if present. Failure to heed this caution may cause serious Injury or property damage to occur.

1 Open Worksurface with key.

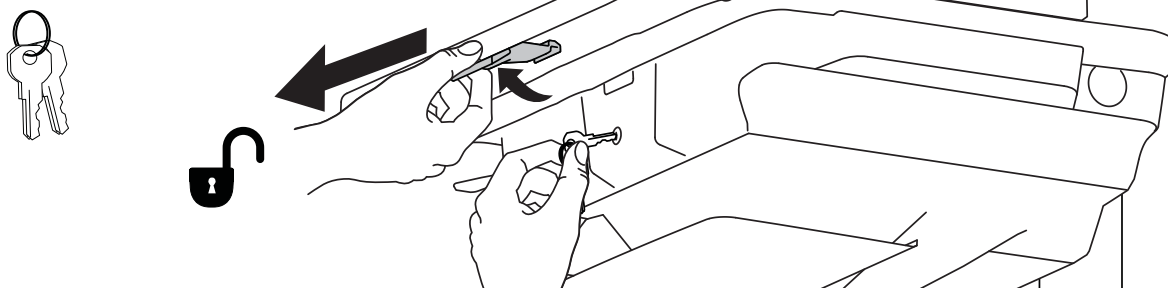

2 a. Attach the shelf bracket to the bottom of the head unit using two M4x16mm Phillips screws.

b. Loosely attach the scanner shelf to the bracket using two M4x8mm Phillips screws. Adjust the shelf to the desired height; ensure that the shelf is level, then tighten the screws.

c. Close and lock worksurface.

d. Go to page 8 for options on how to secure scanner to shelf.

a 2x  M4 x 16mm

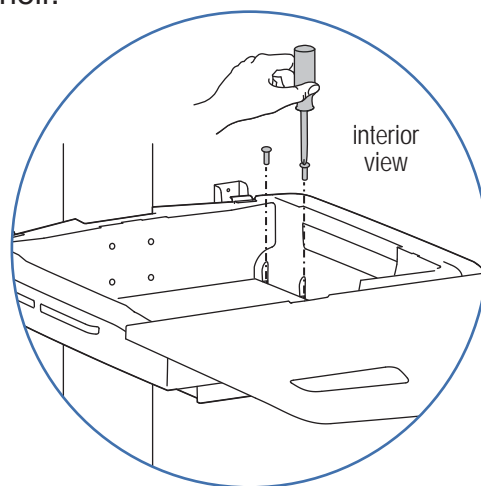
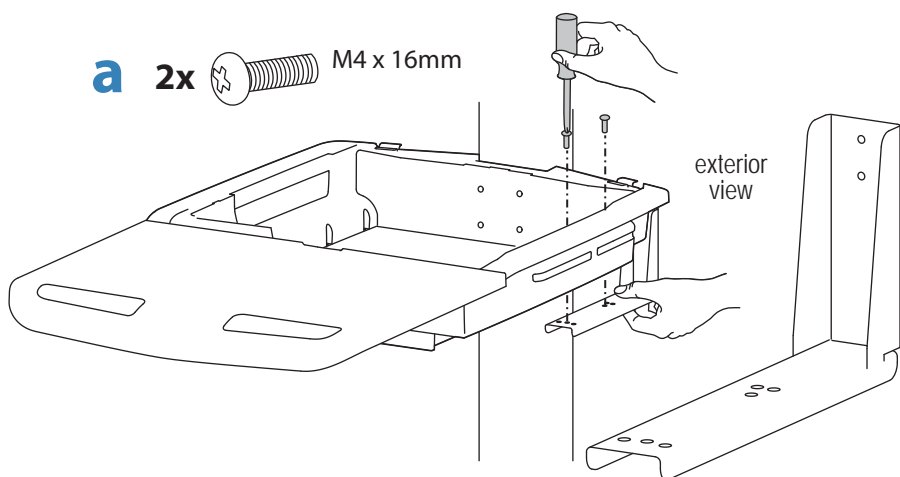

b 2x  M5 x 12mm

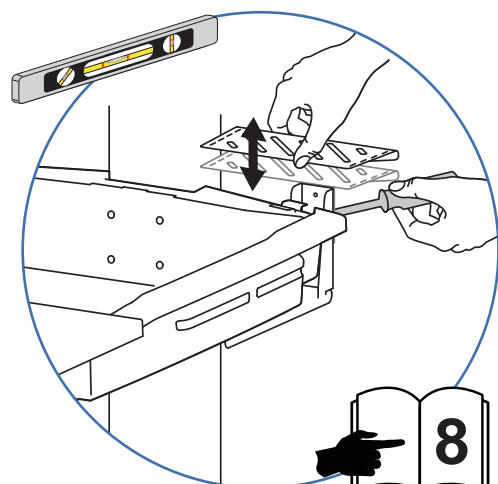
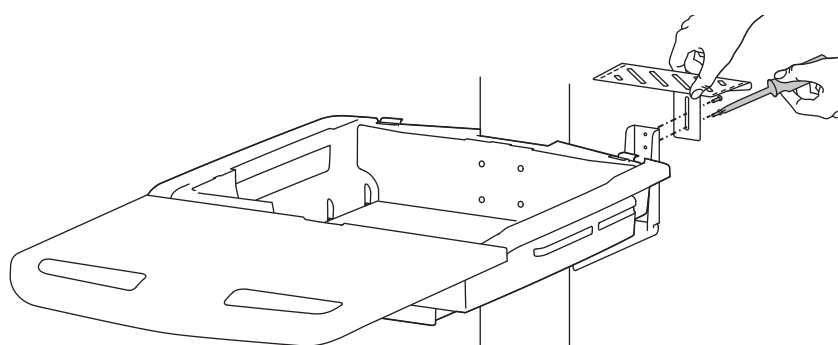

Option 2 - Mounting to right or left side of laptop head unit

CAUTION: Do Not Exceed Maximum SV Laptop Cart Weight Capacity 22 lbs. (10 kg). This is the sum of laptop, keyboard/mouse, scanner and any worksurface load, including drawers, if present. Failure to heed this caution may result in personal injury or property damage.



205 Westwood Ave, Long Branch, NJ 07740
 Phone: 866-94 BOARDS (26273) / (732)-222-1511
 Fax: (732)-222-7088 | E-mail: sales@touchboards.com

- 1 a. Unlock both sides of worksurface.
- b. Remove worksurface.

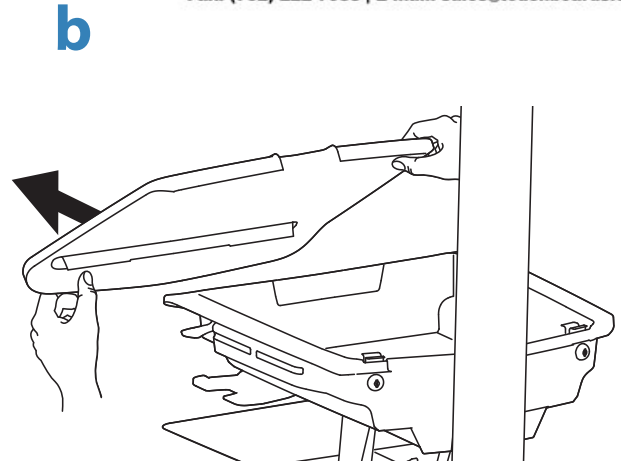
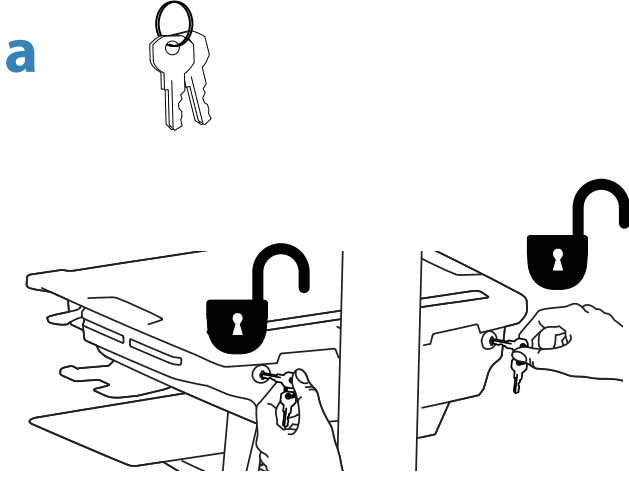

- 2 a. Attach the shelf bracket to the right or left side of the head unit using two M4x16mm Phillips screws.



Note: the screws pass into the head unit floor from above, as illustrated. Laptop support bar may need to be removed temporarily to allow installation of scanner bracket.

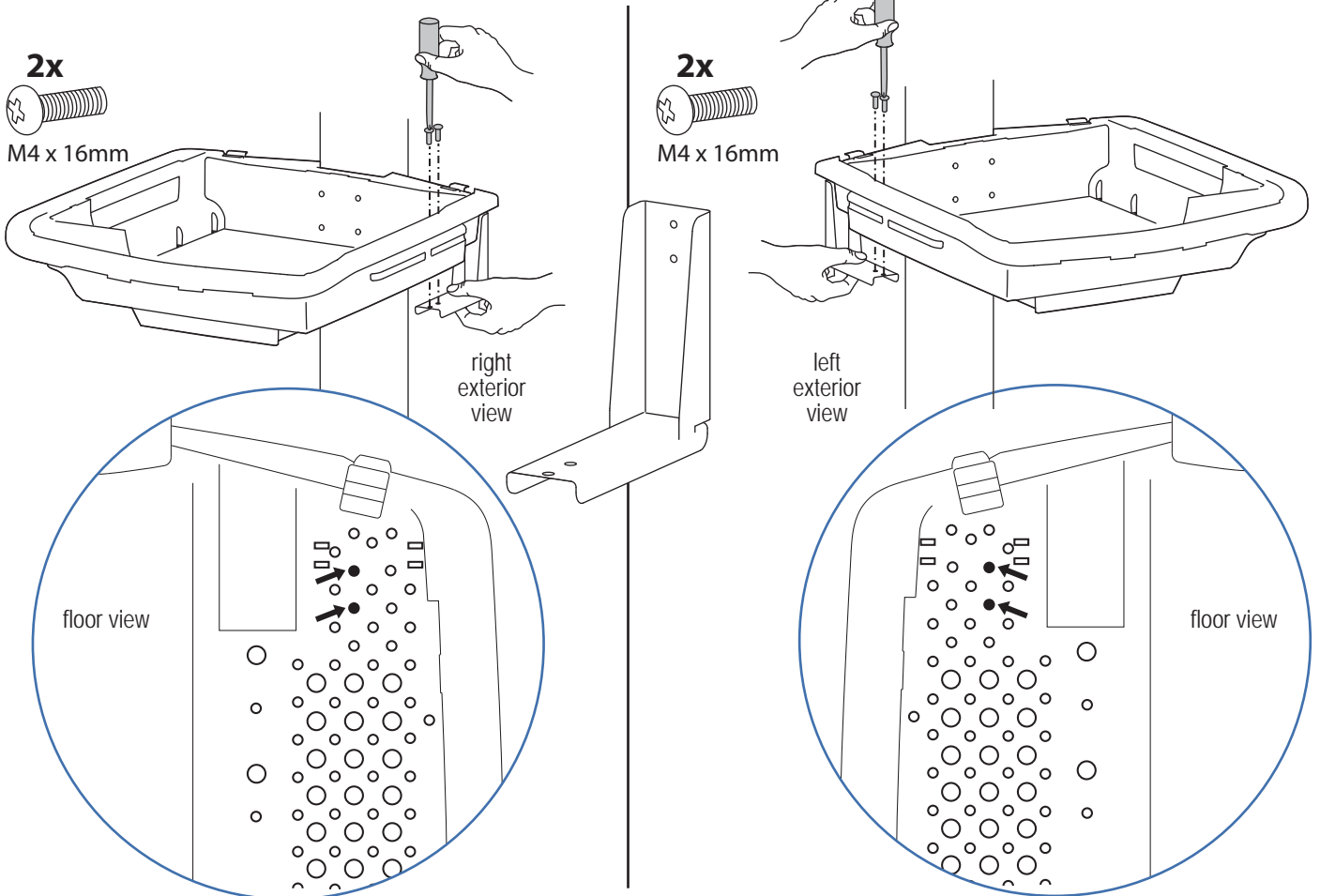

Option 2 - Mounting to right or left side of laptop head unit (cont.)

- 3** a. Loosely attach the scanner shelf to the bracket using two M4x8mm Phillips screws.
- b. Adjust the shelf to the desired height; ensure that the shelf is level, then tighten the screws. Close and lock worksurface.
- c. Go to page 8 for options on how to secure scanner to shelf.
- d. After the scanner has been secured to shelf, follow Step 4 Adjustment, below.

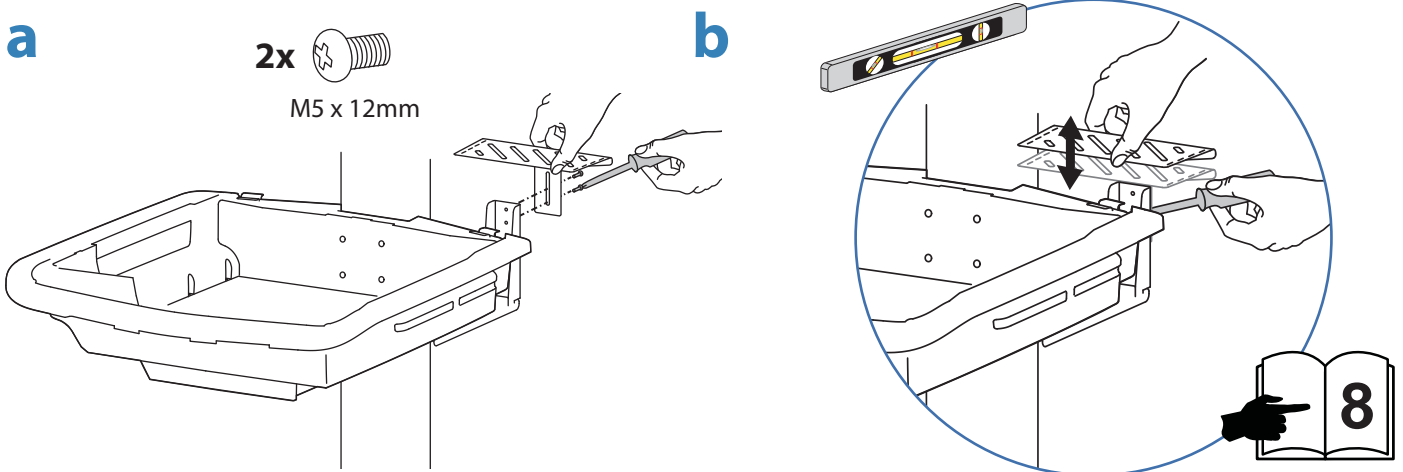

4 Adjustment Step

Lift - Up and down

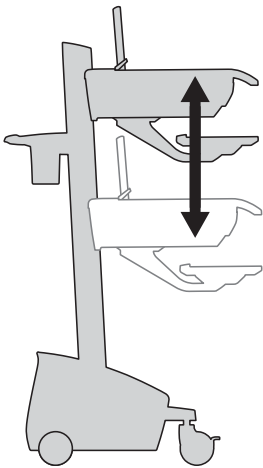

Once the scanner has been mounted to the shelf, it is important that you adjust the lift tension for the additional weight. Test the lift tension by moving the head unit up and down. If it travels smoothly and easily through the full range of motion, and does not drift up or sag down from the place you set it, the tension is good. If not, adjust as directed below:

To change lift tension:

- a. Remove cap and turn adjustment nut with a 14mm (9/16") socket head.
- b. Test lift tension by lifting head unit up and down. When desired lift tension has been achieved, replace cap.

b

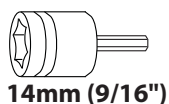

NOTE: Adjustment may require 40 - 60 revolutions.

c

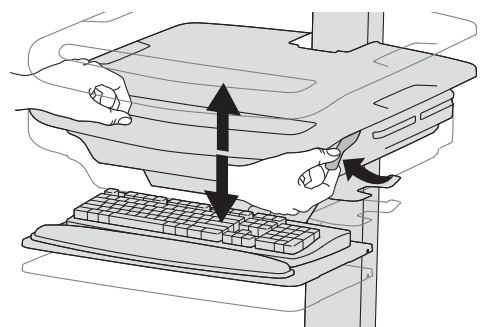

Option 3 - Mounting to wall track

- 1**
 - a. Attach the scanner shelf to the walltrack bracket using two 8/32x5/16" Phillips screws. Adjust the shelf to the desired height; ensure that the shelf is level, then tighten the screws.
 - b. Go to page 8 for options on how to secure scanner to shelf.



Note: several pair of mounting holes are available.

a 2x  8/32x5/16"

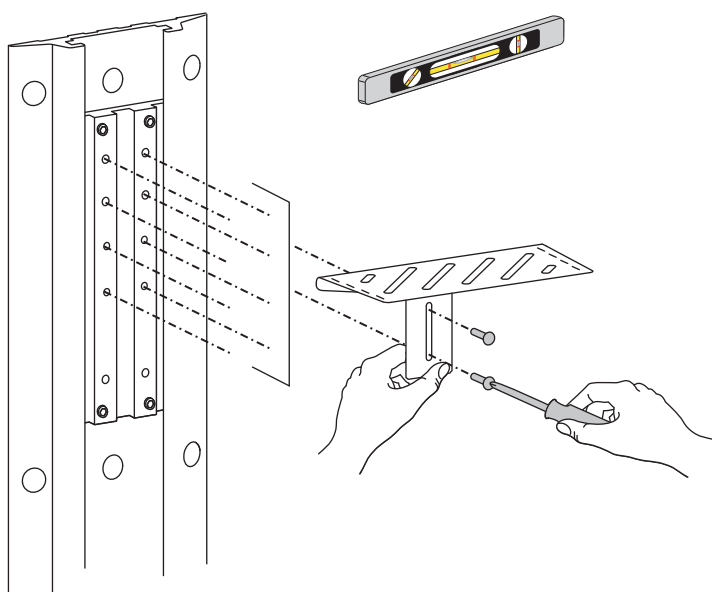

b

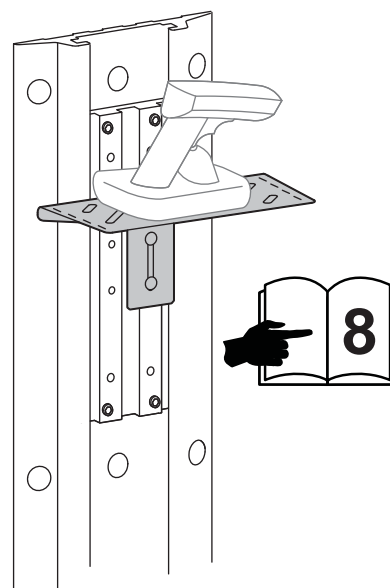

Option 4 - Mounting to rear of cart

1

a. Remove cap.

b. If present, remove existing accessory by sliding it up off the slot in the riser.



NOTE: loosen screws only, do not remove them.

c. Attach t-nut to scanner shelf with M5x12 screws as illustrated.

d. Slide shelf/nut assembly into slot, adjust shelf to the desired height and tighten the screws.

a

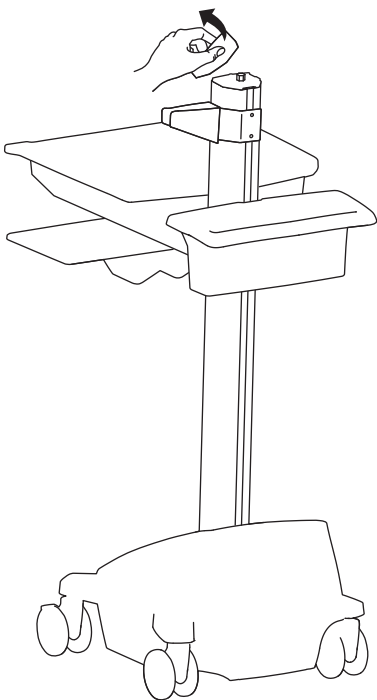

b

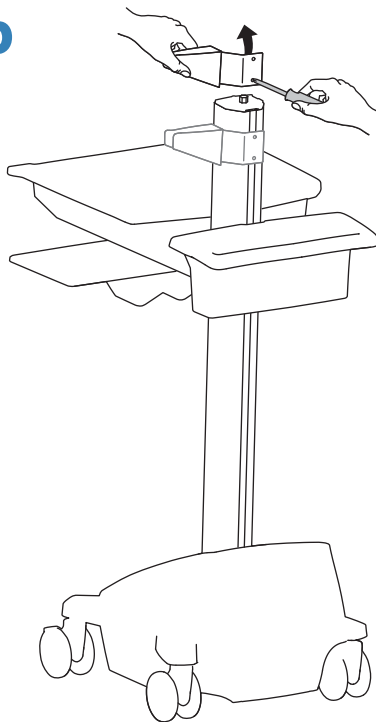

c

2x
M5 x 12mm

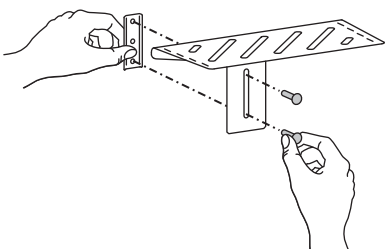

d

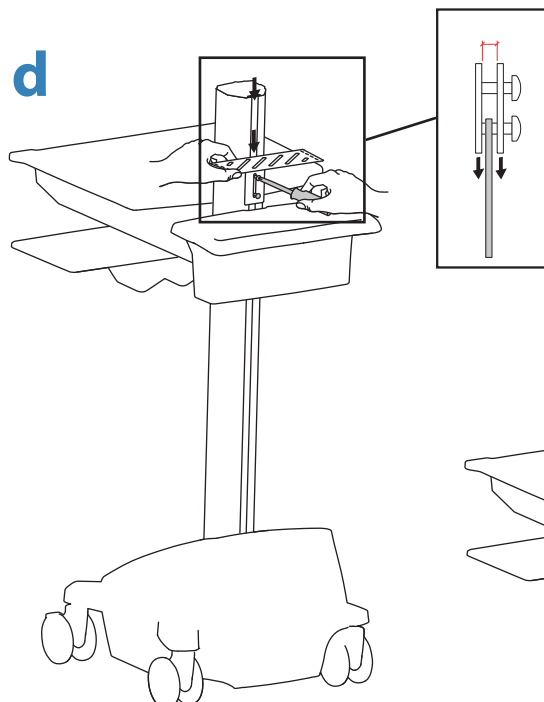

e

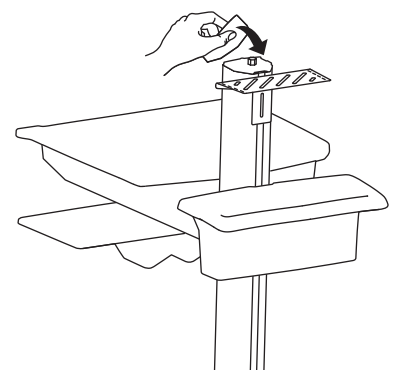

3 Mounting Options

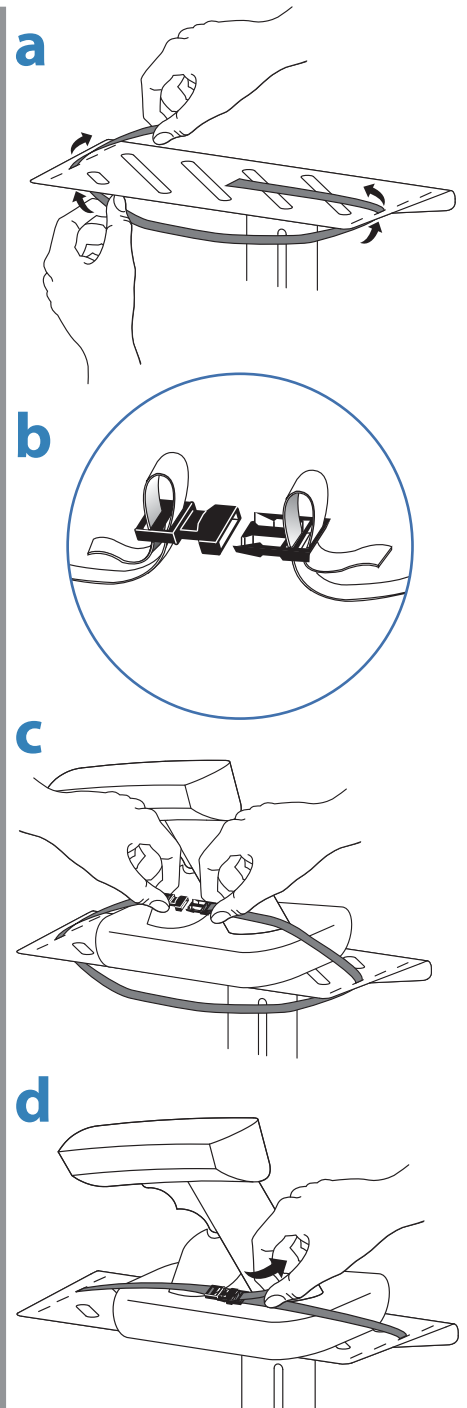
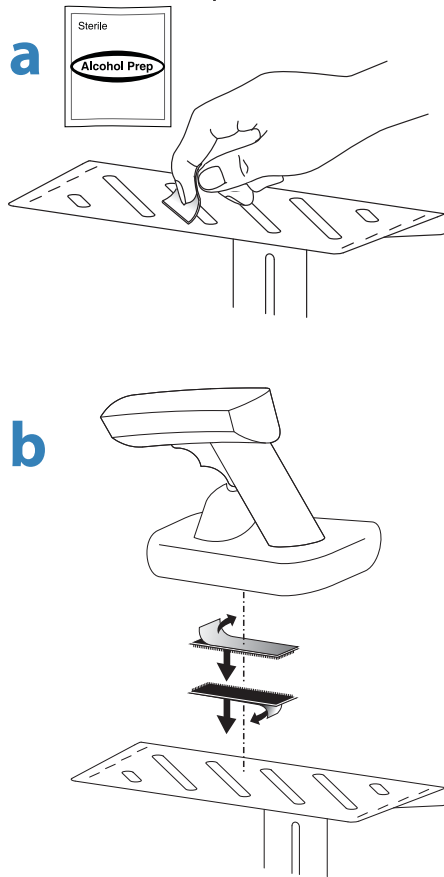
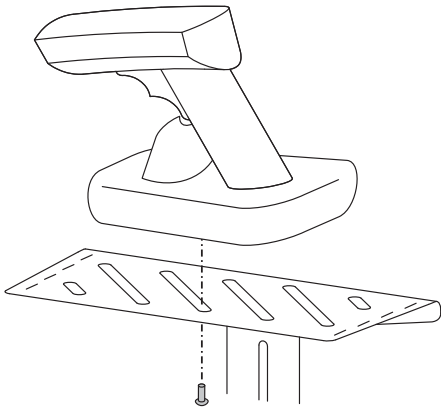

Touchboards

205 Westwood Ave, Long Branch, NJ 07740
 Phone: 866-94 BOARDS (26273) / (732)-222-1511
 Fax: (732)-222-7088 | E-mail: sales@touchboards.com

ERGOTRON®

While Ergotron, Inc. makes every effort to provide accurate and complete information on the installation and use of its products, it will not be held liable for any editorial errors or omissions (including those made in the process of translation from English to another language), or for incidental, special or consequential damages of any nature resulting from furnishing this instruction and performance of equipment in connection with this instruction. Ergotron, Inc. reserves the right to make changes in the product design and/or product documentation without notification to its users. For the most current product information, or to know if this document is available in languages other than those herein, please contact Ergotron. No part of this publication may be reproduced, stored in a retrieval system, or transmitted in any form or by any means, electronic, mechanical, photocopying, recording or otherwise without the prior written consent of Ergotron, Inc., 1181 Trapp Road, Eagan, Minnesota, 55121, USA. Patents Pending and Patented U.S. & Foreign. Ergotron is a registered trademark of Ergotron, Inc.

Americas Sales and Corporate Headquarters
 St. Paul, MN USA
 (800) 888-8458
 +1-651-681-7600
 www.ergotron.com
 sales@ergotron.com

EMEA Sales
 Amersfoort, The Netherlands
 +31 33 45 45 600
 www.ergotron.com
 info.eu@ergotron.com

APAC Sales
 Tokyo, Japan
 www.ergotron.com
 apaccustomerservice@ergotron.com

Worldwide OEM Sales
 www.ergotron.com
 info.oem@ergotron.com